

DEDICATION

KNOW ALL MEN (PERSONS) BY THESE PRESENT, THAT EVAN G. NIXON, THE UNDERSIGNED OWNERS, IN FEE SIMPLE OF THE LAND HEREBY PLATTED, HEREBY DECLARE THIS SHORT PLAT AND DEDICATE TO THE USE OF THE PUBLIC FOREVER ALL STREETS, AVENUES, PLACES AND SEWER EASEMENTS OR WHATEVER PUBLIC PROPERTY THERE IS SHOWN ON THIS SHORT PLAT, AND THE USE FOR ANY AND ALL PUBLIC PURPOSES NOT INCONSISTENT WITH THE USE THEREOF FOR PUBLIC HIGHWAY PURPOSES. ALSO, THE RIGHT TO MAKE ALL NECESSARY SLOPES FOR CUTS AND FILLS UPON LOTS, BLOCKS, TRACTS, ETC., SHOWN ON THIS SHORT PLAT IN THE REASONABLE ORIGINAL GRADING OF ALL THE STREETS, PLACES, ETC., SHOWN HEREON. ALSO, THE RIGHT TO DRAIN ALL STREETS OVER AND ACROSS ANY LOT OR LOTS WHERE WATER MIGHT TAKE A NATURAL COURSE AFTER THE STREET OF STREETS ARE GRADED. ALSO, ALL CLAIMS FOR DAMAGE AGAINST ANY GOVERNMENTAL AUTHORITY ARE WAIVED WHICH MAY BE OCCASIONED TO THE ADJACENT LAND BY THE ESTABLISHED, CONSTRUCTION, DRAINAGE, AND MAINTENANCE OF SAID ROADS.

FOLLOWING ORIGINAL REASONABLE GRADING OF ROADS AND WAYS HEREON, NO DRAINAGE WATERS ON ANY LOT OR LOTS SHALL BE DIVERTED OR BLOCKED FROM THEIR NATURAL COURSE SO AS TO DISCHARGE UPON ANY PUBLIC ROAD RIGHT-OF-WAYS TO HAMPER PROPER ROAD DRAINAGE. THE OWNER OF ANY LOT OR LOTS, PRIOR TO MAKING AN ALTERATION IN THE DRAINAGE SYSTEM AFTER THE RECORDING OF THE SHORT PLAT, MUST MAKE APPLICATION TO AND RECEIVE APPROVAL FROM THE DIRECTOR OF THE DEPARTMENT OF PUBLIC WORKS FOR SAID ALTERATION. ANY ENCLOSING OF DRAINAGE WATERS IN CULVERTS OR DRAINS OR REROUTING THEREOF ACROSS ANY LOT AS MAY BE UNDERTAKEN BY OR FOR THE OWNER OF ANY LOT SHALL BE DONE BY AND AT THE EXPENSE OF SUCH OWNER.

IN WITNESS WHEREOF, WE SET OUR HANDS AND SEALS THIS _____ DAY OF _____, 2024.

BY: _____

ACKNOWLEDGEMENTS

STATE OF WASHINGTON)
)SS
COUNTY OF SNOHOMISH)

I CERTIFY THAT I KNOW OR HAVE SATISFACTORY EVIDENCE THAT EVAN G. NIXON, A MANAGING MEMBER OF NIXON E&D, LLC, IS THE PERSON WHO APPEARED BEFORE ME, AND SAID PERSON ACKNOWLEDGED THAT HE SIGNED THIS INSTRUMENT AND ACKNOWLEDGED IT TO BE HIS FREE AND VOLUNTARY ACT FOR THE PURPOSES MENTIONED IN THIS INSTRUMENT.

DATED: _____

NOTARY PUBLIC IN AND FOR THE STATE OF WASHINGTON
RESIDING AT _____
MY APPOINTMENT EXPIRES: _____

AUDITOR'S CERTIFICATE

FILED FOR RECORD AT THE REQUEST OF GREAT WESTERN SURVEYING THIS _____ DAY OF _____ 2024, AT _____ MINUTES PAST _____ M, AND RECORDED IN VOLUME _____ OF PLATS, PAGES _____, RECORDS OF SNOHOMISH COUNTY, WASHINGTON.

AUDITOR, SNOHOMISH COUNTY

BY: _____
DEPUTY COUNTY AUDITOR

CITY OF MARYSVILLE APPROVALS

EXAMINED AND APPROVED THIS _____ DAY OF _____, 2024.

CITY ENGINEER, CITY OF MARYSVILLE

EXAMINED AND APPROVED THIS _____ DAY OF _____, 2024.

COMMUNITY DEVELOPMENT DIRECTOR, CITY OF MARYSVILLE

EXAMINED, FOUND TO BE IN COFORMITY WITH APPLICABLE ZONING AND OTHER LAND USE CONTROLS, AND APPROVED THIS _____ DAY OF _____, 2024.

MAYOR, CITY OF MARYSVILLE

ATTEST: CITY CLERK

EASEMENTS, COVENANTS AND RESRICTIONS

1. NO FURTHER SUBDIVISION OF ANY LOT WITHOUT RESUBMITTING FOR FORMAL PLAT OR REVISED SHORT PLAT CONSISTENT WITH TITLE 22 OF THE MARYSVILLE MUNICIPAL CODE.
2. THE SALE OR LEASE OF LESS THAN A WHOLE LOT IN ANY SUBDIVISION PLATTED AND FILED UNDER TITLE 22 OF THE MARYSVILLE MUNICIPAL CODE IS EXPRESSLY PROHIBITED EXCEPT IN COMPLIANCE WITH TITLE 22 OF THE MARYSVILLE MUNICIPAL CODE.
3. ALL LANDSCAPED AREAS IN PUBLIC RIGHT-OF-WAY SHALL BE MAINTAINED BY THE DEVELOPER AND THEIR SUCCESSOR(S) AND MAY BE REDUCED AND/OR ELIMINATED IF DEEMED NECESSARY IF DETRIMENTAL TO CITY ROAD PURPOSES.
4. THE LOCATION AND HEIGHT OF ALL FENCES AND OTHER OBSTRUCTIONS WITHIN AN EASEMENT AS DEDICATED ON THIS SHORT PLAT SHALL BE SUBJECT TO THE APPROVAL OF THE DIRECTOR OF PUBLIC WORKS OR HIS ASSIGNEE.
5. THE COST OF CONSTRUCTION AND MAINTAINING ALL ROADS NOT HEREIN DEDICATED AS PUBLIC ROADS SHALL BE THE OBLIGATION OF ALL THE OWNERS AND THE OBLIGATION TO MAINTAIN SHALL BE CONCURRENTLY THE OBLIGATION OF ANY CORPORATION IN WHICH TITLE TO THE ROADS AND STREETS MAY BE HELD. IN THE EVENT THAT THE OWNERS OF ANY LOT SERVED BY THE ROADS OR STREETS OF THIS SHORT PLAT SHALL PETITION TO THE COUNCIL TO INCLUDE THESE ROADS AND STREETS TO THE PUBLIC ROAD SYSTEM, THE PETITIONERS SHALL BE OBLIGATED TO BRING THE SAME TO CITY ROAD STANDARDS APPLICABLE AT THE TIME OF PETITION IN ALL RESPECTS, INCLUDING DEDICATION OF ALL RIGHTS-OF-WAY, PRIOR TO ACCEPTANCE FROM THE CITY.
6. THE APPLICANT SHALL SUBMIT PAYMENT TO MARYSVILLE SCHOOL DISTRICT NO. 25 FOR SCHOOL IMPACTS CAUSED BY THE DEVELOPMENT IN ACCORDANCE WITH MMC CHAPTER 22D.040, SCHOOL IMPACT FEES AND MITIGATION. SCHOOL MITIGATION FEE SCHEDULES IN EFFECT AT THE TIME AND INDIVIDUAL PERMIT APPLICATION IS ACCEPTED BY THE CITY. SAID IMPACT FEES HAVE BEEN DEFERRED, AND SHALL BE PAID PRIOR TO FINAL BUILDING INSPECTIONS BEING GRANTED FOR THE INDIVIDUAL SINGLE FAMILY RESIDENCES OR LOT.
7. THE APPLICANT SHALL SUBMIT PAYMENT TO THE CITY OF MARYSVILLE FOR PARK IMPACTS CAUSED BY THE DEVELOPMENT IN ACCORDANCE WITH MMC CHAPTER 22D.020, PARKS, RECREATION, OPEN SPACE AND TRAIL IMPACT FEES AND MITIGATION. PARK MITIGATION FEES WILL BE BASED ON THE FEE SCHEDULES IN EFFECT AT THE TIME AN INDIVIDUAL BUILDING PERMIT APPLICATION IS ACCEPTED BY THE CITY, AND WILL BE REQUIRED TO BE PAID PRIOR TO BUILDING PERMIT ISSUANCE UNLESS DEFERRED UNTIL A TIME PRECEDING FINAL BUILDING INSPECTIONS BEING GRANTED.
8. IN ORDER TO MITIGATE IMPACTS UPON THE FUTURE CAPACITY OF THE ROAD SYSTEM, THE APPLICANT SHALL BE REQUIRED TO SUBMIT PAYMENT TO THE CITY OF MARYSVILLE, ON A PROPORTIONATE SHARE COST OF THE FUTURE CAPACITY IMPROVEMENTS AS SET FORTH IN MMC 22D.030.070(3), FOR THE DEVELOPMENT. TRAFFIC IMPACT FEES SHALL BE VESTED AT A RATE OF \$6,300.00 OR AS CURRENTLY RECOGNIZED, PER NEW SINGLE FAMILY RESIDENCE. SAID IMPACT FEES HAVE BEEN DEFERRED, AND SHALL BE PAID PRIOR TO FINAL BUILDING INSPECTIONS BEING GRANTED FOR THE INDIVIDUAL SINGLE FAMILY RESIDENCES OR LOT.

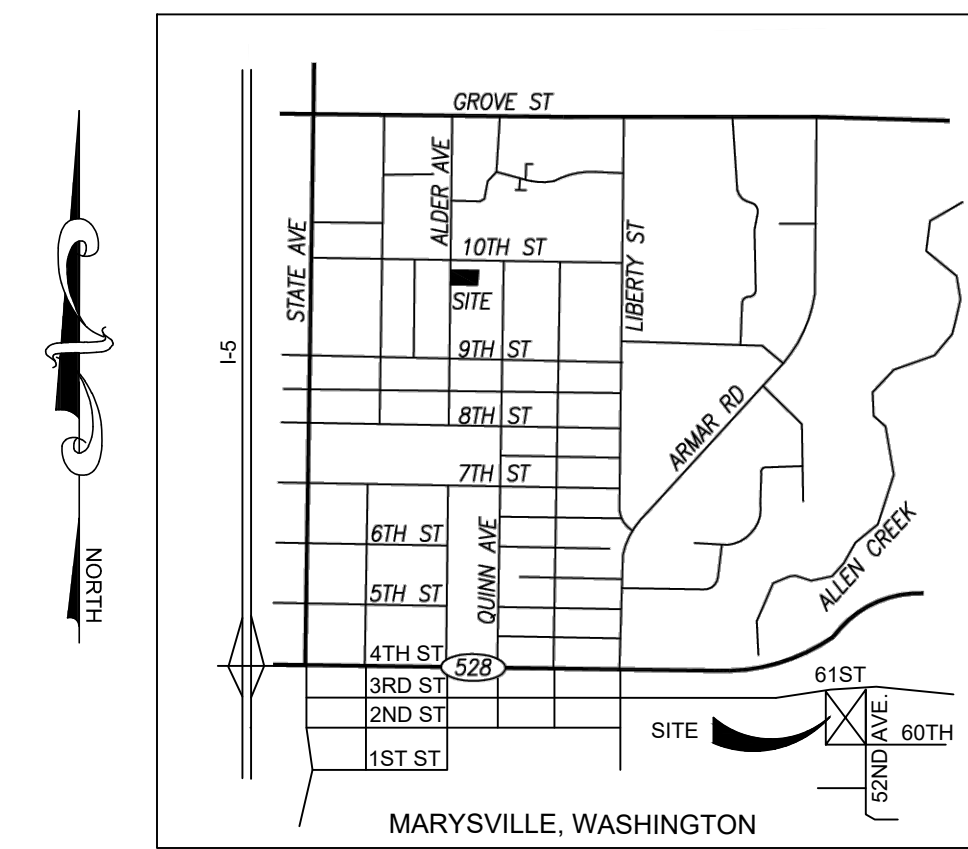

VICINITY MAP
NOT TO SCALE

SURVEY NOTES

FIELD MEASUREMENTS USED TO PREPARE THIS SURVEY WERE MADE IN MAY 2022.

BASIS OF BEARING: MONUMENTED CENTERLINE 52nd AVENUE

BEARING: N02°16'46"W (PER PLAT OF EBEE LANDING-AUDITORS FILE NO. 200002255002)

BASIS OF ELEVATION: CITY OF MARYSVILLE SEWER RIM SS MH #2
SANITARY SEWER PLAN EBEE LANDING BY BELMARK INDUSTRIES DATED 01.07.00

ELEVATION: 28.66 (NGVD 29 DATUM)

ALL EASEMENTS SHOWN ON THIS SURVEY ARE PROVIDED, PER RECORD. THERE IS NO GUARANTEE TO UNRECORDED EASEMENTS OR THOSE EASEMENTS NOT SHOWN PER RECORD.

ALL LINES OF OCCUPATION HAVE BEEN NOTED ON THIS SURVEY. NO ATTEMPT HAS BEEN MADE TO RESOLVE THESE LINES OF OCCUPATION, IF ANY.

UTILITIES ARE SHOWN PER VISUAL OBSERVANCE.
(VERIFY ALL UTILITIES BEFORE DESIGN AND CONSTRUCTION)

LEGAL DESCRIPTION (AUDITOR FILE NO. 8811230026)

LOTS 15 AND 16, BLOCK 2 AND ALL THAT PORTION OF LOTS 1 AND 2, BLOCK 2 LYING SOUTH OF PACIFIC HIGHWAY, TOGETHER WITH THAT PORTION OF VACATED ALLEY LYING BETWEEN LOTS 1 AND 2 AND 15 AND 16, BLOCK 2, BAY VIEW ADDITION TO MARYSVILLE, ACCORDING TO PLAT THEREOF RECORDED IN VOLUME 2 OF PLATS, PAGE 52 RECORD OF SNOHOMISH COUNTY, WASHINGTON.

TOGETHER WITH THE NORTH HALF OF VACATED JUDSON STREET ON THE SOUTH THAT WOULD ATTACH BY OPERATION OF LAW.

SURVEY REFERENCES

- PLAT OF BAY VIEW ADDITION TO MARYSVILLE (AF NO. 189007305001)
- PLAT OF EBEE LANDING (AF NO. 200002255002)
- PLAT OF ANDREWS VISTA (AF NO. 9407155007)

SURVEYOR'S CERTIFICATION

I HEREBY CERTIFY THAT THIS MAP AND THE SURVEY ON WHICH IT IS BASED WAS PREPARED UNDER MY DIRECT SUPERVISION AND IS, TO THE BEST OF MY KNOWLEDGE, AN ACCURATE REPRESENTATION THEREOF.

DATE: _____

URBAN P. VISSER LS 34146

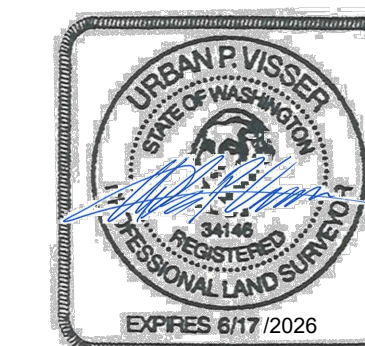

Great Western Surveying

Urban P. Visser, RLS
2543 South Shady Knoll
Flagstaff, Arizona 86001
(928) 225-9113
urbanvisser@gmail.com

HARBOR VIEW HEIGHTS
SHORT PLAT
NUMBER SP23-007

PORTION OF BAY VIEW ADDITION TO MARYSVILLE
SOUTHWEST QUARTER OF SECTION 27, T30N, R9E, W.M.
CITY OF MARYSVILLE, SNOHOMISH COUNTY, WASHINGTON

DATE:
10/15/2024

PROJECT NUMBER:
2022102

DRAWN BY:
CJI

SHEET:
1 OF 2

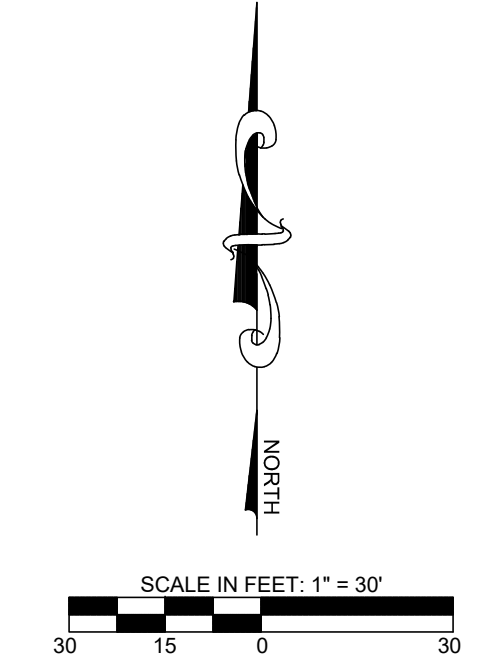
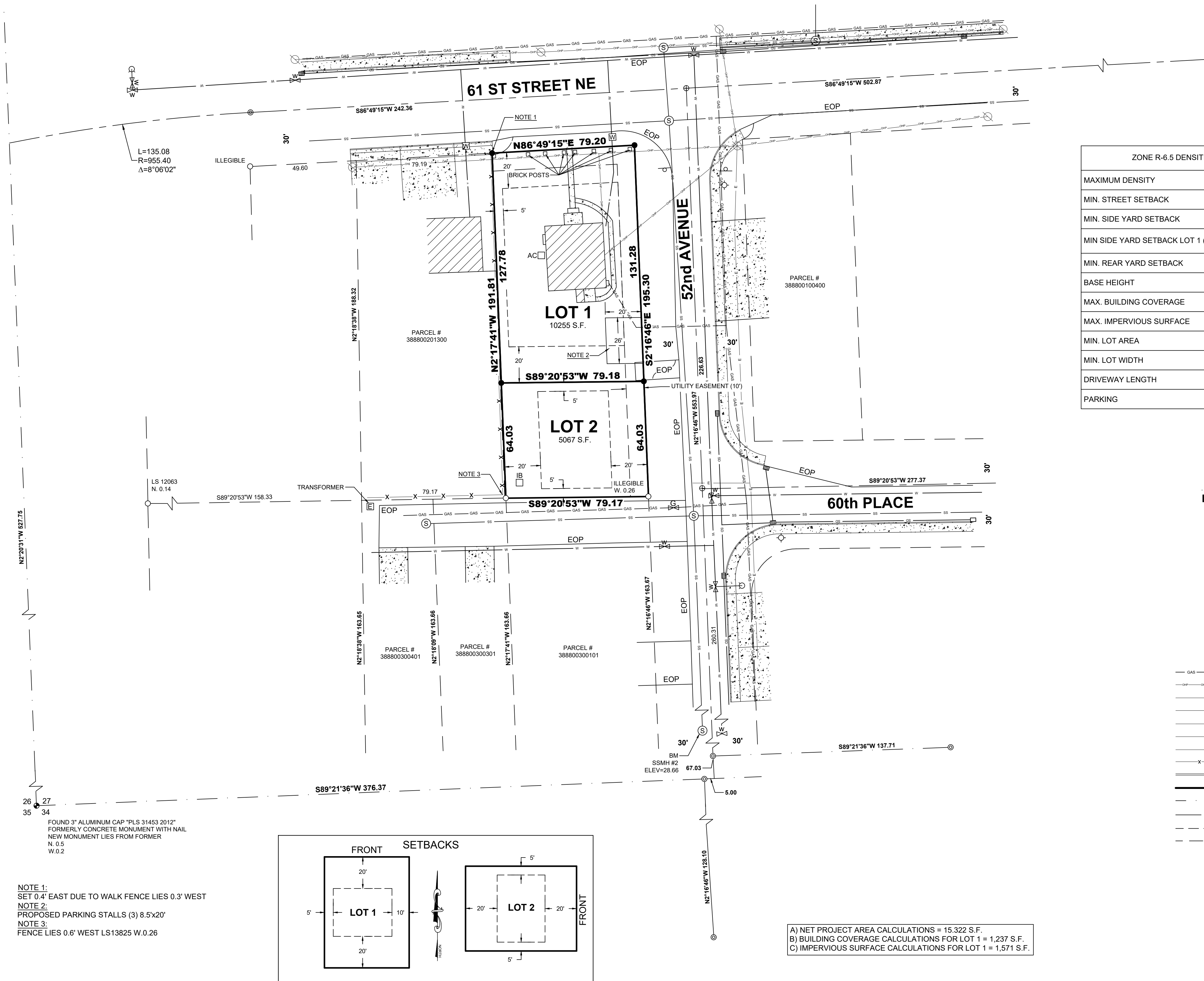

ZONE R-6.5 DENSITIES AND DIMENSION STANDARDS (MMC 22C.010.080)	
MAXIMUM DENSITY	6.5 DU/ACRE
MIN. STREET SETBACK	20 FEET
MIN. SIDE YARD SETBACK	5 FEET
MIN SIDE YARD SETBACK LOT 1 (52ND)	10 FEET
MIN. REAR YARD SETBACK	20 FEET
BASE HEIGHT	30 FEET
MAX. BUILDING COVERAGE	40 %
MAX. IMPERVIOUS SURFACE	50%
MIN. LOT AREA	5,000 S.F.
MIN. LOT WIDTH	50 FEET
DRIVEWAY LENGTH	20 FEET
PARKING	3 STALLS PER SINGLE FAMILY DWELLING

LEGEND

- AC □ AC - AIR CONDITIONER
- ⊙ EXISTING SEWER MANHOLE
- ⊞ EXISTING CATCH BASIN
- ⊞ EXISTING WATER METER
- ⊞ EXISTING WATER VALVE
- ⊞ EXISTING FIRE HYDRANT
- ⊞ IB - IRRIGATION BOX
- ⊞ EXISTING GAS VALVE
- ⊞ EXISTING POWER POLE
- ⊞ EXISTING LIGHT POLE
- ⊞ EXISTING ELECTRIC BOX
- ⊞ EXISTING SIGN
- GAS — EXISTING GAS LINE
- OP — EXISTING OVERHEAD POWER
- T — OVERHEAD TELEPHONE
- E — EXISTING ELECTRIC UNDERGROUND
- SS — EXISTING SEWER LINE
- W — EXISTING WATER LINE
- SD — EXISTING STORM DRAIN
- X — EXISTING BOARD FENCELINE
- C — EXISTING CURB AND GUTTER
- B — BOUNDARY LINE
- S — SECTION LINE
- CL — CENTERLINE
- SL — SETBACK LINE
- - - UTILITY EASEMENT (10')
- FOUND ALUMINUM CAP
- FOUND 1/2" BRASS CAP IN CASE "LS 30427"
- FOUND 3/8" REBAR WITH CAP AS NOTED
- SET 3/8" REBAR WITH CAP LS 34146
- ⊞ CALCULATED LOCATION
- ▨ EXISTING CONCRETE
- ▨ EXISTING BUILDING
- EOP — EDGE OF PAVEMENT

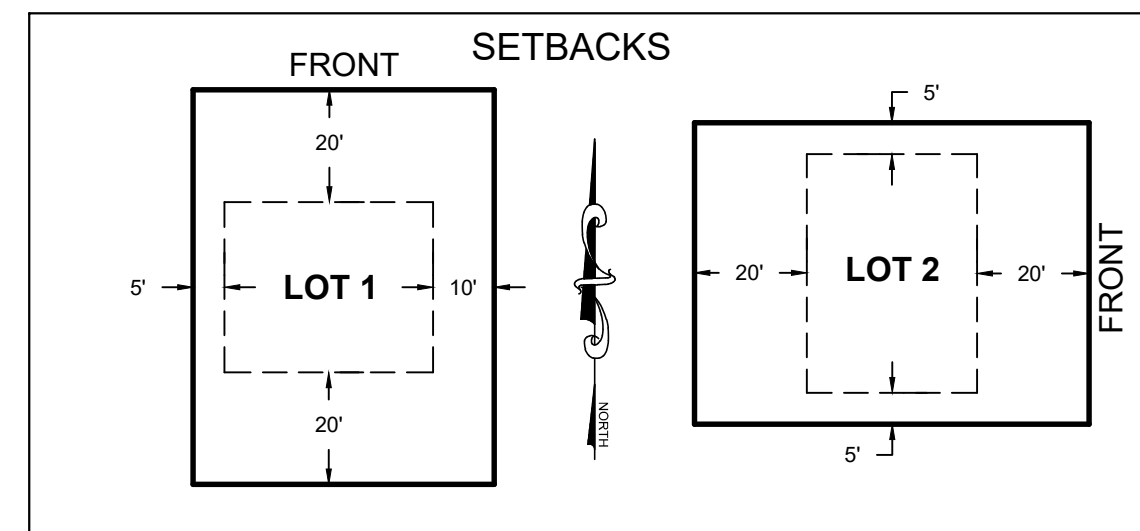

A) NET PROJECT AREA CALCULATIONS = 15,322 S.F.
 B) BUILDING COVERAGE CALCULATIONS FOR LOT 1 = 1,237 S.F.
 C) IMPERVIOUS SURFACE CALCULATIONS FOR LOT 1 = 1,571 S.F.

NOTE 1:
SET 0.4' EAST DUE TO WALK FENCE LIES 0.3' WEST
 NOTE 2:
PROPOSED PARKING STALLS (3) 8.5'x20'
 NOTE 3:
FENCE LIES 0.6' WEST LS13825 W.0.26

Great Western Surveying
 Urban P. Visser, RLS
 2543 South Shady Knoll
 Flagstaff, Arizona 86001
 (928) 225-9113
 urbanvisser@gmail.com

**HARBOR VIEW HEIGHTS
 SHORT PLAT
 NUMBER SP23-007**

PORTION OF BAY VIEW ADDITION TO MARYSVILLE
 SOUTHWEST QUARTER OF SECTION 27, T30N, R9E, W.M.
 CITY OF MARYSVILLE, SNOHOMISH COUNTY, WASHINGTON

DATE:
10/15/2024

PROJECT NUMBER:
2022102

DRAWN BY:
CJI

SHEET:
2 OF 2

