

GEOTECHNICAL REPORT

**Marysville 172 and 23 Apartments
172nd Street Northeast and 19th Avenue Northeast
Marysville, Washington**

Project No. T-8541

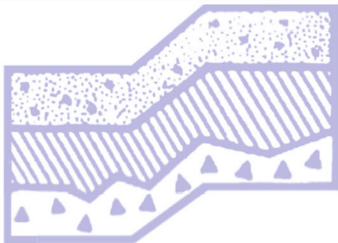

Terra Associates, Inc.

Prepared for:

**Marysville 172nd Development, LLC
Seattle, Washington**

March 9, 2022



TERRA ASSOCIATES, Inc.

Consultants in Geotechnical Engineering, Geology
and
Environmental Earth Sciences

March 9, 2022
Project No. T-8541

Ms. Lis Soldano
Marysville 172nd Development, LLC
411 – 1st Avenue South, Suite 650
Seattle, Washington 98104

Subject: Geotechnical Report
Marysville 172 and 23 Apartments
172nd Street Northeast and 19th Avenue Northeast
Marysville, Washington

Dear Ms. Soldano:

As requested, we have conducted a geotechnical engineering study for the subject project. The attached report presents our findings and recommendations for the geotechnical aspects of project design and construction.

The site soils consist of native recessional outwash deposits comprised of loose to medium dense, sand, silty sand, sandy silt, and soft to medium stiff clayey silt to silty clay. Approximately 8 to 11 feet of medium dense silty sand with gravel fill overlies the native soils in the eastern parcel of the site. Groundwater levels measured in slotted PVC standpipes installed in several of the test pits ranged from the ground surface to a depth of about three feet.

Soil conditions observed at the site will be suitable for support of the development as planned, provided the recommendations contained herein are incorporated into design and construction. Preloading the site with the fill used to raise site grades by a minimum of four feet will mitigate post-construction settlements of the compressible native soils. Detailed recommendations for preloading the site along with other geotechnical design considerations are included in the attached report.

We trust the information provided in the attached report is sufficient for your current needs. If you have any questions or need additional information, please call.

Sincerely yours,
TERRA ASSOCIATES, INC.

John C. Sadler, L.E.G., L.H.G.
Senior Engineering Geologist

Carolyn S. Decker, P.E.
President

3-9-2022

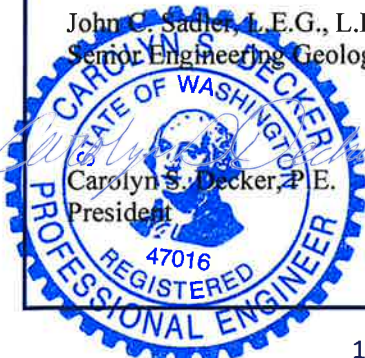

TABLE OF CONTENTS

	<u>Page No.</u>
1.0 Project Description	1
2.0 Scope of Work	1
3.0 Site Conditions	2
3.1 Surface	2
3.2 Soils	2
3.3 Groundwater	3
3.4 Geologic Hazards	4
3.5 Seismic Site Class.....	5
4.0 Discussion and Recommendations	6
4.1 General.....	6
4.2 Site Preparation and Grading.....	6
4.3 Excavations.....	8
4.4 Foundations	9
4.5 Slab-on-Grade Floors.....	9
4.6 Lateral Earth Pressures for Wall Design.....	10
4.7 Infiltration Feasibility	10
4.8 Stormwater Detention Facilities	10
4.9 Drainage.....	11
4.10 Utilities	12
4.11 Pavements.....	12
5.0 Additional Services.....	13
6.0 Limitations.....	13

Figures

Vicinity Map.....	Figure 1
Exploration Location Plan	Figure 2
Typical Settlement Marker Detail.....	Figure 3
Typical Wall Drainage Detail	Figure 4

Appendix

Field Exploration and Laboratory Testing	Appendix A
--	------------

Geotechnical Report Marysville 172 and 23 Apartments 172nd Street Northeast and 19th Avenue Northeast Marysville, Washington

1.0 PROJECT DESCRIPTION

The proposed project is a residential development. A conceptual site plan by Milbrandt Architects, dated February 17, 2022, shows the development consisting of fifteen 3-story, wood-framed, garden-style buildings, an approximately 5,000 square foot (sf) community building, and associated accessory/amenity structures. Foundation loads should be relatively light, in the range of 2 to 3 kips per foot for bearing walls and 20 to 40 kips for isolated columns. We understand that the current conceptual site development includes raising site grades to generally match those in the eastern portion of the site where about eight to ten feet of fill has recently been placed.

The recommendations contained in the following sections of this report are based on our understanding of the above design features. We should review design drawings as they become available to verify our recommendations have been properly interpreted and incorporated into project design and to amend or supplement our recommendations, if required.

2.0 SCOPE OF WORK

We explored subsurface conditions at the site in 24 test pits excavated to maximum depths ranging between about 6 and 12 feet using a track-mounted excavator. Our characterization of subsurface conditions also included information presented on the logs of two test pits and one 50-foot cone penetration test (CPT), that were conducted in the eastern portion of the site as part of previous geotechnical work by Terra Associates, Inc. in 2006 and 2007. Based on the results of our fieldwork, laboratory testing, and analyses, we developed geotechnical recommendations for project design and construction. Specifically, this report addresses the following:

- Soil and groundwater conditions.
- Geologic Hazards per the City of Marysville Municipal Code.
- Seismic site class per the current International Building Code (IBC).
- Site preparation and grading.
- Excavations.
- Foundations.
- Floor slabs.
- Lateral earth pressures for wall design.
- Stormwater facilities.
- Infiltration feasibility.
- Drainage.
- Utilities.
- Pavements.

It should be noted, recommendations outlined in this report regarding drainage are associated with soil strength, design earth pressures, erosion, and stability. Design and performance issues with respect to moisture as it relates to the structure environment are beyond Terra's purview. A building envelope specialist or contractor should be consulted to address these issues, as needed.

3.0 SITE CONDITIONS

3.1 Surface

The project site is an 18.53-acre assemblage of seven parcels located southeast of and adjacent to the intersection of 172nd Street Northeast and 19th Avenue Northeast in Marysville, Washington. The approximate site location is shown on Figure 1.

Four single-family residences and scattered outbuildings occupy the northern portion of the six western-most parcels of the site. Site areas located south of the existing structures are generally undeveloped fields or lawn. The eastern 4.42-acre parcel is undeveloped and currently being graded with fill. Site vegetation consists mainly of field grasses, grass lawn, or brush with scattered mature deciduous, coniferous and landscape trees and shrubs. Where present, vegetation in the eastern parcel consists mainly of sparse grasses.

Site topography is relatively flat. The Snohomish County Planning & Development Services (PDS) Map Portal (<https://gismaps.snoco.org/Html5Viewer/Index.html?viewer=pdsmappointal>) shows natural surface elevations ranging from about Elev. 114 in the western portion of the site to about Elev. 118 in the eastern portion. As discussed, grades in the eastern-most parcel have recently been raised about eight to ten feet above this elevation. Review of historical aerial photographs available on Google Earth indicates that grading on the eastern parcel began after July 2018.

We observed several localized areas of surface water accumulation within the western parcel of the site, in shallow ditches dug along the southern and western site margins, and along the eastern and western parcel margins in the site interior. The water observed in the ditches was generally about two feet below adjacent surface grade and did not appear to be flowing.

3.2 Soils

The soils observed in the test pits generally consist of several feet of medium dense, moist to wet, fine- to medium-grained sand with varying proportions of silt and gravel overlying loose to medium dense, moist to wet, massive to laminated, low-plasticity silt to fine sandy silt or very soft to soft, wet, clayey silt to silty clay. The silt and clay deposits were encountered below depths ranging from about 14 inches at Test Pit TP-4 to about seven feet at TP-11.

Test Pits TP-13 through TP-24 were excavated in the eastern parcel of the site where extensive grading has occurred. All of these test pits encountered fill consisting primarily of medium dense, moist, silty sand with gravel with trace to scattered amounts of concrete, wood, or plastic debris. The observed fill thicknesses range from about 6.5 feet at Test Pit TP-16 to about 11 feet at TP-22. Native soils observed beneath the fill consist of medium dense, moist, sand with gravel and sandy silt, or stiff, moist, organic silt. Two test pits excavated by Terra Associates, Inc. on the eastern-most parcel in December 2006 encountered loose to medium dense, moist to wet, fine- to medium-grained sand to the test pit termination depths of about 6.5 and 7.5 feet.

As discussed, an approximately 50-foot deep CPT was performed for Terra in the eastern-most parcel of the site in 2007. The CPT data shows interbedded outwash deposits extending the full 50-foot depth of the CPT. Soil behavior types determined from the CPT data generally consist of about eight feet of sand and silty sand to sandy silt underlain primarily by sandy silt to silty clay with scattered sand to silty sand layers. In general, where cohesive silt and clay soils are indicated, correlated N_{60} values indicate consistencies in the soft to medium stiff range. Where cohesionless sand, silty sand, and silt soils are indicated, correlated N_{60} values indicate relative densities typically in the loose to medium dense range.

The *Geologic map of the Arlington West 7.5 minute quadrangle, Snohomish County, Washington* by J.P. Minard (1985) shows surface geology at the site mapped as the Marysville Sand Member (Qvrm) and the Clay Member (Qvrc) of Vashon recessional outwash deposits in the eastern and western portions of the site, respectively. The native soils observed in the subsurface explorations are generally consistent with these geologic map units.

The preceding discussion is intended to be a general review of the soil conditions encountered in the subsurface explorations. For more detailed descriptions, please refer to the Test Pit Logs in Appendix A. The CPT data plot is also attached in Appendix A. The approximate test pit and CPT locations are shown on Figure 2.

3.3 Groundwater

Groundwater seepage was observed in Test Pits TP-1 through TP-12 and in both of the test pits excavated on the eastern parcel in December 2006. The observed seepage rates varied from light to heavy and typically occurred within sand deposits below depths of about three to four feet.

The groundwater levels indicated by seepage in the test pits may not accurately reflect the actual depth of groundwater beneath the site, as most of the test pits were not allowed to remain open for more than a few minutes due to caving. As indicated on the following table, subsequent groundwater levels measured in two-inch diameter perforated PVC standpipes installed in Test Pits TP-2, TP-3, TP-10, and TP-12 were all higher than those indicated by seepage observations during test pit excavation a week or more prior.

Approximate Depth to Groundwater (feet below ground surface)					
Date	Method	TP-2	TP-3	TP-10	TP-12
12/20/21	1	4.00	3.00	4.00	5.00
12/28/21	2	0.00	0.10	2.80	2.90
1/4/22	2	0.00	0.00	2.20	2.10
1/11/22	2	0.00	0.00	2.50	2.60
1/19/22	2	0.20	0.20	2.70	2.80
1/27/22	2	0.40	0.60	2.60	3.10
2/2/22	2	0.30	0.40	2.50	3.10
2/8/22	2	0.50	0.80	2.90	3.20
2/15/22	2	0.80	1.10	2.90	3.30
2/22/22	2	0.30	0.30	2.80	3.00
3/2/22	2	0.10	0.20	2.60	2.80

Method 1. Groundwater seepage level observed in test pit

Method 2. Groundwater level measured in slotted PVC standpipe

Considering that the groundwater observations were made between late December and early March, we expect that the observed groundwater levels and seepage flow rates are near seasonal high conditions. We expect these conditions will fluctuate on a seasonal basis with diminished levels occurring during the drier summer and early fall months.

3.4 Geologic Hazards

We evaluated site conditions for the presence of geologic hazards as designated in the Marysville Municipal Code (MMC). Chapter 22A.020.080 (G Definitions) of the MMC defines geologic hazard areas (GHAs) as lands or areas characterized by geologic, hydrologic, and topographic conditions that render them susceptible to potentially significant or severe risk of landslides, erosion, or seismic activity.

3.4.1 Erosion Hazard Areas

Chapter 22A.020.060 (E Definitions) of the MMC defines erosion hazard areas as “lands or areas that, based on a combination of slope inclination and the characteristics of the underlying soils, are susceptible to varying degrees of risk of erosion.” Erosion hazard areas are classified as low hazard, moderate hazard, and high hazard, based on the following criteria:

1. Low Hazard. Areas sloping less than 15 percent.
2. Moderate Hazard. Areas sloping between 15 and 40 percent and underlain by soils that consist predominantly of silt, clay, bedrock, or glacial till.
3. High Hazard. Areas sloping between 15 and 40 percent that are underlain by soils consisting largely of sand and gravel, and all areas sloping more steeply than 40 percent.”

Using the above criteria, and considering that the site is relatively flat with the exception of shallow ditch sideslopes and localized fill slopes in the site interior, it is our opinion that the subject site has a low erosion hazard. The site soils will, however, be susceptible to erosion and disturbance when exposed during construction. In our opinion, the erosion potential of site soils would be adequately mitigated with proper implementation and maintenance of Best Management Practices (BMPs) for erosion prevention and sedimentation control during construction. All erosion and sedimentation control BMPs should conform with City of Marysville requirements.

3.4.2 Landslide Hazard Areas

Chapter 22A.020.130 (L Definitions) of the MMC defines landslide hazard areas as “areas that, due to a combination of slope inclination and relative soil permeability, are susceptible to varying degrees of risk of land sliding.” Landslide hazard areas are classified as Classes I- IV based on the degree of risk as follows:

1. Low Hazard. Areas with slopes of less than 15 percent.
2. Moderate Hazard. Areas with slopes of between 15 and 40 percent and that are underlain by soils that consist largely of sand, gravel, bedrock, or glacial till.
3. High Hazard. Areas with slopes between 15 percent and 40 percent that are underlain by soils consisting largely of silt and clay, and all areas sloping more steeply than 40 percent.
4. Very High Hazard. Areas with slopes over 40 percent and areas of known mappable landslide deposits.”

Based on the above criteria, and considering the relatively flat site topography, the site is classified as a low landslide hazard area. In our opinion, site the conditions are not susceptible to landsliding and no hazard mitigation is required.

3.4.3 Seismic Hazard Areas

Chapter 22A.020.200 (S Definitions) of the MMC defines seismic hazard areas as “areas that, due to a combination of soil and groundwater conditions, are subject to severe risk of ground shaking, subsidence, or liquefaction of soils during earthquakes. These areas are typically underlain by soft or loose saturated soils (such as alluvium), have a shallow groundwater table and are typically located on the floors of river valleys. Seismic hazard areas are classified as follows:

1. Low Hazard. Areas underlain by dense soils or bedrock.
2. High Hazard. Areas underlain by soft or loose saturated soils.”

Based on soil and groundwater conditions observed in our subsurface explorations and the above criteria, the seismic hazard of the site is classified as “high hazard.” Based the shallow groundwater levels at the site and the soil behavior types determined from the CPT data, it is our opinion that soil liquefaction could occur in the sand deposits observed in the upper approximately ten feet of soil during a severe seismic event with expected total settlements between about two and four inches, half of which could be differential. If unmitigated, these settlements could result in some building distress, but in our opinion, would not structurally impair the building’s use.

As discussed, it is our understanding that the planned development will include raising site grades with several feet of structural fill. In our opinion, raising site grades with at least four feet of structural fill above natural surface grades would adequately mitigate the potential for damaging settlement resulting from seismically-induced soil liquefaction.

3.5 Seismic Site Class

As discussed in the previous section, soil conditions at the site will be subject to the soil liquefaction phenomenon during a severe seismic event. Because of this condition, per the current International Building Code (IBC), subsurface conditions would be assigned site class “F” which would require performing a site-specific seismic analysis to determine seismic forces for structural design. However, the IBC allows for using code derived seismic values for the soil conditions indicated if the building’s fundamental period is equal to or less than 0.5 seconds. If the proposed building falls into this category, based on soil conditions encountered and our knowledge of the area geology, site class “E” can be used to determine seismic design forces.

4.0 DISCUSSION AND RECOMMENDATIONS

4.1 General

Based on our study, in our opinion, there are no geotechnical constraints that would preclude development as currently planned. The primary geotechnical issues are the presence of fine-grained native soils that will consolidate under static loading imposed by the structures, shallow groundwater levels, and the potential for liquefaction-induced settlement resulting from a severe seismic event. In our opinion, raising site grades with at least four feet of structural fill and allowing settlements to occur under this load before initiating construction would adequately mitigate post-construction settlement under static loading and the potential for unacceptable liquefaction-induced settlement. We expect that settlements associated with the preloading would occur in about four to six weeks following full application of the structural fill pad.

The structures can be supported by conventional spread footing foundations bearing on a minimum structural fill thickness of two feet. Floor slabs and pavements can be similarly supported. The existing fill observed in the eastern site parcel consists of medium dense, moist mineral soil with debris inclusions. In our opinion, the existing fill would generally be suitable for support of the planned residential structures. However, due to the potential for inconsistencies in the relative density of the existing fill materials, foundation subgrades should be mechanically compacted in place to provide a uniform subgrade condition.

With the assumption that site grades will be raised by at least four feet, it remains possible that deeper utility excavations and excavations required for onsite stormwater management facilities could extend below the groundwater table. Any excavations extending below the groundwater table will likely require dewatering to maintain relatively dry working conditions and increase the stability of the granular soils. Design and construction of deeper utility structures that may be impacted by groundwater will need to include buoyancy effects and hydrostatic pressures acting on the structure.

Some of the near-surface soils contain a sufficient amount of fines (silt- and clay-sized particles) that will make them difficult to compact as structural fill when too wet. Accordingly, the ability to use the soils from site excavations as structural fill will depend on their moisture content and the prevailing weather conditions at the time of construction. If grading activities will take place during the winter season, the owner should be prepared to import free-draining granular material for use as structural fill and backfill.

Detailed recommendations regarding these issues and other geotechnical design considerations are provided in the following sections of this report. These recommendations should be incorporated into the final design drawings and construction specifications.

4.2 Site Preparation and Grading

In general, it will not be necessary to strip the organic surface layer where structural fill thicknesses above existing grade are a minimum of four feet. However, existing surface vegetation should be mowed close to the ground with the cut debris removed from the site. Alternatively, the grass can be tilled or farmed into the surface soils. Clearing of trees should include removal of the entire tree root ball.

We recommend removing existing building foundations and slabs and abandoning underground septic systems and other buried utilities from the planned development area. Abandoned utility pipes that fall outside of new building areas can be left in place provided they are sealed to prevent intrusion of groundwater seepage and soil.

Once clearing and stripping operations are complete, fill operations can be initiated to establish desired grades. Prior to placing fill, all exposed surfaces should be compacted using a large, heavy, vibratory roller to densify the loose upper soils and determine if any isolated soft and yielding areas are present. We recommend that a Terra Associates, Inc. representative be onsite to observe proofrolling and verify suitable subgrade conditions. If excessively yielding areas are observed and cannot be stabilized in place by compaction, the affected soils should be excavated and removed to firm bearing soil and grade restored with new structural fill. If the depth of excavation to remove unstable soils is excessive, use of a geotextile reinforcing/separation fabric such as Mirafi 500X or equivalent can be considered in conjunction with structural fill. Our experience has shown, in general, a minimum of 18 inches of a clean, granular structural fill over the geotextile fabric should establish a stable bearing surface.

Our study indicates that most of the near-surface native soils and existing fill soils contain a sufficient percentage of fines (silt and clay size particles) that will make them difficult to compact as structural fill if they are too wet or too dry. Accordingly, the ability to use these native soils from site excavations as structural fill will depend on their moisture content and the prevailing weather conditions when site grading activities take place. Soils that are too wet to properly compact could be dried by aeration during dry weather conditions or mixed with an additive such as cement or lime to stabilize the soil and facilitate compaction. If an additive is used, additional Best Management Practices (BMPs) for its use will need to be incorporated into the Temporary Erosion and Sedimentation Control plan (TESC) for the project.

If grading activities are planned during the wet winter months, or site soils become too wet to achieve adequate compaction, the owner or contractor should be prepared to treat soils with lime or cement, or import wet weather structural fill that meets the following grading requirements:

U.S. Sieve Size	Percent Passing
6 inches	100
No. 4	75 maximum
No. 200	5 maximum*

*Based on the 3/4-inch fraction

Prior to use, Terra Associates, Inc. should examine and test all materials to be imported to the site for use as structural fill.

Structural fill should be placed in uniform loose layers not exceeding 12 inches and compacted to a minimum of 95 percent of the soil's maximum dry density, as determined by American Society for Testing and Materials (ASTM) Test Designation D-698 (Standard Proctor). The moisture content of the soil at the time of compaction should be within two percent of its optimum, as determined by this same ASTM standard. In non-structural areas, the degree of compaction can be reduced to 90 percent. Structural fill placed in rights-of-way should conform to material and compaction specifications set forth by the applicable jurisdiction.

Preload

To limit post-construction settlements to tolerable levels, building construction should be delayed after raising grades with structural fill to allow settlement to occur under the fill load. With a minimum fill thickness of four feet, we estimate that total settlement under the preload fill will be in the range of four to six inches. It is estimated that 90 percent of the consolidation settlement under the preload fill will occur in about four to six weeks following full application of the fill.

To verify the amount of settlement and the time rate of movement, the preload program should be monitored by installing settlement markers. The settlement markers should be installed on the existing grade prior to placing any building or preload fills. Once installed, elevations of both the fill height and marker should be taken daily until the full height of the preload is in place. Once fully preloaded, readings should continue weekly until the anticipated settlements have occurred. A typical settlement marker detail is provided as Figure 3.

It is critical that the grading contractor recognize the importance of the settlement marker installations. All efforts must be made to protect the markers from damage during fill placement. It is difficult, if not impossible, to evaluate the progress of the preload program if the markers are damaged or destroyed by construction equipment. As a result, it may be necessary to install new markers and extend the surcharging time period in order to ensure that settlements have ceased and building construction can begin.

Following the successful completion of the preload program, with foundations supported on a minimum of two feet of granular structural fill, and dimensioned as recommended in Section 4.4 of this report, we estimate that post-construction settlements due to consolidation of the loose/soft native soils would range between about one-half inch and one inch.

4.3 Excavations

All excavations at the site associated with confined spaces, such as utility trenches, must be completed in accordance with local, state, or federal requirements. Based on current Washington Industrial Safety and Health Act (WISHA) regulations, the native site soils, existing fill soils, and new structural fill would be classified as Type C soils.

For properly dewatered excavations in Type C soils that are greater than 4 feet and less than 20 feet in depth, the side slopes should be laid back at an inclination of 1.5:1 (Horizontal:Vertical) or flatter. If there is insufficient room to complete the excavations in this manner, or if excavations greater than 20 feet in depth are planned, using temporary shoring to support the excavations may need to be considered.

Based on our study, groundwater seepage should be anticipated within excavations extending below native surface grades. Excavations extending below this depth will likely encounter groundwater seepage with volumes and flow rates sufficient to require some level of dewatering. Excavations that do not extend more than two feet below the groundwater table can likely be dewatered by conventional sump-pumping procedures along with a system of collection trenches. Deeper excavations will likely require dewatering by well points or isolated deep-pump wells. The utility subcontractor should be prepared to implement excavation dewatering by well point or deep-pump wells, as needed. This will be an especially critical consideration for any deep excavations such as stormwater detention vaults, lift stations, and sanitary sewer tie-ins.

This information is provided solely for the benefit of the owner and other design consultants and should not be construed to imply that Terra Associates, Inc. assumes responsibility for job site safety. It is understood that job site safety is the sole responsibility of the project contractor.

4.4 Foundations

The buildings can be supported on conventional spread footing foundations bearing on new structural fill placed as recommended in section 4.2 of this report or existing fill that is mechanically compacted in place. Perimeter foundations exposed to the weather should bear at a minimum depth of 18 inches below final exterior grades for frost protection. Interior foundations can be constructed at any convenient depth below the floor slab.

We recommend designing foundations for a net allowable bearing capacity of 2,500 pounds per square foot (psf). For short-term loads, such as wind and seismic, a one-third increase in this allowable capacity can be used.

For designing foundations to resist lateral loads, a base friction coefficient of 0.35 can be used. Passive earth pressures acting on the sides of the footings can also be considered. We recommend calculating this lateral resistance using an equivalent fluid weight of 300 pounds per cubic foot (pcf). We recommend not including the upper 12 inches of soil in this computation because it can be affected by weather or disturbed by future grading activity. This value assumes the foundations will be backfilled with structural fill, as described in Section 5.2 of this report. The values recommended include a safety factor of 1.5.

4.5 Slab-on-Grade Floors

Slab-on-grade floors may be supported on subgrades prepared as recommended in Section 4.2 of this report. Immediately below the floor slabs, we recommend placing a four-inch thick capillary break layer of clean, free-draining, coarse sand or fine gravel that has less than five percent passing the No. 200 sieve. This material will reduce the potential for upward capillary movement of water through the underlying soil and subsequent wetting of the floor slabs.

The capillary break layer will not prevent moisture intrusion through the slab caused by water vapor transmission. Where moisture by vapor transmission is undesirable, such as covered floor areas, a common practice is to place a durable plastic membrane on the capillary break layer and then cover the membrane with a layer of clean sand or fine gravel to protect it from damage during construction and aid in uniform curing of the concrete slab. It should be noted, if the sand or gravel layer overlying the membrane is saturated prior to pouring the slab, it will be ineffective in assisting in uniform curing of the slab and can actually serve as a water supply for moisture transmission through the slab and affecting floor coverings. Therefore, in our opinion, covering the membrane with a layer of sand or gravel should be avoided if floor slab construction occurs during the wet winter months and the layer cannot be effectively drained. We recommend floor designers and contractors refer to the current American Concrete Institute (ACI) Manual of Concrete Practice for further information regarding vapor barrier installation below slab-on-grade floors.

4.6 Lateral Earth Pressures for Wall Design

The magnitude of earth pressure development on retaining walls will partly depend on the quality and compaction of the wall backfill. We recommend placing and compacting wall backfill as structural fill, as described in Section 4.2. To prevent overstressing the walls during backfilling, heavy construction machinery should not be operated within five feet of the wall. Wall backfill in this zone should be compacted with hand-operated equipment. To prevent hydrostatic pressure development, wall drainage must also be installed. A typical wall drainage detail is shown on Figure 4. All drains should be routed to the storm sewer system or other approved point of controlled discharge.

With drainage properly installed, we recommend designing unrestrained walls for an active earth pressure equivalent to a fluid weighing 35 pounds per cubic foot (pcf). For restrained walls, an additional uniform load of 100 psf should be added to the 35 pcf. To account for typical traffic surcharge loading, the walls can be designed for an additional imaginary height of two feet (two-foot soil surcharge). For evaluation of wall performance under seismic loading, a uniform pressure equivalent to $8H$ psf, where H is the height of the below-grade portion of the wall should be applied in addition to the static lateral earth pressure. These values assume a horizontal backfill condition and that no other surcharge loading, sloping embankments, or adjacent buildings will act on the wall. If such conditions exist, then the imposed loading must be included in the wall design. Friction at the base of foundations and passive earth pressure will provide resistance to these lateral loads. Values for these parameters are provided in Section 4.4.

4.7 Infiltration Feasibility

With seasonal high groundwater levels residing at or near the existing ground surface, it is our opinion that onsite infiltration is not a viable option for stormwater management.

4.8 Stormwater Detention Facilities

Detention Ponds

We expect that stormwater detention ponds would be constructed primarily in the structural fill used to raise site grades. If pond depths extend below existing native surface grades, the functional depth of the pond will be limited by the seasonal high groundwater level.

If fill berms will be constructed, the berm locations should be stripped of topsoil, duff, and soils containing organic material prior to the placement of fill. Fill material required to construct perimeter containment berm should consist of silty soils with at least 25 percent fines that is compacted structurally, as recommended in Section 4.2 of this report.

Because of exposure to fluctuating stored water levels, soils exposed on the interior side slopes of the ponds will be subject to some risk of periodic shallow instability or sloughing. Establishing interior slopes at a 3:1 gradient will significantly reduce or eliminate this potential. Exterior berm slopes and interior slopes above the maximum water surface should be graded to a finished inclination no steeper than 2:1. Finished slope faces should be thoroughly compacted and vegetated to guard against erosion.

We should review stormwater management plans when they become available to verify suitability of soils in the planned locations and to provide supplemental discussion and recommendations, if needed.

Detention Vaults

The excavation for buried stormwater detention vault construction will likely expose native soils consisting of loose to medium dense silt or sand. We recommend supporting vault foundations on a minimum of two feet of structural fill that extends at least one foot beyond the edge of the foundation. Vault foundations should be designed using the parameters outlined in Section 4.4 of this report. Friction at the base of foundations and passive earth pressure will provide resistance to lateral loads. Values for these parameters are provided in Section 4.4.

The magnitude of earth pressures developing on the vault walls will depend in part on the quality and compaction of the wall backfill. We recommend placing and compacting wall backfill as structural fill, as recommended in the Section 4.2 of this report. Lateral earth pressures recommended in Section 4.6 can be used in designing the below-grade vault walls. If it is not possible to discharge collected water at the footing elevation, we recommend setting the invert elevation of the wall drainpipe equivalent to the outfall invert and connecting the drain to the outfall pipe for discharge. For any portion of the wall that falls below the invert elevation of the wall drain, an earth pressure equivalent to a fluid weighing 85 pcf should be used.

The vault structure will be subject to uplift pressures. The weight of the structure and the weight of the backfill soil above its foundation will provide resistance to uplift. A soil unit weight of 120 pcf can be used for the vault backfill provided the backfill is placed and compacted as structural fill as recommended above.

4.9 Drainage

Surface

Final exterior grades should promote free and positive drainage away from the building areas. We recommend providing a gradient of at least three percent for a minimum distance of ten feet from the building perimeter, except in paved locations. In paved locations, a minimum gradient of two percent should be provided, unless provisions are included for collection and disposal of surface water adjacent to the structure.

Subsurface

We recommend installing perimeter foundation drains adjacent to shallow foundations. The drains can be laid to grade at an invert elevation equivalent to the bottom of footing grade. The drains can consist of four-inch diameter perforated PVC pipe that is enveloped in washed pea gravel-sized drainage aggregate. The aggregate should extend six inches above and to the sides of the pipe. Roof and foundation drains should be tightlined separately to the storm drains. All drains should be provided with cleanouts at easily accessible locations.

4.10 Utilities

Utility pipes should be bedded and backfilled in accordance with American Public Works Association (APWA), or local jurisdictional specifications. As a minimum, trench backfill should be placed and compacted as structural fill, as described in Section 4.2 of this report. Most inorganic native and existing fill soils excavated on the site should be suitable for use as backfill material during dry weather conditions. However, if utility construction takes place during the wet winter months, or if utility excavations extend below groundwater levels, it may be necessary to import suitable wet weather fill for utility trench backfilling.

The utility contractor should also be prepared for encountering unstable soft soils below the pipe invert elevations. If not removed from below the pipe and replaced with crushed rock or additional bedding material, pipe deflections will occur as a result of the soil yielding and compressing in response to loading imposed by the trench backfill.

4.11 Pavements

Pavement subgrades should be prepared as described in Section 4.2 of this report. Regardless of the degree of relative compaction achieved, the subgrade must be firm and relatively unyielding before paving. The subgrade should be proofrolled with heavy construction equipment to verify this condition.

The pavement design section is dependent upon the supporting capability of the subgrade soils and the traffic conditions to which it will be subjected. We expect traffic at the facility will consist mainly of cars and light trucks, with occasional heavy traffic in the form of moving trucks and trash/recycle vehicles. With a stable subgrade prepared as recommended, we recommend the following pavement sections:

Light Traffic and Parking:

- 2 inches of hot mix asphalt (HMA) over 6 inches of crushed rock base (CRB)
- 4 inches of full depth HMA

Heavy Traffic:

- 3 inches of HMA over 8 inches of CRB
- 6 inches of full depth HMA

Soil cement stabilization or constructing a soil cement base for support of the pavement section can also be considered as an alternate to the above conventional pavement sections. Assuming a properly constructed soil cement base having a minimum thickness of 12 inches and a minimum 7-day compressive strength of 100 pounds per square inch (psi), a minimum HMA pavement thickness of 3 inches would be required for the heavy traffic areas. The design of the soil cement base should be completed using samples of the subgrade exposed at the time of construction.

The paving materials used should conform to the current Washington State Department of Transportation (WSDOT) specifications for ½-inch hot mix asphalt HMA and CRB.

Long-term pavement performance will depend on surface drainage. A poorly-drained pavement section will be subject to premature failure as a result of surface water infiltrating the subgrade soils and reducing their supporting capability. For optimum performance, we recommend surface drainage gradients of at least two percent. Some degree of longitudinal and transverse cracking of the pavement surface should be expected over time. Regular maintenance should be planned to seal cracks as they occur.

5.0 ADDITIONAL SERVICES

Terra Associates, Inc. should review the final designs and specifications in order to verify earthwork and foundation recommendations have been properly interpreted and implemented in project design. We should also provide geotechnical services during construction in order to observe compliance with our design concepts, specifications, and recommendations. This will allow for design changes if subsurface conditions differ from those anticipated prior to the start of construction.

6.0 LIMITATIONS

We prepared this report in accordance with generally accepted geotechnical engineering practices. This report is the copyrighted property of Terra Associates, Inc. and is intended for specific application to the Marysville 172 and 23 Apartments project in Marysville, Washington. This report is for the exclusive use of Marysville 172nd Development, LLC and their authorized representatives. No other warranty, expressed or implied, is made.

The analyses and recommendations presented in this report are based on data obtained from our onsite test pits and CPT data. Variations in soil conditions can occur, the nature and extent of which may not become evident until construction. If variations appear evident, Terra Associates, Inc. should be requested to reevaluate the recommendations in this report prior to proceeding with construction.

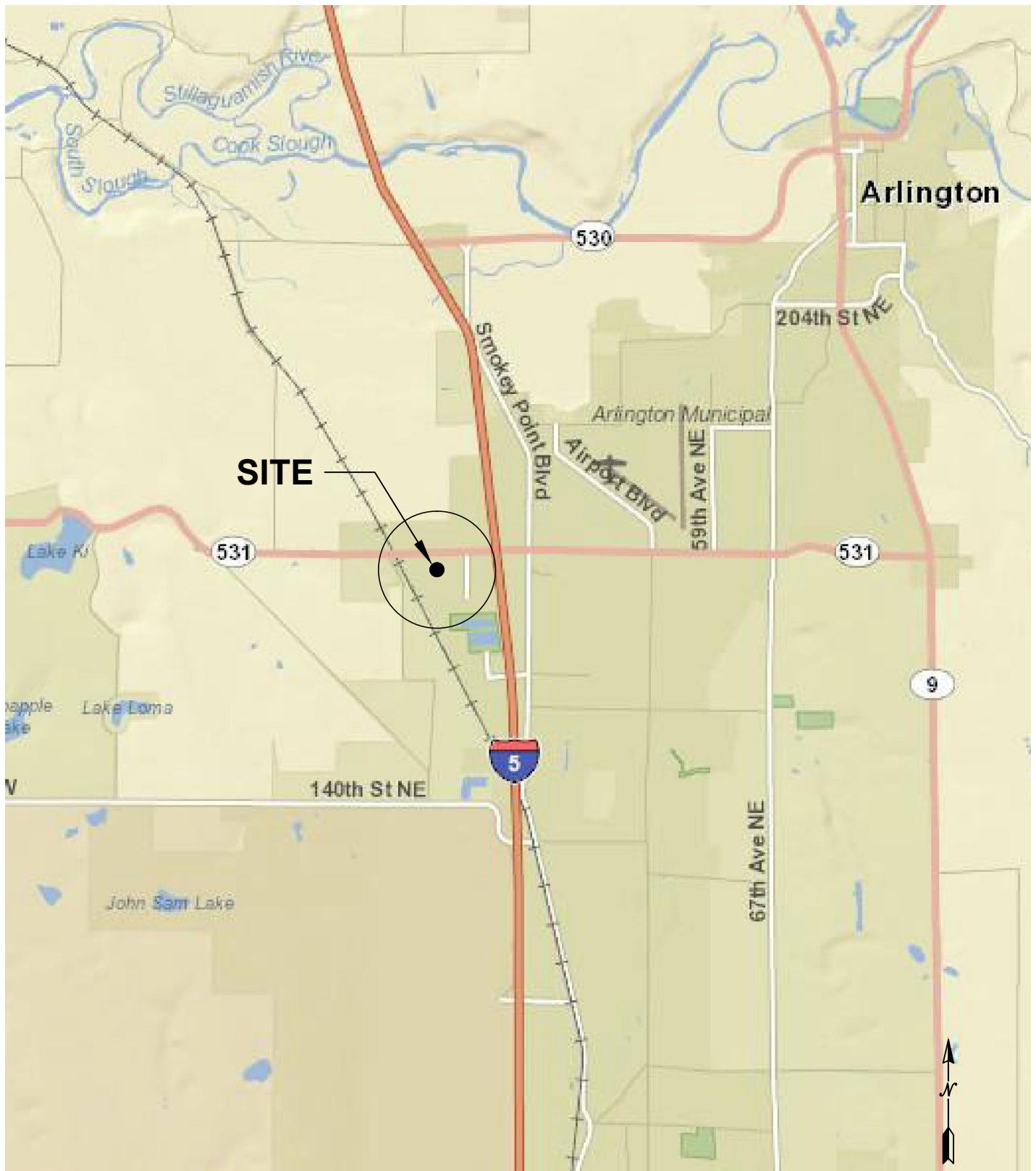

REFERENCE: WSDOT GEOPORTAL

NOT TO SCALE

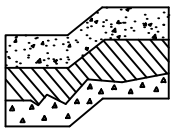

Terra Associates, Inc.

Consultants in Geotechnical Engineering
Geology and
Environmental Earth Sciences

VICINITY MAP
MARYSVILLE 172 and 23 APARTMENTS
MARYSVILLE, WASHINGTON

Proj. No.T-8541



Date MAR 2022

Figure 1



NOTE:
THIS SITE PLAN IS SCHEMATIC. ALL LOCATIONS AND DIMENSIONS ARE APPROXIMATE. IT IS INTENDED FOR REFERENCE ONLY AND SHOULD NOT BE USED FOR DESIGN OR CONSTRUCTION PURPOSES.

REFERENCE:
SCOPI

- LEGEND:**
-  APPROXIMATE TEST PIT LOCATION (DEC 2021)
 -  APPROXIMATE TEST PIT LOCATION (DEC 2006)
 -  APPROXIMATE CPT LOCATION (JAN 2007)

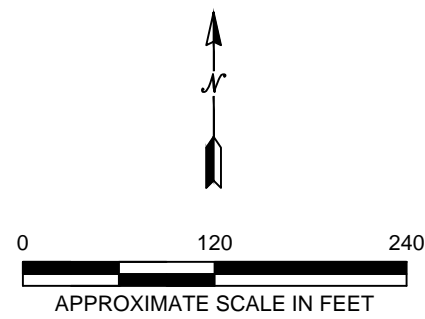

Terra Associates, Inc.
Consultants in Geotechnical Engineering
Geology and
Environmental Earth Sciences

EXPLORATION LOCATION PLAN
MARYSVILLE 172 and 23 APARTMENTS
MARYSVILLE, WASHINGTON

Proj. No.T-8541	Date MAR 2022	Figure 2
-----------------	---------------	----------

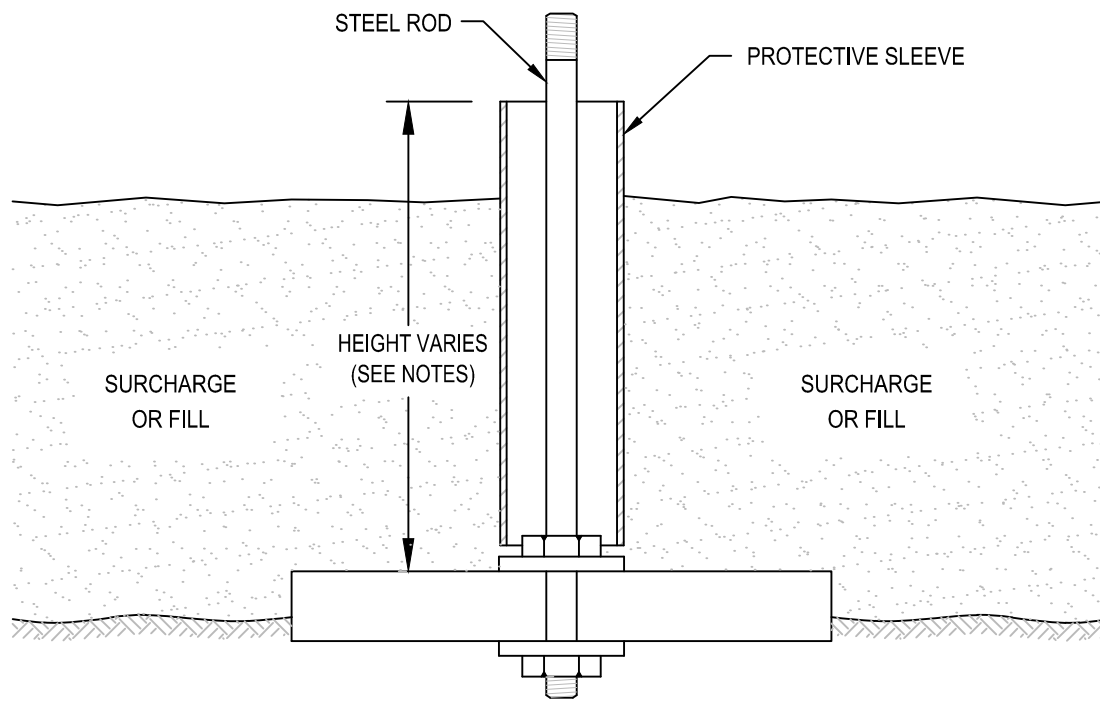

NOT TO SCALE

NOTES:

1. BASE CONSISTS OF 3/4" THICK, 2'x2' PLYWOOD WITH CENTER DRILLED 5/8" DIAMETER HOLE.
2. BEDDING MATERIAL, IF REQUIRED, SHOULD CONSIST OF CLEAN COARSE SAND.
3. MARKER ROD IS 1/2" DIAMETER STEEL ROD THREADED AT BOTH ENDS.
4. MARKER ROD IS ATTACHED TO BASE BY NUT AND WASHER ON EACH SIDE OF BASE.
5. PROTECTIVE SLEEVE SURROUNDING MARKER ROD SHOULD CONSIST OF 2" DIAMETER PLASTIC TUBING. SLEEVE IS NOT ATTACHED TO ROD OR BASE.
6. ADDITIONAL SECTIONS OF STEEL ROD CAN BE CONNECTED WITH THREADED COUPLINGS.
7. ADDITIONAL SECTIONS OF PLASTIC PROTECTIVE SLEEVE CAN BE CONNECTED WITH PRESS-FIT PLASTIC COUPLINGS.
8. STEEL MARKER ROD SHOULD EXTEND AT LEAST 6" ABOVE TOP OF PLASTIC PROTECTIVE SLEEVE.
9. PLASTIC PROTECTIVE SLEEVE SHOULD EXTEND AT LEAST 1" ABOVE TOP OF FILL SURFACE.

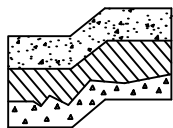

Terra Associates, Inc.

Consultants in Geotechnical Engineering
Geology and
Environmental Earth Sciences

TYPICAL SETTLEMENT MARKER DETAIL
MARYSVILLE 172 and 23 APARTMENTS
MARYSVILLE, WASHINGTON

Proj. No.T-8541

Date MAR 2022

Figure 3

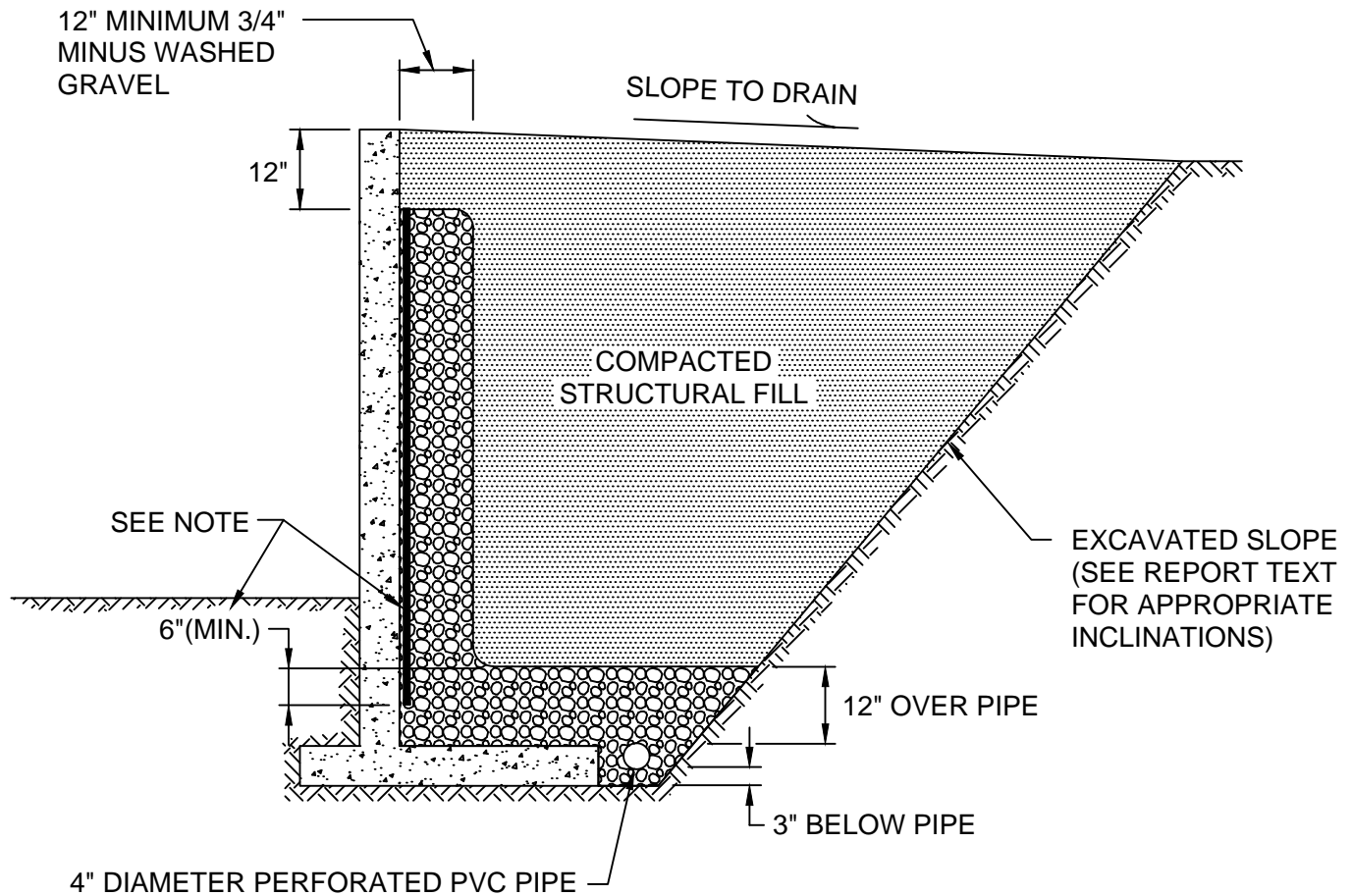

NOT TO SCALE

NOTE:

MIRADRAIN G100N PREFABRICATED DRAINAGE PANELS OR SIMILAR PRODUCT CAN BE SUBSTITUTED FOR THE 12-INCH WIDE GRAVEL DRAIN BEHIND WALL. DRAINAGE PANELS SHOULD EXTEND A MINIMUM OF SIX INCHES INTO 12-INCH THICK DRAINAGE GRAVEL LAYER OVER PERFORATED DRAIN PIPE.

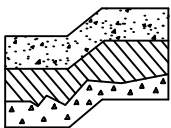

Terra Associates, Inc.

Consultants in Geotechnical Engineering
Geology and
Environmental Earth Sciences

TYPICAL WALL DRAINAGE DETAIL
MARYSVILLE 172 and 23 APARTMENTS
MARYSVILLE, WASHINGTON

Proj. No.T-8541

Date MAR 2022

Figure 4

**APPENDIX A
FIELD EXPLORATION AND LABORATORY TESTING**

**Marysville 172 and 23 Apartments
Marysville, Washington**

We explored subsurface conditions at the site in 24 test pits excavated to maximum depths ranging between about 6 and 12 feet using a track-mounted excavator. Our characterization of subsurface conditions also included information presented on the logs of two test pits and one 50-foot cone penetration test (CPT) that were conducted in the eastern portion of the site as part of previous geotechnical work by Terra Associates, Inc. in 2006 and 2007. The approximate test pit and CPT locations are shown on Figure 2. The exploration locations were approximately determined in the field by sighting and pacing from existing surface features. The Test Pit Logs are presented on Figures A-2 through A-27.



An engineering geologist from our office maintained a log of each test pit as it was excavated, classified the soil conditions encountered, and obtained representative soil samples. All soil samples were visually classified in the field in accordance with the Unified Soil Classification System. A copy of this classification is presented as Figure A-1.

Representative soil samples obtained from the test pits were placed in sealed plastic bags and taken to our laboratory for further examination and testing. The moisture content of each sample was measured and is reported on the Test Pit Logs. Grain size analyses were performed on six of the soil samples. The results are shown on Figures A-28 and A-29.

In Situ Engineering (Formerly Northwest Cone Exploration), under subcontract to Terra Associates, Inc., performed the CPT in January 2007 at a location selected by Terra Associates, Inc. The CPT consists of pushing an instrumented, approximately 1.5-inch diameter cone into the ground at a constant rate. During advancement, continuous measurements are made of the resistance to penetration of the cone and the friction of the outer surface of a sleeve. The cone is also equipped with a porous filter and a pressure transducer for measuring the generated groundwater or pore water pressure. Measurements of tip and sleeve frictional resistance, pore pressure, and interpreted soil conditions are summarized in graphical form on the attached CPT Log.

MAJOR DIVISIONS			LETTER SYMBOL	TYPICAL DESCRIPTION	
COARSE GRAINED SOILS	More than 50% material larger than No. 200 sieve size	GRAVELS More than 50% of coarse fraction is larger than No. 4 sieve	Clean Gravels (less than 5% fines)	GW	Well-graded gravels, gravel-sand mixtures, little or no fines.
				GP	Poorly-graded gravels, gravel-sand mixtures, little or no fines.
			Gravels with fines	GM	Silty gravels, gravel-sand-silt mixtures, non-plastic fines.
				GC	Clayey gravels, gravel-sand-clay mixtures, plastic fines.
	More than 50% material smaller than No. 200 sieve size	SANDS More than 50% of coarse fraction is smaller than No. 4 sieve	Clean Sands (less than 5% fines)	SW	Well-graded sands, sands with gravel, little or no fines.
				SP	Poorly-graded sands, sands with gravel, little or no fines.
			Sands with fines	SM	Silty sands, sand-silt mixtures, non-plastic fines.
				SC	Clayey sands, sand-clay mixtures, plastic fines.
FINE GRAINED SOILS	SILTS AND CLAYS Liquid Limit is less than 50%		ML	Inorganic silts, rock flour, clayey silts with slight plasticity.	
			CL	Inorganic clays of low to medium plasticity. (Lean clay)	
			OL	Organic silts and organic clays of low plasticity.	
	SILTS AND CLAYS Liquid Limit is greater than 50%		MH	Inorganic silts, elastic.	
			CH	Inorganic clays of high plasticity. (Fat clay)	
			OH	Organic clays of high plasticity.	
HIGHLY ORGANIC SOILS			PT	Peat.	

DEFINITION OF TERMS AND SYMBOLS

COHESIONLESS	<u>Density</u>	<u>Standard Penetration Resistance in Blows/Foot</u>	 2" OUTSIDE DIAMETER SPILT SPOON SAMPLER
	Very Loose Loose Medium Dense Dense Very Dense	0-4 4-10 10-30 30-50 >50	 2.4" INSIDE DIAMETER RING SAMPLER OR SHELBY TUBE SAMPLER  WATER LEVEL (Date) Tr TORVANE READINGS, tsf
COHESIVE	<u>Consistency</u>	<u>Standard Penetration Resistance in Blows/Foot</u>	Pp PENETROMETER READING, tsf
	Very Soft Soft Medium Stiff Stiff Very Stiff Hard	0-2 2-4 4-8 8-16 16-32 >32	DD DRY DENSITY, pounds per cubic foot LL LIQUID LIMIT, percent PI PLASTIC INDEX N STANDARD PENETRATION, blows per foot

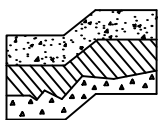

Terra Associates, Inc.
Consultants in Geotechnical Engineering
Geology and Environmental Earth Sciences

UNIFIED SOIL CLASSIFICATION SYSTEM
MARYSVILLE INTRACORP
MARYSVILLE, WASHINGTON

Proj. No.T-8541

Date MAR 2022

Figure A-1

LOG OF TEST PIT NO. 1

FIGURE A-2

PROJECT NAME: Marysville 172 and 23 Apartments **PROJ. NO:** T-8541 **LOGGED BY:** JCS

LOCATION: Marysville, Washington **SURFACE CONDITIONS:** Grass **APPROX. ELEV:** NA

DATE LOGGED: December 14, 2021 **DEPTH TO GROUNDWATER:** 4 ft **DEPTH TO CAVING:** 3-4 ft

Depth (ft)	Sample No.	Description	Consistency/ Relative Density	W (%)
0		18 inches Sod and Topsoil.		
1	1	Gray-brown SAND, fine grained, wet, mottled. (SP)		46.7
2	2			29.2
3	3	Gray SAND, fine grained, wet. (SP)		22.3
▼ 4		Gray SILT, moist to wet. (ML) Pp=0.75 tons/sf	Medium Dense	31.9
5	4			
6				
7				
8				
9				
10		Test pit terminated at 9 feet. Light to moderate groundwater seepage at 4 feet. Minor sloughing between 3 and 4 feet.		
11				
12				

NOTE: This subsurface information pertains only to this test pit location and should not be interpreted as being indicative of other locations at the site.

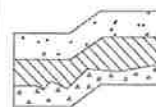

Terra Associates, Inc.
 Consultants in Geotechnical Engineering
 Geology and Environmental Earth Sciences

LOG OF TEST PIT NO. 2

FIGURE A-3

PROJECT NAME: Marysville 172 and 23 Apartments **PROJ. NO:** T-8541 **LOGGED BY:** JCS

LOCATION: Marysville, Washington **SURFACE CONDITIONS:** Grass **APPROX. ELEV:** NA

DATE LOGGED: December 14, 2021 **DEPTH TO GROUNDWATER:** 4 ft **DEPTH TO CAVING:** NA

Depth (ft)	Sample No.	Description	Consistency/ Relative Density	W (%)
0		8 inches Sod and Topsoil.		
1		Gray-brown SAND, fine to medium grained, moist to wet. (SP)	Medium Dense	
2				
3				
4		Gray-brown SAND with silt to silty SAND, fine to medium grained, wet. (SP-SM/SM)	Loose to Medium Dense	
5		Gray SILT, wet. (ML)		
6				
7				
8		Test pit terminated at 7 feet. Light to moderate groundwater seepage at 4 feet. Installed 2-inch diameter slotted PVC standpipe.		
9				
10				
11				
12				

NOTE: This subsurface information pertains only to this test pit location and should not be interpreted as being indicative of other locations at the site.

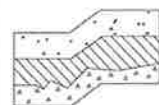

Terra Associates, Inc.
 Consultants in Geotechnical Engineering
 Geology and Environmental Earth Sciences

LOG OF TEST PIT NO. 3

FIGURE A-4

PROJECT NAME: Marysville 172 and 23 Apartments **PROJ. NO:** T-8541 **LOGGED BY:** JCS

LOCATION: Marysville, Washington **SURFACE CONDITIONS:** Grass **APPROX. ELEV:** NA

DATE LOGGED: December 14, 2021 **DEPTH TO GROUNDWATER:** 0.7 ft and 3-4 ft **DEPTH TO CAVING:** NA

Depth (ft)	Sample No.	Description	Consistency/ Relative Density	W (%)
0		8 inches Sod and Topsoil, wet.		
▼ 1		Gray-brown SAND with silt to silty SAND, fine grained, wet, mottled. (SP-SM/SM)		
2	1		Medium Dense	20.6
▼ 3		Gray SAND with silt, fine to medium grained, wet. (SP-SM)		
4	2			25.2
5		Gray SILT, wet. (ML)		
6			Loose to Medium Dense	
7				
8		Test pit terminated at 8 feet. Light groundwater seepage at 0.7 feet. Moderate groundwater seepage between 3 and 4 feet. Installed 2-inch diameter slotted PVC standpipe.		
9				
10				
11				
12				

NOTE: This subsurface information pertains only to this test pit location and should not be interpreted as being indicative of other locations at the site.

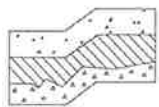

Terra Associates, Inc.
 Consultants in Geotechnical Engineering
 Geology and
 Environmental Earth Sciences

LOG OF TEST PIT NO. 4

FIGURE A-5

PROJECT NAME: Marysville 172 and 23 Apartments **PROJ. NO:** T-8541 **LOGGED BY:** JCS

LOCATION: Marysville, Washington **SURFACE CONDITIONS:** Grass **APPROX. ELEV:** NA

DATE LOGGED: December 14, 2021 **DEPTH TO GROUNDWATER:** 1.2 ft **DEPTH TO CAVING:** NA

Depth (ft)	Sample No.	Description	Consistency/ Relative Density	W (%)
0		8 inches Sod and Topsoil.		
1		Fill: Dark brown silty SAND with gravel, fine sand, fine to coarse gravel, wet. (SM)		
2	1	Gray-brown SILT, moist to wet, mottled, scattered fine organic fibers. (ML)	Medium Dense	32.7
3				
4				
5		Gray laminated SILT, moist to wet. (ML)		
6				
7	2	LL=44, PI=13		34.3
8				
9				
10				
11	3	Test pit terminated at 11 feet. Light groundwater seepage at about 1.2 feet.		38.8
12				

NOTE: This subsurface information pertains only to this test pit location and should not be interpreted as being indicative of other locations at the site.

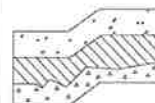

Terra Associates, Inc.
 Consultants in Geotechnical Engineering
 Geology and Environmental Earth Sciences

LOG OF TEST PIT NO. 5

FIGURE A-6

PROJECT NAME: Marysville 172 and 23 Apartments **PROJ. NO:** T-8541 **LOGGED BY:** JCS

LOCATION: Marysville, Washington **SURFACE CONDITIONS:** Grass **APPROX. ELEV:** NA

DATE LOGGED: December 14, 2021 **DEPTH TO GROUNDWATER:** 5-6 ft **DEPTH TO CAVING:** NA

Depth (ft)	Sample No.	Description	Consistency/ Relative Density	W (%)
0		20 inches Sod and Topsoil.		
1				
2		Gray-brown SILT, moist to wet, mottled, scattered fine organic fibers. (ML)		
3				
4				
5		Gray laminated SILT, moist to wet. (ML)	Medium Dense	
6				
7				
8				
9				
10		Test pit terminated at 9 feet. Localized light groundwater seepage between 5 and 6 feet.		
11				
12				

NOTE: This subsurface information pertains only to this test pit location and should not be interpreted as being indicative of other locations at the site.

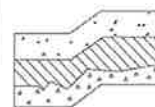

Terra Associates, Inc.
 Consultants in Geotechnical Engineering
 Geology and
 Environmental Earth Sciences

LOG OF TEST PIT NO. 6

FIGURE A-7

PROJECT NAME: Marysville 172 and 23 Apartments **PROJ. NO:** T-8541 **LOGGED BY:** JCS

LOCATION: Marysville, Washington **SURFACE CONDITIONS:** Grass **APPROX. ELEV:** NA

DATE LOGGED: December 14, 2021 **DEPTH TO GROUNDWATER:** >4 ft **DEPTH TO CAVING:** >3 ft

Depth (ft)	Sample No.	Description	Consistency/ Relative Density	W (%)
0		18 inches Sod and Topsoil.		
1		Orange-brown silty SAND, fine grained, moist to wet. oxidized. (SM)		
2	1			36.9
3	2	Gray-brown silty SAND, fine grained, wet. (SM)		25.1
4		Gray SAND, fine to medium grained, wet. (SP)	Medium Dense	
5				
6	3			24.0
7				
8				
9		Test pit terminated at 8.5 feet. Moderate groundwater seepage below 4 feet. Significant caving below 3 feet.		
10				
11				
12				

NOTE: This subsurface information pertains only to this test pit location and should not be interpreted as being indicative of other locations at the site.

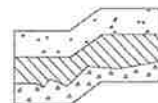

Terra Associates, Inc.
 Consultants in Geotechnical Engineering
 Geology and
 Environmental Earth Sciences

LOG OF TEST PIT NO. 7

FIGURE A-8

PROJECT NAME: Marysville 172 and 23 Apartments PROJ. NO: T-8541 LOGGED BY: JCS

LOCATION: Marysville, Washington SURFACE CONDITIONS: Grass APPROX. ELEV: NA

DATE LOGGED: December 14, 2021 DEPTH TO GROUNDWATER: >3 ft DEPTH TO CAVING: >3 ft

Depth (ft)	Sample No.	Description	Consistency/ Relative Density	W (%)
0		10 inches Sod and Topsoil.		
1		Orange-brown silty SAND, fine grained, moist to wet, oxidized. (SM)		
2		Gray-brown SAND, fine to medium grained, wet.	Medium Dense	
3				
4				
5		Gray-brown SAND, fine to coarse grained, scattered fine gravel, wet. (SP)		
6		Test pit terminated at 6 feet due to caving. Moderate to heavy groundwater seepage below 3 feet. Significant caving below 3 feet.		
7				
8				
9				
10				
11				
12				

NOTE: This subsurface information pertains only to this test pit location and should not be interpreted as being indicative of other locations at the site.

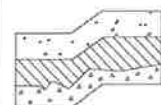

Terra Associates, Inc.
 Consultants in Geotechnical Engineering
 Geology and
 Environmental Earth Sciences

LOG OF TEST PIT NO. 8

FIGURE A-9

PROJECT NAME: Marysville 172 and 23 Apartments **PROJ. NO:** T-8541 **LOGGED BY:** JCS

LOCATION: Marysville, Washington **SURFACE CONDITIONS:** Grass **APPROX. ELEV:** NA

DATE LOGGED: December 14, 2021 **DEPTH TO GROUNDWATER:** 3-5 ft **DEPTH TO CAVING:** 2-5 ft

Depth (ft)	Sample No.	Description	Consistency/ Relative Density	W (%)
0		12 inches Sod and Topsoil.		
1		Brown SAND, fine to medium grained, moist to wet. (SP)	Medium Dense	21.5
2	1	Gray SAND, fine to coarse grained, scattered fine gravel, wet. (SP)		
3				
4	2		Very Soft	26.8
5		Gray silghtly clayey to clayey SILT, wet. (ML)		
6	3			
7				
8		Test pit terminated at 8 feet due to caving. Heavy groundwater serepage between 3 and 5 feet. Significant caving between 2 and 5 feet.		
9				
10				
11				
12				

NOTE: This subsurface information pertains only to this test pit location and should not be interpreted as being indicative of other locations at the site.

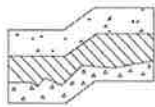

Terra Associates, Inc.
 Consultants in Geotechnical Engineering
 Geology and
 Environmental Earth Sciences

LOG OF TEST PIT NO. 9

FIGURE A-10

PROJECT NAME: Marysville 172 and 23 Apartments **PROJ. NO:** T-8541 **LOGGED BY:** JCS

LOCATION: Marysville, Washington **SURFACE CONDITIONS:** Grass **APPROX. ELEV:** NA

DATE LOGGED: December 14, 2021 **DEPTH TO GROUNDWATER:** >4 ft **DEPTH TO CAVING:** >3 ft

Depth (ft)	Sample No.	Description	Consistency/ Relative Density	W (%)
0		6 inches Sod and Topsoil.		
1		Brown silty SAND, fine grained, moist. (SM)		
2				
3		Gray SAND, fine grained, moist to wet. (SP)	Medium Dense	15.9
4		Gray SAND with gravel, fine to coarse sand, fine to coarse gravel, wet. (SP)		
5	1			
6				
7		Test pit terminated at 7 feet due to caving. Moderate groundwater seepage below 4 feet. Significant caving below 3 feet.		
8				
9				
10				
11				
12				

NOTE: This subsurface information pertains only to this test pit location and should not be interpreted as being indicative of other locations at the site.

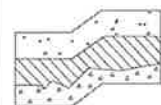

Terra Associates, Inc.
 Consultants in Geotechnical Engineering
 Geology and
 Environmental Earth Sciences

LOG OF TEST PIT NO. 10

FIGURE A-11

PROJECT NAME: Marysville 172 and 23 Apartments **PROJ. NO:** T-8541 **LOGGED BY:** JCS

LOCATION: Marysville, Washington **SURFACE CONDITIONS:** Grass **APPROX. ELEV:** NA

DATE LOGGED: December 14, 2021 **DEPTH TO GROUNDWATER:** 4 - 6.5 ft **DEPTH TO CAVING:** 4 - 6.5 ft

Depth (ft)	Sample No.	Description	Consistency/ Relative Density	W (%)
0		18 inches Sod and Topsoil.		
1		Brown SAND, fine to medium grained, scattered fine gravel, moist, oxidized. (SP)		
2				
3	1	Gray SAND with gravel, fine to coarse sand, fine to coarse gravel, wet. (SP)	Medium Dense	21.4
4				
5	2			22.6
6				
7		Gray slightly clayey to clayey SILT, wet. (ML)	Soft	
8		Test pit terminated at 7 feet due to caving. Moderate to heavy groundwater seepage between 4 feet and 6.5 feet. Significant caving between 4 feet and 6.5 feet. Installed 2-inch diameter slotted PVC standpipe.		
9				
10				
11				
12				

NOTE: This subsurface information pertains only to this test pit location and should not be interpreted as being indicative of other locations at the site.

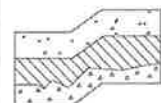

Terra Associates, Inc.
 Consultants in Geotechnical Engineering
 Geology and
 Environmental Earth Sciences

LOG OF TEST PIT NO. 11

FIGURE A-12

PROJECT NAME: Marysville 172 and 23 Apartments **PROJ. NO:** T-8541 **LOGGED BY:** JCS

LOCATION: Marysville, Washington **SURFACE CONDITIONS:** Grass **APPROX. ELEV:** NA

DATE LOGGED: December 14, 2021 **DEPTH TO GROUNDWATER:** 4-7 ft **DEPTH TO CAVING:** 3-7 ft

Depth (ft)	Sample No.	Description	Consistency/ Relative Density	W (%)
0		18 inches Sod and Topsoil.		
1		Orange-brown to gray-brown silty SAND, fine grained, moist, oxidized. (SM)		
2		Brown to gray SAND, fine to medium grained, scattered fine to coarse gravel, moist to wet. (SP)		
3			Medium Dense	
4		Gray SAND with gravel, fine to coarse sand, fine to coarse gravel, wet. (SP)		
5				
6				
7				
8	1	Gray silty CLAY to clayey SILT, wet. (CL/ML) LL=42, PI=14	Very Soft	55.9
9		Test pit terminated at 8 feet due to caving. Light to moderate groundwater seepage between 4 and 7 feet. Significant caving between 3 and 7 feet.		
10				
11				
12				

NOTE: This subsurface information pertains only to this test pit location and should not be interpreted as being indicative of other locations at the site.



Terra Associates, Inc.
 Consultants in Geotechnical Engineering
 Geology and
 Environmental Earth Sciences

LOG OF TEST PIT NO. 12

FIGURE A-13

PROJECT NAME: Marysville 172 and 23 Apartments **PROJ. NO:** T-8541 **LOGGED BY:** JCS

LOCATION: Marysville, Washington **SURFACE CONDITIONS:** Grass **APPROX. ELEV:** NA

DATE LOGGED: December 14, 2021 **DEPTH TO GROUNDWATER:** 5-6 ft **DEPTH TO CAVING:** 3-6 ft

Depth (ft)	Sample No.	Description	Consistency/ Relative Density	W (%)
0		18 inches Sod and Topsoil.		
1		Orange-brown to gray-brown silty SAND, fine grained, moist, oxidized. (SM)		
2	1		Medium Dense	34.4
3		Gray SAND, fine to medium grained, trace of fine to coarse gravel, wet. (SP)		
4		Gray SAND with gravel, fine to coarse sand, fine to coarse gravel, wet. (SP)		
5				
6		Gray clayey SILT to silty CLAY, wet. (ML/CL)		
7			Very Soft	
8		Test pit terminated at 8 feet due to caving. Moderate groundwater seepage between 5 and 6 feet. Significant caving between 3 and 6 feet. Installed 2-inch diameter slotted PVC standpipe.		
9				
10				
11				
12				

NOTE: This subsurface information pertains only to this test pit location and should not be interpreted as being indicative of other locations at the site.

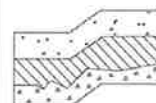

Terra Associates, Inc.
 Consultants in Geotechnical Engineering
 Geology and Environmental Earth Sciences

LOG OF TEST PIT NO. 14 (TP-2 Lot - 00900)

FIGURE A-15

PROJECT NAME: Marysville 172 and 23 Apartments **PROJ. NO:** T-8541-1 **LOGGED BY:** NRH

LOCATION: Marysville, Washington **SURFACE CONDITIONS:** Grass/Bare Soil **APPROX. ELEV:** NA

DATE LOGGED: December 20, 2021 **DEPTH TO GROUNDWATER:** NA **DEPTH TO CAVING:** NA

Depth (ft)	Sample No.	Description	Consistency/ Relative Density	W (%)
0		Fill: Light brown silty SAND with gravel, fine sand, fine to coarse gravel, moist, scattered concrete and metal debris, trace of wood debris. (SM)		
1				
2				
3				
4	1	No sheen, No odor, 0.0 ppm PID Headspace.		
5			Medium Dense	
6				
7	2	No sheen, No odor, 0.0 ppm PID Headspace.		
8				
9		Light brown to gray silty SAND with gravel, fine sand, fine to coarse gravel, moist. (SM)		
10				
11		Test pit terminated at 10.5 feet. No groundwater seepage.		
12				

NOTE: This subsurface information pertains only to this test pit location and should not be interpreted as being indicative of other locations at the site.

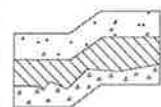

Terra Associates, Inc.
 Consultants in Geotechnical Engineering
 Geology and Environmental Earth Sciences

LOG OF TEST PIT NO. 16 (TP-4 Lot - 00900)

FIGURE A-17

PROJECT NAME: Marysville 172 and 23 Apartments PROJ. NO: T-8541-1 LOGGED BY: NRH

LOCATION: Marysville, Washington SURFACE CONDITIONS: Grass/Bare Soil APPROX. ELEV: NA

DATE LOGGED: December 20, 2021 DEPTH TO GROUNDWATER: NA DEPTH TO CAVING: NA

Depth (ft)	Sample No.	Description	Consistency/ Relative Density	W (%)
0		Fill: Tan silty SAND with gravel, fine to medium sand, fine to coarse gravel, moist. (SM)		
1				
2				
3	1	No sheen, No odor, 0.0 ppm PID Headspace.	Medium Dense	
4				
5				
6	2	No sheen, No odor, 0.0 ppm PID Headspace.		
7		Dark brown organic SILT, moist (OL).	Stiff	
8		Test pit terminated at 7.5 feet. No groundwater seepage.		
9				
10				
11				
12				

NOTE: This subsurface information pertains only to this test pit location and should not be interpreted as being indicative of other locations at the site.

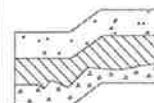

Terra Associates, Inc.
 Consultants in Geotechnical Engineering
 Geology and
 Environmental Earth Sciences

LOG OF TEST PIT NO. 17 (TP-5 Lot - 00900)

FIGURE A-18

PROJECT NAME: Marysville 172 and 23 Apartments **PROJ. NO:** T-8541-1 **LOGGED BY:** NRH

LOCATION: Marysville, Washington **SURFACE CONDITIONS:** Grass/Bare Soil **APPROX. ELEV:** NA

DATE LOGGED: December 20, 2021 **DEPTH TO GROUNDWATER:** NA **DEPTH TO CAVING:** NA

Depth (ft)	Sample No.	Description	Consistency/ Relative Density	W (%)
0		Fill: Brown silty SAND with gravel, fine to medium sand, fine to coarse gravel, moist, trace of wood and plastic debris. (SM)		
1				
2				
3	1	No sheen, No odor, 0.0 ppm PID Headspace.	Medium Dense	
4				
5				
6				
7	2	No sheen, No odor, 0.0 ppm PID Headspace.		
8				
9		Dark brown organic sandy SILT, moist. (OL)	Stiff	
10		Test pit terminated at 9.5 feet. No groundwater seepage.		
11				
12				

NOTE: This subsurface information pertains only to this test pit location and should not be interpreted as being indicative of other locations at the site.

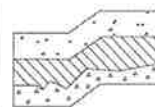

Terra Associates, Inc.
 Consultants in Geotechnical Engineering
 Geology and Environmental Earth Sciences

LOG OF TEST PIT NO. 20 (TP-8 Lot - 00900)

FIGURE A-21

PROJECT NAME: Marysville 172 and 23 Apartments **PROJ. NO:** T-8541-1 **LOGGED BY:** NRH

LOCATION: Marysville, Washington **SURFACE CONDITIONS:** Grass/Bare Soil **APPROX. ELEV:** NA

DATE LOGGED: December 20, 2021 **DEPTH TO GROUNDWATER:** NA **DEPTH TO CAVING:** NA

Depth (ft)	Sample No.	Description	Consistency/ Relative Density	W (%)
0		Fill: Gray and brown silty SAND with gravel, fine sand, fine to coarse gravel, moist, trace of wood and plastic debris. (SM)		
1				
2				
3	1	No sheen, No odor, 0.0 ppm PID Headspace.		
4				
5			Medium Dense	
6				
7	2	No sheen, No odor, 0.0 ppm PID Headspace.		
8				
9				
10		Brown SAND with gravel, fine to medium sand, fine to coarse gravel, moist. (SP)		
11		Test pit terminated at 11 feet. No groundwater seepage.		
12				
13				
14				
15				

NOTE: This subsurface information pertains only to this test pit location and should not be interpreted as being indicative of other locations at the site.

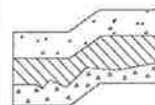

Terra Associates, Inc.
 Consultants in Geotechnical Engineering
 Geology and
 Environmental Earth Sciences

LOG OF TEST PIT NO. 21

FIGURE A-22

PROJECT NAME: Marysville 172 and 23 Apartments **PROJ. NO:** T-8541 **LOGGED BY:** NRH

LOCATION: Marysville, Washington **SURFACE CONDITIONS:** Grass/Bare Soil **APPROX. ELEV:** NA

DATE LOGGED: December 20, 2021 **DEPTH TO GROUNDWATER:** NA **DEPTH TO CAVING:** NA

Depth (ft)	Sample No.	Description	Consistency/ Relative Density	W (%)
0 1 2 3 4 5 6 7 8 9 10 11 12	1 2	<p>Fill: Gray and brown silty SAND with gravel, fine sand, fine to coarse gravel, moist, trace of wood and plastic debris. (SM)</p>	Medium Dense	
		Brown SAND, fine-grained, moist. (SP)		
		Test pit terminated at 9.5 feet. No groundwater seepage.		

NOTE: This subsurface information pertains only to this test pit location and should not be interpreted as being indicative of other locations at the site.

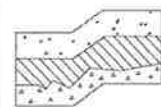

Terra Associates, Inc.
 Consultants in Geotechnical Engineering
 Geology and
 Environmental Earth Sciences

LOG OF TEST PIT NO. 23 (TP-11 Lot - 00900)

FIGURE A-24

PROJECT NAME: Marysville 172 and 23 Apartments **PROJ. NO:** T-8541-1 **LOGGED BY:** NRH

LOCATION: Marysville, Washington **SURFACE CONDITIONS:** Grass/Bare Soil **APPROX. ELEV:** NA

DATE LOGGED: December 20, 2021 **DEPTH TO GROUNDWATER:** NA **DEPTH TO CAVING:** NA

Depth (ft)	Sample No.	Description	Consistency/ Relative Density	W (%)
0		Fill: Gray and brown silty SAND with gravel, fine to medium sand, fine to coarse gravel, moist. (SM)		
1				
2				
3				
4	1	No sheen, No odor, 0.0 ppm PID Headspace.	Medium Dense	
5				
6				
7	2	No sheen, No odor, 0.0 ppm PID Headspace.		
8				
9				
10		Brown organic SILT to sandy SILT, moist. (OL/ML)	Stiff	
11		Test pit terminated at 10.5 feet. No groundwater seepage.		
12				

NOTE: This subsurface information pertains only to this test pit location and should not be interpreted as being indicative of other locations at the site.

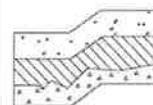

Terra Associates, Inc.
 Consultants in Geotechnical Engineering
 Geology and Environmental Earth Sciences

LOG OF TEST PIT NO. 24

FIGURE A-25

PROJECT NAME: Marysville 172 and 23 Apartments **PROJ. NO:** T-8541 **LOGGED BY:** NRH

LOCATION: Marysville, Washington **SURFACE CONDITIONS:** Grass/Bare Soil **APPROX. ELEV:** NA

DATE LOGGED: December 20, 2021 **DEPTH TO GROUNDWATER:** NA **DEPTH TO CAVING:** 1-6 feet

Depth (ft)	Sample No.	Description	Consistency/ Relative Density	W (%)
0		Fill: Light brown SAND and silty SAND, fine to medium grained, wet. (SP and SM)	Loose to Medium Dense	
1				
2				
3				
4	1			
5				
6		Fill: Brown silty SAND with gravel, fine sand, fine to coarse gravel, moist. (SM)	Medium Dense	
7	2			
8				
9		Test pit terminated at 9 feet due to caving. No groundwater seepage. Significant caving between 1 and 6 feet.		
10				
11				
12				

NOTE: This subsurface information pertains only to this test pit location and should not be interpreted as being indicative of other locations at the site.

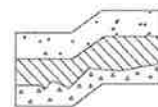

Terra Associates, Inc.
 Consultants in Geotechnical Engineering
 Geology and
 Environmental Earth Sciences

LOG OF TEST PIT NO. 1 (2006)

FIGURE A-26

PROJECT NAME: Sather Farms **PROJ. NO:** T-6018 **LOGGED BY:** DKW

LOCATION: Marysville, Washington **SURFACE CONDITIONS:** Firm, Long Grass **APPROX. ELEV:** NA

DATE LOGGED: December 20, 2006 **DEPTH TO GROUNDWATER:** 4 ft **DEPTH TO CAVING:** >4 ft

Depth (ft)	Sample No.	Description	Consistency/ Relative Density	W (%)
0		2 inches Sod and Topsoil.		
1		Brown silty SAND, moist. (SM)		
2		Reddish-brown SAND, fine grained, moist. (SP)		
3	1		Medium Dense	22.4
4		Gray SAND, medium grained, wet. (SP)		
5				
6				
7				
8		Test pit terminated at 7.5 feet. Groundwater seepage observed below 4 feet. Caving below 4 feet.		
9				
10				

NOTE: This subsurface information pertains only to this test pit location and should not be interpreted as being indicative of other locations at the site.

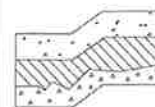

Terra Associates, Inc.
 Consultants in Geotechnical Engineering
 Geology and Environmental Earth Sciences

LOG OF TEST PIT NO. 2 (2006)

FIGURE A-27

PROJECT NAME: Sather Farms **PROJ. NO.:** T-6018 **LOGGED BY:** DKW

LOCATION: Marysville, Washington **SURFACE CONDITIONS:** Tall Grass, Firm **APPROX. ELEV.:** NA

DATE LOGGED: December 20, 2006 **DEPTH TO GROUNDWATER:** 5.5 ft **DEPTH TO CAVING:** >5 ft

Depth (ft)	Sample No.	Description	Consistency/ Relative Density	W (%)
0		2 inches Sod and Topsoil.		
1		Brown silty SAND, moist. (SM)	Medium Dense	23.7
2	1	Reddish-brown SAND, fine grained, moist. (SP)		
3		Gray SAND, fine grained, wet. (SP)	Loose to Medium Dense	
4				
5				
6				
7		Test pit terminated at 6.5 feet. Groundwater seepage observed below 5.5 feet. Caving below 5 feet.		
8				
9				
10				

NOTE: This subsurface information pertains only to this test pit location and should not be interpreted as being indicative of other locations at the site.

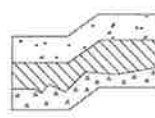

Terra
Associates, Inc.
Consultants in Geotechnical Engineering
Geology and
Environmental Earth Sciences

Particle Size Distribution Report

