



2828 Colby Avenue
Suite 200
Everett, WA 98201
425.708.8275

87th Townhomes Traffic Impact Analysis

Jurisdiction: City of Marysville

October 2023



TABLE OF CONTENTS

- 1. DEVELOPMENT IDENTIFICATION 1
- 2. METHODOLOGY 1
- 3. TRIP GENERATION 3
- 4. TRIP DISTRIBUTION 4
 - 4.1 2025 Opening Year 4
 - 4.2 2031 Horizon Year 7
- 5. INTERSECTION LEVEL OF SERVICE ANALYSIS 7
 - 5.1 Turning Movement Calculations 10
 - 5.2 Level of Service Calculations 10
- 6. ACCESS ANALYSIS 17
- 7. TRAFFIC MITIGATION FEES 17
 - 7.1 City of Marysville 17
 - 7.2 City of Lake Stevens 17
 - 7.3 Snohomish County 18
 - 7.4 Washington State Department of Transportation 18
- 8. CONCLUSIONS 18

LIST OF FIGURES

- Figure 1: Site Vicinity Map 2
- Figure 2: Opening Year Trip Distribution – AM Peak-Hour 5
- Figure 3: Opening Year Trip Distribution – PM Peak- Hour 6
- Figure 4: 2031 Horizon Year Trip Distribution – AM Peak-Hour 8
- Figure 5: 2031 Horizon Year Trip Distribution – PM Peak-Hour 9
- Figure 6: 2022 Existing Turning Movements 11
- Figure 7: 2025 Baseline Turning Movements 12
- Figure 8: 2025 Opening Year Turning Movements 13
- Figure 9: 2031 Baseline Turning Movements 14
- Figure 10: 2031 Horizon Year Turning Movements 15

LIST OF TABLES

- Table 1: Level of Service Criteria 3
- Table 2: Trip Generation Summary - Weekday 4
- Table 3: Level of Service Summary – 2025 Opening Year Conditions 16
- Table 4: Level of Service Summary – 2031 Horizon Year Conditions 16

ATTACHMENTS

City of Marysville Trip Distributions A
 Count Data..... B
 Turning Movement Calculations C
 Level of Service Calculations..... D
 WSDOT Exhibit C List..... E

1. DEVELOPMENT IDENTIFICATION

Kimley-Horn and Associates, Inc. has been retained to provide a traffic impact analysis for the proposed 87th Townhomes development. This report is intended to provide the City of Marysville, Snohomish County, and the Washington State Department of Transportation (WSDOT) with the necessary trip generation, trip distribution and level of service information to facilitate their reviews of the development. Additionally, this report addresses comments from City of Marysville staff dated November 4, 2022. The 87th Townhomes development is located along the east side of 87th Avenue NE at the future 40th Street NE alignment. A site vicinity map is included in Figure 1. The development is proposed to consist of 189 single-family attached residential units.

Brad Lincoln, responsible for this report and traffic analysis, is a licensed professional engineer (Civil) in the State of Washington and member of the Washington State section of ITE.

2. METHODOLOGY

The analysis contained in this report is based on the City of Marysville traffic impact analysis guidelines, which requires the analysis of intersections impacted with 25 or more PM peak-hour trips. The trip generation calculations are based on average trip generation rates published in the Institute of Transportation Engineers (ITE) *Trip Generation Manual, 11th Edition (2021)*. The trip distribution is based on the approved distributions provided by the City of Marysville for the *Whiskey Ridge East* area.

The level of service analysis at the study intersections has been performed in accordance with the *Highway Capacity Manual (HCM) 6th Edition*. Congestion is generally measured in terms of level of service (LOS). Road facilities and intersections are rated between LOS A and LOS F, with LOS A being free flow and LOS F being forced flow or over-capacity conditions. A summary of the level of service criteria is included in Table 1.

Date: February 03, 2023 - 4:29pm / User: jacobmillar
Path: K:\SNO_HFD\2022\22-013_87th Townhomes\Figures\87th Ave Figures_Corrected.dwg / Xref: WSDOTSeed3D

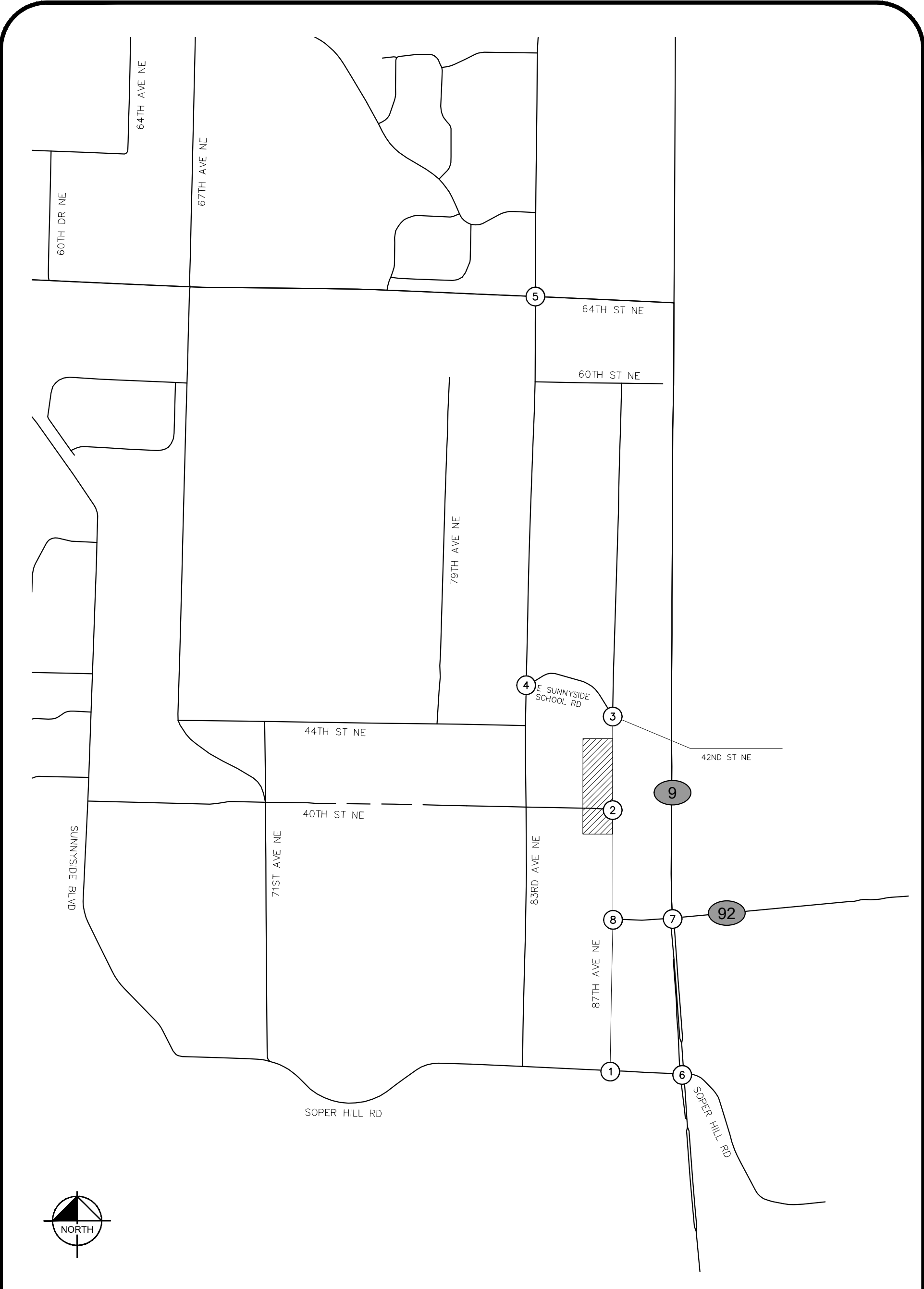

LEGEND



DEVELOPMENT SITE



STUDY INTERSECTION

87TH TOWNHOMES

CITY OF MARYSVILLE

FIGURE 1
SITE VICINITY MAP

Table 1: Level of Service Criteria

Level of ¹ Service	Expected Delay	Intersection Control Delay (Seconds per Vehicle)	
		Unsignalized Intersections	Signalized/ Roundabout Intersections
A	Little/No Delay	≤10	≤10
B	Short Delays	>10 and ≤15	>10 and ≤20
C	Average Delays	>15 and ≤25	>20 and ≤35
D	Long Delays	>25 and ≤35	>35 and ≤55
E	Very Long Delays	>35 and ≤50	>55 and ≤80
F	Extreme Delays ²	>50	>80

The level of service at two-way stop-controlled intersections is based on the average delay for the stop approach with the highest delay. The level of service at all-way stop-controlled intersections, roundabouts, and signalized intersections is based on the average delay for all vehicles. The level of service analysis has been performed utilizing the *Synchro 11.1, Build 1* software for signalized and stop-controlled intersections. This software applies the operational analysis methodology of the current *Highway Capacity Manual 6th Edition (HCM)*. The level of service at roundabout intersections have been completed using the *SIDRA Intersection 9.0* software. The City of Marysville identifies acceptable level of service as LOS D.

3. TRIP GENERATION

The trip generation calculations for the 87th Townhomes development are based on data published by the Institute of Transportation Engineers (ITE) in the *Trip Generation Manual, 11th Edition (2021)*. The average trip generation rates for ITE Land Use Code 215, Single-Family Attached Housing, were used for the trip generation calculations. The weekday trip generation calculations for the 87th Townhomes development are summarized in Table 2.

¹ **Source:** *Highway Capacity Manual 6th Edition*.

LOS A: Free-flow traffic conditions, with minimal delay to stopped vehicles (no vehicle is delayed longer than one cycle at signalized intersection).

LOS B: Generally stable traffic flow conditions.

LOS C: Occasional back-ups may develop, but delay to vehicles is short term and still tolerable.

LOS D: During short periods of the peak hour, delays to approaching vehicles may be substantial but are tolerable during times of less demand (i.e. vehicles delayed one cycle or less at signal).

LOS E: Intersections operate at or near capacity, with long queues developing on all approaches and long delays.

LOS F: Jammed conditions on all approaches with excessively long delays and vehicles unable to move at times.

² When demand volume exceeds the capacity of the lane, extreme delays will be encountered with queuing which may cause severe congestion affecting other traffic movements in the intersection.

Table 2: Trip Generation Summary - Weekday

189 Single-Family Attached Housing	Average Daily Trips			AM Peak-Hour Trips			PM Peak-Hour Trips		
	In	Out	Total	Inbound	In	Out	Total	Outbound	In
Generation Rate	7.20 trips per unit			0.48 trips per unit			0.57 trips per unit		
Splits	50%	50%	100%	31%	69%	100%	57%	43%	100%
Trips	680.40	680.40	1,360.80	28.12	62.60	90.72	61.41	46.32	107.73

The 87th Townhomes development is anticipated to generate approximately 1,361 average daily trips with approximately 91 AM peak-hour trips and approximately 108 PM peak-hour trips.

4. TRIP DISTRIBUTION

The trip distribution for the 87th Townhomes development is based on distributions provided by the City of Marysville for new developments in the site vicinity based on the *Whiskey Ridge East* distribution. The trip distribution has been evaluated for the 2025 Opening Year conditions and the 2031 Horizon Year conditions.

4.1 2025 Opening Year

The opening year trip distribution is based on the existing roadway network. It is anticipated that 28% of the trips generated by the development will travel to and from the north, twenty-five percent along 83rd Avenue NE and three percent along SR-9. It is anticipated that 8% of the trips generated by the development will travel to and from the east, five percent along SR-92 and three percent along Soper Hill Road. Approximately 50% of the trips generated by the development will travel to and from the south along SR-9. The remaining 14% of the trips generated by the development will travel to and from the west, five percent along 44th Street NE and nine percent along Soper Hill Road. Detailed trip distributions are shown in Figure 2 and Figure 3 for the weekday AM and PM peak-hours, respectively.

Date: February 06, 2023 3:26pm / User: jacobmiller
 Path: K:\SNO_PFD\2022\22-013_87th Townhomes\Figures\87th Ave Figures_Corrected.dwg / Xref: WSDOTSeed3D

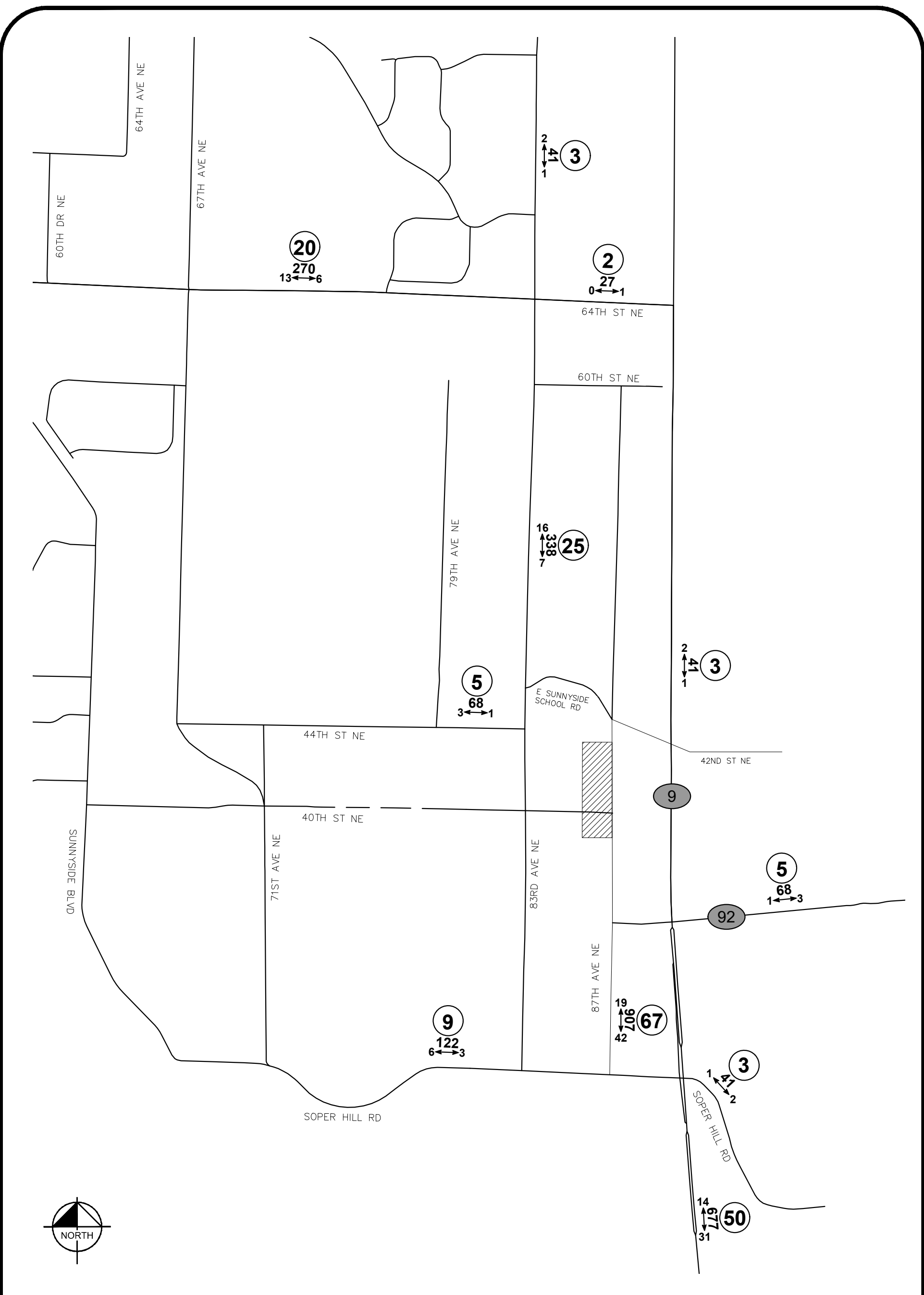

87TH TOWNHOMES

CITY OF MARYSVILLE

LEGEND

AWDT
 AM ↔ PEAK
 (XX)

NEW DAILY TRAFFIC
 NEW AM PEAK-HOUR TRIPS
 TRIP DISTRIBUTION %

FIGURE 2

OPENING YEAR
 TRIP DISTRIBUTION
 AM PEAK-HOUR

Date: February 05, 2023 3:29pm / User: jcoyner
 Path: K:\SWD\PTD\2022\22-013_87th Townhomes\Figures\87th Ave Figures_Connected.dwg / Xref: WSDOT.txd3d

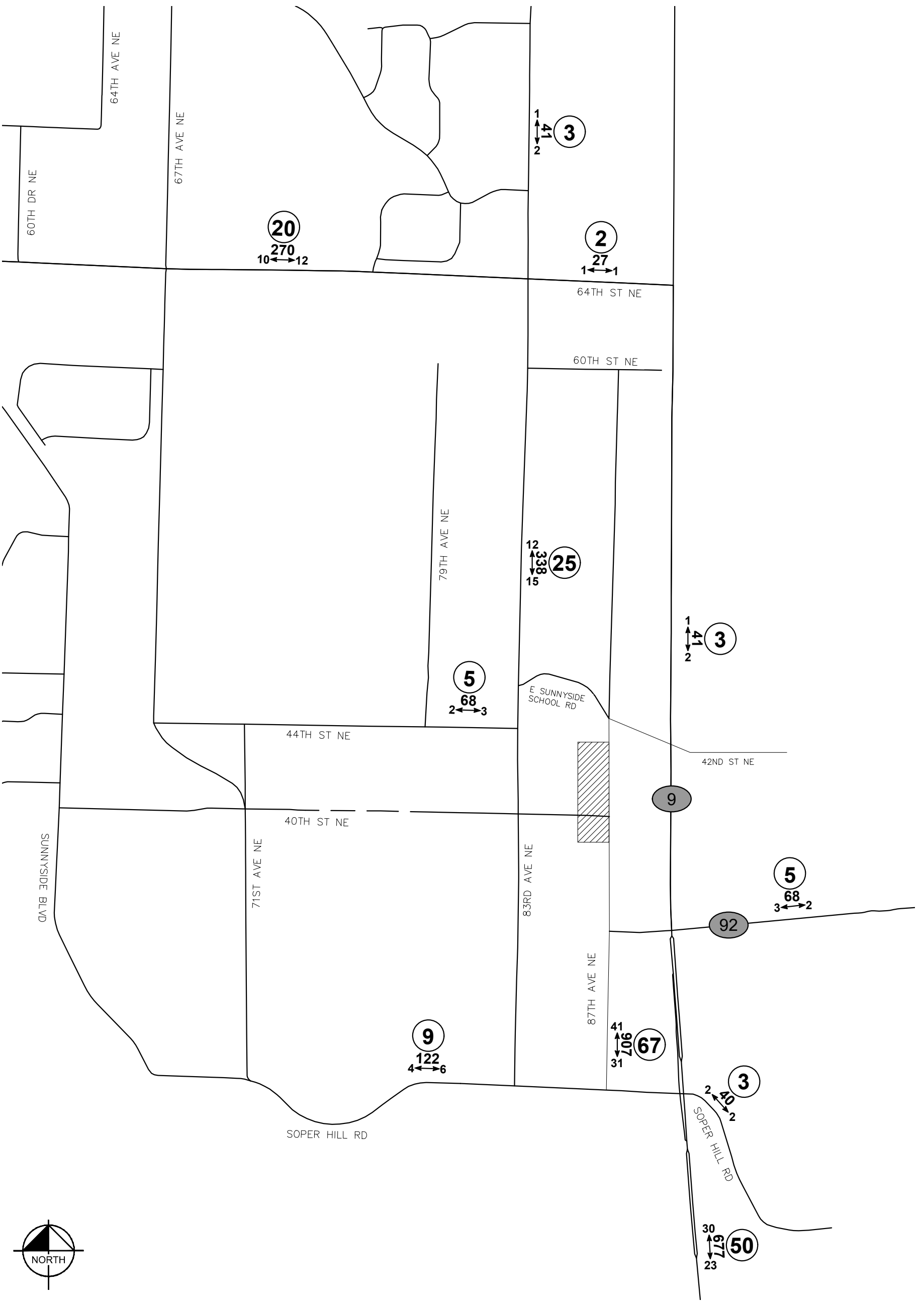

87TH TOWNHOMES

CITY OF MARYSVILLE

LEGEND

AWDT
 PM ← PEAK
 (XX)

NEW DAILY TRAFFIC
 NEW PM PEAK-HOUR TRIPS
 TRIP DISTRIBUTION %

FIGURE 3

OPENING YEAR
 TRIP DISTRIBUTION
 PM PEAK-HOUR

4.2 2031 Horizon Year

The horizon year distribution considers future roadway improvements, particularly the construction of 40th Street NE and the connection between SR-9 and 87th Avenue NE at the intersection with SR-9. It is anticipated that 52% of the trips generated by the development will utilize the access of SR-9 at SR-92. It is estimated that 22% of the trips generated by the development will travel to and from the north along 83rd Avenue NE. Approximately 23% of the trips generated by the development will travel to and from the west, fourteen percent along 40th Street NE and nine percent along Soper Hill Road. The remaining 3% of the trips generated by the development will travel along Soper Hill Road east of SR-9. The horizon year trip distributions for the weekday AM and PM peak-hours are shown in Figure 4 and Figure 5, respectively.

5. INTERSECTION LEVEL OF SERVICE ANALYSIS

The City of Marysville typically requires analysis at intersections impacted with 25 peak-hour trips. Intersection analysis has been performed at the following intersections:

1. 87th Avenue NE at Soper Hill Road – Two-way Stop Control
2. 87th Avenue NE at 40th Street NE – Future Roundabout
3. 87th Avenue NE at E Sunnyside School Road – Two-way Stop Control
4. 83rd Avenue NE at E Sunnyside School Road – Two-way Stop Control
5. SR-528/64th Street NE at 83rd Avenue NE – Signal

The majority of the study intersections have been analyzed for the 2022 existing conditions, the 2025 Opening Year conditions, and the 2031 Horizon Year conditions during the weekday PM peak- hour. The 2031 Horizon Year accounts for a 6-year period beyond the opening date, which is anticipated to occur in 2025. It is important to note that the intersection of SR-528/64th Street NE at 83rd Avenue NE is not impacted with 25 PM peak-hour trips under the 2031 Horizon Year conditions due to the roadway improvements included in the 2031 Horizon Year conditions. The intersection of SR-528/64th Street NE at 83rd Avenue NE has therefore only been analyzed for the 2022 existing and 2025 Opening Year conditions.

Additionally, City of Marysville staff has requested turning movement volumes for trips generated by the development for the following intersections:

6. SR-9 at Soper Hill Road
7. 87th Avenue NE at 35th Street NE/SR-92 Extension
8. 35th Street NE at SR-92

Analysis has not been required at these intersections since they are either WSDOT intersections or are part of the future roadway network that will be constructed in the area. There are planned improvements along Soper Hill Road that include additional channelization at the intersection with SR-9. These improvements are discussed in more detail under the mitigation section.

Date: February 03, 2023 - 4:26pm / User: jcoyner
 Path: K:\SNO_HFD\2022\22-013_87th Townhomes\Figures\87th Ave Figures_Connected.dwg / Xref: WSDOTseed3D

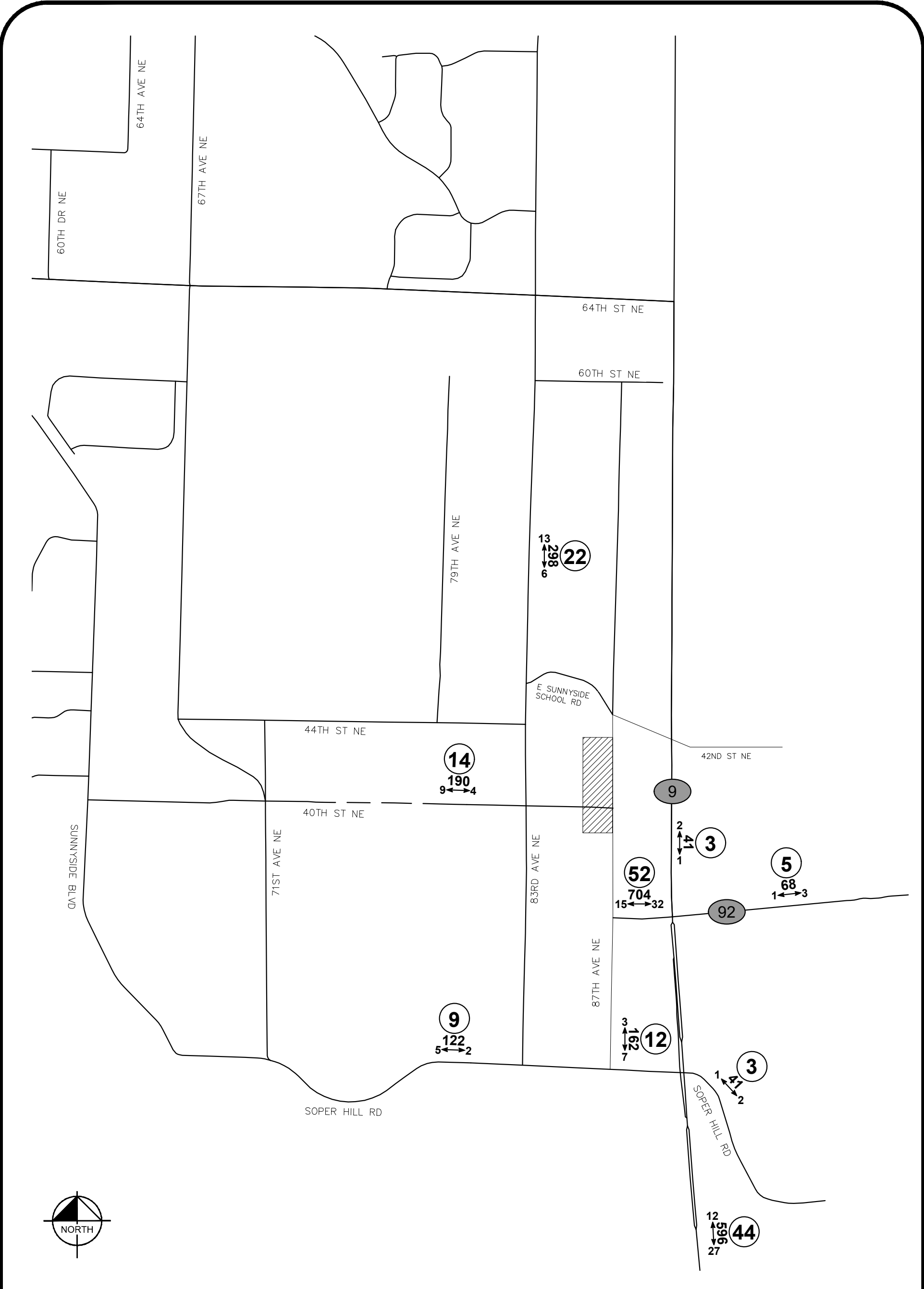

87TH TOWNHOMES

CITY OF MARYSVILLE

LEGEND

AWDT
 AM ← PEAK
 (XX)

NEW DAILY TRAFFIC
 NEW AM PEAK-HOUR TRIPS
 TRIP DISTRIBUTION %

FIGURE 4

HORIZON YEAR
 TRIP DISTRIBUTION
 AM PEAK-HOUR

Date: February 03, 2023 - 4:26pm / User: jcoyner
 Path: K:\SNO_HFD\2022\22-013_87th Townhomes\Figures\87th Ave Figures_Corrected.dwg / Xref: WSDOTseed3D

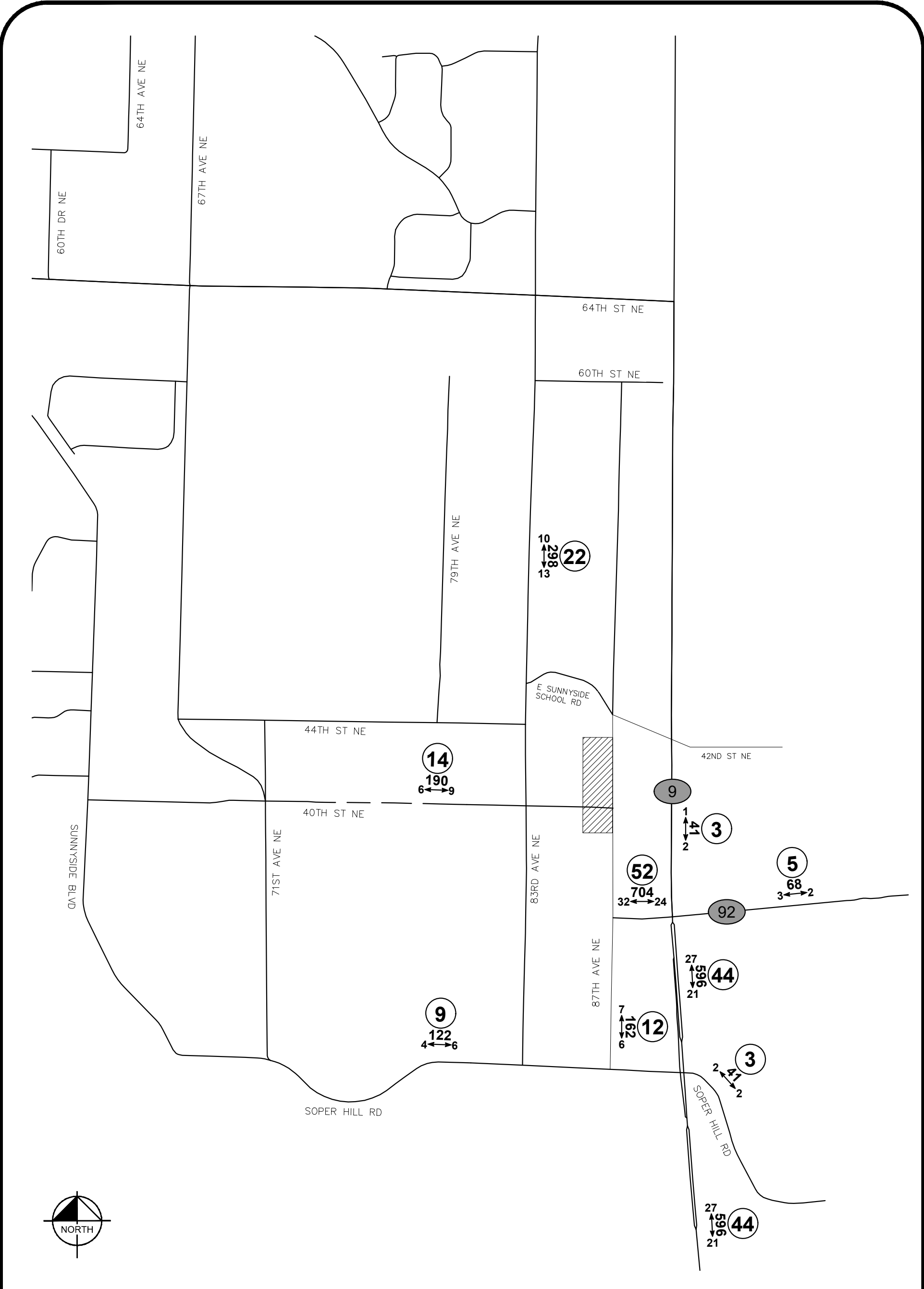

87TH TOWNHOMES

LEGEND

AWDT
 PM ← → PEAK

(XX)

NEW DAILY TRAFFIC
 NEW PM PEAK-HOUR TRIPS
 TRIP DISTRIBUTION %

FIGURE 5

HORIZON YEAR
 TRIP DISTRIBUTION
 PM PEAK-HOUR

CITY OF MARYSVILLE

5.1 Turning Movement Calculations

The existing weekday PM peak-hour (one hour between 4:00 PM and 6:00 PM) turning movements at the study intersections were collected by the independent count firm Traffic Data Gathering (TDG) in August 2022.

The 2025 and 2031 baseline turning movements at the study intersections have been calculated by applying a 3% annually compounding growth rate to the existing turning movements. It is important to note that the 2025 and 2031 volumes for the intersection of 87th Avenue NE at 40th Street NE are based on the 2035 model volumes provided by the City of Marysville since this intersection will be constructed as part of the development. These volumes are overly conservative for the 2025 baseline and 2031 baseline conditions. The 2025 and 2031 future with development turning movements at the study intersections have been calculated by adding the trips generated by the development to the 2025 and 2031 baseline turning movements. The following figures identify the turning movements for each scenario:

- Figure 6: Existing Turning Movements
- Figure 7: 2025 Baseline Turning Movements
- Figure 8: 2025 Opening Year Turning Movements
- Figure 9: 2031 Baseline Turning Movements
- Figure 10: 2031 Horizon Year Turning Movements

The turning movement calculations, including detailed distributions of the trips generated by the development, are shown in the attachments.

5.2 Level of Service Calculations

The level of service calculations have been performed utilizing the existing channelization, existing intersection control, heavy vehicle factors, and peak-hour factors from the turning movement counts. The parameters have been used for the existing, 2025 opening year, and 2031 horizon year conditions. The future roundabout for the intersection of 87th Avenue NE at 40th Street NE has been analyzed as a 1-lane roundabout to represent a conservative approach to the analysis. The full design of the roundabout will be addressed later and could include additional channelization. The intersection level of service analysis for the existing and 2025 opening year conditions is summarized in Table 3.

5	57 51 119	129 448 78
	148 509 105	74 69 77

4	128 45	59 26
		219 9

3	6 1 11	8 8 3
	46 3	15 5 1

1	3 2	18 441
	3 302	

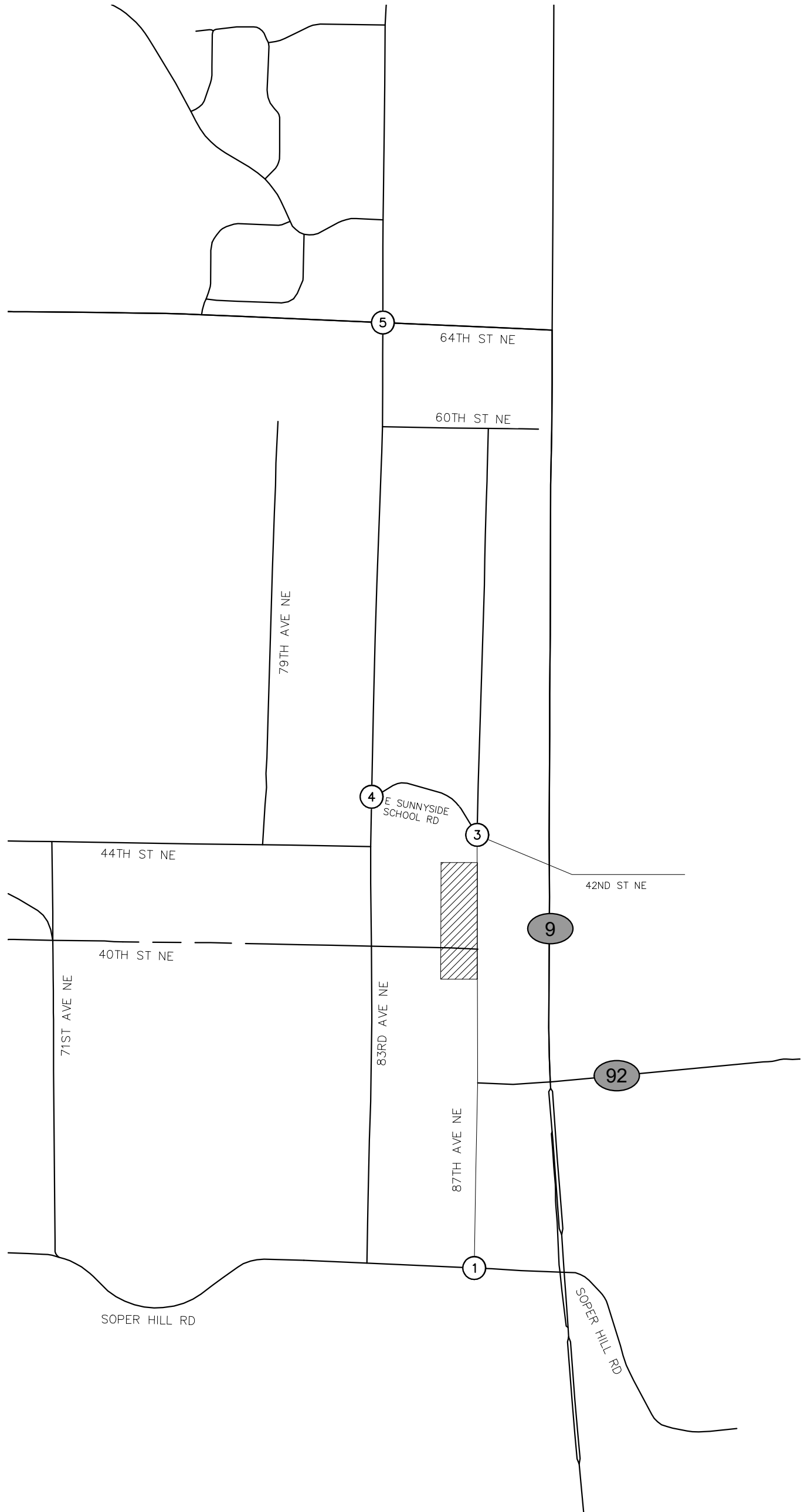
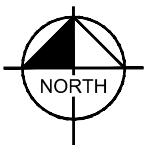

87TH TOWNHOMES

CITY OF MARYSVILLE

LEGEND

- XXX → PEAK-HOUR TURNING MOVEMENT VOLUME
- (XX) STUDY INTERSECTION

FIGURE 6
EXISTING TURNING MOVEMENTS

5	62 56 130	141 490 85
	162 556 115	81 75 84

4	140 49	64 28
		239 10

3	7 1 12	9 66 3
	50 3	16 5 1

1	3 2	20 482
	3 330	

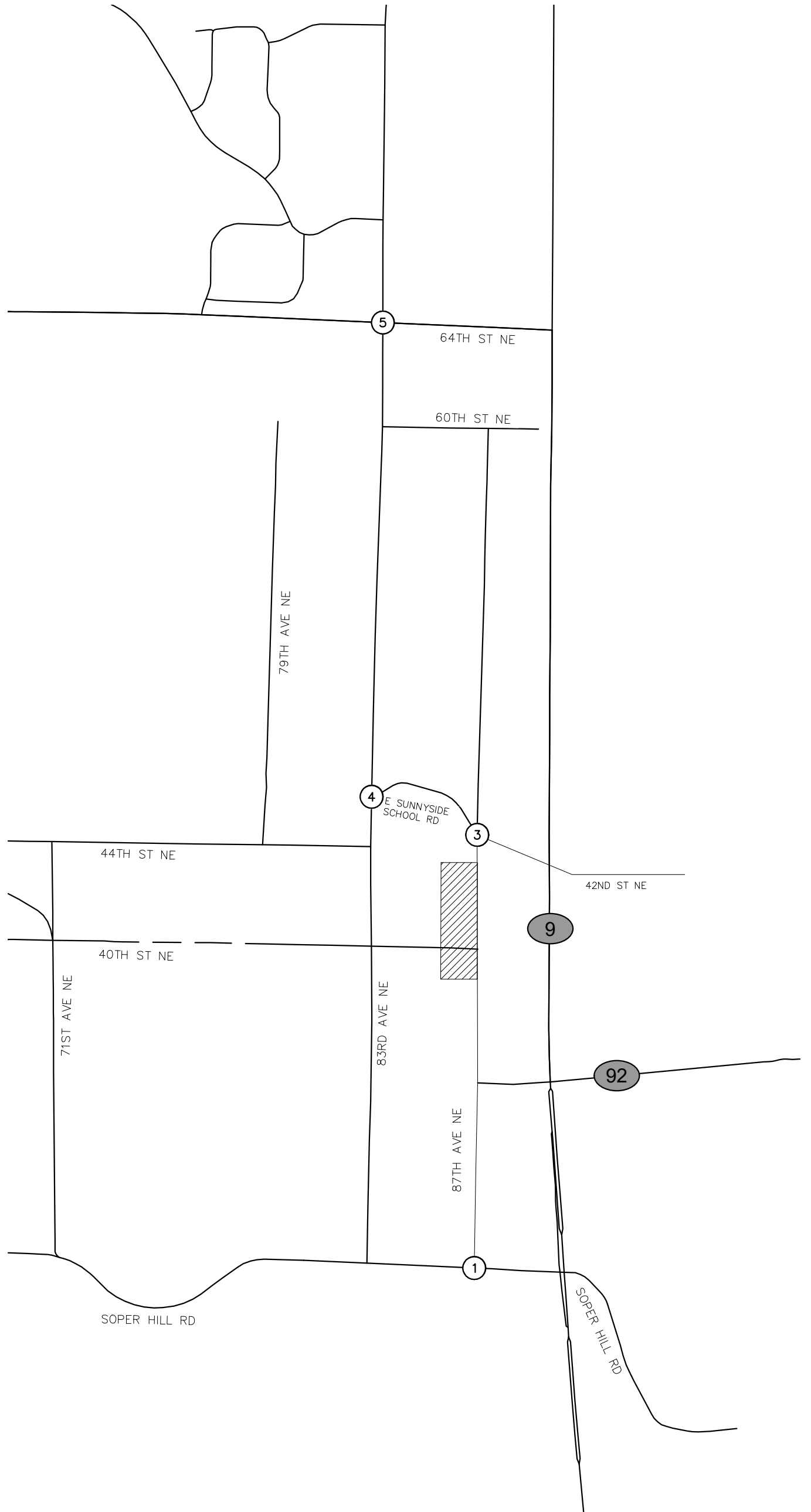

87TH TOWNHOMES

CITY OF MARYSVILLE

LEGEND

- XXX → PEAK-HOUR TURNING MOVEMENT VOLUME
- (XX) STUDY INTERSECTION

FIGURE 7
 2025 BASELINE
 TURNING MOVEMENTS

<p>3 ←</p>	<p>← 2</p>
<p>2 →</p> <p>2 →</p> <p>23 →</p>	<p>30 →</p>

*DEVELOPMENT TRIPS

<p>62 ←</p> <p>58 ←</p> <p>130 ←</p>	<p>141 →</p> <p>490 →</p> <p>86 →</p>
<p>162 →</p> <p>556 →</p> <p>127 →</p>	<p>91 →</p> <p>76 →</p> <p>85 →</p>

<p>140 ←</p> <p>64 ←</p>	<p>76 →</p> <p>30 →</p>
	<p>239 →</p> <p>13 →</p>

<p>7 ←</p> <p>1 ←</p> <p>12 ←</p>	<p>9 →</p> <p>66 →</p> <p>5 →</p>
<p>50 →</p> <p>21 →</p>	<p>30 →</p> <p>5 →</p> <p>2 →</p>

<p>7 ←</p> <p>28 ←</p>	<p>55 →</p> <p>482 →</p>
<p>9 →</p> <p>330 →</p>	

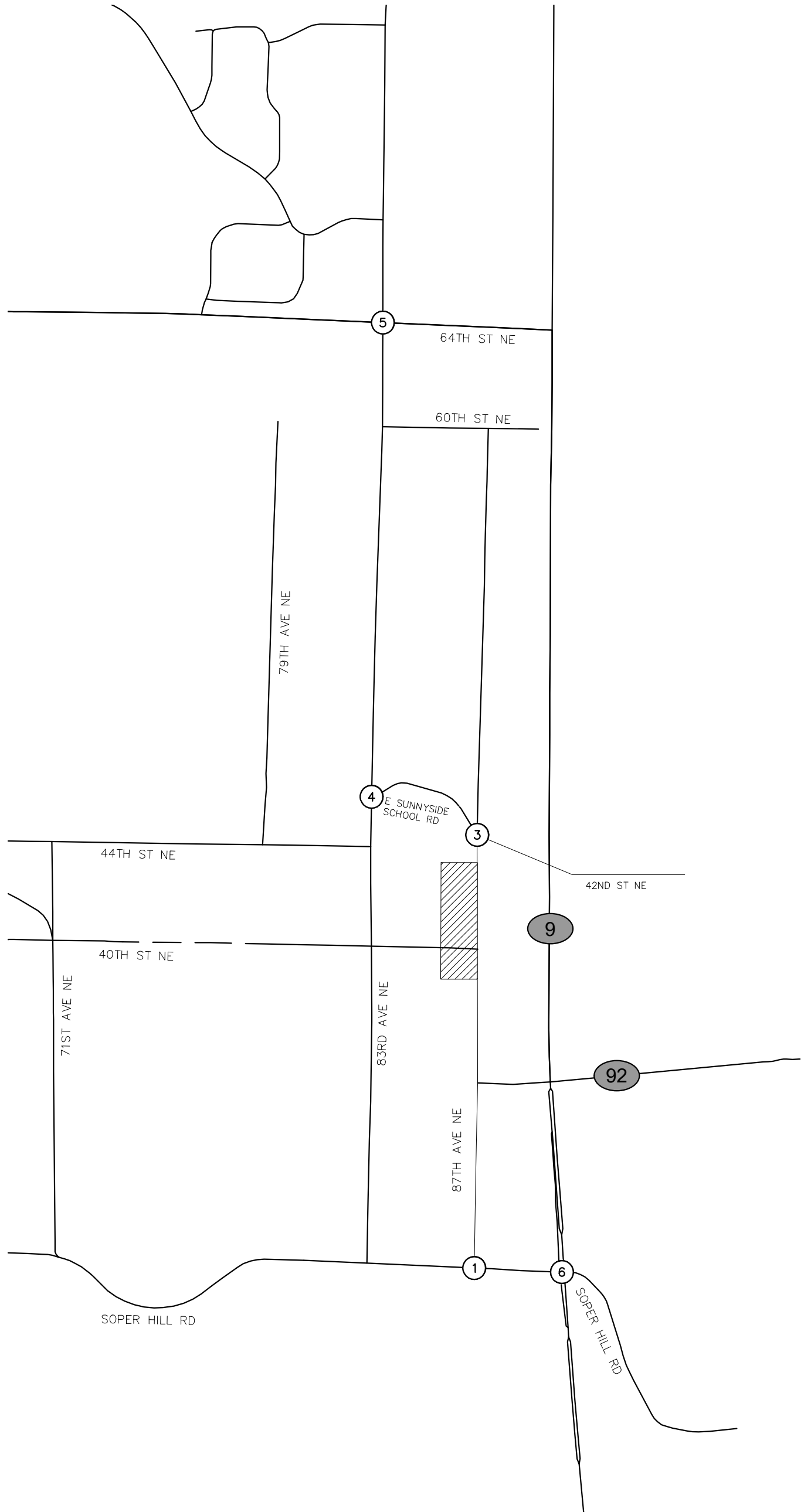
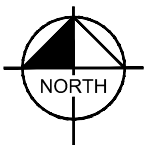

87TH TOWNHOMES

CITY OF MARYSVILLE

LEGEND

- XXX → PEAK-HOUR TURNING MOVEMENT VOLUME
- (XX) STUDY INTERSECTION

FIGURE 8
 2025 OPENING YEAR
 TURNING MOVEMENTS

④	← 167 ↙ 59	↗ 77 ↘ 34	→ 286 ↘ 12
③	↙ 8 ↓ 1 ↘ 14	↗ 10 ↘ 78 ↘ 4	→ 60 ↘ 4 → 20 ↘ 7 ↘ 1
②	↙ 50 ↘ 80	↗ 50 ↘ 560	↗ 595 ↘ 80
①	↙ 4 ↘ 3	↗ 23 ↘ 575	↗ 4 → 394

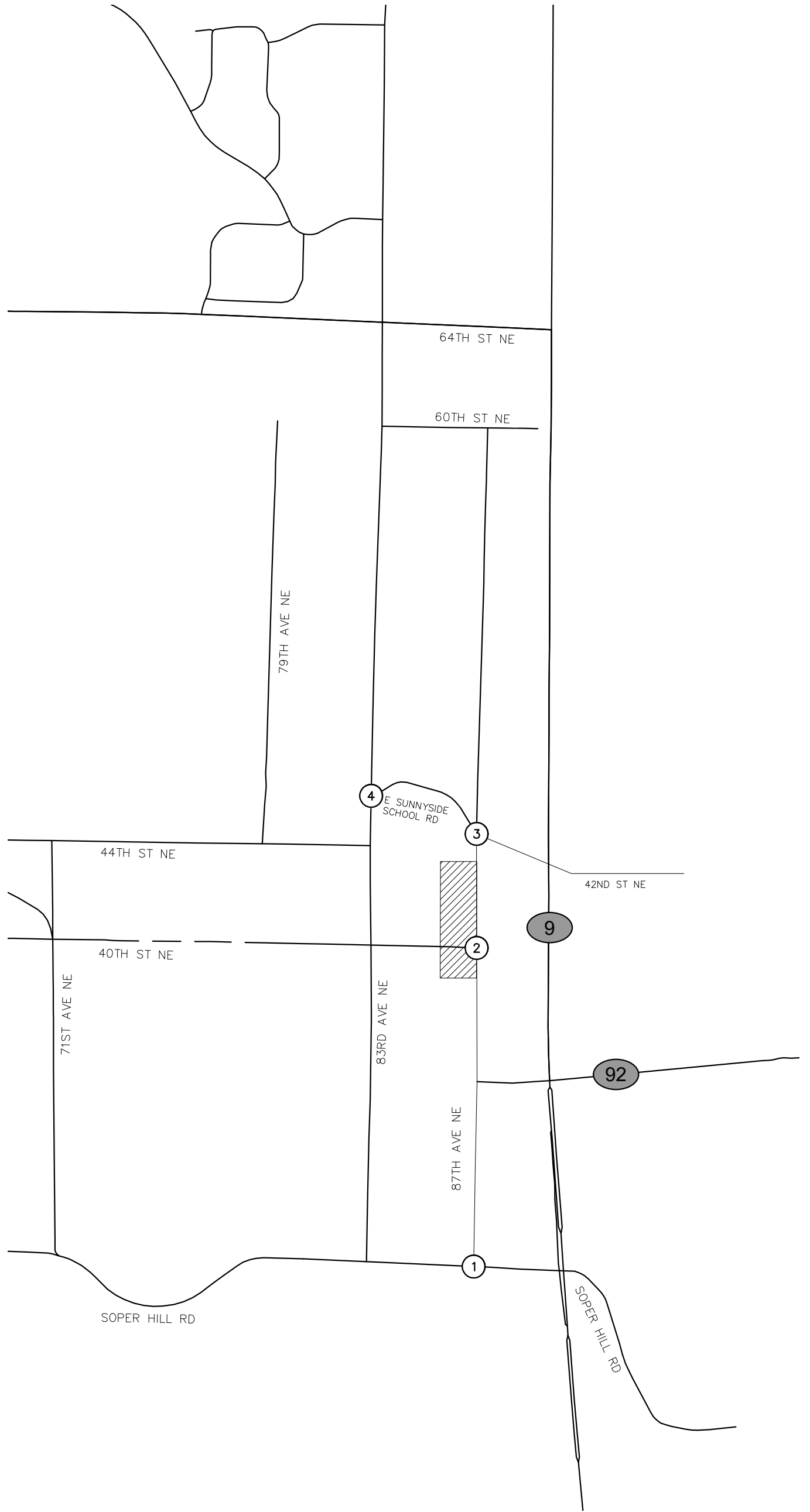
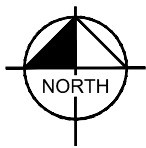

87TH TOWNHOMES

CITY OF MARYSVILLE

LEGEND

- XXX → PEAK-HOUR TURNING MOVEMENT VOLUME
- Ⓧ STUDY INTERSECTION

FIGURE 9
 2031 BASELINE
 TURNING MOVEMENTS

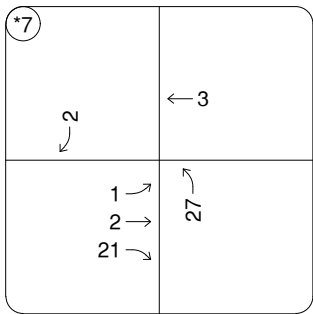

*DEVELOPMENT TRIPS

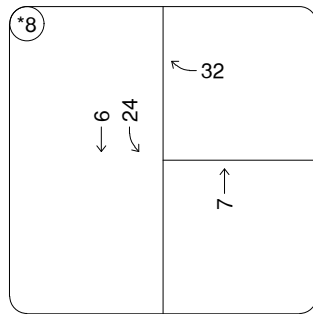

*DEVELOPMENT TRIPS

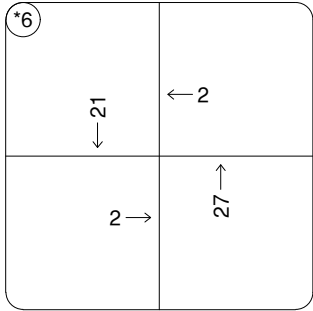

*DEVELOPMENT TRIPS

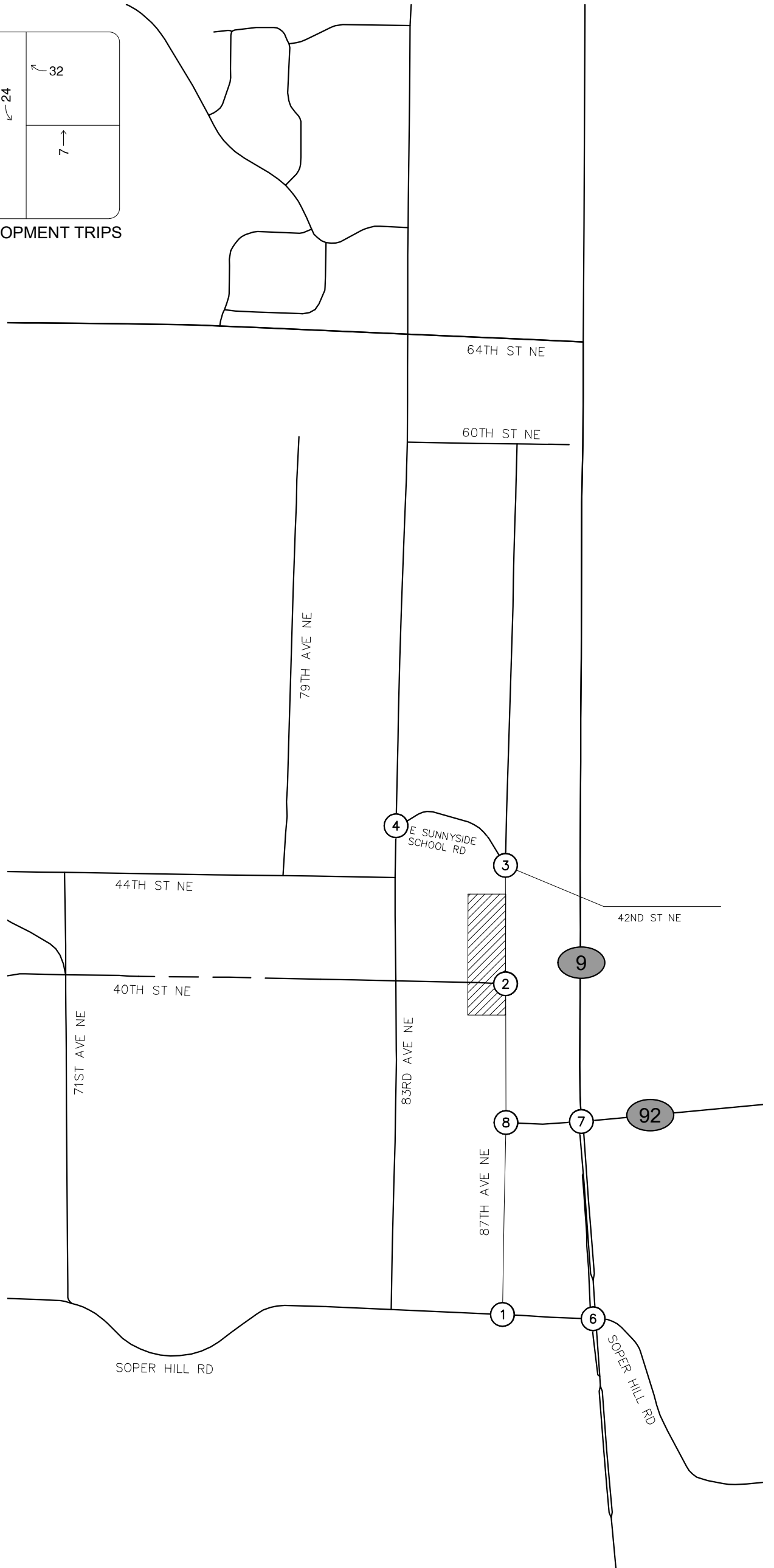
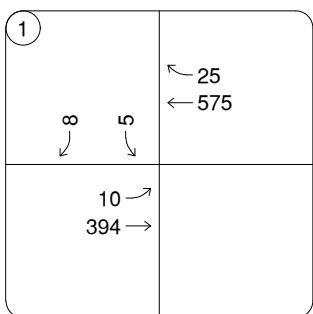
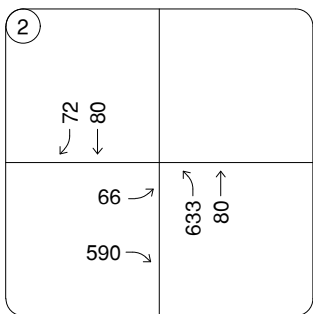
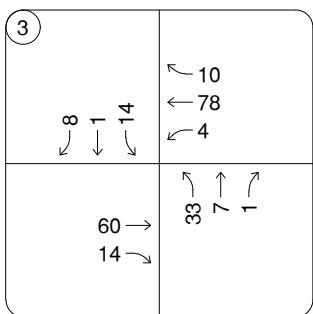
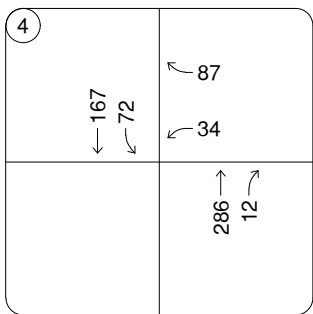

87TH TOWNHOMES

CITY OF MARYSVILLE

LEGEND

- XXX → PEAK-HOUR TURNING MOVEMENT VOLUME
- (XX) STUDY INTERSECTION

FIGURE 10
 2031 HORIZON YEAR
 TURNING MOVEMENTS

Table 3: Level of Service Summary – 2025 Opening Year Conditions

Intersection	Control	2022 Existing Conditions		2025 Baseline Conditions		2025 Opening Year Conditions	
		LOS	Delay	LOS	Delay	LOS	Delay
1. 87 th Avenue NE at Soper Hill Road	Two-Way Stop-Control	B	13.0 sec	B	13.7 sec	C	17.2 sec
2. 83 rd Avenue NE at 40 th Street NE	Roundabout	--	--	A	7.6 sec v/c 0.58	A	7.8 sec v/c 0.63
3. 87 th Avenue NE at E Sunnyside School Road	Two-Way Stop-Control	A	9.6 sec	A	9.7 sec	A	9.8 sec
4. 87 th Avenue NE at E Sunnyside School Road	Two-Way Stop-Control	B	11.5 sec	B	11.5 sec	B	11.7 sec
5. SR-528/64 th Street NE at 83 rd Avenue NE	Signal	B	18.7 sec	C	20.3 sec	C	20.7 sec

The intersection level of service for the existing and 2031 horizon year conditions is summarized in Table 4.

Table 4: Level of Service Summary – 2031 Horizon Year Conditions

Intersection	Control	2022 Existing Conditions		2031 Baseline Conditions		2031 Horizon Year Conditions	
		LOS	Delay	LOS	Delay	LOS	Delay
1. 87 th Avenue NE at Soper Hill Road	Two-Way Stop-Control	B	13.0 sec	C	15.8 sec	C	15.0 sec
2. 83 rd Avenue NE at 40 th Street NE	Roundabout	--	--	A	7.6 sec v/c 0.58	A	7.8 sec v/c 0.63
3. 87 th Avenue NE at E Sunnyside School Road	Two-Way Stop-Control	A	9.6 sec	A	10.0 sec	B	10.1 sec
4. 87 th Avenue NE at E Sunnyside School Road	Two-Way Stop-Control	B	11.5 sec	B	12.6 sec	B	14.8 sec

The level of service analysis shows that the study intersections are all anticipated to operate at acceptable levels of service with the 87th Townhomes development under the 2025 Opening Year and 2031 Horizon Year conditions. The level of service calculations are included in the attachments.

6. ACCESS ANALYSIS

The 87th Townhomes development has frontage along 87th Avenue NE and the future 40th Street NE alignment. The frontage improvements are planned to allow for future 5-lane sections along 87th Avenue NE south of 40th Street NE and along the future 40th Street NE alignment. The frontage improvements along 87th Avenue NE north of 40th Street NE will provide for a future 3-lane section. These frontage improvements should provide adequate channelization at the access locations and allow for full access, particularly at the 40th Street NE. The 52 units along the south side of 40th Avenue NE only have access via the proposed access location. Analysis for the year 2035 shows that the access is anticipated to operate at LOS B and the access should have adequate sight distance and spacing with the new roadway construction.

7. TRAFFIC MITIGATION FEES

The City of Marysville has an interlocal agreement with Snohomish County that provides for the payment of traffic mitigation fees to Snohomish County for City of Marysville developments. The City of Marysville also has an understanding with WSDOT for the payment of traffic mitigation fees.

7.1 City of Marysville

The City of Marysville traffic mitigation fees have been calculated using the residential rate of \$6,300 per PM peak-hour trip. The 87th Townhomes development is proposed to generate 107.76 PM peak-hour trips. These trips will result in traffic mitigation fees of \$678,699.00. These fees do not include a credit for frontage improvements, including the roundabout for the intersection of 87th Avenue NE at 40th Street NE. It is possible that the frontage improvements are creditable to the traffic mitigation fee and are in excess of the traffic mitigation fee. If this is the case, the City of Marysville traffic mitigation fee should not be required for the 87th Townhomes development.

7.2 City of Lake Stevens

The City of Marysville and the City of Lake Stevens have an interlocal agreement to fund improvements to Soper Hill Road from SR-9 to 83rd Avenue NE. Construction of new roundabouts at 83rd Avenue NE and 87th Avenue NE and additional channelization along Soper Hill Road between 87th Avenue NE and SR-9 are located in the City of Lake Stevens and identified in the interlocal agreement. Construction of the 83rd Avenue NE roundabout is complete. The 87th Townhomes development will not trigger the intersection of 87th Avenue NE at Soper Hill Road to operate below LOS D. The 87th Townhomes development should therefore only be conditioned to the fee for the intersection.

The intersection of 87th Avenue NE at Soper Hill Road has a fee of \$1,700.00 per PM peak-hour trip impacting the intersection. The trip distribution shows that the intersection of 87th Avenue NE at Soper Hill Road will be impacted by 10 PM peak-hour trips. The fee for impacts to the intersection of 87th Avenue NE at Soper Hill Road should therefore be \$17,000.00. It should be noted that the fee should not be a condition if the 87th Avenue NE roundabout is constructed prior to when these fees would be due. Additionally, the fee will be paid to the City of Marysville according to the interlocal agreement if the fee is required to be paid.

7.3 Snohomish County

The City of Marysville and Snohomish County have an interlocal agreement that provides for the payment of traffic mitigation for impacts to Snohomish County roadways by City of Marysville developments. Traffic mitigation fees are based on predetermined area impacts or impacts to actual improvement projects. The nearest Snohomish County improvement project on their *Transportation Needs Report (TNR)* is located along 88th Street NE west of 67th Avenue NE. The City of Marysville trip distributions, included with this TIA, show that only 3% of the trips generated by the development are anticipated to travel along 88th Street NE. This would result in less than 2 directional peak-hour trips along this roadway. Section 3(a) of the *Snohomish County Traffic Worksheet and Traffic Study Requirements for Development in the City of Marysville* identifies a threshold of 3 directional PM peak-hour trips. This threshold is not anticipated to be met and therefore a Snohomish County traffic mitigation fee should not be a condition of the 87th Townhomes development.

7.4 Washington State Department of Transportation

There are two major WSDOT improvements in the site vicinity that are impacted by trips generated by the 87th Townhomes development. These improvements are the 40th Street NE corridor improvements and the SR-92 improvement. Both of these improvements are identified as funded as part of the Connecting Washington legislation. Payment of WSDOT traffic mitigation fees should therefore not be a condition of the 87th Townhomes development.

8. CONCLUSIONS

The 87th Townhomes development is proposed to consist of 189 single-family attached residential units. The development could generate up to approximately 1,361 average weekday daily trips with 91 weekday AM peak-hour trips and 108 weekday PM peak-hour trips. There are five intersections that are impacted and are shown to operate at acceptable levels during the weekday PM peak-hour. The total traffic mitigation fees for the development could be up to \$604,044.00 for the City of Marysville without any credit for roadway improvements that will be completed as part of the development. WSDOT and Snohomish County traffic mitigation fees should not be required for the 87th Townhomes development.

City of Marysville Trip Distributions

WHISKEY RIDGE WEST - HORIZON

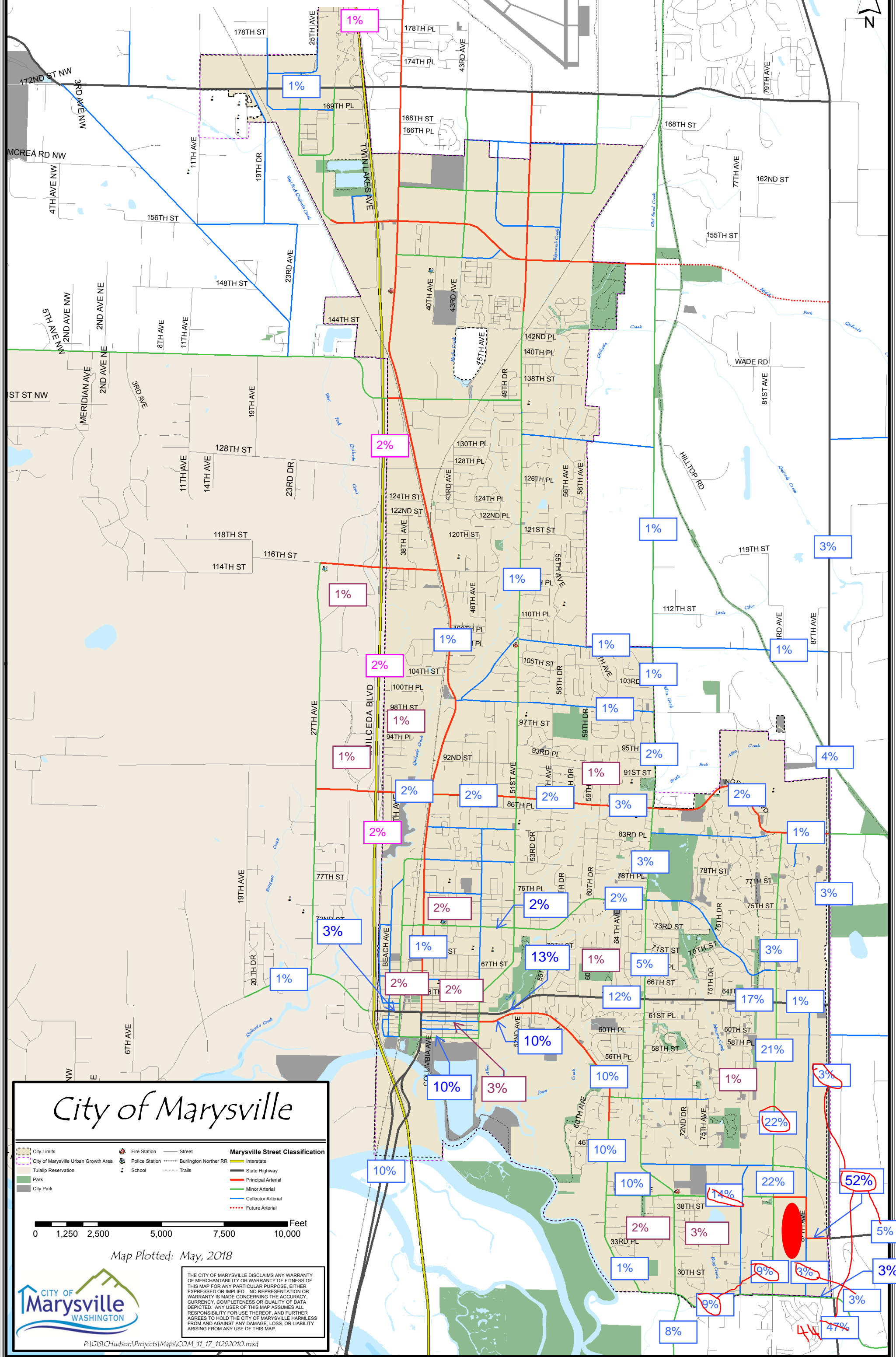

City of Marysville

			Marysville Street Classification

0 1,250 2,500 5,000 7,500 10,000 Feet

Map Plotted: May, 2018

CITY OF Marysville WASHINGTON

THE CITY OF MARYSVILLE DISCLAIMS ANY WARRANTY OF MERCHANTABILITY OR WARRANTY OF FITNESS OF THIS MAP FOR ANY PARTICULAR PURPOSE, EITHER EXPRESSED OR IMPLIED. NO REPRESENTATION OR WARRANTY IS MADE CONCERNING THE ACCURACY, CURRENCY, COMPLETENESS OR QUALITY OF DATA DEPICTED. ANY USER OF THIS MAP ASSUMES ALL RESPONSIBILITY FOR USE THEREOF, AND FURTHER AGREES TO HOLD THE CITY OF MARYSVILLE HARMLESS FROM AND AGAINST ANY DAMAGE, LOSS, OR LIABILITY ARISING FROM ANY USE OF THIS MAP.

P:\GIS\Hudson\Projects\Maps\COM_11_17_11292010.mxd

Count Data

87th Avenue NE @ E Sunnyside School Road Marysville, WA

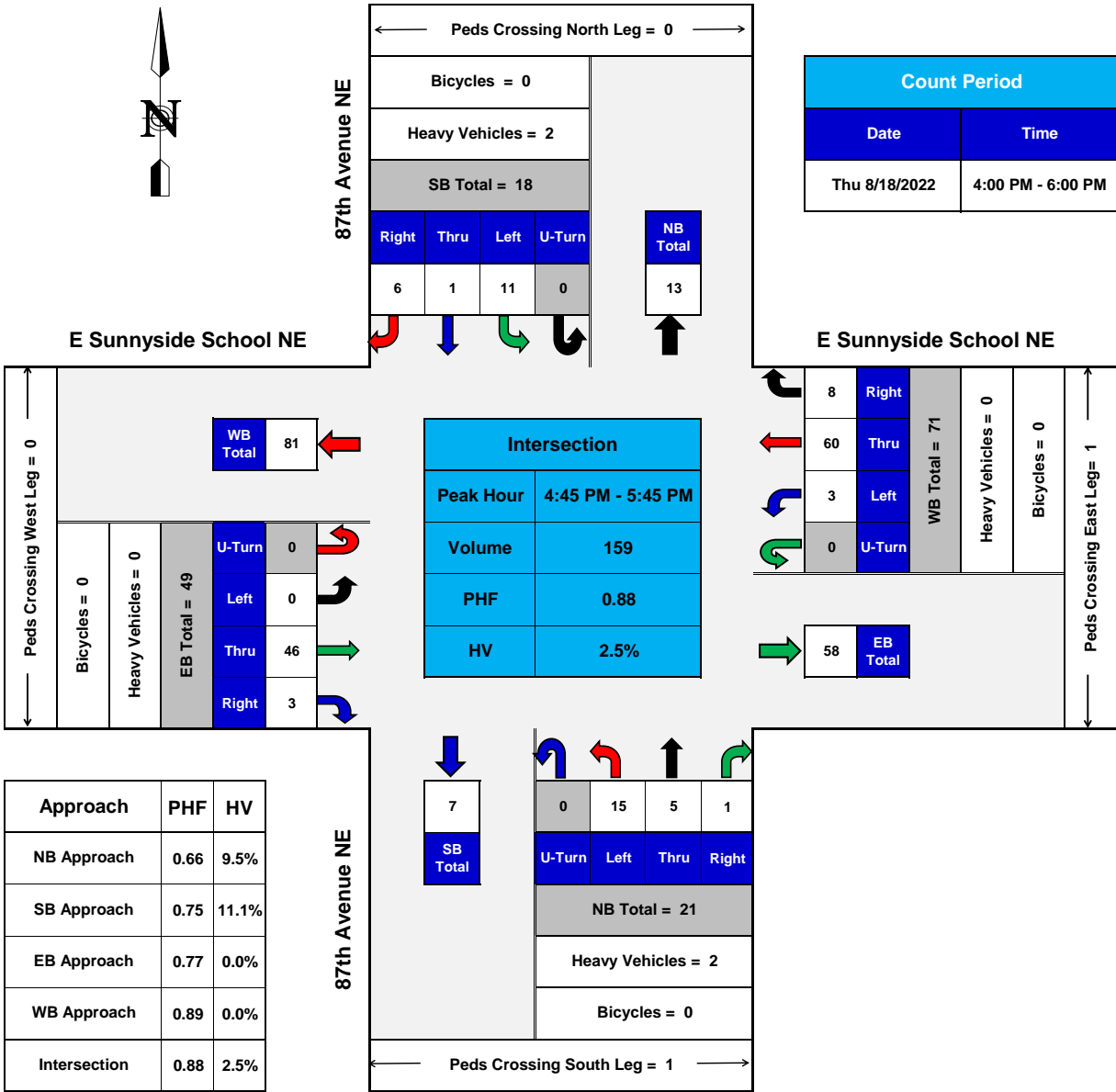

PHF = Peak Hour Factor
HV = Heavy Vehicles

TURNING MOVEMENTS DIAGRAM PEAK HOUR SUMMARY



83rd Avenue NE @ E Sunnyside School Road

Marysville, WA

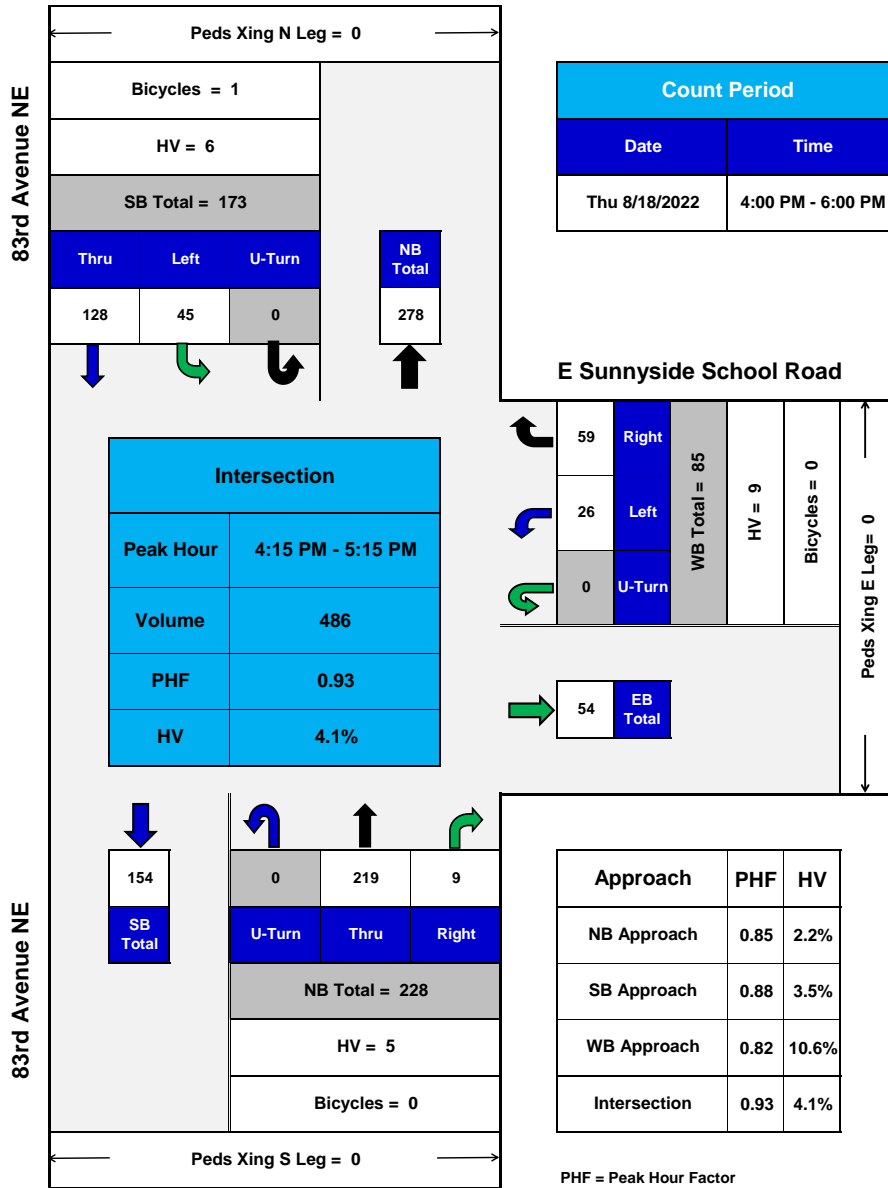

TURNING MOVEMENTS DIAGRAM PEAK HOUR SUMMARY



SR-528 (64th Street NE) @ 83rd Avenue NE

Marysville, WA

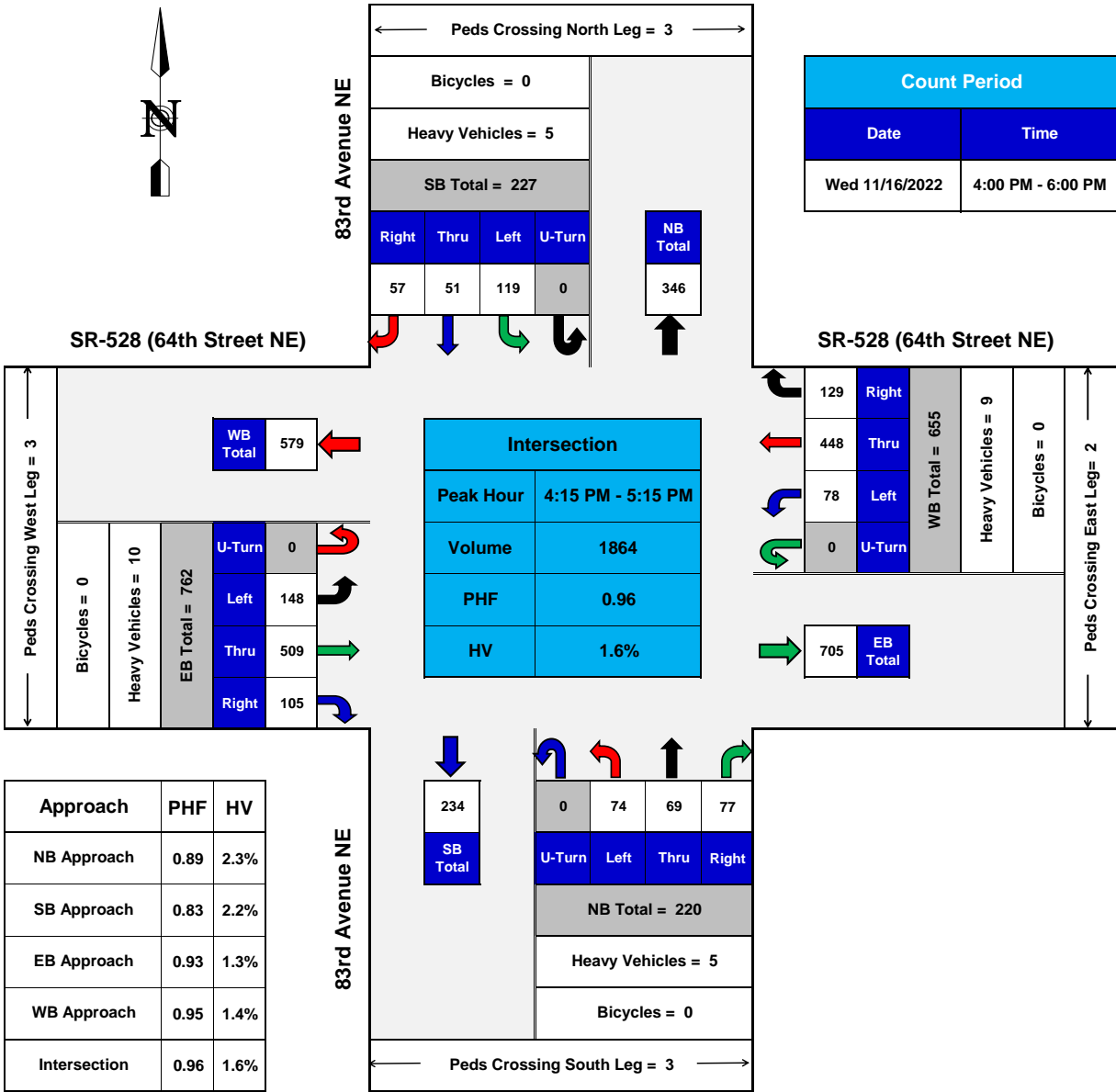

PHF = Peak Hour Factor
 HV = Heavy Vehicles

TURNING MOVEMENTS DIAGRAM PEAK HOUR SUMMARY



Turning Movement Calculations

Synchro ID: 1

Existing
Average Weekday
PM Peak-Hour

Year: 8/18/2022

Data Source: TDG

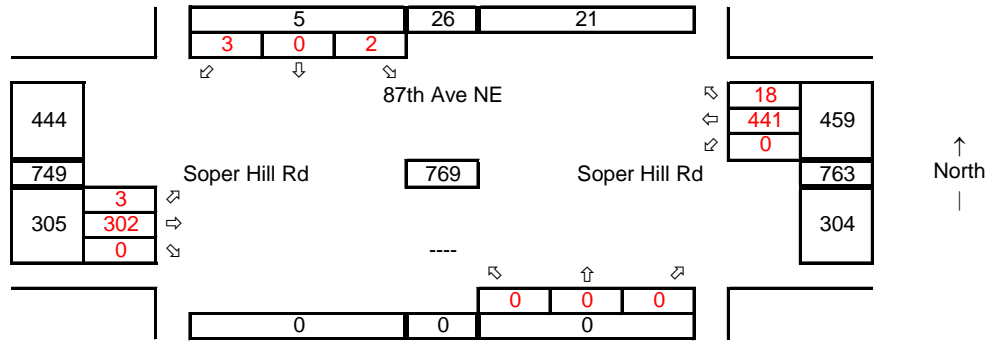

Future without Development

Average Weekday
PM Peak Hour

Year: 2025

Growth Rate = 3.0%

Years of Growth = 3

Total Growth = 1.0927

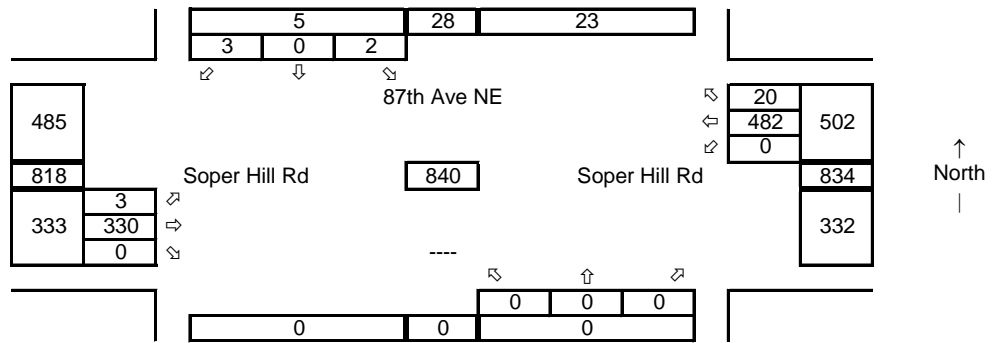

Total Development Trips

Average Weekday
PM Peak Hour

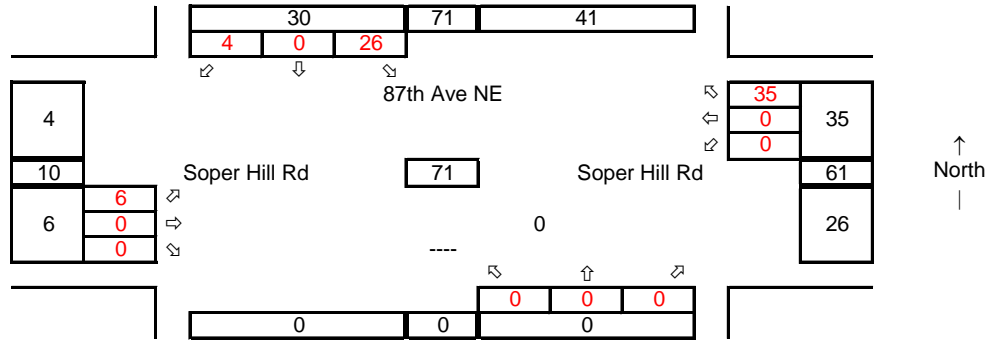

Future with Development

Average Weekday
PM Peak Hour

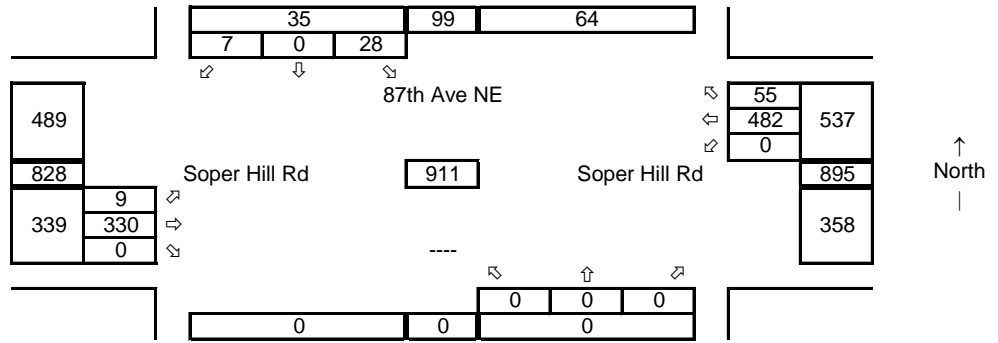

Synchro ID: 3
Existing
 Average Weekday
 PM Peak-Hour

Year: 8/18/2022

Data Source: TDG

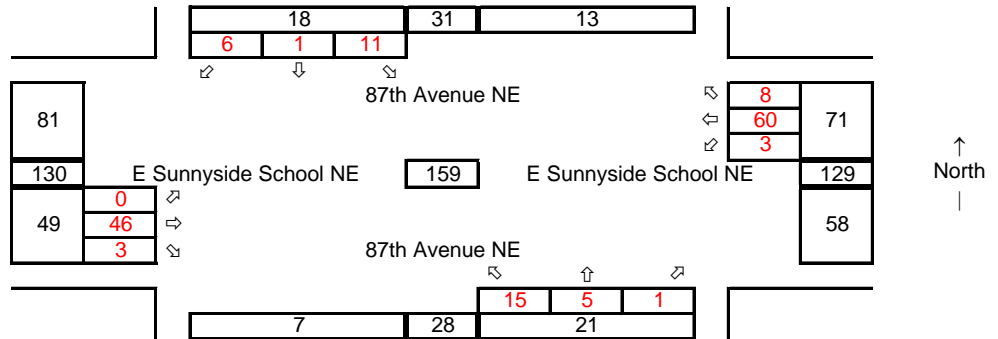

Future without Development
 Average Weekday
 PM Peak Hour

Year: 2025
 Growth Rate = 3.0%
 Years of Growth = 3
 Total Growth = 1.0927

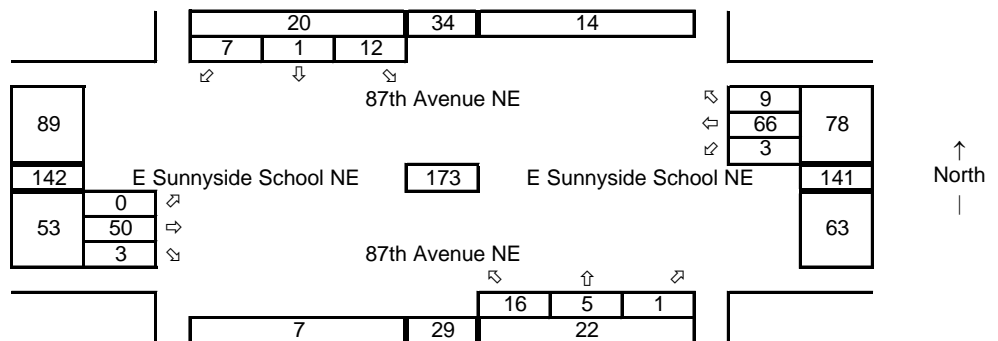

Total Development Trips
 Average Weekday
 PM Peak Hour

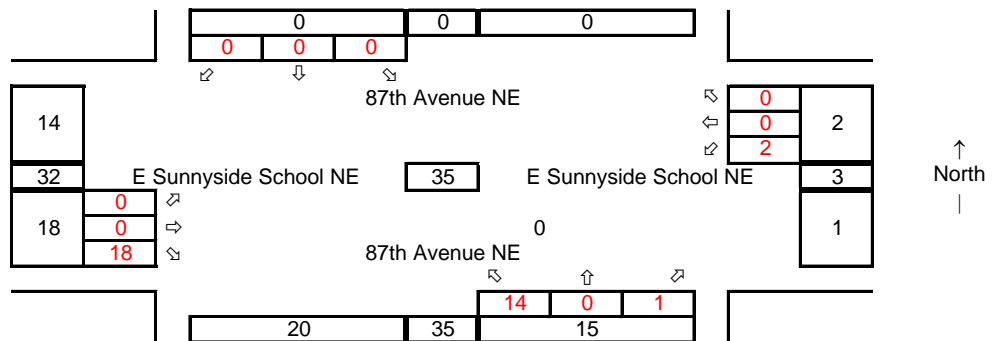

Future with Development
 Average Weekday
 PM Peak Hour

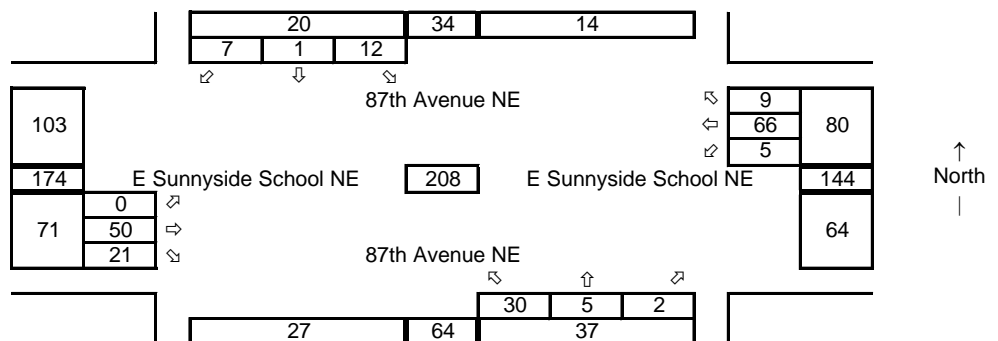

Opening Year

5 SR-528-64th St at 83rd Ave

Weekday PM Peak-Hour

Synchro ID: 5

Existing

Average Weekday
PM Peak-Hour

Year: **11/16/2022**

Data Source: **TDG**

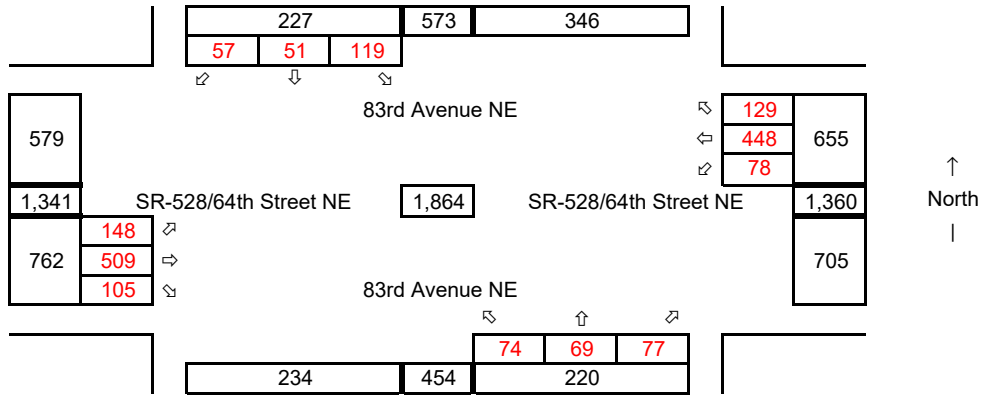

Future without Development

Average Weekday
PM Peak Hour

Year: 2025

Growth Rate = 3.0%

Years of Growth = 3

Total Growth = 1.0927

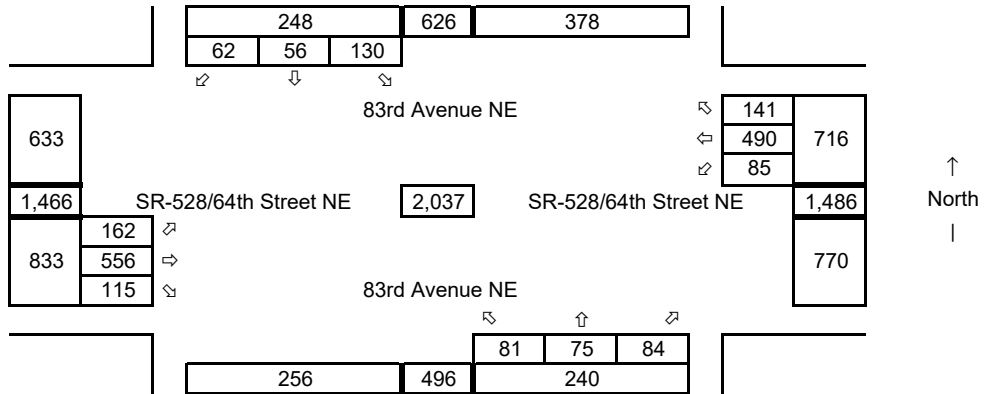

Total Development Trips

Average Weekday
PM Peak Hour

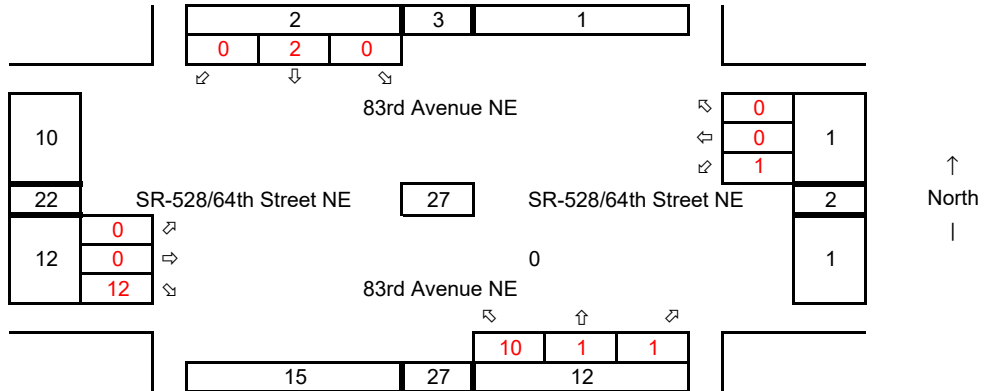

Future with Development

Average Weekday
PM Peak Hour

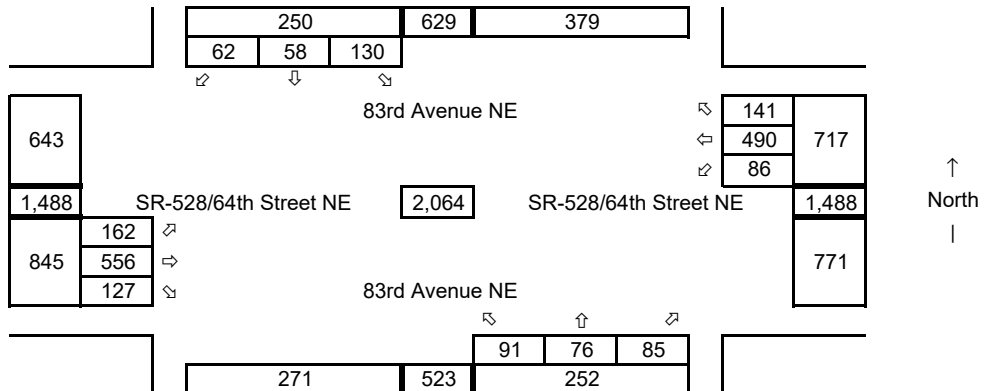

Synchro ID: 1
Existing
 Average Weekday
 PM Peak-Hour

Year: 8/18/2022

Data Source: TDG

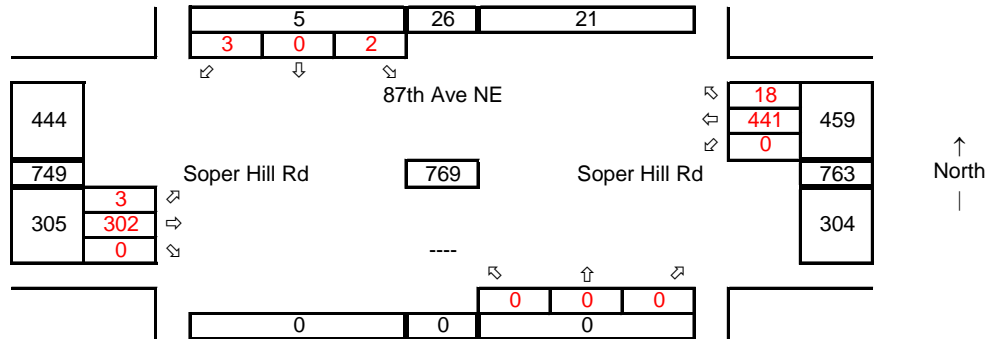

Future without Development
 Average Weekday
 PM Peak Hour

Year: 2031
 Growth Rate = 3.0%
 Years of Growth = 9
 Total Growth = 1.3048

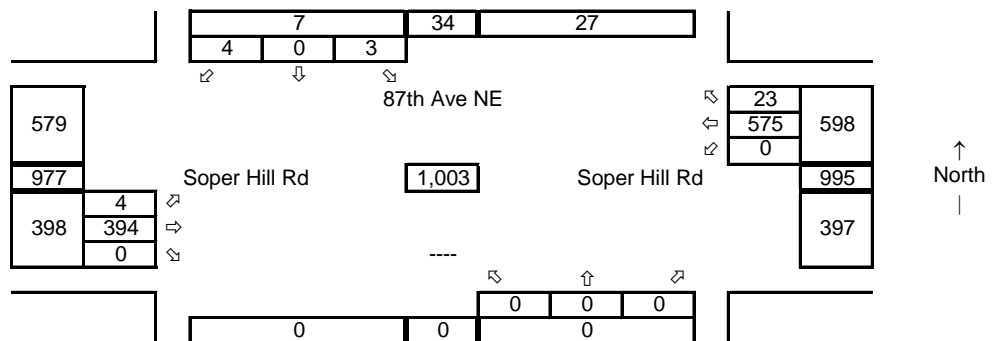

Total Development Trips
 Average Weekday
 PM Peak Hour

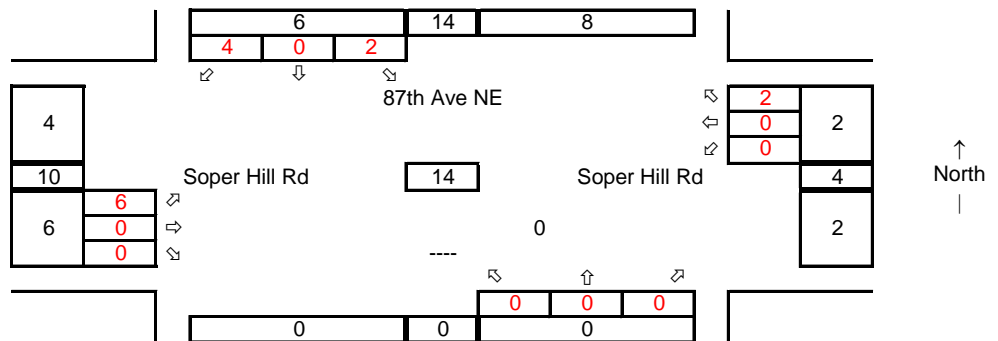

Future with Development
 Average Weekday
 PM Peak Hour

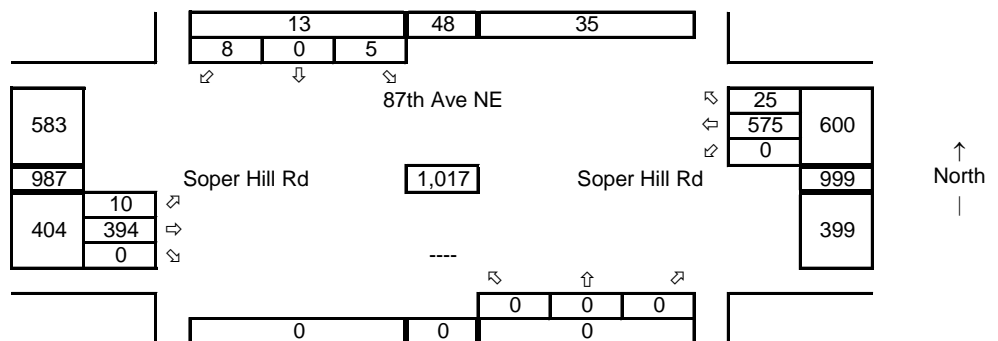

Synchro ID: 2
Existing
 Average Weekday
 PM Peak-Hour

Year: 1/1/2022

Data Source: CoM

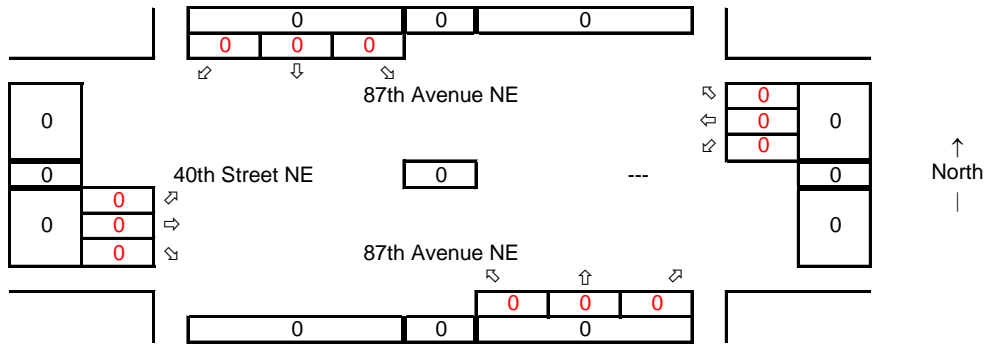

Baseline

Average Weekday
 PM Peak-Hour

Year: 2035

Growth Rate = 0.0%

Years of Growth = 13

Total Growth = 1.0000

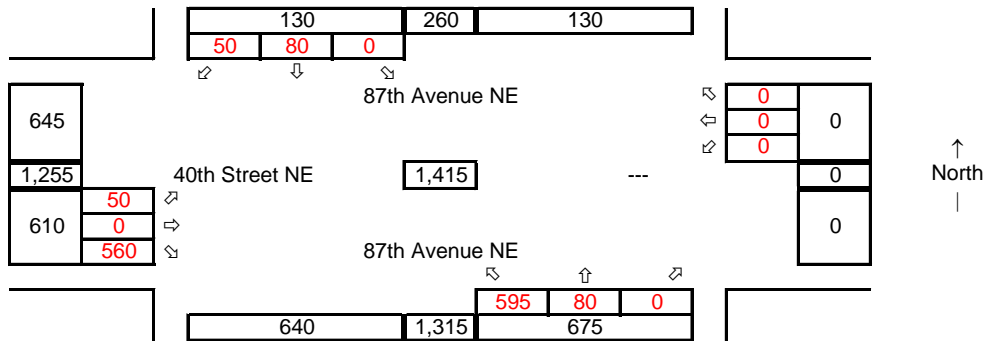

Development

Average Weekday
 PM Peak-Hour

Based on Opening Year
 development trips since that
 is the highest volume

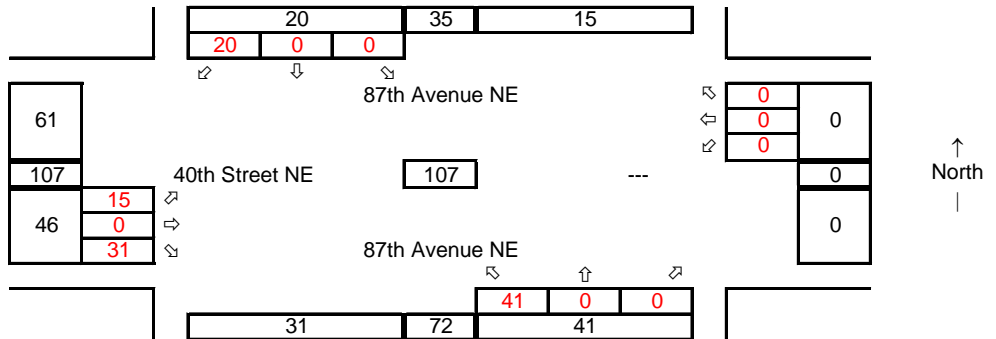

Future w Development

Average Weekday
 PM Peak-Hour

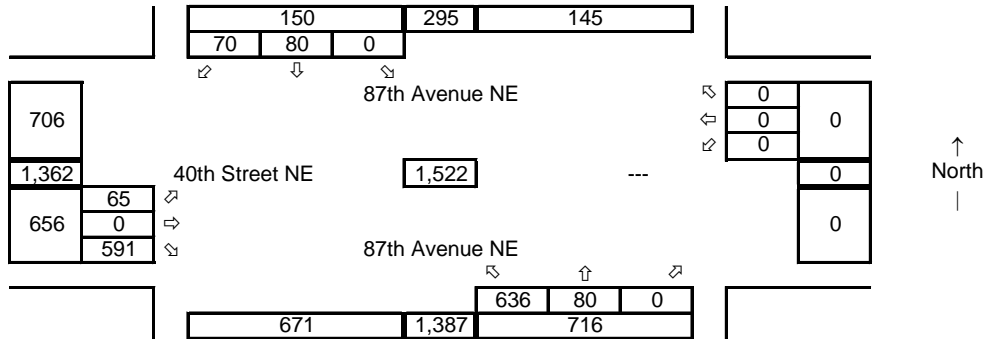

Synchro ID: 3
Existing
 Average Weekday
 PM Peak-Hour

Year: 8/18/2022

Data Source: TDG

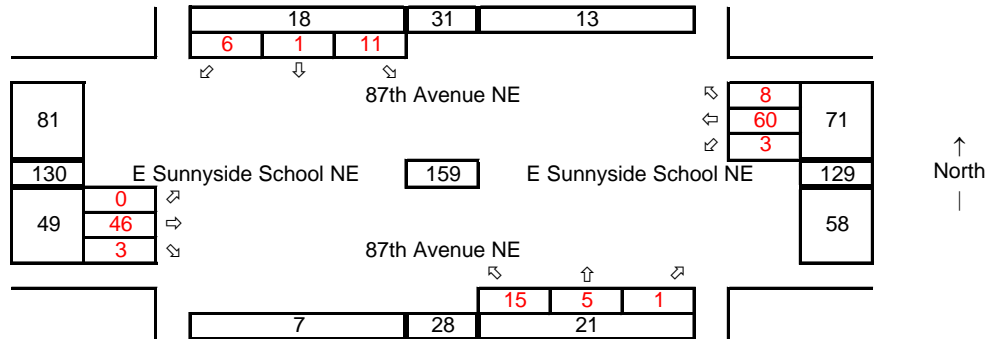

Future without Development
 Average Weekday
 PM Peak Hour

Year: 2031
 Growth Rate = 3.0%
 Years of Growth = 9
 Total Growth = 1.3048

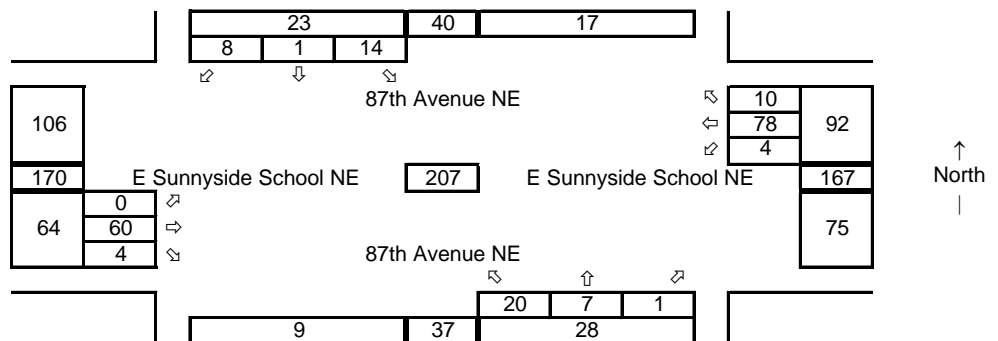

Total Development Trips
 Average Weekday
 PM Peak Hour

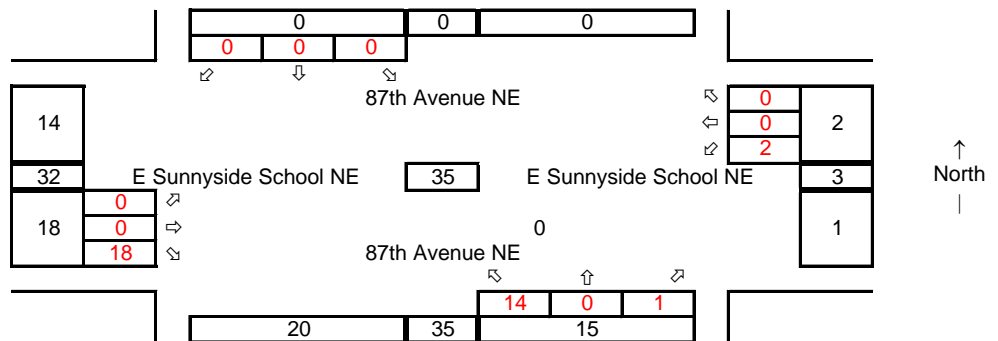

Future with Development
 Average Weekday
 PM Peak Hour

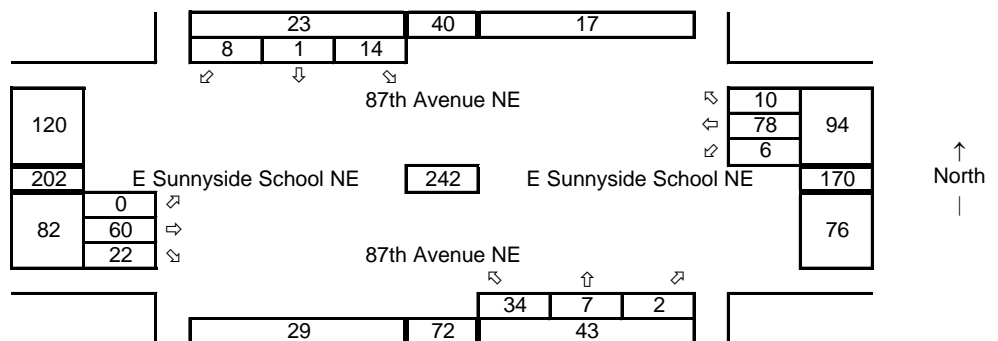

Synchro ID: 4
Existing
 Average Weekday
 PM Peak-Hour

Year: 8/18/2022

Data Source: TDG

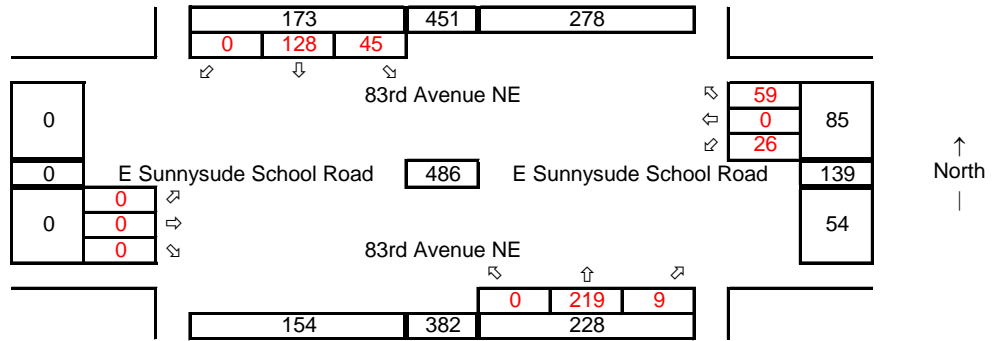

Future without Development
 Average Weekday
 PM Peak Hour

Year: 2031
 Growth Rate = 3.0%
 Years of Growth = 9
 Total Growth = 1.3048

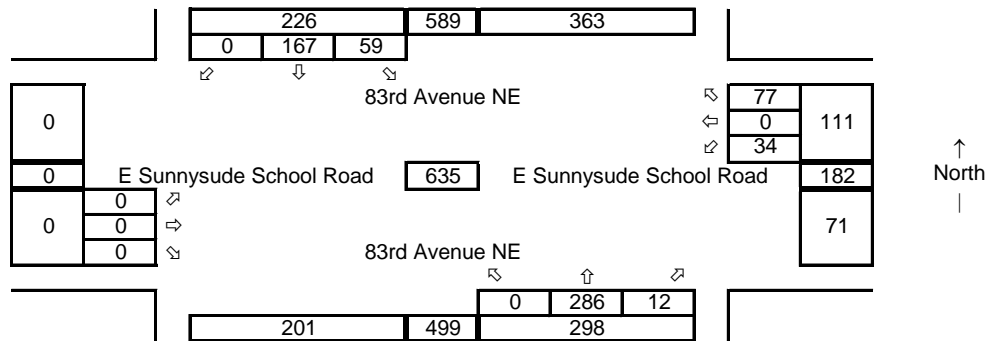

Total Development Trips
 Average Weekday
 PM Peak Hour

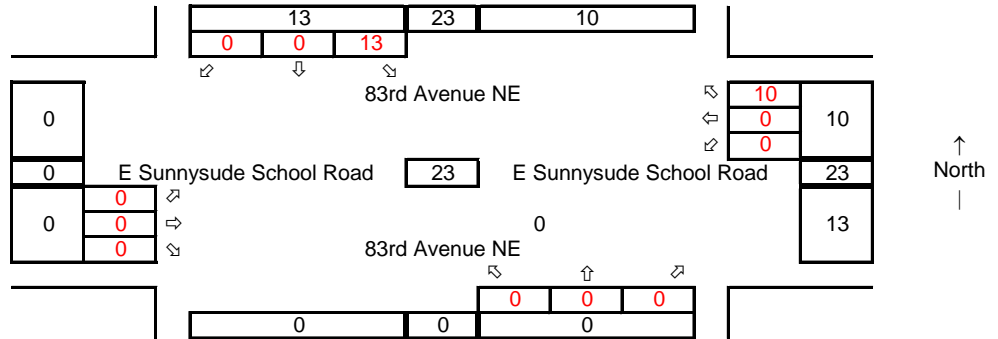

Future with Development
 Average Weekday
 PM Peak Hour

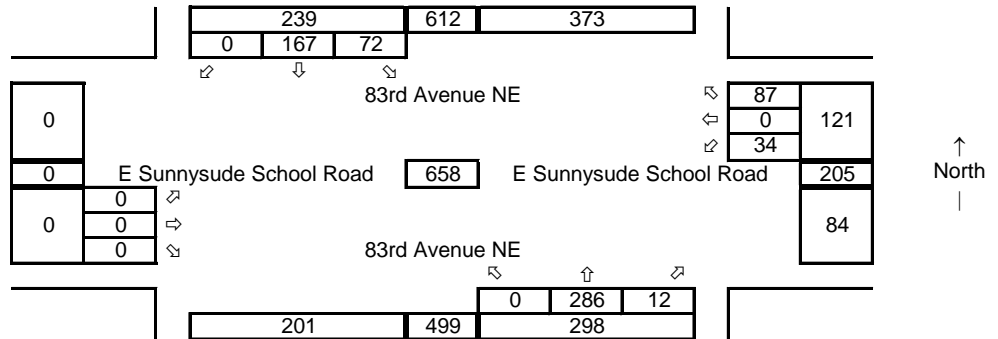

Level of Service Calculations

Intersection						
Int Delay, s/veh	0.1					
Movement	EBL	EBT	WBT	WBR	SBL	SBR
Lane Configurations		↕	↕		↕	
Traffic Vol, veh/h	3	302	441	18	2	3
Future Vol, veh/h	3	302	441	18	2	3
Conflicting Peds, #/hr	0	0	0	0	0	0
Sign Control	Free	Free	Free	Free	Stop	Stop
RT Channelized	-	None	-	None	-	None
Storage Length	-	-	-	-	0	-
Veh in Median Storage, #	-	0	0	-	0	-
Grade, %	-	0	0	-	0	-
Peak Hour Factor	93	93	93	93	93	92
Heavy Vehicles, %	3	3	3	3	3	3
Mvmt Flow	3	325	474	19	2	3

Major/Minor	Major1	Major2	Minor2		
Conflicting Flow All	493	0	0	815	484
Stage 1	-	-	-	484	-
Stage 2	-	-	-	331	-
Critical Hdwy	4.13	-	-	6.43	6.23
Critical Hdwy Stg 1	-	-	-	5.43	-
Critical Hdwy Stg 2	-	-	-	5.43	-
Follow-up Hdwy	2.227	-	-	3.527	3.327
Pot Cap-1 Maneuver	1065	-	-	346	581
Stage 1	-	-	-	618	-
Stage 2	-	-	-	725	-
Platoon blocked, %	-	-	-	-	-
Mov Cap-1 Maneuver	1065	-	-	345	581
Mov Cap-2 Maneuver	-	-	-	345	-
Stage 1	-	-	-	616	-
Stage 2	-	-	-	725	-

Approach	EB	WB	SB
HCM Control Delay, s	0.1	0	13
HCM LOS			B

Minor Lane/Major Mvmt	EBL	EBT	WBT	WBR	SBLn1
Capacity (veh/h)	1065	-	-	-	457
HCM Lane V/C Ratio	0.003	-	-	-	0.012
HCM Control Delay (s)	8.4	0	-	-	13
HCM Lane LOS	A	A	-	-	B
HCM 95th %tile Q(veh)	0	-	-	-	0

Intersection												
Int Delay, s/veh	2.4											
Movement	EBL	EBT	EBR	WBL	WBT	WBR	NBL	NBT	NBR	SBL	SBT	SBR
Lane Configurations		↕			↕			↕			↕	
Traffic Vol, veh/h	0	46	3	3	60	8	15	5	1	11	1	6
Future Vol, veh/h	0	46	3	3	60	8	15	5	1	11	1	6
Conflicting Peds, #/hr	0	0	0	0	0	0	0	0	0	0	0	0
Sign Control	Free	Free	Free	Free	Free	Free	Stop	Stop	Stop	Stop	Stop	Stop
RT Channelized	-	-	None	-	-	None	-	-	None	-	-	None
Storage Length	-	-	-	-	-	-	-	-	-	-	-	-
Veh in Median Storage, #	-	0	-	-	0	-	-	0	-	-	0	-
Grade, %	-	0	-	-	0	-	-	0	-	-	0	-
Peak Hour Factor	88	88	88	88	88	88	88	88	88	88	88	88
Heavy Vehicles, %	3	3	3	3	3	3	3	3	3	3	3	2
Mvmt Flow	0	52	3	3	68	9	17	6	1	13	1	7

Major/Minor	Major1			Major2			Minor1			Minor2		
Conflicting Flow All	77	0	0	55	0	0	137	137	54	136	134	73
Stage 1	-	-	-	-	-	-	54	54	-	79	79	-
Stage 2	-	-	-	-	-	-	83	83	-	57	55	-
Critical Hdwy	4.13	-	-	4.13	-	-	7.13	6.53	6.23	7.13	6.53	6.22
Critical Hdwy Stg 1	-	-	-	-	-	-	6.13	5.53	-	6.13	5.53	-
Critical Hdwy Stg 2	-	-	-	-	-	-	6.13	5.53	-	6.13	5.53	-
Follow-up Hdwy	2.227	-	-	2.227	-	-	3.527	4.027	3.327	3.527	4.027	3.318
Pot Cap-1 Maneuver	1515	-	-	1544	-	-	832	752	1010	833	755	989
Stage 1	-	-	-	-	-	-	956	848	-	927	827	-
Stage 2	-	-	-	-	-	-	923	824	-	952	847	-
Platoon blocked, %	-	-	-	-	-	-	-	-	-	-	-	-
Mov Cap-1 Maneuver	1515	-	-	1544	-	-	824	750	1010	826	753	989
Mov Cap-2 Maneuver	-	-	-	-	-	-	824	750	-	826	753	-
Stage 1	-	-	-	-	-	-	956	848	-	927	825	-
Stage 2	-	-	-	-	-	-	914	822	-	945	847	-

Approach	EB			WB			NB			SB		
HCM Control Delay, s	0			0.3			9.6			9.2		
HCM LOS							A			A		

Minor Lane/Major Mvmt	NBLn1	EBL	EBT	EBR	WBL	WBT	WBR	SBLn1
Capacity (veh/h)	812	1515	-	-	1544	-	-	869
HCM Lane V/C Ratio	0.029	-	-	-	0.002	-	-	0.024
HCM Control Delay (s)	9.6	0	-	-	7.3	0	-	9.2
HCM Lane LOS	A	A	-	-	A	A	-	A
HCM 95th %tile Q(veh)	0.1	0	-	-	0	-	-	0.1

Intersection						
Int Delay, s/veh	2.8					
Movement	WBL	WBR	NBT	NBR	SBL	SBT
Lane Configurations						
Traffic Vol, veh/h	26	59	219	9	45	128
Future Vol, veh/h	26	59	219	9	45	128
Conflicting Peds, #/hr	0	0	0	0	0	0
Sign Control	Stop	Stop	Free	Free	Free	Free
RT Channelized	-	None	-	None	-	None
Storage Length	0	-	-	-	-	-
Veh in Median Storage, #	0	-	0	-	-	0
Grade, %	0	-	0	-	-	0
Peak Hour Factor	84	84	84	84	84	84
Heavy Vehicles, %	3	3	5	5	4	4
Mvmt Flow	31	70	261	11	54	152

Major/Minor	Minor1	Major1	Major2			
Conflicting Flow All	527	267	0	0	272	0
Stage 1	267	-	-	-	-	-
Stage 2	260	-	-	-	-	-
Critical Hdwy	6.43	6.23	-	-	4.14	-
Critical Hdwy Stg 1	5.43	-	-	-	-	-
Critical Hdwy Stg 2	5.43	-	-	-	-	-
Follow-up Hdwy	3.527	3.327	-	-	2.236	-
Pot Cap-1 Maneuver	510	769	-	-	1280	-
Stage 1	775	-	-	-	-	-
Stage 2	781	-	-	-	-	-
Platoon blocked, %			-	-		-
Mov Cap-1 Maneuver	487	769	-	-	1280	-
Mov Cap-2 Maneuver	487	-	-	-	-	-
Stage 1	775	-	-	-	-	-
Stage 2	745	-	-	-	-	-

Approach	WB	NB	SB
HCM Control Delay, s	11.5	0	2.1
HCM LOS	B		

Minor Lane/Major Mvmt	NBT	NBRWBLn1	SBL	SBT
Capacity (veh/h)	-	-	653	1280
HCM Lane V/C Ratio	-	-	0.155	0.042
HCM Control Delay (s)	-	-	11.5	7.9
HCM Lane LOS	-	-	B	A
HCM 95th %tile Q(veh)	-	-	0.5	0.1

Lanes, Volumes, Timings
5: 83rd Ave NE & SR-528

87th Townhomes



Lane Group	EBL	EBT	EBR	WBL	WBT	WBR	NBL	NBT	NBR	SBL	SBT	SBR
Lane Configurations												
Traffic Volume (vph)	148	509	105	78	448	129	74	69	77	119	51	57
Future Volume (vph)	148	509	105	78	448	129	74	69	77	119	51	57
Ideal Flow (vphpl)	1900	1900	1900	1900	1900	1900	1900	1900	1900	1900	1900	1900
Storage Length (ft)	250		0	180		160	0		30	0		150
Storage Lanes	1		1	1		1	0		1	0		1
Taper Length (ft)	25			25			25			25		
Lane Util. Factor	1.00	1.00	1.00	1.00	0.95	0.95	1.00	1.00	1.00	1.00	1.00	1.00
Ped Bike Factor	0.99				0.99							0.99
Frt			0.850		0.967				0.850			0.850
Flt Protected	0.950			0.950				0.975			0.966	
Satd. Flow (prot)	1770	1863	1583	1770	3394	0	0	1816	1583	0	1799	1583
Flt Permitted	0.330			0.343				0.765			0.695	
Satd. Flow (perm)	611	1863	1583	639	3394	0	0	1425	1583	0	1295	1563
Right Turn on Red			Yes			Yes			Yes			Yes
Satd. Flow (RTOR)			109		47				98			98
Link Speed (mph)		30			30			30			30	
Link Distance (ft)		3167			1315			3856			1264	
Travel Time (s)		72.0			29.9			87.6			28.7	
Confl. Peds. (#/hr)	5					5						
Confl. Bikes (#/hr)												1
Peak Hour Factor	0.96	0.96	0.96	0.96	0.96	0.96	0.96	0.96	0.96	0.96	0.96	0.96
Shared Lane Traffic (%)												
Lane Group Flow (vph)	154	530	109	81	601	0	0	149	80	0	177	59
Turn Type	pm+pt	NA	Perm	pm+pt	NA		Perm	NA	Perm	Perm	NA	Perm
Protected Phases	5	2		1	6			8			4	
Permitted Phases	2		2	6			8		8	4		4
Detector Phase	5	2	2	1	6		8	8	8	4	4	4
Switch Phase												
Minimum Initial (s)	4.0	5.0	5.0	5.0	7.0		4.0	4.0	4.0	4.0	4.0	4.0
Minimum Split (s)	9.0	19.0	19.0	11.0	20.0		27.5	27.5	27.5	26.0	26.0	26.0
Total Split (s)	15.0	50.0	50.0	15.0	50.0		35.0	35.0	35.0	35.0	35.0	35.0
Total Split (%)	15.0%	50.0%	50.0%	15.0%	50.0%		35.0%	35.0%	35.0%	35.0%	35.0%	35.0%
Yellow Time (s)	4.0	4.0	4.0	5.0	5.0		3.5	3.5	3.5	4.0	4.0	4.0
All-Red Time (s)	1.0	1.0	1.0	1.0	1.0		1.0	1.0	1.0	1.0	1.0	1.0
Lost Time Adjust (s)	0.0	0.0	0.0	0.0	0.0			0.0	0.0		0.0	0.0
Total Lost Time (s)	5.0	5.0	5.0	6.0	6.0			4.5	4.5		5.0	5.0
Lead/Lag	Lead	Lag	Lag	Lead	Lag							
Lead-Lag Optimize?												
Recall Mode	None	None	None	None	None		None	None	None	None	None	None
Act Effct Green (s)	38.2	30.8	30.8	30.5	24.2			17.3	17.3		16.8	16.8
Actuated g/C Ratio	0.56	0.45	0.45	0.45	0.36			0.26	0.26		0.25	0.25
v/c Ratio	0.30	0.63	0.14	0.21	0.48			0.41	0.17		0.55	0.13
Control Delay	8.6	20.2	3.7	8.9	16.8			26.9	4.9		31.5	2.4
Queue Delay	0.0	0.0	0.0	0.0	0.0			0.0	0.0		0.0	0.0
Total Delay	8.6	20.2	3.7	8.9	16.8			26.9	4.9		31.5	2.4
LOS	A	C	A	A	B			C	A		C	A
Approach Delay		15.7			15.9			19.2			24.2	
Approach LOS		B			B			B			C	

Lanes, Volumes, Timings
5: 83rd Ave NE & SR-528

87th Townhomes



Lane Group	EBL	EBT	EBR	WBL	WBT	WBR	NBL	NBT	NBR	SBL	SBT	SBR
Queue Length 50th (ft)	23	164	0	12	86			48	0		59	0
Queue Length 95th (ft)	66	350	28	39	161			128	24		156	11
Internal Link Dist (ft)		3087			1235			3776			1184	
Turn Bay Length (ft)	250			180					30			150
Base Capacity (vph)	530	1322	1155	479	2370			685	812		612	791
Starvation Cap Reductn	0	0	0	0	0			0	0		0	0
Spillback Cap Reductn	0	0	0	0	0			0	0		0	0
Storage Cap Reductn	0	0	0	0	0			0	0		0	0
Reduced v/c Ratio	0.29	0.40	0.09	0.17	0.25			0.22	0.10		0.29	0.07

Intersection Summary

Area Type:	Other
Cycle Length:	100
Actuated Cycle Length:	67.8
Natural Cycle:	65
Control Type:	Actuated-Uncoordinated
Maximum v/c Ratio:	0.63
Intersection Signal Delay:	17.2
Intersection LOS:	B
Intersection Capacity Utilization	60.4%
ICU Level of Service	B
Analysis Period (min)	15

Splits and Phases: 5: 83rd Ave NE & SR-528

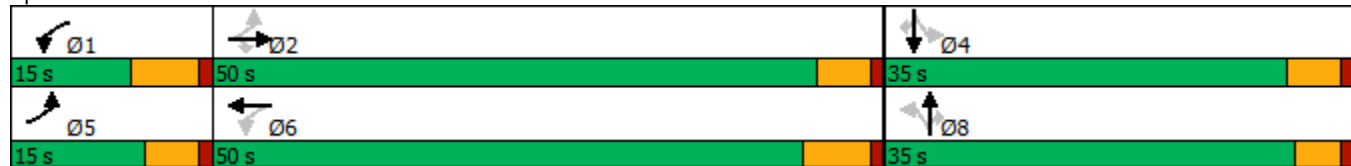

Intersection						
Int Delay, s/veh	0.1					
Movement	EBL	EBT	WBT	WBR	SBL	SBR
Lane Configurations		↔	↔		↔	
Traffic Vol, veh/h	3	330	482	20	2	3
Future Vol, veh/h	3	330	482	20	2	3
Conflicting Peds, #/hr	0	0	0	0	0	0
Sign Control	Free	Free	Free	Free	Stop	Stop
RT Channelized	-	None	-	None	-	None
Storage Length	-	-	-	-	0	-
Veh in Median Storage, #	-	0	0	-	0	-
Grade, %	-	0	0	-	0	-
Peak Hour Factor	93	93	93	93	93	93
Heavy Vehicles, %	3	3	3	3	3	2
Mvmt Flow	3	355	518	22	2	3

Major/Minor	Major1	Major2	Minor2		
Conflicting Flow All	540	0	-	0	890 529
Stage 1	-	-	-	-	529 -
Stage 2	-	-	-	-	361 -
Critical Hdwy	4.13	-	-	-	6.43 6.22
Critical Hdwy Stg 1	-	-	-	-	5.43 -
Critical Hdwy Stg 2	-	-	-	-	5.43 -
Follow-up Hdwy	2.227	-	-	-	3.527 3.318
Pot Cap-1 Maneuver	1023	-	-	-	312 550
Stage 1	-	-	-	-	589 -
Stage 2	-	-	-	-	703 -
Platoon blocked, %		-	-	-	
Mov Cap-1 Maneuver	1023	-	-	-	311 550
Mov Cap-2 Maneuver	-	-	-	-	311 -
Stage 1	-	-	-	-	587 -
Stage 2	-	-	-	-	703 -

Approach	EB	WB	SB
HCM Control Delay, s	0.1	0	13.7
HCM LOS			B

Minor Lane/Major Mvmt	EBL	EBT	WBT	WBR	SBLn1
Capacity (veh/h)	1023	-	-	-	421
HCM Lane V/C Ratio	0.003	-	-	-	0.013
HCM Control Delay (s)	8.5	0	-	-	13.7
HCM Lane LOS	A	A	-	-	B
HCM 95th %tile Q(veh)	0	-	-	-	0

Intersection

Int Delay, s/veh 2.4

Movement	EBL	EBT	EBR	WBL	WBT	WBR	NBL	NBT	NBR	SBL	SBT	SBR
Lane Configurations		↕			↕			↕			↕	
Traffic Vol, veh/h	0	50	3	3	66	9	16	5	1	12	1	7
Future Vol, veh/h	0	50	3	3	66	9	16	5	1	12	1	7
Conflicting Peds, #/hr	0	0	0	0	0	0	0	0	0	0	0	0
Sign Control	Free	Free	Free	Free	Free	Free	Stop	Stop	Stop	Stop	Stop	Stop
RT Channelized	-	-	None	-	-	None	-	-	None	-	-	None
Storage Length	-	-	-	-	-	-	-	-	-	-	-	-
Veh in Median Storage, #	-	0	-	-	0	-	-	0	-	-	0	-
Grade, %	-	0	-	-	0	-	-	0	-	-	0	-
Peak Hour Factor	88	88	88	88	88	88	88	88	88	88	88	88
Heavy Vehicles, %	3	3	3	3	3	3	3	3	3	3	3	2
Mvmt Flow	0	57	3	3	75	10	18	6	1	14	1	8

Major/Minor	Major1		Major2		Minor1		Minor2					
Conflicting Flow All	85	0	0	60	0	0	150	150	59	148	146	80
Stage 1	-	-	-	-	-	-	59	59	-	86	86	-
Stage 2	-	-	-	-	-	-	91	91	-	62	60	-
Critical Hdwy	4.13	-	-	4.13	-	-	7.13	6.53	6.23	7.13	6.53	6.22
Critical Hdwy Stg 1	-	-	-	-	-	-	6.13	5.53	-	6.13	5.53	-
Critical Hdwy Stg 2	-	-	-	-	-	-	6.13	5.53	-	6.13	5.53	-
Follow-up Hdwy	2.227	-	-	2.227	-	-	3.527	4.027	3.327	3.527	4.027	3.318
Pot Cap-1 Maneuver	1505	-	-	1537	-	-	815	740	1004	818	744	980
Stage 1	-	-	-	-	-	-	950	844	-	919	822	-
Stage 2	-	-	-	-	-	-	914	818	-	947	843	-
Platoon blocked, %		-	-		-	-						
Mov Cap-1 Maneuver	1505	-	-	1537	-	-	806	739	1004	811	743	980
Mov Cap-2 Maneuver	-	-	-	-	-	-	806	739	-	811	743	-
Stage 1	-	-	-	-	-	-	950	844	-	919	820	-
Stage 2	-	-	-	-	-	-	904	816	-	940	843	-

Approach	EB	WB	NB	SB
HCM Control Delay, s	0	0.3	9.7	9.3
HCM LOS			A	A

Minor Lane/Major Mvmt	NBLn1	EBL	EBT	EBR	WBL	WBT	WBR	SBLn1
Capacity (veh/h)	797	1505	-	-	1537	-	-	859
HCM Lane V/C Ratio	0.031	-	-	-	0.002	-	-	0.026
HCM Control Delay (s)	9.7	0	-	-	7.3	0	-	9.3
HCM Lane LOS	A	A	-	-	A	A	-	A
HCM 95th %tile Q(veh)	0.1	0	-	-	0	-	-	0.1

Intersection						
Int Delay, s/veh	2.7					
Movement	WBL	WBR	NBT	NBR	SBL	SBT
Lane Configurations	W	W	T			T
Traffic Vol, veh/h	28	64	239	10	49	140
Future Vol, veh/h	28	64	239	10	49	140
Conflicting Peds, #/hr	0	0	0	0	0	0
Sign Control	Stop	Stop	Free	Free	Free	Free
RT Channelized	-	None	-	None	-	None
Storage Length	0	-	-	-	-	-
Veh in Median Storage, #	0	-	0	-	-	0
Grade, %	0	-	0	-	-	0
Peak Hour Factor	93	93	93	93	93	93
Heavy Vehicles, %	4	4	4	4	4	4
Mvmt Flow	30	69	257	11	53	151

Major/Minor	Minor1	Major1	Major2			
Conflicting Flow All	520	263	0	0	268	0
Stage 1	263	-	-	-	-	-
Stage 2	257	-	-	-	-	-
Critical Hdwy	6.44	6.24	-	-	4.14	-
Critical Hdwy Stg 1	5.44	-	-	-	-	-
Critical Hdwy Stg 2	5.44	-	-	-	-	-
Follow-up Hdwy	3.536	3.336	-	-	2.236	-
Pot Cap-1 Maneuver	513	771	-	-	1284	-
Stage 1	776	-	-	-	-	-
Stage 2	781	-	-	-	-	-
Platoon blocked, %			-	-	-	-
Mov Cap-1 Maneuver	490	771	-	-	1284	-
Mov Cap-2 Maneuver	490	-	-	-	-	-
Stage 1	776	-	-	-	-	-
Stage 2	746	-	-	-	-	-

Approach	WB	NB	SB
HCM Control Delay, s	11.5	0	2.1
HCM LOS	B		

Minor Lane/Major Mvmt	NBT	NBRWBLn1	SBL	SBT
Capacity (veh/h)	-	-	656	1284
HCM Lane V/C Ratio	-	-	0.151	0.041
HCM Control Delay (s)	-	-	11.5	7.9
HCM Lane LOS	-	-	B	A
HCM 95th %tile Q(veh)	-	-	0.5	0.1

Lanes, Volumes, Timings
5: 83rd Ave NE & SR-528

87th Townhomes



Lane Group	EBL	EBT	EBR	WBL	WBT	WBR	NBL	NBT	NBR	SBL	SBT	SBR
Lane Configurations												
Traffic Volume (vph)	148	509	105	78	448	129	74	69	77	119	51	57
Future Volume (vph)	148	509	105	78	448	129	74	69	77	119	51	57
Ideal Flow (vphpl)	1900	1900	1900	1900	1900	1900	1900	1900	1900	1900	1900	1900
Storage Length (ft)	250		0	180		160	0		30	0		150
Storage Lanes	1		1	1		1	0		0	0		1
Taper Length (ft)	25			25			25			25		
Lane Util. Factor	1.00	1.00	1.00	1.00	0.95	0.95	1.00	1.00	1.00	1.00	1.00	1.00
Ped Bike Factor	0.99				0.99							0.99
Frt			0.850		0.967			0.953				0.850
Flt Protected	0.950			0.950				0.983			0.966	
Satd. Flow (prot)	1770	1863	1583	1770	3394	0	0	1745	0	0	1799	1583
Flt Permitted	0.328			0.337				0.834			0.612	
Satd. Flow (perm)	607	1863	1583	628	3394	0	0	1481	0	0	1140	1563
Right Turn on Red			Yes			Yes			Yes			Yes
Satd. Flow (RTOR)			109		47			28				98
Link Speed (mph)		30			30			30				30
Link Distance (ft)		3167			1315			3856				1264
Travel Time (s)		72.0			29.9			87.6				28.7
Confl. Peds. (#/hr)	5					5						
Confl. Bikes (#/hr)												1
Peak Hour Factor	0.96	0.96	0.96	0.96	0.96	0.96	0.96	0.96	0.96	0.96	0.96	0.96
Shared Lane Traffic (%)												
Lane Group Flow (vph)	154	530	109	81	601	0	0	229	0	0	177	59
Turn Type	pm+pt	NA	Perm	pm+pt	NA		Perm	NA		Perm	NA	Perm
Protected Phases	5	2		1	6			8				4
Permitted Phases	2		2	6			8			4		4
Detector Phase	5	2	2	1	6		8	8		4	4	4
Switch Phase												
Minimum Initial (s)	4.0	5.0	5.0	5.0	7.0		4.0	4.0		4.0	4.0	4.0
Minimum Split (s)	9.0	19.0	19.0	11.0	20.0		27.5	27.5		26.0	26.0	26.0
Total Split (s)	15.0	50.0	50.0	15.0	50.0		35.0	35.0		35.0	35.0	35.0
Total Split (%)	15.0%	50.0%	50.0%	15.0%	50.0%		35.0%	35.0%		35.0%	35.0%	35.0%
Yellow Time (s)	4.0	4.0	4.0	5.0	5.0		3.5	3.5		4.0	4.0	4.0
All-Red Time (s)	1.0	1.0	1.0	1.0	1.0		1.0	1.0		1.0	1.0	1.0
Lost Time Adjust (s)	0.0	0.0	0.0	0.0	0.0			0.0			0.0	0.0
Total Lost Time (s)	5.0	5.0	5.0	6.0	6.0			4.5			5.0	5.0
Lead/Lag	Lead	Lag	Lag	Lead	Lag							
Lead-Lag Optimize?												
Recall Mode	None	None	None	None	None		None	None		None	None	None
Act Effct Green (s)	38.5	31.2	31.2	31.0	24.6			18.3			17.8	17.8
Actuated g/C Ratio	0.56	0.45	0.45	0.45	0.36			0.26			0.26	0.26
v/c Ratio	0.31	0.63	0.14	0.21	0.49			0.56			0.61	0.12
Control Delay	9.1	21.0	3.8	9.4	17.3			26.5			34.4	2.2
Queue Delay	0.0	0.0	0.0	0.0	0.0			0.0			0.0	0.0
Total Delay	9.1	21.0	3.8	9.4	17.3			26.5			34.4	2.2
LOS	A	C	A	A	B			C			C	A
Approach Delay		16.3			16.4			26.5			26.3	
Approach LOS		B			B			C			C	

Lanes, Volumes, Timings
5: 83rd Ave NE & SR-528

87th Townhomes



Lane Group	EBL	EBT	EBR	WBL	WBT	WBR	NBL	NBT	NBR	SBL	SBT	SBR
Queue Length 50th (ft)	29	200	0	15	104			58	0		73	0
Queue Length 95th (ft)	75	410	30	44	184			140	30		173	15
Internal Link Dist (ft)		3087			1235			3776			1184	
Turn Bay Length (ft)	250			180					30			150
Base Capacity (vph)	497	1231	1087	437	2208			619	763		543	743
Starvation Cap Reductn	0	0	0	0	0			0	0		0	0
Spillback Cap Reductn	0	0	0	0	0			0	0		0	0
Storage Cap Reductn	0	0	0	0	0			0	0		0	0
Reduced v/c Ratio	0.34	0.47	0.11	0.20	0.30			0.26	0.12		0.36	0.09

Intersection Summary	
Area Type:	Other
Cycle Length:	100
Actuated Cycle Length:	72.4
Natural Cycle:	65
Control Type:	Actuated-Uncoordinated
Maximum v/c Ratio:	0.67
Intersection Signal Delay:	18.6
Intersection LOS:	B
Intersection Capacity Utilization	64.1%
ICU Level of Service	C
Analysis Period (min)	15

Splits and Phases: 5: 83rd Ave NE & SR-528

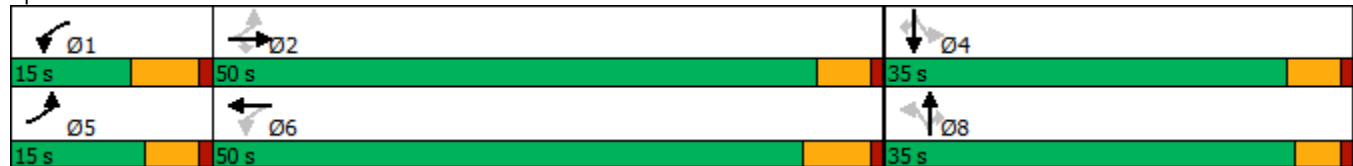

Intersection						
Int Delay, s/veh	0.8					
Movement	EBL	EBT	WBT	WBR	SBL	SBR
Lane Configurations		↔	↔		↔	
Traffic Vol, veh/h	9	330	482	55	28	7
Future Vol, veh/h	9	330	482	55	28	7
Conflicting Peds, #/hr	0	0	0	0	0	0
Sign Control	Free	Free	Free	Free	Stop	Stop
RT Channelized	-	None	-	None	-	None
Storage Length	-	-	-	-	0	-
Veh in Median Storage, #	-	0	0	-	0	-
Grade, %	-	0	0	-	0	-
Peak Hour Factor	93	93	93	93	93	93
Heavy Vehicles, %	3	3	3	3	3	2
Mvmt Flow	10	355	518	59	30	8

Major/Minor	Major1	Major2	Minor2		
Conflicting Flow All	577	0	-	0	923 548
Stage 1	-	-	-	-	548 -
Stage 2	-	-	-	-	375 -
Critical Hdwy	4.13	-	-	-	6.43 6.22
Critical Hdwy Stg 1	-	-	-	-	5.43 -
Critical Hdwy Stg 2	-	-	-	-	5.43 -
Follow-up Hdwy	2.227	-	-	-	3.527 3.318
Pot Cap-1 Maneuver	992	-	-	-	298 536
Stage 1	-	-	-	-	577 -
Stage 2	-	-	-	-	693 -
Platoon blocked, %		-	-	-	
Mov Cap-1 Maneuver	992	-	-	-	294 536
Mov Cap-2 Maneuver	-	-	-	-	294 -
Stage 1	-	-	-	-	569 -
Stage 2	-	-	-	-	693 -

Approach	EB	WB	SB
HCM Control Delay, s	0.2	0	17.6
HCM LOS			C

Minor Lane/Major Mvmt	EBL	EBT	WBT	WBR	SBLn1
Capacity (veh/h)	992	-	-	-	323
HCM Lane V/C Ratio	0.01	-	-	-	0.117
HCM Control Delay (s)	8.7	0	-	-	17.6
HCM Lane LOS	A	A	-	-	C
HCM 95th %tile Q(veh)	0	-	-	-	0.4

SITE LAYOUT

Site: 2 [2035 Baseline (City Model) (Site Folder: General)]

87th Avenue NE at 40th Street NE
Site Category: PM Peak-Hour
Roundabout

Layout pictures are schematic functional drawings reflecting input data. They are not design drawings.

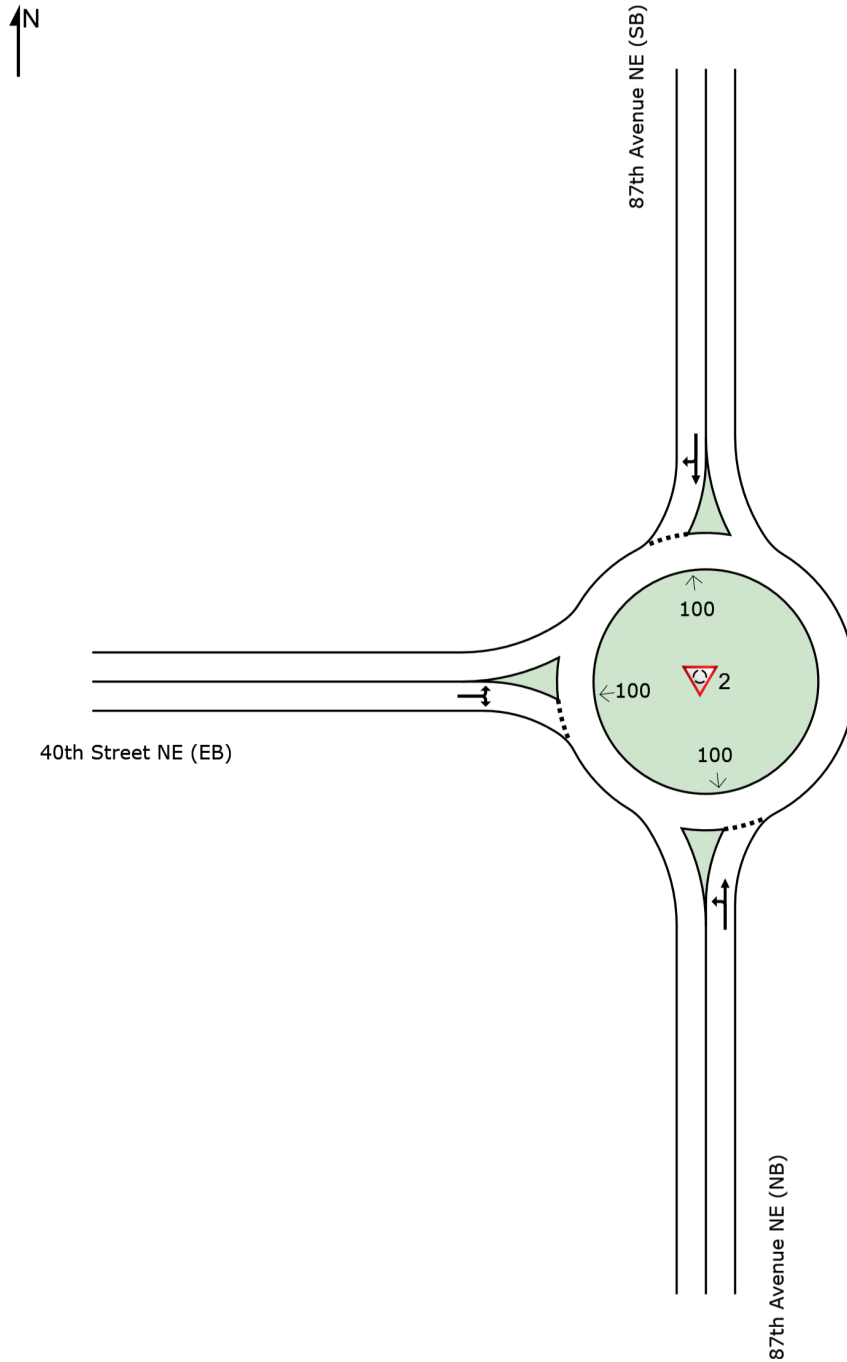

MOVEMENT FLOWS FOR SITE (INPUT)

Approach movement input flow rates (veh/h)

All Movement Classes

Site: 2 [2035 Baseline (City Model) (Site Folder: General)]

87th Avenue NE at 40th Street NE
Site Category: PM Peak-Hour
Roundabout

Use the button below to open or close all popup boxes. Click value labels to open selected ones.
Click and drag popup boxes to move to preferred positions.

Close All Popups

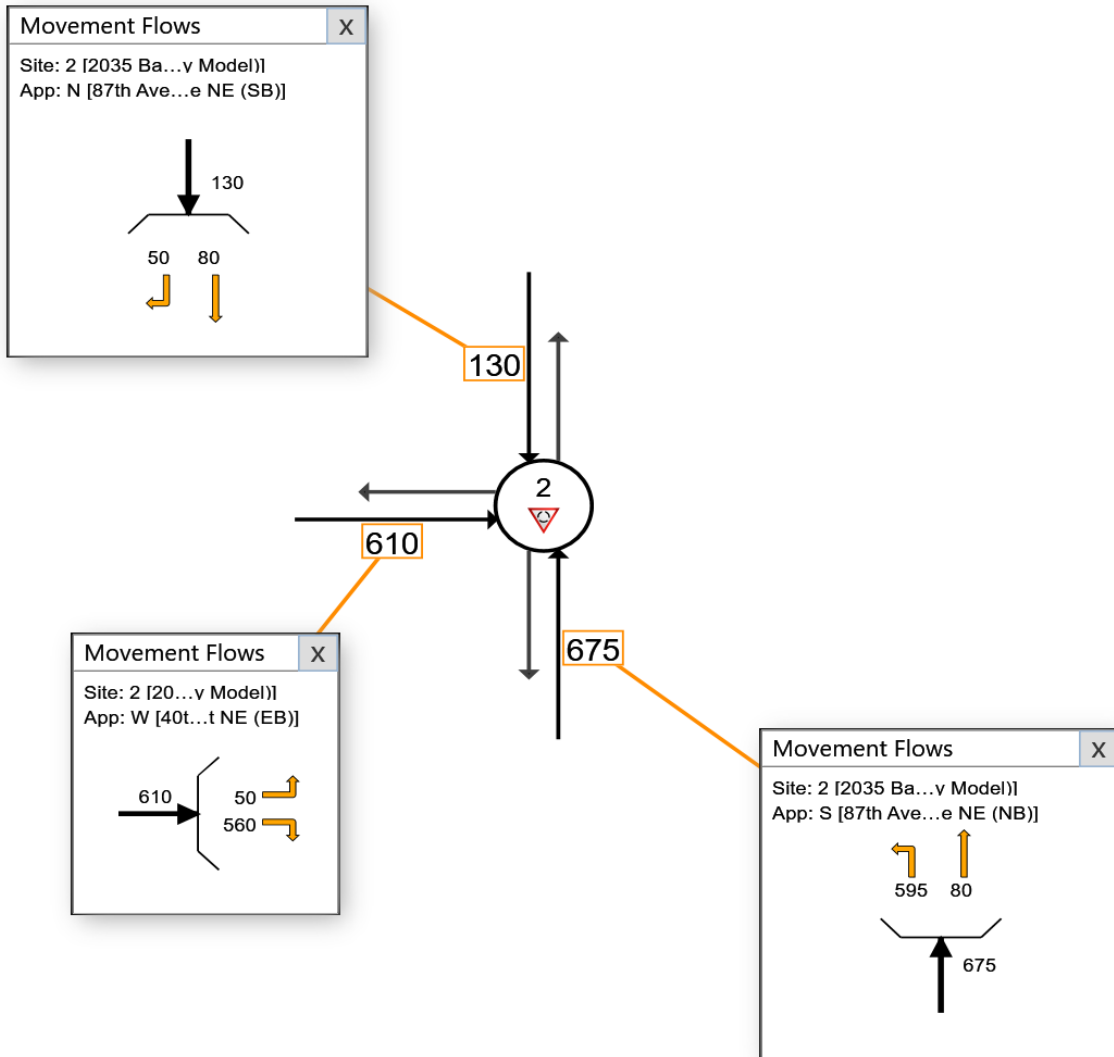

MOVEMENT SUMMARY

Site: 2 [2035 Baseline (City Model) (Site Folder: General)]

87th Avenue NE at 40th Street NE
 Site Category: PM Peak-Hour
 Roundabout

Vehicle Movement Performance														
Mov ID	Turn	INPUT VOLUMES		DEMAND FLOWS		Deg. Satn v/c	Aver. Delay sec	Level of Service	95% BACK OF QUEUE		Prop. Que	Effective Stop Rate	Aver. No. Cycles	Aver. Speed mph
		[Total veh/h	HV] %	[Total veh/h	HV] %				[Veh. veh	Dist] ft				
South: 87th Avenue NE (NB)														
3	L2	595	3.0	647	3.0	0.580	10.4	LOS B	5.8	149.6	0.37	0.58	0.37	34.4
8	T1	80	3.0	87	3.0	0.580	4.4	LOS A	5.8	149.6	0.37	0.58	0.37	34.4
Approach		675	3.0	734	3.0	0.580	9.7	LOS A	5.8	149.6	0.37	0.58	0.37	34.4
North: 87th Avenue NE (SB)														
4	T1	80	3.0	87	3.0	0.189	8.1	LOS A	1.1	29.3	0.72	0.73	0.72	35.5
14	R2	50	3.0	54	3.0	0.189	8.1	LOS A	1.1	29.3	0.72	0.73	0.72	34.5
Approach		130	3.0	141	3.0	0.189	8.1	LOS A	1.1	29.3	0.72	0.73	0.72	35.1
West: 40th Street NE (EB)														
5	L2	50	3.0	54	3.0	0.546	10.6	LOS B	5.3	134.8	0.46	0.51	0.46	36.7
12	R2	560	3.0	609	3.0	0.546	4.7	LOS A	5.3	134.8	0.46	0.51	0.46	35.5
Approach		610	3.0	663	3.0	0.546	5.2	LOS A	5.3	134.8	0.46	0.51	0.46	35.6
All Vehicles		1415	3.0	1538	3.0	0.580	7.6	LOS A	5.8	149.6	0.44	0.56	0.44	35.0

Site Level of Service (LOS) Method: Delay & Degree of Saturation (SIDRA). Site LOS Method is specified in the Parameter Settings dialog (Site tab).

Roundabout LOS Method: Same as Signalised Intersections.

Vehicle movement LOS values are based on average delay and v/c ratio (degree of saturation) per movement.

Intersection and Approach LOS values are based on average delay for all movements (v/c not used).

Roundabout Capacity Model: SIDRA Standard.

Delay Model: SIDRA Standard (Geometric Delay is included).

Queue Model: HCM Queue Formula.

Gap-Acceptance Capacity: SIDRA Standard (Akçelik M3D).

HV (%) values are calculated for All Movement Classes of All Heavy Vehicle Model Designation.

SIDRA INTERSECTION 9.0 | Copyright © 2000-2020 Akcelik and Associates Pty Ltd | sidrasolutions.com

Organisation: KIMLEY-HORN & ASSOCIATES INC | Licence: NETWORK / Enterprise | Processed: Wednesday, September 14, 2022 1:28:35 PM

Project: K:\SNO_TPTO\2022\22-013 87th Townhomes\Intersection Analysis\Sidra\87th Ave at 40th St.sip9

Intersection												
Int Delay, s/veh	2.8											
Movement	EBL	EBT	EBR	WBL	WBT	WBR	NBL	NBT	NBR	SBL	SBT	SBR
Lane Configurations		↕			↕			↕			↕	
Traffic Vol, veh/h	0	50	21	5	66	9	30	5	2	12	1	7
Future Vol, veh/h	0	50	21	5	66	9	30	5	2	12	1	7
Conflicting Peds, #/hr	0	0	0	0	0	0	0	0	0	0	0	0
Sign Control	Free	Free	Free	Free	Free	Free	Stop	Stop	Stop	Stop	Stop	Stop
RT Channelized	-	-	None	-	-	None	-	-	None	-	-	None
Storage Length	-	-	-	-	-	-	-	-	-	-	-	-
Veh in Median Storage, #	-	0	-	-	0	-	-	0	-	-	0	-
Grade, %	-	0	-	-	0	-	-	0	-	-	0	-
Peak Hour Factor	88	88	88	88	88	88	88	88	88	88	88	88
Heavy Vehicles, %	3	3	3	3	3	3	3	3	3	3	3	3
Mvmt Flow	0	57	24	6	75	10	34	6	2	14	1	8

Major/Minor	Major1			Major2			Minor1			Minor2		
Conflicting Flow All	85	0	0	81	0	0	166	166	69	165	173	80
Stage 1	-	-	-	-	-	-	69	69	-	92	92	-
Stage 2	-	-	-	-	-	-	97	97	-	73	81	-
Critical Hdwy	4.13	-	-	4.13	-	-	7.13	6.53	6.23	7.13	6.53	6.23
Critical Hdwy Stg 1	-	-	-	-	-	-	6.13	5.53	-	6.13	5.53	-
Critical Hdwy Stg 2	-	-	-	-	-	-	6.13	5.53	-	6.13	5.53	-
Follow-up Hdwy	2.227	-	-	2.227	-	-	3.527	4.027	3.327	3.527	4.027	3.327
Pot Cap-1 Maneuver	1505	-	-	1510	-	-	796	725	991	797	718	977
Stage 1	-	-	-	-	-	-	939	835	-	913	817	-
Stage 2	-	-	-	-	-	-	907	813	-	934	826	-
Platoon blocked, %	-	-	-	-	-	-	-	-	-	-	-	-
Mov Cap-1 Maneuver	1505	-	-	1510	-	-	786	722	991	788	715	977
Mov Cap-2 Maneuver	-	-	-	-	-	-	786	722	-	788	715	-
Stage 1	-	-	-	-	-	-	939	835	-	913	814	-
Stage 2	-	-	-	-	-	-	895	810	-	926	826	-

Approach	EB			WB			NB			SB		
HCM Control Delay, s	0			0.5			9.8			9.4		
HCM LOS							A			A		

Minor Lane/Major Mvmt	NBLn1	EBL	EBT	EBR	WBL	WBT	WBR	SBLn1
Capacity (veh/h)	785	1505	-	-	1510	-	-	841
HCM Lane V/C Ratio	0.054	-	-	-	0.004	-	-	0.027
HCM Control Delay (s)	9.8	0	-	-	7.4	0	-	9.4
HCM Lane LOS	A	A	-	-	A	A	-	A
HCM 95th %tile Q(veh)	0.2	0	-	-	0	-	-	0.1

Intersection						
Int Delay, s/veh	3.1					
Movement	WBL	WBR	NBT	NBR	SBL	SBT
Lane Configurations	W		T			T
Traffic Vol, veh/h	30	76	239	13	64	140
Future Vol, veh/h	30	76	239	13	64	140
Conflicting Peds, #/hr	0	0	0	0	0	0
Sign Control	Stop	Stop	Free	Free	Free	Free
RT Channelized	-	None	-	None	-	None
Storage Length	0	-	-	-	-	-
Veh in Median Storage, #	0	-	0	-	-	0
Grade, %	0	-	0	-	-	0
Peak Hour Factor	93	93	93	93	93	93
Heavy Vehicles, %	4	4	4	4	4	4
Mvmt Flow	32	82	257	14	69	151

Major/Minor	Minor1	Major1	Major2			
Conflicting Flow All	553	264	0	0	271	0
Stage 1	264	-	-	-	-	-
Stage 2	289	-	-	-	-	-
Critical Hdwy	6.44	6.24	-	-	4.14	-
Critical Hdwy Stg 1	5.44	-	-	-	-	-
Critical Hdwy Stg 2	5.44	-	-	-	-	-
Follow-up Hdwy	3.536	3.336	-	-	2.236	-
Pot Cap-1 Maneuver	491	770	-	-	1281	-
Stage 1	776	-	-	-	-	-
Stage 2	756	-	-	-	-	-
Platoon blocked, %			-	-	-	-
Mov Cap-1 Maneuver	462	770	-	-	1281	-
Mov Cap-2 Maneuver	462	-	-	-	-	-
Stage 1	776	-	-	-	-	-
Stage 2	711	-	-	-	-	-

Approach	WB	NB	SB
HCM Control Delay, s	11.7	0	2.5
HCM LOS	B		

Minor Lane/Major Mvmt	NBT	NBRWBLn1	SBL	SBT
Capacity (veh/h)	-	-	648	1281
HCM Lane V/C Ratio	-	-	0.176	0.054
HCM Control Delay (s)	-	-	11.7	8
HCM Lane LOS	-	-	B	A
HCM 95th %tile Q(veh)	-	-	0.6	0.2

Lanes, Volumes, Timings
5: 83rd Ave NE & SR-528

87th Townhomes



Lane Group	EBL	EBT	EBR	WBL	WBT	WBR	NBL	NBT	NBR	SBL	SBT	SBR
Lane Configurations												
Traffic Volume (vph)	162	556	127	86	490	141	91	76	85	130	58	62
Future Volume (vph)	162	556	127	86	490	141	91	76	85	130	58	62
Ideal Flow (vphpl)	1900	1900	1900	1900	1900	1900	1900	1900	1900	1900	1900	1900
Storage Length (ft)	250		0	180		160	0		30	0		150
Storage Lanes	1		1	1		1	0		0	0		1
Taper Length (ft)	25			25			25			25		
Lane Util. Factor	1.00	1.00	1.00	1.00	0.95	0.95	1.00	1.00	1.00	1.00	1.00	1.00
Ped Bike Factor	0.99				0.99							0.99
Frt			0.850		0.966			0.954				0.850
Flt Protected	0.950			0.950				0.982			0.967	
Satd. Flow (prot)	1770	1863	1583	1770	3390	0	0	1745	0	0	1801	1583
Flt Permitted	0.301			0.288				0.774			0.586	
Satd. Flow (perm)	558	1863	1583	536	3390	0	0	1375	0	0	1092	1563
Right Turn on Red			Yes			Yes			Yes			Yes
Satd. Flow (RTOR)			132		47			26				98
Link Speed (mph)		30			30			30				30
Link Distance (ft)		3167			1315			3856				1264
Travel Time (s)		72.0			29.9			87.6				28.7
Confl. Peds. (#/hr)	5						5					
Confl. Bikes (#/hr)												1
Peak Hour Factor	0.96	0.96	0.96	0.96	0.96	0.96	0.96	0.96	0.96	0.96	0.96	0.96
Shared Lane Traffic (%)												
Lane Group Flow (vph)	169	579	132	90	657	0	0	263	0	0	195	65
Turn Type	pm+pt	NA	Perm	pm+pt	NA		Perm	NA		Perm	NA	Perm
Protected Phases	5	2		1	6			8				4
Permitted Phases	2		2	6			8			4		4
Detector Phase	5	2	2	1	6		8	8		4	4	4
Switch Phase												
Minimum Initial (s)	4.0	5.0	5.0	5.0	7.0		4.0	4.0		4.0	4.0	4.0
Minimum Split (s)	9.0	19.0	19.0	11.0	20.0		27.5	27.5		26.0	26.0	26.0
Total Split (s)	15.0	50.0	50.0	15.0	50.0		35.0	35.0		35.0	35.0	35.0
Total Split (%)	15.0%	50.0%	50.0%	15.0%	50.0%		35.0%	35.0%		35.0%	35.0%	35.0%
Yellow Time (s)	4.0	4.0	4.0	5.0	5.0		3.5	3.5		4.0	4.0	4.0
All-Red Time (s)	1.0	1.0	1.0	1.0	1.0		1.0	1.0		1.0	1.0	1.0
Lost Time Adjust (s)	0.0	0.0	0.0	0.0	0.0			0.0			0.0	0.0
Total Lost Time (s)	5.0	5.0	5.0	6.0	6.0			4.5			5.0	5.0
Lead/Lag	Lead	Lag	Lag	Lead	Lag							
Lead-Lag Optimize?												
Recall Mode	None	None	None	None	None		None	None		None	None	None
Act Effct Green (s)	41.6	34.2	34.2	34.2	27.6			20.0			19.5	19.5
Actuated g/C Ratio	0.56	0.46	0.46	0.46	0.37			0.27			0.26	0.26
v/c Ratio	0.36	0.67	0.16	0.25	0.51			0.67			0.68	0.13
Control Delay	10.0	22.8	3.6	10.1	18.1			32.6			39.4	2.9
Queue Delay	0.0	0.0	0.0	0.0	0.0			0.0			0.0	0.0
Total Delay	10.0	22.8	3.6	10.1	18.1			32.6			39.4	2.9
LOS	A	C	A	B	B			C			D	A
Approach Delay		17.4			17.1			32.6			30.3	
Approach LOS		B			B			C			C	

Lanes, Volumes, Timings
5: 83rd Ave NE & SR-528

87th Townhomes



Lane Group	EBL	EBT	EBR	WBL	WBT	WBR	NBL	NBT	NBR	SBL	SBT	SBR
Queue Length 50th (ft)	30	204	0	16	105			64	0		75	0
Queue Length 95th (ft)	75	410	32	45	184			152	30		177	15
Internal Link Dist (ft)		3087			1235			3776			1184	
Turn Bay Length (ft)	250			180					30			150
Base Capacity (vph)	494	1221	1083	433	2190			581	758		521	738
Starvation Cap Reductn	0	0	0	0	0			0	0		0	0
Spillback Cap Reductn	0	0	0	0	0			0	0		0	0
Storage Cap Reductn	0	0	0	0	0			0	0		0	0
Reduced v/c Ratio	0.34	0.47	0.12	0.21	0.30			0.30	0.12		0.37	0.09

Intersection Summary	
Area Type:	Other
Cycle Length:	100
Actuated Cycle Length:	73
Natural Cycle:	65
Control Type:	Actuated-Uncoordinated
Maximum v/c Ratio:	0.67
Intersection Signal Delay:	18.9
Intersection LOS:	B
Intersection Capacity Utilization	64.3%
ICU Level of Service	C
Analysis Period (min)	15

Splits and Phases: 5: 83rd Ave NE & SR-528

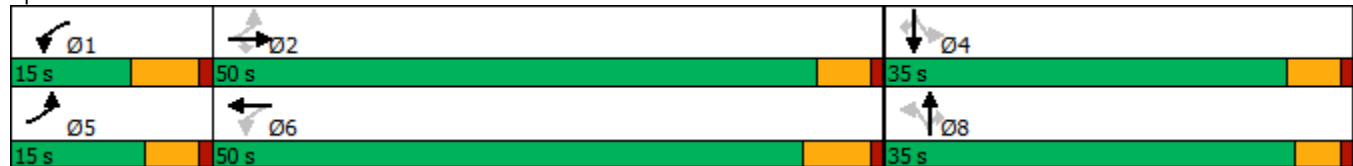

Intersection						
Int Delay, s/veh	0.1					
Movement	EBL	EBT	WBT	WBR	SBL	SBR
Lane Configurations		↔	↔		↔	
Traffic Vol, veh/h	4	394	575	23	3	4
Future Vol, veh/h	4	394	575	23	3	4
Conflicting Peds, #/hr	0	0	0	0	0	0
Sign Control	Free	Free	Free	Free	Stop	Stop
RT Channelized	-	None	-	None	-	None
Storage Length	-	-	-	-	0	-
Veh in Median Storage, #	-	0	0	-	0	-
Grade, %	-	0	0	-	0	-
Peak Hour Factor	93	93	93	93	93	93
Heavy Vehicles, %	3	3	3	3	3	2
Mvmt Flow	4	424	618	25	3	4

Major/Minor	Major1	Major2	Minor2		
Conflicting Flow All	643	0	0	1063	631
Stage 1	-	-	-	631	-
Stage 2	-	-	-	432	-
Critical Hdwy	4.13	-	-	6.43	6.22
Critical Hdwy Stg 1	-	-	-	5.43	-
Critical Hdwy Stg 2	-	-	-	5.43	-
Follow-up Hdwy	2.227	-	-	3.527	3.318
Pot Cap-1 Maneuver	937	-	-	246	481
Stage 1	-	-	-	528	-
Stage 2	-	-	-	652	-
Platoon blocked, %	-	-	-	-	-
Mov Cap-1 Maneuver	937	-	-	245	481
Mov Cap-2 Maneuver	-	-	-	245	-
Stage 1	-	-	-	525	-
Stage 2	-	-	-	652	-

Approach	EB	WB	SB
HCM Control Delay, s	0.1	0	15.8
HCM LOS			C

Minor Lane/Major Mvmt	EBL	EBT	WBT	WBR	SBLn1
Capacity (veh/h)	937	-	-	-	340
HCM Lane V/C Ratio	0.005	-	-	-	0.022
HCM Control Delay (s)	8.9	0	-	-	15.8
HCM Lane LOS	A	A	-	-	C
HCM 95th %tile Q(veh)	0	-	-	-	0.1

Intersection												
Int Delay, s/veh	2.5											
Movement	EBL	EBT	EBR	WBL	WBT	WBR	NBL	NBT	NBR	SBL	SBT	SBR
Lane Configurations		↕			↕			↕			↕	
Traffic Vol, veh/h	0	60	4	4	78	10	20	7	1	14	1	8
Future Vol, veh/h	0	60	4	4	78	10	20	7	1	14	1	8
Conflicting Peds, #/hr	0	0	0	0	0	0	0	0	0	0	0	0
Sign Control	Free	Free	Free	Free	Free	Free	Stop	Stop	Stop	Stop	Stop	Stop
RT Channelized	-	-	None	-	-	None	-	-	None	-	-	None
Storage Length	-	-	-	-	-	-	-	-	-	-	-	-
Veh in Median Storage, #	-	0	-	-	0	-	-	0	-	-	0	-
Grade, %	-	0	-	-	0	-	-	0	-	-	0	-
Peak Hour Factor	88	88	88	88	88	88	88	88	88	88	88	88
Heavy Vehicles, %	3	3	3	3	3	3	3	3	3	3	3	3
Mvmt Flow	0	68	5	5	89	11	23	8	1	16	1	9

Major/Minor	Major1			Major2			Minor1			Minor2		
Conflicting Flow All	100	0	0	73	0	0	181	181	71	180	178	95
Stage 1	-	-	-	-	-	-	71	71	-	105	105	-
Stage 2	-	-	-	-	-	-	110	110	-	75	73	-
Critical Hdwy	4.13	-	-	4.13	-	-	7.13	6.53	6.23	7.13	6.53	6.23
Critical Hdwy Stg 1	-	-	-	-	-	-	6.13	5.53	-	6.13	5.53	-
Critical Hdwy Stg 2	-	-	-	-	-	-	6.13	5.53	-	6.13	5.53	-
Follow-up Hdwy	2.227	-	-	2.227	-	-	3.527	4.027	3.327	3.527	4.027	3.327
Pot Cap-1 Maneuver	1486	-	-	1520	-	-	778	711	989	779	714	959
Stage 1	-	-	-	-	-	-	936	834	-	898	806	-
Stage 2	-	-	-	-	-	-	893	802	-	932	832	-
Platoon blocked, %		-	-		-	-						
Mov Cap-1 Maneuver	1486	-	-	1520	-	-	768	709	989	770	712	959
Mov Cap-2 Maneuver	-	-	-	-	-	-	768	709	-	770	712	-
Stage 1	-	-	-	-	-	-	936	834	-	898	804	-
Stage 2	-	-	-	-	-	-	881	800	-	922	832	-

Approach	EB			WB			NB			SB		
HCM Control Delay, s	0			0.3			10			9.5		
HCM LOS							B			A		

Minor Lane/Major Mvmt	NBLn1	EBL	EBT	EBR	WBL	WBT	WBR	SBLn1
Capacity (veh/h)	758	1486	-	-	1520	-	-	824
HCM Lane V/C Ratio	0.042	-	-	-	0.003	-	-	0.032
HCM Control Delay (s)	10	0	-	-	7.4	0	-	9.5
HCM Lane LOS	B	A	-	-	A	A	-	A
HCM 95th %tile Q(veh)	0.1	0	-	-	0	-	-	0.1

Intersection						
Int Delay, s/veh	2.9					
Movement	WBL	WBR	NBT	NBR	SBL	SBT
Lane Configurations						
Traffic Vol, veh/h	34	77	286	12	59	167
Future Vol, veh/h	34	77	286	12	59	167
Conflicting Peds, #/hr	0	0	0	0	0	0
Sign Control	Stop	Stop	Free	Free	Free	Free
RT Channelized	-	None	-	None	-	None
Storage Length	0	-	-	-	-	-
Veh in Median Storage, #	0	-	0	-	-	0
Grade, %	0	-	0	-	-	0
Peak Hour Factor	93	93	93	93	93	93
Heavy Vehicles, %	4	4	4	4	4	4
Mvmt Flow	37	83	308	13	63	180

Major/Minor	Minor1	Major1	Major2		
Conflicting Flow All	621	315	0	0	321
Stage 1	315	-	-	-	-
Stage 2	306	-	-	-	-
Critical Hdwy	6.44	6.24	-	-	4.14
Critical Hdwy Stg 1	5.44	-	-	-	-
Critical Hdwy Stg 2	5.44	-	-	-	-
Follow-up Hdwy	3.536	3.336	-	-	2.236
Pot Cap-1 Maneuver	448	721	-	-	1228
Stage 1	735	-	-	-	-
Stage 2	742	-	-	-	-
Platoon blocked, %			-	-	-
Mov Cap-1 Maneuver	422	721	-	-	1228
Mov Cap-2 Maneuver	422	-	-	-	-
Stage 1	735	-	-	-	-
Stage 2	700	-	-	-	-

Approach	WB	NB	SB
HCM Control Delay, s	12.6	0	2.1
HCM LOS	B		

Minor Lane/Major Mvmt	NBT	NBRWBLn1	SBL	SBT
Capacity (veh/h)	-	-	592	1228
HCM Lane V/C Ratio	-	-	0.202	0.052
HCM Control Delay (s)	-	-	12.6	8.1
HCM Lane LOS	-	-	B	A
HCM 95th %tile Q(veh)	-	-	0.7	0.2

Intersection						
Int Delay, s/veh	0.3					
Movement	EBL	EBT	WBT	WBR	SBL	SBR
Lane Configurations		↶	↷		↶	↷
Traffic Vol, veh/h	10	394	575	25	5	8
Future Vol, veh/h	10	394	575	25	5	8
Conflicting Peds, #/hr	0	0	0	0	0	0
Sign Control	Free	Free	Free	Free	Stop	Stop
RT Channelized	-	None	-	None	-	None
Storage Length	-	-	-	-	0	-
Veh in Median Storage, #	-	0	0	-	0	-
Grade, %	-	0	0	-	0	-
Peak Hour Factor	93	93	93	93	93	93
Heavy Vehicles, %	3	3	3	3	3	2
Mvmt Flow	11	424	618	27	5	9

Major/Minor	Major1	Major2	Minor2		
Conflicting Flow All	645	0	0	1078	632
Stage 1	-	-	-	632	-
Stage 2	-	-	-	446	-
Critical Hdwy	4.13	-	-	6.43	6.22
Critical Hdwy Stg 1	-	-	-	5.43	-
Critical Hdwy Stg 2	-	-	-	5.43	-
Follow-up Hdwy	2.227	-	-	3.527	3.318
Pot Cap-1 Maneuver	935	-	-	241	480
Stage 1	-	-	-	528	-
Stage 2	-	-	-	643	-
Platoon blocked, %	-	-	-	-	-
Mov Cap-1 Maneuver	935	-	-	237	480
Mov Cap-2 Maneuver	-	-	-	237	-
Stage 1	-	-	-	520	-
Stage 2	-	-	-	643	-

Approach	EB	WB	SB
HCM Control Delay, s	0.2	0	15.9
HCM LOS			C

Minor Lane/Major Mvmt	EBL	EBT	WBT	WBR	SBLn1
Capacity (veh/h)	935	-	-	-	344
HCM Lane V/C Ratio	0.012	-	-	-	0.041
HCM Control Delay (s)	8.9	0	-	-	15.9
HCM Lane LOS	A	A	-	-	C
HCM 95th %tile Q(veh)	0	-	-	-	0.1

SITE LAYOUT

Site: 2 [2035 Future (City Model + Dev) (Site Folder: General)]

87th Avenue NE at 40th Street NE
Site Category: PM Peak-Hour
Roundabout

Layout pictures are schematic functional drawings reflecting input data. They are not design drawings.

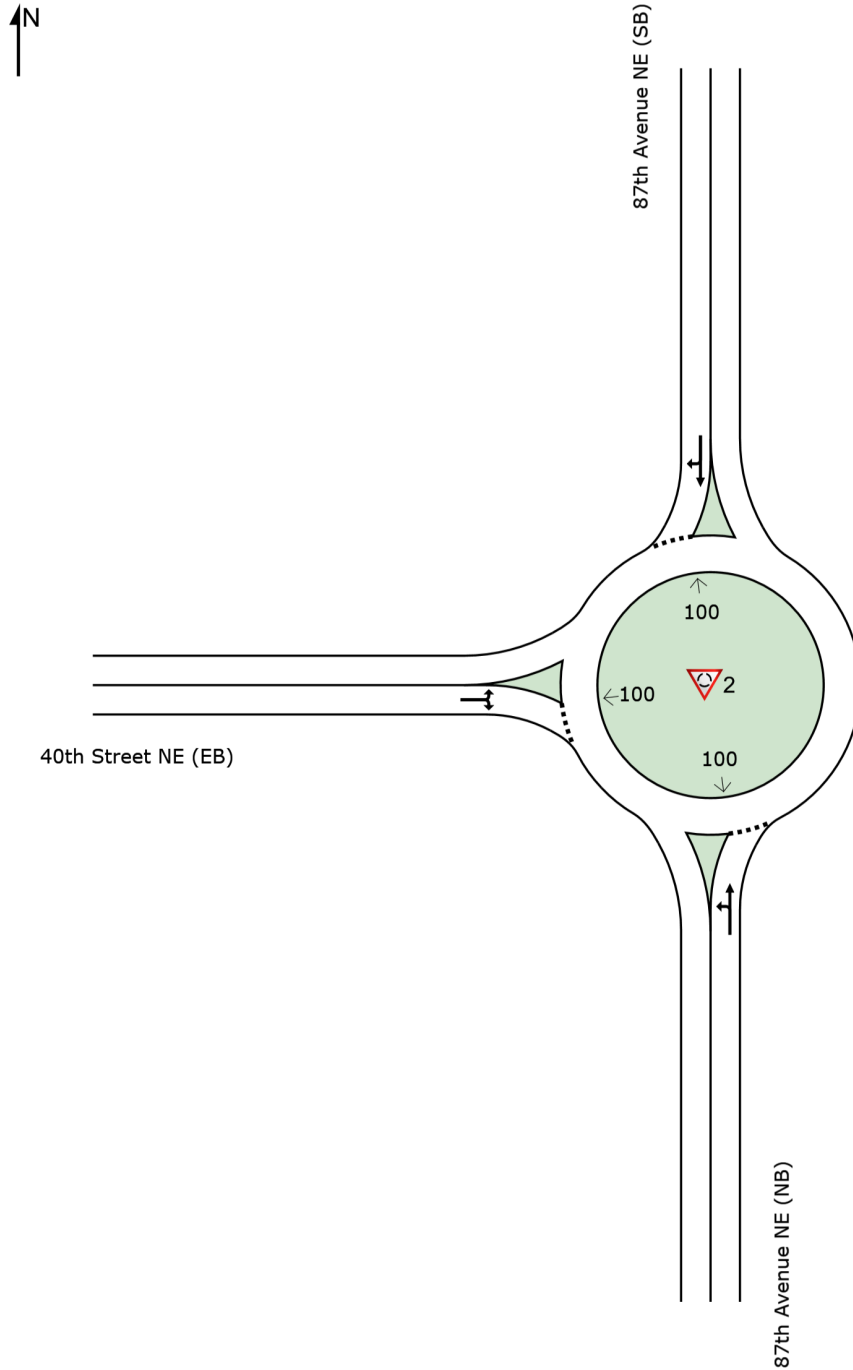

MOVEMENT FLOWS FOR SITE (INPUT)

Approach movement input flow rates (veh/h)

All Movement Classes

Site: 2 [2035 Future (City Model + Dev) (Site Folder: General)]

87th Avenue NE at 40th Street NE
Site Category: PM Peak-Hour
Roundabout

Use the button below to open or close all popup boxes. Click value labels to open selected ones.
Click and drag popup boxes to move to preferred positions.

Close All Popups

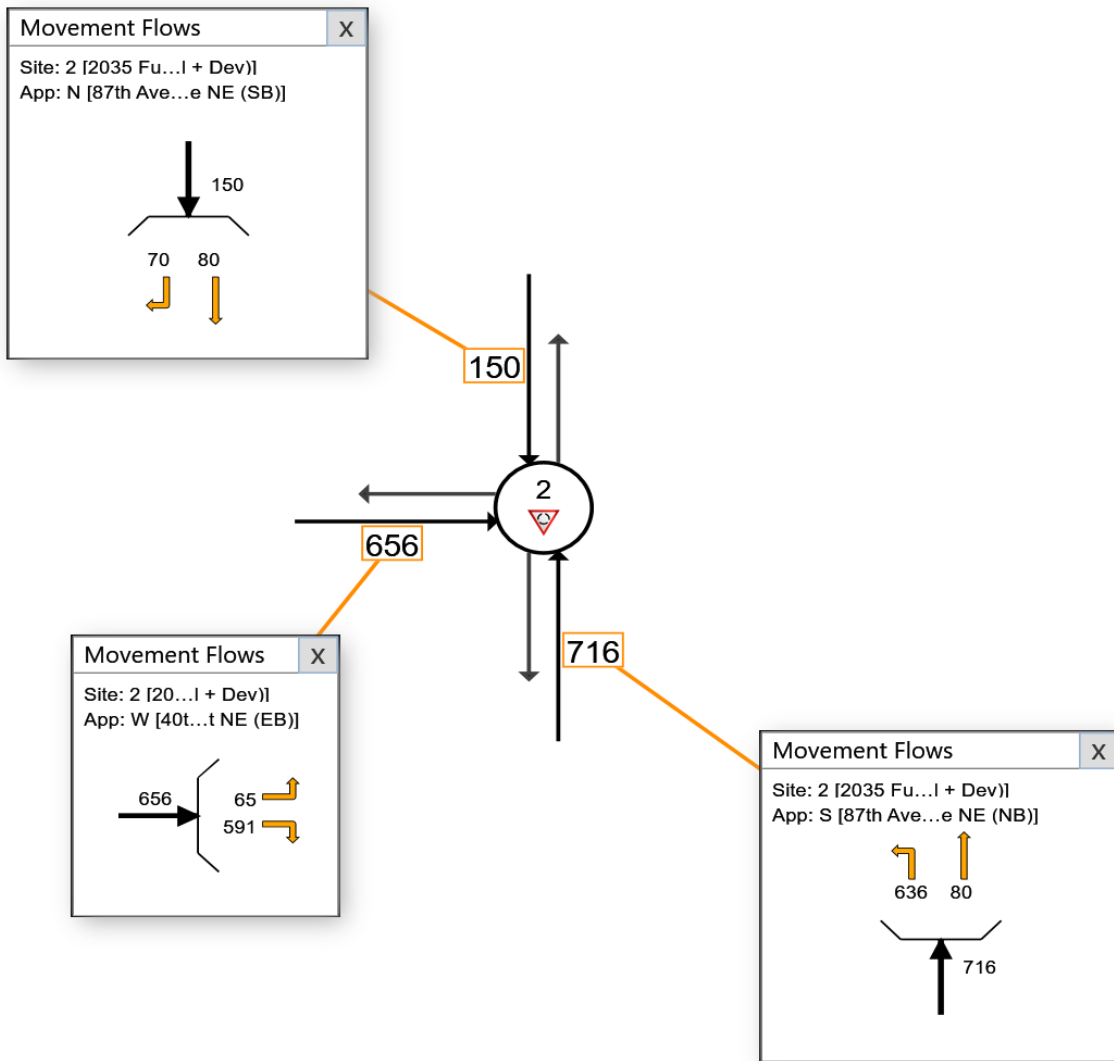

MOVEMENT SUMMARY

Site: 2 [2035 Future (City Model + Dev) (Site Folder: General)]

87th Avenue NE at 40th Street NE
 Site Category: PM Peak-Hour
 Roundabout

Vehicle Movement Performance														
Mov ID	Turn	INPUT VOLUMES		DEMAND FLOWS		Deg. Satn v/c	Aver. Delay sec	Level of Service	95% BACK OF QUEUE		Prop. Que	Effective Stop Rate	Aver. No. Cycles	Aver. Speed mph
		[Total veh/h	HV] %	[Total veh/h	HV] %				[Veh. veh	Dist] ft				
South: 87th Avenue NE (NB)														
3	L2	636	3.0	691	3.0	0.627	10.6	LOS B	6.8	173.3	0.46	0.58	0.46	34.2
8	T1	80	3.0	87	3.0	0.627	4.7	LOS A	6.8	173.3	0.46	0.58	0.46	34.1
Approach		716	3.0	778	3.0	0.627	9.9	LOS A	6.8	173.3	0.46	0.58	0.46	34.2
North: 87th Avenue NE (SB)														
4	T1	80	3.0	87	3.0	0.232	8.6	LOS A	1.5	38.0	0.77	0.78	0.77	35.3
14	R2	70	3.0	76	3.0	0.232	8.7	LOS A	1.5	38.0	0.77	0.78	0.77	34.2
Approach		150	3.0	163	3.0	0.232	8.6	LOS A	1.5	38.0	0.77	0.78	0.77	34.8
West: 40th Street NE (EB)														
5	L2	65	3.0	71	3.0	0.588	10.7	LOS B	6.1	157.0	0.49	0.51	0.49	36.5
12	R2	591	3.0	642	3.0	0.588	4.8	LOS A	6.1	157.0	0.49	0.51	0.49	35.3
Approach		656	3.0	713	3.0	0.588	5.4	LOS A	6.1	157.0	0.49	0.51	0.49	35.5
All Vehicles		1522	3.0	1654	3.0	0.627	7.8	LOS A	6.8	173.3	0.50	0.57	0.50	34.8

Site Level of Service (LOS) Method: Delay & Degree of Saturation (SIDRA). Site LOS Method is specified in the Parameter Settings dialog (Site tab).

Roundabout LOS Method: Same as Signalised Intersections.

Vehicle movement LOS values are based on average delay and v/c ratio (degree of saturation) per movement.

Intersection and Approach LOS values are based on average delay for all movements (v/c not used).

Roundabout Capacity Model: SIDRA Standard.

Delay Model: SIDRA Standard (Geometric Delay is included).

Queue Model: HCM Queue Formula.

Gap-Acceptance Capacity: SIDRA Standard (Akçelik M3D).

HV (%) values are calculated for All Movement Classes of All Heavy Vehicle Model Designation.

SIDRA INTERSECTION 9.0 | Copyright © 2000-2020 Akcelik and Associates Pty Ltd | sidrasolutions.com

Organisation: KIMLEY-HORN & ASSOCIATES INC | Licence: NETWORK / Enterprise | Processed: Thursday, September 15, 2022 6:30:00 AM

Project: K:\SNO_TPTO\2022\22-013 87th Townhomes\Intersection Analysis\Sidra\87th Ave at 40th St.sip9

Intersection												
Int Delay, s/veh	2.9											
Movement	EBL	EBT	EBR	WBL	WBT	WBR	NBL	NBT	NBR	SBL	SBT	SBR
Lane Configurations		↕			↕			↕			↕	
Traffic Vol, veh/h	0	60	14	4	78	10	33	7	1	14	1	8
Future Vol, veh/h	0	60	14	4	78	10	33	7	1	14	1	8
Conflicting Peds, #/hr	0	0	0	0	0	0	0	0	0	0	0	0
Sign Control	Free	Free	Free	Free	Free	Free	Stop	Stop	Stop	Stop	Stop	Stop
RT Channelized	-	-	None	-	-	None	-	-	None	-	-	None
Storage Length	-	-	-	-	-	-	-	-	-	-	-	-
Veh in Median Storage, #	-	0	-	-	0	-	-	0	-	-	0	-
Grade, %	-	0	-	-	0	-	-	0	-	-	0	-
Peak Hour Factor	88	88	88	88	88	88	88	88	88	88	88	88
Heavy Vehicles, %	3	3	3	3	3	3	3	3	3	3	3	3
Mvmt Flow	0	68	16	5	89	11	38	8	1	16	1	9

Major/Minor	Major1			Major2			Minor1			Minor2		
Conflicting Flow All	100	0	0	84	0	0	186	186	76	186	189	95
Stage 1	-	-	-	-	-	-	76	76	-	105	105	-
Stage 2	-	-	-	-	-	-	110	110	-	81	84	-
Critical Hdwy	4.13	-	-	4.13	-	-	7.13	6.53	6.23	7.13	6.53	6.23
Critical Hdwy Stg 1	-	-	-	-	-	-	6.13	5.53	-	6.13	5.53	-
Critical Hdwy Stg 2	-	-	-	-	-	-	6.13	5.53	-	6.13	5.53	-
Follow-up Hdwy	2.227	-	-	2.227	-	-	3.527	4.027	3.327	3.527	4.027	3.327
Pot Cap-1 Maneuver	1486	-	-	1506	-	-	772	707	982	772	704	959
Stage 1	-	-	-	-	-	-	931	830	-	898	806	-
Stage 2	-	-	-	-	-	-	893	802	-	925	823	-
Platoon blocked, %	-	-	-	-	-	-	-	-	-	-	-	-
Mov Cap-1 Maneuver	1486	-	-	1506	-	-	761	704	982	762	701	959
Mov Cap-2 Maneuver	-	-	-	-	-	-	761	704	-	762	701	-
Stage 1	-	-	-	-	-	-	931	830	-	898	803	-
Stage 2	-	-	-	-	-	-	880	799	-	915	823	-

Approach	EB			WB			NB			SB		
HCM Control Delay, s	0			0.3			10.1			9.6		
HCM LOS							B			A		

Minor Lane/Major Mvmt	NBLn1	EBL	EBT	EBR	WBL	WBT	WBR	SBLn1
Capacity (veh/h)	755	1486	-	-	1506	-	-	817
HCM Lane V/C Ratio	0.062	-	-	-	0.003	-	-	0.032
HCM Control Delay (s)	10.1	0	-	-	7.4	0	-	9.6
HCM Lane LOS	B	A	-	-	A	A	-	A
HCM 95th %tile Q(veh)	0.2	0	-	-	0	-	-	0.1

Intersection						
Int Delay, s/veh	3.2					
Movement	WBL	WBR	NBT	NBR	SBL	SBT
Lane Configurations	T		T		T	
Traffic Vol, veh/h	34	87	286	12	72	167
Future Vol, veh/h	34	87	286	12	72	167
Conflicting Peds, #/hr	0	0	0	0	0	0
Sign Control	Stop	Stop	Free	Free	Free	Free
RT Channelized	-	None	-	None	-	None
Storage Length	0	-	-	-	-	-
Veh in Median Storage, #	0	-	0	-	-	0
Grade, %	0	-	0	-	-	0
Peak Hour Factor	93	93	93	93	93	93
Heavy Vehicles, %	4	4	4	4	4	4
Mvmt Flow	37	94	308	13	77	180

Major/Minor	Minor1	Major1	Major2			
Conflicting Flow All	649	315	0	0	321	0
Stage 1	315	-	-	-	-	-
Stage 2	334	-	-	-	-	-
Critical Hdwy	6.44	6.24	-	-	4.14	-
Critical Hdwy Stg 1	5.44	-	-	-	-	-
Critical Hdwy Stg 2	5.44	-	-	-	-	-
Follow-up Hdwy	3.536	3.336	-	-	2.236	-
Pot Cap-1 Maneuver	431	721	-	-	1228	-
Stage 1	735	-	-	-	-	-
Stage 2	721	-	-	-	-	-
Platoon blocked, %			-	-		-
Mov Cap-1 Maneuver	401	721	-	-	1228	-
Mov Cap-2 Maneuver	401	-	-	-	-	-
Stage 1	735	-	-	-	-	-
Stage 2	671	-	-	-	-	-

Approach	WB	NB	SB
HCM Control Delay, s	12.8	0	2.4
HCM LOS	B		

Minor Lane/Major Mvmt	NBT	NBRWBLn1	SBL	SBT
Capacity (veh/h)	-	-	589	1228
HCM Lane V/C Ratio	-	-	0.221	0.063
HCM Control Delay (s)	-	-	12.8	8.1
HCM Lane LOS	-	-	B	A
HCM 95th %tile Q(veh)	-	-	0.8	0.2

Intersection						
Int Delay, s/veh	0.2					
Movement	EBT	EBR	WBL	WBT	NBL	NBR
Lane Configurations	↑↑		↖	↑↑	↘	
Traffic Vol, veh/h	610	7	12	645	4	7
Future Vol, veh/h	610	7	12	645	4	7
Conflicting Peds, #/hr	0	0	0	0	0	0
Sign Control	Free	Free	Free	Free	Stop	Stop
RT Channelized	-	None	-	None	-	None
Storage Length	-	-	0	-	0	-
Veh in Median Storage, #	0	-	-	0	0	-
Grade, %	0	-	-	0	0	-
Peak Hour Factor	92	92	92	92	92	92
Heavy Vehicles, %	2	2	2	2	2	2
Mvmt Flow	663	8	13	701	4	8

Major/Minor	Major1	Major2	Minor1	Minor2	Minor3
Conflicting Flow All	0	0	671	0	1044
Stage 1	-	-	-	-	667
Stage 2	-	-	-	-	377
Critical Hdwy	-	-	4.14	-	6.84
Critical Hdwy Stg 1	-	-	-	-	5.84
Critical Hdwy Stg 2	-	-	-	-	5.84
Follow-up Hdwy	-	-	2.22	-	3.52
Pot Cap-1 Maneuver	-	-	915	-	225
Stage 1	-	-	-	-	472
Stage 2	-	-	-	-	663
Platoon blocked, %	-	-	-	-	-
Mov Cap-1 Maneuver	-	-	915	-	222
Mov Cap-2 Maneuver	-	-	-	-	222
Stage 1	-	-	-	-	472
Stage 2	-	-	-	-	654

Approach	EB	WB	NB
HCM Control Delay, s	0	0.2	14.7
HCM LOS			B

Minor Lane/Major Mvmt	NBLn1	EBT	EBR	WBL	WBT
Capacity (veh/h)	384	-	-	915	-
HCM Lane V/C Ratio	0.031	-	-	0.014	-
HCM Control Delay (s)	14.7	-	-	9	-
HCM Lane LOS	B	-	-	A	-
HCM 95th %tile Q(veh)	0.1	-	-	0	-

WSDOT Exhibit C List

LIST OF PROGRAMMED
WSDOT PROJECTS IN
SNOHOMISH COUNTY
AS OF Nov. 2008

County ID#	TSA	SR	MP1	MP2	Title/Description	Design/Construction year	Total Cost (M)	TOTAL CAPACITY (ADT)	PRESENT VOLUME	RESERVE CAPACITY (ADT)	TRUE CONTRIBUTION PER ADT	50% TRIP END DEDUCTION	TAX DEDUCTION	Proportionate Share Per Development Generated ADT
DOT-11	D	5	186.42	186.42	128th ST SW Interchange - Construct Loop Ramps / HOV Bypass	2014	\$13.30	99,000	65,000	34,000	\$391.18	\$195.15	\$40.98	\$154.17
DOT-01	A	5	205.85	205.85	172nd Street NE (SR 531) interchange improvements, SB loop ramp, bridge widening	2009	\$41.00	90,000	34,900	55,100	\$744.10	\$372.05	\$63.25	\$308.80
DOT-30	E	9	1.66	4.04	212th Street SE to 176th Street SE, widen to 5 lanes	2011	\$80.80	54,000	21,000	33,000	2,448.48	\$1,224.24	\$183.64	\$1,040.60
DOT-56	B	9	16.48	17.49	Lundeen Parkway to SR-92, Widen to 4 lanes & RT-LT lanes	2009	\$38.90	54,000	24,000	30,000	\$1,296.67	\$648.34	\$123.18	\$525.16
DOT-37	B	9	17.96	17.96	SR-9 at 60th Street NE, add LT & RT lanes at Tee intersection	2011	\$2.95	54,000	36,000	18,000	\$163.89	\$81.95	\$13.91	\$67.94
DOT-22	A	9	18.88	19.46	SR 9/SR 528 intersection improvements, Signal & Channelization	2010	\$17.13	54,000	36,000	18,000	\$951.67	\$475.83	\$80.89	\$394.94
DOT-57	A	9	20.51	20.59	SR-9/84th Street NE intersection improvements, LT & RT lanes	2011	\$17.13	54,000	12,000	42,000	\$407.88	\$203.93	\$55.06	\$148.87
DOT-58	A	9	26.00	26.09	SR-9/SR-531/172nd St. NE intersection improvement, Roundabout	2011	\$15.60	54,000	11,000	43,000	\$362.80	\$181.40	\$45.87	\$135.53
DOT-33	B	92	1.46	1.46	SR-92 at 113th Avenue NE, Roundabout	2009	\$2.36	54,000	19,600	34,000	\$68.60	\$34.30	\$6.52	\$27.78
DOT-31	B	92	1.73	1.73	SR-92 at Callow/Grade Road, turn lanes to SR-92	2009	\$1.90	54,000	19,600	34,400	\$55.24	\$27.62	\$5.25	\$22.37
DOT-46	C	203	22.36	22.38	SR-203 at North High Rock/Tualco Roads, Re-align cross street for I/S and add LT & RT lanes on SR-203	2009	\$3.34	18,000	13,000	5,000	\$688.00	\$344.00	\$73.48	\$270.52
DOT-36	C	203	23.01	23.01	Ben Howard Rd channelization, LT lanes on SR-203	2009	\$1.07	54,000	13,000	41,000	\$26.10	\$13.05	\$2.87	\$10.18
DOT-16	E	522	13.82	16.61	Paradise Lake Road I/C, Stage 3, new interchange	2010	\$27.95	81,000	48,000	33,000	\$847.03	\$423.52	\$63.53	\$359.99
DOT-17	E	522	16.80	20.41	Paradise Lake Road to Snohomish River, Bridge, Stage 2, widen to 4 lanes	2009	\$33.48	80,000	21,900	58,100	\$576.25	\$288.13	\$43.22	\$244.91
DOT-28	C	522	20.50	24.68	Snohomish River Bridge to SR 2, widen to 4 lanes	2010	\$171.98	80,000	20,000	60,000	\$2,866.33	\$1,433.17	\$315.30	\$1,117.87

LIST OF PROGRAMMED
WSDOT PROJECTS IN
SNOHOMISH COUNTY
AS OF Nov. 2008

County ID#	TSA SR	MP1	MP2	Title/Description	Design/Construction year	Total Cost (M)	TOTAL CAPACITY (ADT)	PRESENT VOLUME	RESERVE CAPACITY (ADT)	TRUE CONTRIBUTION PER ADT	50% TRIP END DEDUCTION	TAX DEDUCTION	Proportionate Share Per Development Generated ADT
DOT-19	F 524	5.87	9.50	24th Avenue SE to I-405, widen to 5 Lanes	2012	\$33.34	54,000	15,300	38,700	\$861.50	\$430.75	\$77.54	\$353.21
DOT-20	F 524	5.87	9.50	I-405 to Royal Ann Road, widen to 5 Lanes	2011	\$71.06	54,000	15,300	38,700	\$1,836.18	\$918.09	\$165.26	\$752.83
DOT-60	E 524	6.79	6.79	Larch Way intersection, LT lanes, signal	2009	\$2.59	54,000	15,300	38,700	\$66.93	\$33.47	\$5.02	\$28.45
DOT-59	D 525	6.25	6.25	SR-525/68th St. SW intersection improvements, NBRT, NBLT & SBLT	2011	\$3.70	25,700	17,000	8,700	\$425.29	\$212.64	\$89.31	\$123.33
DOT-49	A 530	17.30	17.30	SR-530 at Old 99, Roundabout	2011	\$8.00	18,000	10,000	8,000	\$1,000.00	\$500.00	\$85.00	\$415.00
DOT-62	A 530	19.71	19.71	211th Place NE, Intersection Roundabout	2011	\$6.10	24,000	15,000	9,000	\$677.78	\$338.89	\$57.61	\$281.28
DOT-52	A 531	1.95	2.25	SR-531/Jct. Freestad Road Intersection, LT lanes	2011	\$1.55	18,000	7,900	10,100	\$140.14	\$70.07	\$11.92	\$58.15
DOT-05	A 531	7.00	8.59	43rd Ave. NE to 67th Ave. NE, NE, Widen to 5 lanes (Arlington)	2014	\$20.78	54,000	11,000	43,000	\$483.14	\$241.57	\$41.07	\$200.50
				270th St. NW Vic. To 72nd Ave. NW, EB Climbing Lane, intersection improvements & signal.	2009	\$19.00	54,000	16,000	38,000	500	\$250.00	\$28.75	\$221.25
DOT-53	A 532	5.25	5.90	64th Ave. NW to 12th Ave. NW, Climbing lane & LT Lanes	2010	\$22.40	54,000	17,000	37,000	\$605.41	\$302.70	\$33.75	\$268.95
				TAX DEDUCTIONS									
				TSA A = 17%									
				TSA B = 19%									
				TSA C = 22%									
				TSA D = 21%									
				TSA E = 15%									
				TSA F = 18%									

Legend

- Thru Movement
- Left-Turn Movement
- Right-Turn Movement

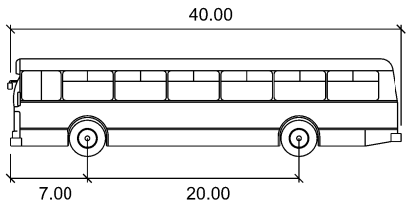
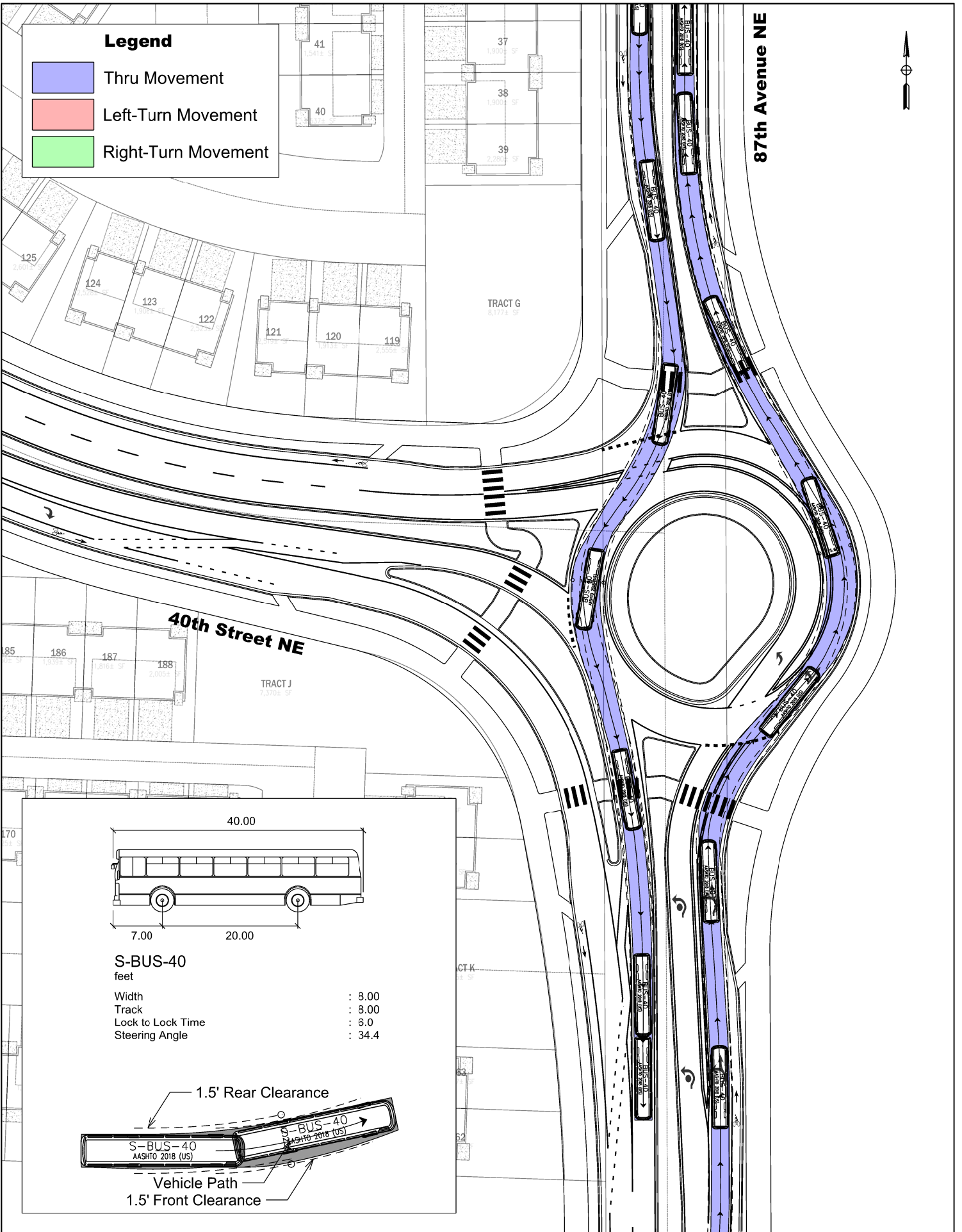

S-BUS-40
feet

Width	: 8.00
Track	: 8.00
Lock to Lock Time	: 6.0
Steering Angle	: 34.4

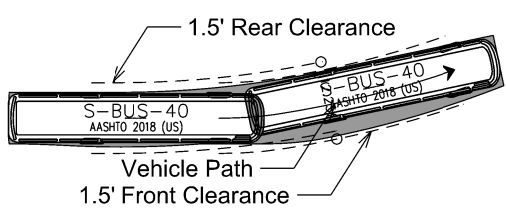

Legend

- Thru Movement
- Left-Turn Movement
- Right-Turn Movement

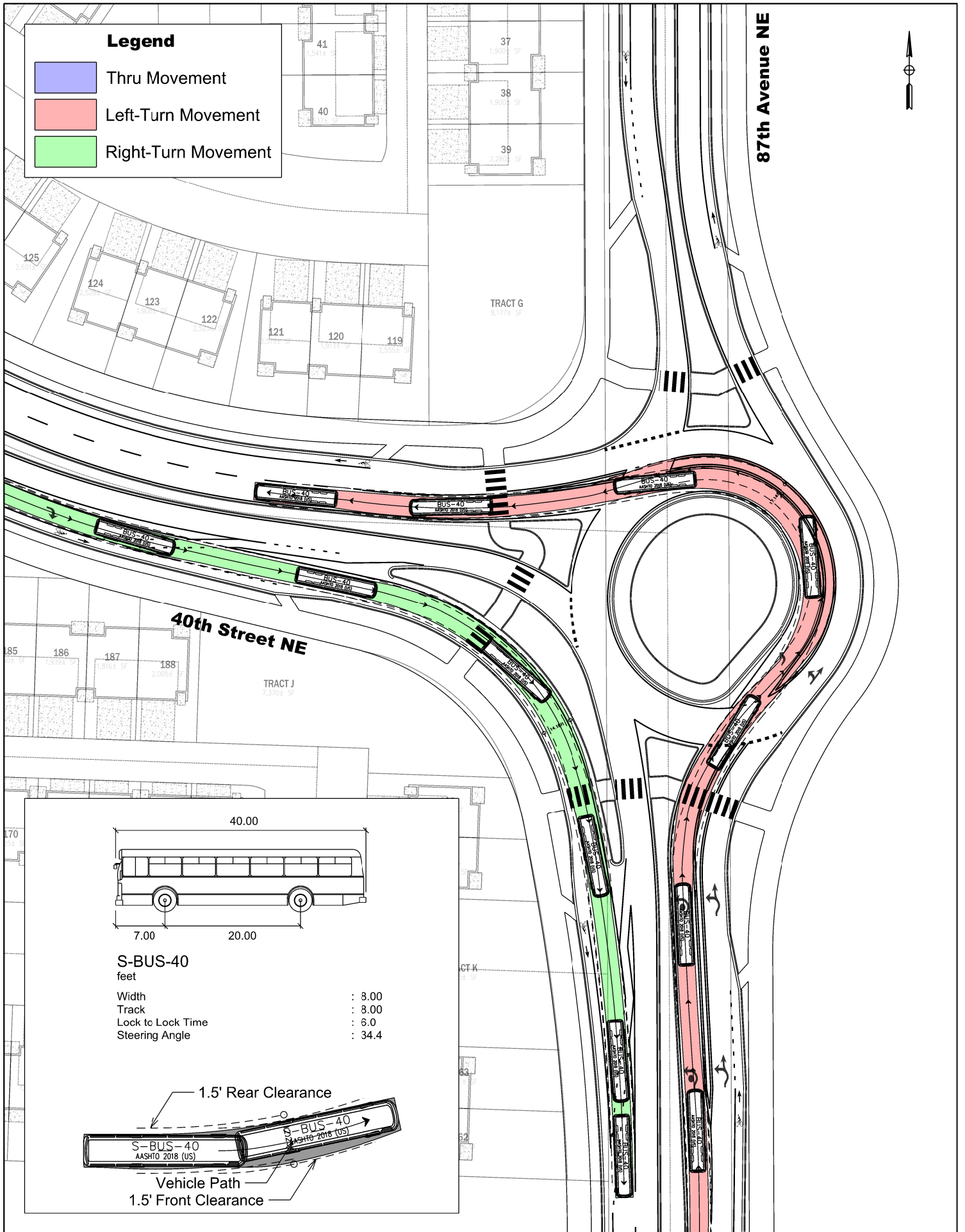

Legend

- Thru Movement
- Left-Turn Movement
- Right-Turn Movement

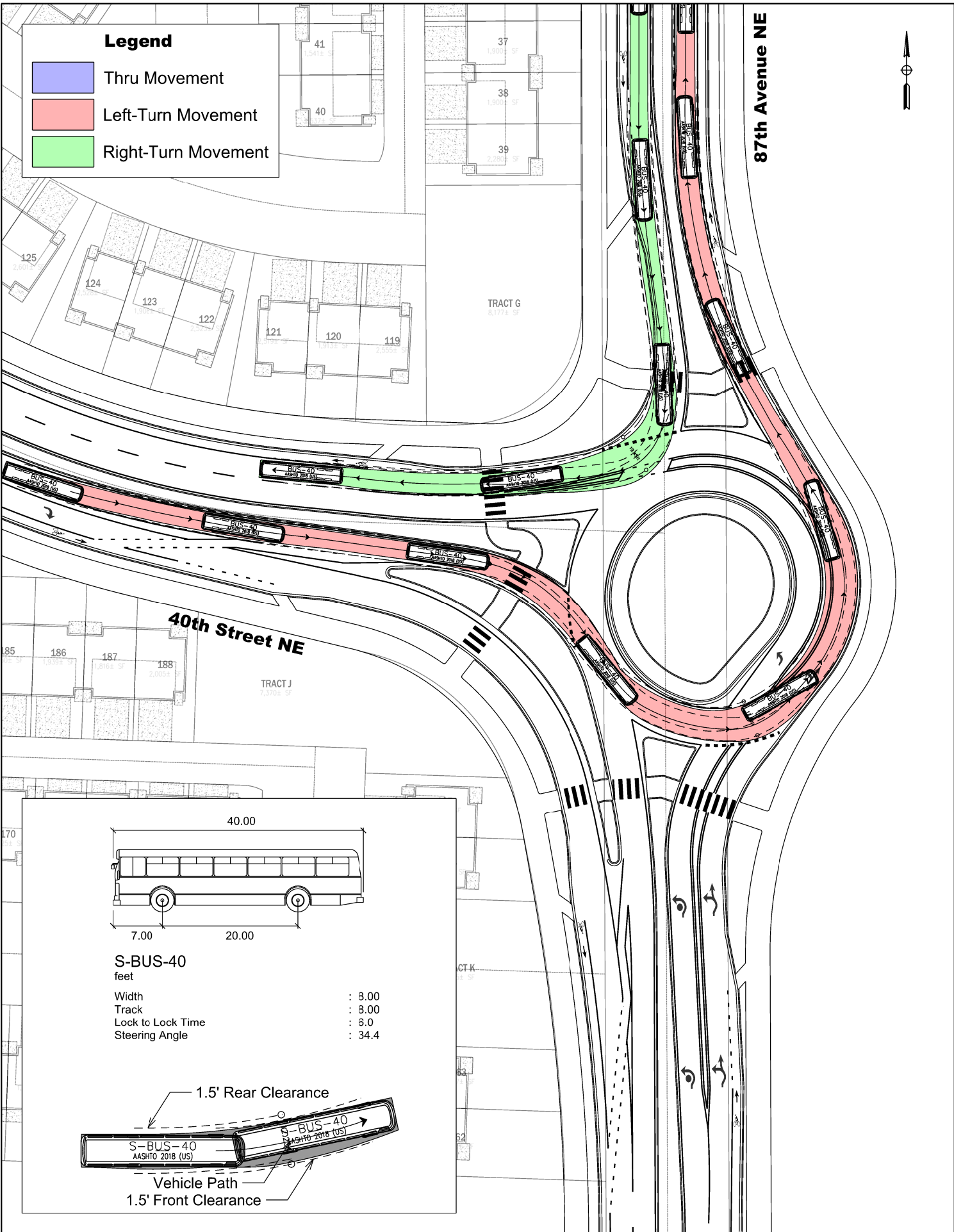

Legend

- Thru Movement
- Left-Turn Movement
- Right-Turn Movement

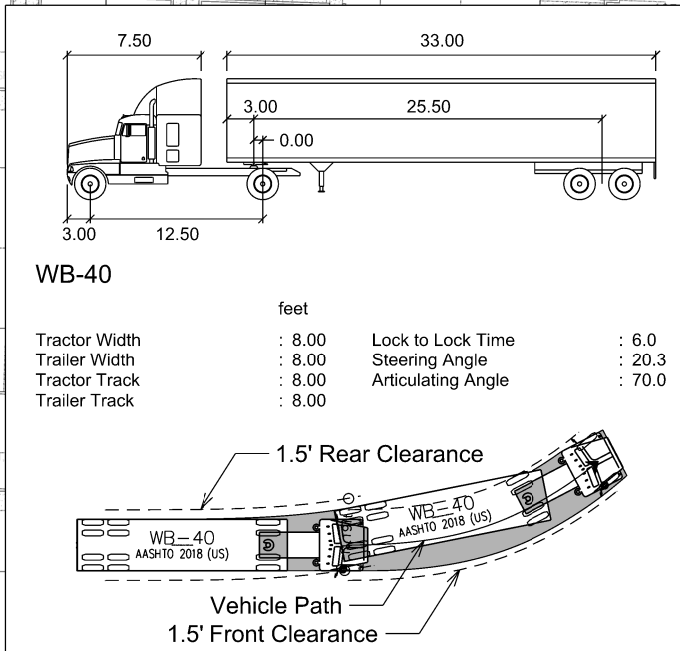
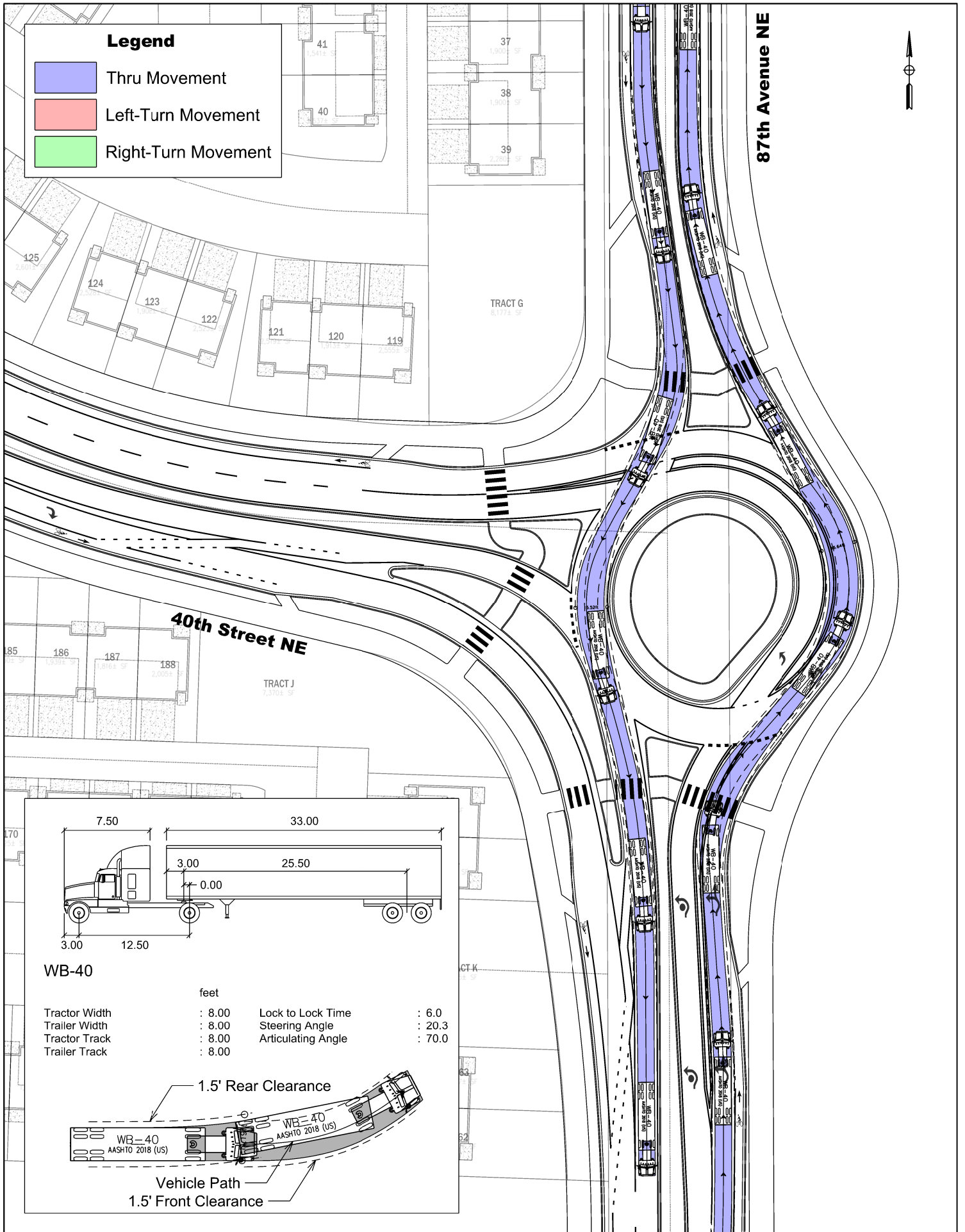

Legend

- Thru Movement
- Left-Turn Movement
- Right-Turn Movement

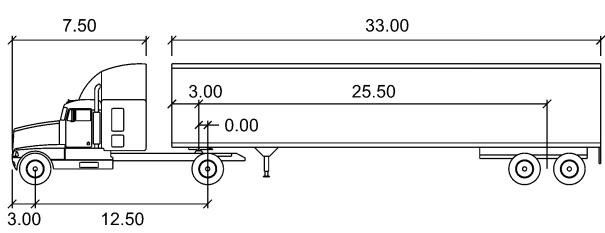
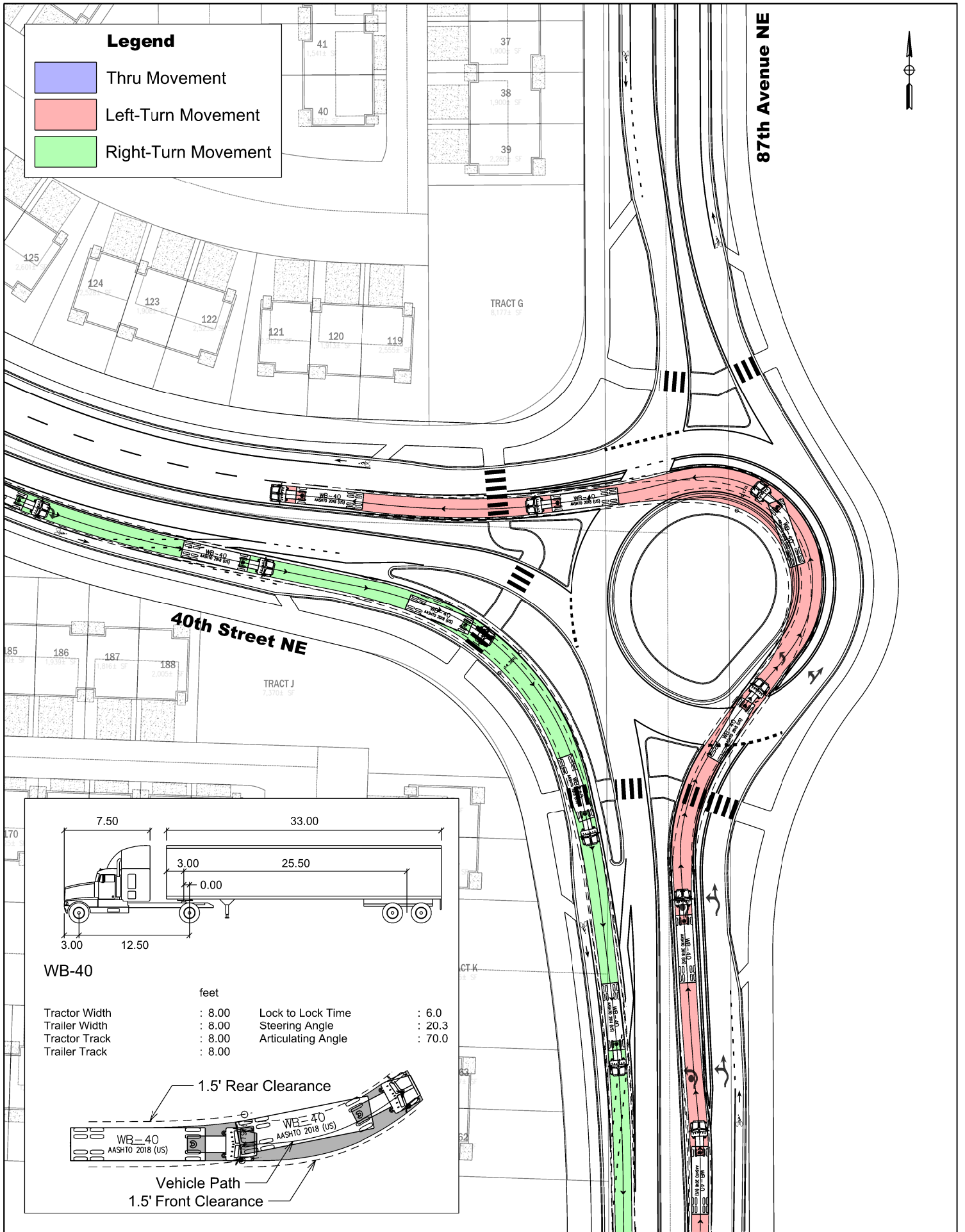

WB-40

feet

Tractor Width	: 8.00	Lock to Lock Time	: 6.0
Trailer Width	: 8.00	Steering Angle	: 20.3
Tractor Track	: 8.00	Articulating Angle	: 70.0
Trailer Track	: 8.00		

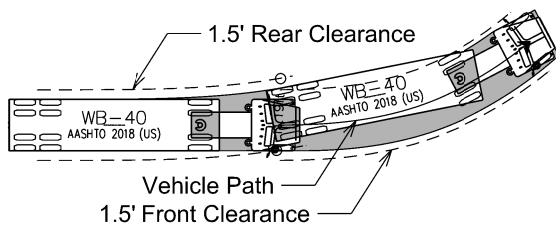

Legend

- Thru Movement
- Left-Turn Movement
- Right-Turn Movement

