

**City of Marysville
Marysville, Washington**



SPECIAL PROVISIONS

for

LAKWOOD STATION/SR 531 ROUNDABOUT

Project Number: 25-2015-002
July 2015

CITY OF MARYSVILLE, WASHINGTON
LAKEWOOD STATION/SR 531 ROUNDABOUT

The engineering material and data contained in these Contract Provisions were prepared under the supervision and direction of the undersigned, whose seal as a registered professional engineer is affixed below.



Randa Kiriakos, P.E.
Project Engineer

The City of Marysville, has reviewed and approved these Special Provisions and the Contract Plans dated 7/6/15, and they are authorized for issue.

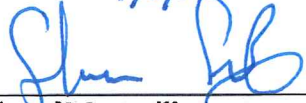

City of Marysville

7/6/15

Date



This Page Intentionally Left Blank

Table of Content

INTRODUCTION TO THE SPECIAL PROVISIONS	1
DIVISION 1 GENERAL REQUIREMENTS	3
DESCRIPTION OF WORK	3
1-01 DEFINITIONS AND TERMS.....	3
1-04 SCOPE OF THE WORK	5
1-05 CONTROL OF WORK	6
1-07 LEGAL RELATIONS AND RESPONSIBILITIES TO THE PUBLIC	15
1-08 PROSECUTION AND PROGRESS	20
1-10 TEMPORARY TRAFFIC CONTROL.....	22
DIVISION 2 EARTHWORK	27
2-01 CLEARING, GRUBBING, AND ROADSIDE CLEANUP.....	27
2-02 REMOVAL OF STRUCTURES AND OBSTRUCTIONS	27
2-03 ROADWAY EXCAVATION AND EMBANKMENT.....	29
2-05 PAVEMENT PULVERIZING (NEW SECTION).....	30
DIVISION 5 SURFACE TREATMENTS AND PAVEMENTS	31
5-04 HOT MIX ASPHALT.....	31
5-05 CEMENT CONCRETE PAVEMENT	33
DIVISION 7 DRAINAGE STRUCTURES, STORM SEWERS, SANITARY SEWERS, WATER MAINS AND CONDUITS	37
7-04 STORM SEWERS.....	37
7-12 VALVES FOR WATER MAINS 7-12.3 CONSTRUCTION REQUIREMENTS	37
7-17 SANITARY SEWERS.....	37
DIVISION 8 MISCELLANEOUS CONSTRUCTION	39
8-01 EROSION CONTROL AND WATER POLLUTION CONTROL	39
8-02 ROADSIDE RESTORATION.....	41
8-04 CURB, GUTTERS, AND SPILLWAYS	45
8-06 CEMENT CONCRETE DRIVEWAY ENTRANCES	46
8-14 CEMENT CONCRETE SIDEWALKS	47
8-20A ILLUMINATION, TRAFFIC SIGNAL SYSTEMS, AND ELECTRICAL - SIGNAL MODIFICATION ONLY.....	47
8-20B ILLUMINATION, TRAFFIC SIGNAL SYSTEMS, AND ELECTRICAL - ILLUMINATION SYSTEM ONLY	71
8-21 PERMANENT SIGNING.....	81
8-22 PAVEMENT MARKING.....	83
DIVISION 9 MATERIALS	85
9-03 AGGREGATES.....	85
9-15 IRRIGATION SYSTEM	86
9-28 SIGNING MATERIALS AND FABRICATION	86
9-29 ILLUMINATION, SIGNAL, AND ELECTRICAL.....	87

APPENDICES

- A. AMENDMENTS TO THE STANDARD SPECIFICATIONS
- B. STANDARD PLANS

This Page Intentionally Left Blank

1

1
2

**DIVISION 1
GENERAL REQUIREMENTS**

3 **DESCRIPTION OF WORK**

4 *(March 13, 1995 WSDOT GSP)*

5 This contract provides for the construction of a roundabout at the intersection of SR 531 and
6 23rd Avenue NE. The work to be performed includes, but is not limited to: illumination,
7 landscaping, colored stamped concrete paving, hot mix asphalt, curb, gutter, sidewalk, storm
8 drainage, striping, signing, temporary erosion and sedimentation control, temporary traffic
9 control, and roadway surveying necessary to complete the project in the City of Marysville,
10 Snohomish County, Washington, and other work, all in accordance with the Contract
11 Documents.

12 **1-01 DEFINITIONS AND TERMS**

13 **1-01.3 Definitions**

14 *(March 8, 2013 APWA GSP)*

15 Delete the heading Completion Dates and the three paragraphs that follow it, and replace
16 them with the following:

17
18 **Dates**

19 ***Bid Opening Date***

20 The date on which the Contracting Agency publicly opens and reads the Bids.

21 ***Award Date***

22 The date of the formal decision of the Contracting Agency to accept the lowest
23 responsible and responsive Bidder for the Work.

24 ***Contract Execution Date***

25 The date the Contracting Agency officially binds the Agency to the Contract.

26 ***Notice to Proceed Date***

27 The date stated in the Notice to Proceed on which the Contract time begins.

28 ***Substantial Completion Date***

29 The day the Engineer determines the Contracting Agency has full and unrestricted use
30 and benefit of the facilities, both from the operational and safety standpoint, any
31 remaining traffic disruptions will be rare and brief, and only minor incidental work,
32 replacement of temporary substitute facilities, plant establishment periods, or correction
33 or repair remains for the Physical Completion of the total Contract.

1 ***Physical Completion Date***

2 The day all of the Work is physically completed on the project. All documentation
3 required by the Contract and required by law does not necessarily need to be furnished
4 by the Contractor by this date.

5 ***Completion Date***

6 The day all the Work specified in the Contract is completed and all the obligations of
7 the Contractor under the Contract are fulfilled by the Contractor. All documentation
8 required by the Contract and required by law must be furnished by the Contractor
9 before establishment of this date.

10 ***Final Acceptance Date***

11 The date on which the Contracting Agency accepts the Work as complete.

12
13 Supplement this Section with the following:

14
15 All references in the Standard Specifications, Amendments, or WSDOT General Special
16 Provisions, to the terms “State”, “Department of Transportation”, “Washington State
17 Transportation Commission”, “Commission”, “Secretary of Transportation”,
18 “Secretary”, “Headquarters”, and “State Treasurer” shall be revised to read “Contracting
19 Agency”.

20
21 All references to “State Materials Laboratory” shall be revised to read, “Contracting
22 Agency designated location”.

23
24 All references to “final contract voucher certification” shall be interpreted to mean the
25 final payment form established by the Contracting Agency.

26
27 The venue of all causes of action arising from the advertisement, award, execution, and
28 performance of the contract shall be in the Superior Court of the County where the
29 Contracting Agency’s headquarters are located.

30
31 **Additive**

32 A supplemental unit of work or group of bid items, identified separately in the Bid Proposal,
33 which may, at the discretion of the Contracting Agency, be awarded in addition to the base
34 bid.

35
36 **Alternate**

37 One of two or more units of work or groups of bid items, identified separately in the Bid
38 Proposal, from which the Contracting Agency may make a choice between different
39 methods or material of construction for performing the same work.

40
41 **Business Day**

42 A business day is any day from Monday through Friday except holidays as listed in
43 Section 1-08.5.

1 **Contract Bond**

2 The definition in the Standard Specifications for “Contract Bond” applies to whatever bond
3 form(s) are required by the Contract Documents, which may be a combination of a Payment
4 Bond and a Performance Bond.

5
6 **Contract Documents**

7 See definition for “Contract”.

8
9 **Contract Time**

10 The period of time established by the terms and conditions of the Contract within which the
11 Work must be physically completed.

12
13 **Engineer**

14 The Contracting Agency’s representative who administers the construction program for the
15 Contracting Agency or the Contracting Agency representative’s designee.

16
17 **Notice of Award**

18 The written notice from the Contracting Agency to the successful Bidder signifying the
19 Contracting Agency’s acceptance of the Bid Proposal.

20
21 **Notice to Proceed**

22 The written notice from the Contracting Agency or Engineer to the Contractor authorizing
23 and directing the Contractor to proceed with the Work and establishing the date on which the
24 Contract time begins.

25
26 **Traffic**

27 Both vehicular and non-vehicular traffic, such as pedestrians, bicyclists, wheelchairs, and
28 equestrian traffic.

29 **1-04 SCOPE OF THE WORK**

30 **1-04.2 Coordination of Contract Documents, Plans, Special Provisions, Specifications,**
31 **and Addenda**

32 *(March 13, 2012 APWA GSP)*

33 Revise the second paragraph to read:

34
35 Any inconsistency in the parts of the contract shall be resolved by following this order of
36 precedence (e.g., 1 presiding over 2, 2 over 3, 3 over 4, and so forth):

- 37
38 1. Addenda,
39 2. Proposal Form,

- 1 3. Special Provisions,
- 2 4. Contract Plans,
- 3 5. April 11, 2014 Amendments to the Standard Specifications,
- 4 6. Standard Specifications,
- 5 7. Contracting Agency's Standard Plans or Details (if any), and
- 6 8. 2014 WSDOT Standard Plans for Road, Bridge, and Municipal Construction.

7 **1-05 CONTROL OF WORK**

8 **1-05.4 Conformity With and Deviations from Plans and Stakes**

9 Section 1-5.4 is supplemented with the following:

10 *(April 1, 2013 WSDOT GSP)*

11 **Contractor Surveying - Roadway**

12 Copies of the Contracting Agency provided primary survey control data are available for
13 the bidder's inspection at the office of the Engineer.

14

15 The Contractor shall be responsible for setting, maintaining, and resetting all alignment
16 stakes, slope stakes, and grades necessary for the construction of the roadbed, drainage,
17 surfacing, paving, channelization and pavement marking, illumination and signals,
18 guardrails and barriers, and signing. Except for the survey control data to be furnished
19 by the Contracting Agency, calculations, surveying, and measuring required for setting
20 and maintaining the necessary lines and grades shall be the Contractor's responsibility.

21

22 The Contractor shall inform the Engineer when monuments are discovered that were not
23 identified in the Plans and construction activity may disturb or damage the monuments.
24 All monuments noted on the Plans "DO NOT DISTURB" shall be protected throughout
25 the length of the project or be replaced at the Contractors expense.

26

27 Detailed survey records shall be maintained, including a description of the work
28 performed on each shift, the methods utilized, and the control points used. The record
29 shall be adequate to allow the survey to be reproduced. A copy of each day's record shall
30 be provided to the Engineer within three working days after the end of the shift.

31

32 The meaning of words and terms used in this provision shall be as listed in "Definitions
33 of Surveying and Associated Terms" current edition, published by the American
34 Congress on Surveying and Mapping and the American Society of Civil Engineers.

35

36 The survey work shall include but not be limited to the following:

37

- 38 1. Verify the primary horizontal and vertical control furnished by the Contracting
39 Agency, and expand into secondary control by adding stakes and hubs as well as
40 additional survey control needed for the project. Provide descriptions of secondary

1 control to the Contracting Agency. The description shall include coordinates and
2 elevations of all secondary control points.

3 2. Establish, the centerlines of all alignments, by placing hubs, stakes, or marks on
4 centerline or on offsets to centerline at all curve points (PCs, PTs, and PIs) and at
5 points on the alignments spaced no further than 50 feet.

6 3. Establish clearing limits, placing stakes at all angle points and at intermediate
7 points not more than 50 feet apart. The clearing and grubbing limits shall be 5 feet
8 beyond the toe of a fill and 10 feet beyond the top of a cut unless otherwise shown
9 in the Plans.

10 4. Establish grading limits, placing slope stakes at centerline increments not more
11 than 50 feet apart. Establish offset reference to all slope stakes. If Global
12 Positioning Satellite (GPS) Machine Controls are used to provide grade control,
13 then slope stakes may be omitted at the discretion of the Contractor

14 5. Establish the horizontal and vertical location of all drainage features, placing offset
15 stakes to all drainage structures and to pipes at a horizontal interval not greater than
16 25 feet.

17 6. Establish roadbed and surfacing elevations by placing stakes at the top of subgrade
18 and at the top of each course of surfacing. Subgrade and surfacing stakes shall be
19 set at horizontal intervals not greater than 50 feet in tangent sections, 25 feet in
20 curve sections with a radius less than 300 feet, and at 10-foot intervals in
21 intersection radii with a radius less than 10 feet. Transversely, stakes shall be
22 placed at all locations where the roadway slope changes and at additional points
23 such that the transverse spacing of stakes is not more than 12 feet. If GPS Machine
24 Controls are used to provide grade control, then roadbed and surfacing stakes may
25 be omitted at the discretion of the Contractor.

26 7. Establish intermediate elevation benchmarks as needed to check work throughout
27 the project.

28 8. Provide references for paving pins at 25-foot intervals or provide simultaneous
29 surveying to establish location and elevation of paving pins as they are being
30 placed.

31 9. For all other types of construction included in this provision, (including but not
32 limited to channelization and pavement marking, illumination and signals,
33 guardrails and barriers, and signing) provide staking and layout as necessary to
34 adequately locate, construct, and check the specific construction activity.

35 10. Contractor shall determine if changes are needed to the profiles or roadway
36 sections shown in the Contract Plans in order to achieve proper smoothness and
37 drainage where matching into existing features, such as a smooth transition from
38 new pavement to existing pavement. The Contractor shall submit these changes to
39 the Engineer for review and approval 10 days prior to the beginning of work.

40
41 The Contractor shall provide the Contracting Agency copies of any calculations and
42 staking data when requested by the Engineer.

43
44 To facilitate the establishment of these lines and elevations, the Contracting Agency will
45 provide the Contractor with primary survey control information consisting of
46 descriptions of two primary control points used for the horizontal and vertical control,

1 and descriptions of two additional primary control points for every additional three miles
 2 of project length. Primary control points will be described by reference to the project
 3 alignment and the coordinate system and elevation datum utilized by the project. In
 4 addition, the Contracting Agency will supply horizontal coordinates for the beginning
 5 and ending points and for each Point of Intersection (PI) on each alignment included in
 6 the project.

7
 8 The Contractor shall ensure a surveying accuracy within the following tolerances:

	<u>Vertical</u>	<u>Horizontal</u>
10 Slope stakes	±0.10 feet	±0.10 feet
11 Subgrade grade stakes set		
12 0.04 feet below grade	±0.01 feet	±0.5 feet
13		(parallel to alignment)
14		±0.1 feet
15		(normal to alignment)
16		
17 Stationing on roadway	N/A	±0.1 feet
18 Alignment on roadway	N/A	±0.04 feet
19 Surfacing grade stakes	±0.01 feet	±0.5 feet
20		(parallel to alignment)
21		±0.1 feet
22		(normal to alignment)
23		
24 Roadway paving pins for		
25 surfacing or paving	±0.01 feet	±0.2 feet
26		(parallel to alignment)
27		±0.1 feet
28		(normal to alignment)
29		
30		

31 The Contracting Agency may spot-check the Contractor's surveying. These spot-checks
 32 will not change the requirements for normal checking by the Contractor.

33
 34 When staking roadway alignment and stationing, the Contractor shall perform
 35 independent checks from different secondary control to ensure that the points staked are
 36 within the specified survey accuracy tolerances.

37
 38 The Contractor shall calculate coordinates for the alignment. The Contracting Agency
 39 will verify these coordinates prior to issuing approval to the Contractor for commencing
 40 with the work. The Contracting Agency will require up to seven calendar days from the
 41 date the data is received.

42
 43 Contract work to be performed using contractor-provided stakes shall not begin until the
 44 stakes are approved by the Contracting Agency. Such approval shall not relieve the
 45 Contractor of responsibility for the accuracy of the stakes.

46

1 Stakes shall be marked in accordance with WSDOT Standard Plan A-10.10-00. When
2 stakes are needed that are not described in the Plans, then those stakes shall be marked,
3 at no additional cost to the Contracting Agency as ordered by the Engineer.

4 **1-05.7 Removal of Defective and Unauthorized Work**

5 *(October 1, 2005 APWA GSP)*

6 Supplement this section with the following:

7

8 If the Contractor fails to remedy defective or unauthorized work within the time
9 specified in a written notice from the Engineer, or fails to perform any part of the work
10 required by the Contract Documents, the Engineer may correct and remedy such work as
11 may be identified in the written notice, with Contracting Agency forces or by such other
12 means as the Contracting Agency may deem necessary.

13

14 If the Contractor fails to comply with a written order to remedy what the Engineer
15 determines to be an emergency situation, the Engineer may have the defective and
16 unauthorized work corrected immediately, have the rejected work removed and replaced,
17 or have work the Contractor refuses to perform completed by using Contracting Agency
18 or other forces. An emergency situation is any situation when, in the opinion of the
19 Engineer, a delay in its remedy could be potentially unsafe or might cause serious risk of
20 loss or damage to the public.

21

22 Direct or indirect costs incurred by the Contracting Agency attributable to correcting and
23 remedying defective or unauthorized work, or work the Contractor failed or refused to
24 perform, shall be paid by the Contractor. Payment will be deducted by the Engineer
25 from monies due, or to become due, the Contractor. Such direct and indirect costs shall
26 include in particular, but without limitation, compensation for additional professional
27 services required, and costs for repair and replacement of work of others destroyed or
28 damaged by correction, removal, or replacement of the Contractor's unauthorized work.

29

30 No adjustment in contract time or compensation will be allowed because of the delay in
31 the performance of the work attributable to the exercise of the Contracting Agency's
32 rights provided by this Section.

33

34 The rights exercised under the provisions of this section shall not diminish the
35 Contracting Agency's right to pursue any other avenue for additional remedy or damages
36 with respect to the Contractor's failure to perform the work as required.

37 **1-05.11 Final Inspection**

38 *(October 1, 2005 APWA GSP)*

39 Delete this section and replace it with the following:

1 **1-05.11 Final Inspections and Operational Testing**

2 **1-05.11(1) Substantial Completion Date**

3 When the Contractor considers the work to be substantially complete, the Contractor
4 shall so notify the Engineer and request the Engineer establish the Substantial
5 Completion Date. The Contractor’s request shall list the specific items of work that
6 remain to be completed in order to reach physical completion. The Engineer will
7 schedule an inspection of the work with the Contractor to determine the status of
8 completion. The Engineer may also establish the Substantial Completion Date
9 unilaterally.

10
11 If, after this inspection, the Engineer concurs with the Contractor that the work is
12 substantially complete and ready for its intended use, the Engineer, by written notice to
13 the Contractor, will set the Substantial Completion Date. If, after this inspection the
14 Engineer does not consider the work substantially complete and ready for its intended
15 use, the Engineer will, by written notice, so notify the Contractor giving the reasons
16 therefore.

17
18 Upon receipt of written notice concurring in or denying substantial completion,
19 whichever is applicable, the Contractor shall pursue vigorously, diligently and without
20 unauthorized interruption, the work necessary to reach Substantial and Physical
21 Completion. The Contractor shall provide the Engineer with a revised schedule
22 indicating when the Contractor expects to reach substantial and physical completion of
23 the work.

24
25 The above process shall be repeated until the Engineer establishes the Substantial
26 Completion Date and the Contractor considers the work physically complete and ready
27 for final inspection.

28 **1-05.11(2) Final Inspection and Physical Completion Date**

29 When the Contractor considers the work physically complete and ready for final
30 inspection, the Contractor by written notice shall request the Engineer to schedule a final
31 inspection. The Engineer will set a date for final inspection. The Engineer and the
32 Contractor will then make a final inspection and the Engineer will notify the Contractor
33 in writing of all particulars in which the final inspection reveals the work incomplete or
34 unacceptable. The Contractor shall immediately take such corrective measures as are
35 necessary to remedy the listed deficiencies. Corrective work shall be pursued
36 vigorously, diligently, and without interruption until physical completion of the listed
37 deficiencies. This process will continue until the Engineer is satisfied the listed
38 deficiencies have been corrected.

39
40 If action to correct the listed deficiencies is not initiated within 7 days after receipt of the
41 written notice listing the deficiencies, the Engineer may, upon written notice to the
42 Contractor, take whatever steps are necessary to correct those deficiencies pursuant to
43 Section 1-05.7.
44

1 Upon correction of all deficiencies, the Engineer will notify the Contractor and the
2 Contracting Agency, in writing, of the date upon which the work was considered
3 physically complete. That date shall constitute the Physical Completion Date of the
4 contract, but shall not imply acceptance of the work or that all the obligations of the
5 Contractor under the contract have been fulfilled.

6 **1-05.11(3) Operational Testing**

7 It is the intent of the Contracting Agency to have at the Physical Completion Date a
8 complete and operable system. Therefore, when the work involves the installation of
9 machinery or other mechanical equipment; street lighting, electrical distribution or signal
10 systems; irrigation systems; buildings; or other similar work it may be desirable for the
11 Engineer to have the Contractor operate and test the work for a period of time after final
12 inspection but prior to the physical completion date. Whenever items of work are listed
13 in the Contract Provisions for operational testing they shall be fully tested under
14 operating conditions for the time period specified to ensure their acceptability prior to
15 the Physical Completion Date. During and following the test period, the Contractor shall
16 correct any items of workmanship, materials, or equipment which prove faulty, or that
17 are not in first class operating condition. Equipment, electrical controls, meters, or other
18 devices and equipment to be tested during this period shall be tested under the
19 observation of the Engineer, so that the Engineer may determine their suitability for the
20 purpose for which they were installed. The Physical Completion Date cannot be
21 established until testing and corrections have been completed to the satisfaction of the
22 Engineer.

23
24 The costs for power, gas, labor, material, supplies, and everything else needed to
25 successfully complete operational testing, shall be included in the unit contract prices
26 related to the system being tested, unless specifically set forth otherwise in the proposal.

27
28 Operational and test periods, when required by the Engineer, shall not affect a
29 manufacturer's guaranties or warranties furnished under the terms of the contract.

30 **1-05.12(1) Two-Year Guarantee Period**

31 (*****)

32 Add the following new section:

33
34 The Contractor shall return to the project and repair or replace all defects in
35 workmanship and material discovered within two year after Final Acceptance of the
36 Work. The Contractor shall start work to remedy any such defects within 7 calendar
37 days of receiving Contracting Agency's written notice of a defect, and shall complete
38 such work within the time stated in the Contracting Agency's notice. In case of an
39 emergency, where damage may result from delay or where loss of services may
40 result, such corrections may be made by the Contracting Agency's own forces or
41 another contractor, in which case the cost of corrections shall be paid by the
42 Contractor. In the event the Contractor does not accomplish corrections within the

1 time specified, the work will be otherwise accomplished and the cost of same shall
2 be paid by the Contractor.

3
4 When corrections of defects are made, the Contractor shall then be responsible for
5 correcting all defects in workmanship and materials in the corrected work for one
6 year after acceptance of the corrections by Contracting Agency.

7
8 This guarantee is supplemental to and does not limit or affect the requirements that
9 the Contractor's work comply with the requirements of the Contract or any other
10 legal rights or remedies of the Contracting Agency.

11 **1-05.13 Superintendents, Labor, and Equipment of Contractor**

12 *(August 14, 2013 APWA GSP)*

13 Delete the sixth and seventh paragraphs of this section.

14 **1-05.14 Cooperation with Other Contractors**

15 *(March 13, 1995 WSDOT GSP)*

16 Section 1-05.14 is supplemented with the following:

17 **Other Contracts or Other Work**

18 It is anticipated that the following work adjacent to or within the limits of this project
19 will be performed by others during the course of this project and will require
20 coordination of the work:

21 **Snohomish County Public Utility District No. 1 (PUD):**

22 Relocation of utility poles and overhead wires as noted on the Site Preparation Plans.
23 This work will occur during the course of the construction.

24 **Frontier:**

25 Replacing existing pedestals with utility vaults. This work will occur during the course of
26 the construction.

27 **Wave Broadband:**

28 Relocate overhead wires per new PUD pole locations.

29 **1-05.15 Method of Serving Notices**

30 *(March 25, 2009 APWA GSP)*

31 Revise the second paragraph to read:

32

1 All correspondence from the Contractor shall be directed to the Engineer. All
2 correspondence from the Contractor constituting any notification, notice of protest,
3 notice of dispute, or other correspondence constituting notification required to be
4 furnished under the Contract, must be in paper format, hand delivered or sent via mail
5 delivery service to the Engineer's office. Electronic copies such as e-mails or
6 electronically delivered copies of correspondence will not constitute such notice and will
7 not comply with the requirements of the Contract.

8
9 Add the following new section:

10 **1-05.16 Water and Power**

11 *(October 1, 2005 APWA GSP)*

12 The Contractor shall make necessary arrangements, and shall bear the costs for power
13 and water necessary for the performance of the work, unless the contract includes power
14 and water as a pay item.

15
16 Add the following new section:

17 **1-05.17 Oral Agreements**

18 *(October 1, 2005 APWA GSP)*

19 No oral agreement or conversation with any officer, agent, or employee of the
20 Contracting Agency, either before or after execution of the contract, shall affect or
21 modify any of the terms or obligations contained in any of the documents comprising the
22 contract. Such oral agreement or conversation shall be considered as unofficial
23 information and in no way binding upon the Contracting Agency, unless subsequently
24 put in writing and signed by the Contracting Agency.

25
26 Add the following new section:

27 **1-05.18 Record Drawings**

28 *(March 8, 2013 APWA GSP)*

29 The Contractor shall maintain one set of full-size plans for Record Drawings, updated
30 with clear and accurate redlined field revisions on a daily basis, and within two business
31 days after receipt of information that a change in Work has occurred. The Contractor
32 shall not conceal any work until the required information is recorded.

33
34 This Record Drawing set shall be used for this purpose alone, shall be kept separate from
35 other Plan sheets, and shall be clearly marked as Record Drawings. These Record
36 Drawings shall be kept on site at the Contractor's field office, and shall be available for
37 review by the Contracting Agency at all times. The Contractor shall bring the Record
38 Drawings to each progress meeting for review.

1 The preparation and upkeep of the Record Drawings is to be the assigned responsibility
 2 of a single, experienced, and qualified individual. The quality of the Record Drawings,
 3 in terms of accuracy, clarity, and completeness, is to be adequate to allow the
 4 Contracting Agency to modify the computer-aided drafting (CAD) Contract Drawings to
 5 produce a complete set of Record Drawings for the Contracting Agency without further
 6 investigative effort by the Contracting Agency.

7
 8 The Record Drawing markups shall document all changes in the Work, both concealed
 9 and visible. Items that must be shown on the markups include but are not limited to:

- 11 • Actual dimensions, arrangement, and materials used when different than shown
 12 in the Plans.
- 13 • Changes made by Change Order or Field Order.
- 14 • Changes made by the Contractor.
- 15 • Accurate locations of storm sewer, sanitary sewer, water mains and other water
 16 appurtenances, structures, conduits, light standards, vaults, width of roadways,
 17 sidewalks, landscaping areas, building footprints, channelization and pavement
 18 markings, etc. Include pipe invert elevations, top of castings (manholes, inlets,
 19 etc.).

20
 21 If the Contract calls for the Contracting Agency to do all surveying and staking, the
 22 Contracting Agency will provide the elevations at the tolerances the Contracting Agency
 23 requires for the Record Drawings.

24
 25 When the Contract calls for the Contractor to do the surveying/staking, the applicable
 26 tolerance limits include, but are not limited to, the following:

	<u>Vertical</u>	<u>Horizontal</u>
As-built sanitary and storm invert and grate elevations	± 0.01 foot	± 0.01 foot
As-built monumentation	± 0.001 foot	± 0.001 foot
As-built waterlines, inverts, valves, hydrants	± 0.10 foot	± 0.10 foot
As-built ponds/swales/water features	± 0.10 foot	± 0.10 foot
As-built buildings (fin. Floor elev.)	± 0.01 foot	± 0.10 foot
As-built gas lines, power, TV, Tel, Com	± 0.10 foot	± 0.10 foot
As-built signs, signals, etc.	N/A	± 0.10 foot

28
 29
 30 Making Entries on the Record Drawings:

- 31 • Use erasable colored pencil (not ink) for all markings on the Record Drawings,
 32 conforming to the following color code:
- 33 • Additions - Red

- 1 • Deletions - Green
- 2 • Comments - Blue
- 3 • Dimensions - Graphite
- 4 • Provide the applicable reference for all entries, such as the change order number,
- 5 the request for information (RFI) number, or the approved shop drawing number.
- 6 • Date all entries.
- 7 • Clearly identify all items in the entry with notes similar to those in the Contract
- 8 Drawings (such as pipe symbols, centerline elevations, materials, pipe joint
- 9 abbreviations, etc.).

10

11 The Contractor shall certify on the Record Drawings that said drawings are an accurate
12 depiction of built conditions and in conformance with the requirements detailed above.
13 The Contractor shall submit final Record Drawings to the Contracting Agency.
14 Contracting Agency acceptance of the Record Drawings is one of the requirements for
15 achieving Physical Completion.

16 **1-07 LEGAL RELATIONS AND RESPONSIBILITIES TO THE PUBLIC**

17 **1-07.1 Laws to be Observed**

18 *(October 1, 2005 APWA GSP)*

19 Supplement this section with the following:

20

21 In cases of conflict between different safety regulations, the more stringent regulation
22 shall apply.

23

24 The Washington State Department of Labor and Industries shall be the sole and
25 paramount administrative agency responsible for the administration of the provisions of
26 the Washington Industrial Safety and Health Act of 1973 (WISHA).

27

28 The Contractor shall maintain at the project site office, or other well-known place at the
29 project site, all articles necessary for providing first aid to the injured. The Contractor
30 shall establish, publish, and make known to all employees, procedures for ensuring
31 immediate removal to a hospital, or doctor's care, persons, including employees, who
32 may have been injured on the project site. Employees should not be permitted to work
33 on the project site before the Contractor has established and made known procedures for
34 removal of injured persons to a hospital or a doctor's care.

35

36 The Contractor shall have sole responsibility for the safety, efficiency, and adequacy of
37 the Contractor's plant, appliances, and methods, and for any damage or injury resulting
38 from their failure, or improper maintenance, use, or operation. The Contractor shall be
39 solely and completely responsible for the conditions of the project site, including safety
40 for all persons and property in the performance of the work. This requirement shall
41 apply continuously, and not be limited to normal working hours. The required or
42 implied duty of the Engineer to conduct construction review of the Contractor's

1 performance does not, and shall not, be intended to include review and adequacy of the
2 Contractor's safety measures in, on, or near the project site.

3 **1-07.7 Load Limits**

4 *(March 13, 1995 WSDOT GSP)*

5 If the sources of materials provided by the Contractor necessitates hauling over roads
6 other than State Highways, the Contractor shall, at the Contractor's expense, make all
7 arrangements for the use of the haul routes.

8 **1-07.16 Protection and Restoration of Property**

9 **1-07.16(1) Private/Public Property**

10 *(*****)*

11 Section 1-07.16(1) is supplemented with the following:

12 **Survey Monuments**

13 All existing property corner markers shall be protected from movement by the
14 Contractor. All existing markers that must be removed for construction purposes are to
15 be referenced by survey ties and then replaced by a Professional Land Surveyor
16 registered in the State of Washington. All existing property corner markers disturbed or
17 removed by the Contractor's operations which, in the opinion of the Engineer, were not
18 required to be removed for construction purposes shall be replaced at the Contractor's
19 own expense by a Professional Land Surveyor registered in the State of Washington.

20 **1-07.17 Utilities and Similar Facilities**

21 *(April 2, 2007 WSDOT GSP)*

22 Locations and dimensions shown in the Plans for existing facilities are in accordance with
23 available information obtained without uncovering, measuring, or other verification.

24

25 Public and private utilities, or their Contractors, will furnish all work necessary to adjust,
26 relocate, replace, or construct their facilities unless otherwise provided for in the Plans or
27 these Special Provisions. Such adjustment, relocation, replacement, or construction will be
28 done during the prosecution of the work for this project. It is anticipated that utility
29 adjustment, relocation, replacement, or construction within the project limits will be
30 completed as follows:

31 **Snohomish County Public Utility District No. 1 (PUD):**

32 Relocation of utility poles and overhead wires. This work will occur during the course
33 of the construction.

1 **Frontier:**
2 Replacing exiting pedestals with utility vaults. This work will occur during the course of
3 the construction.

4 **Wave Broadband:**

5 Relocate overhead wires per new PUD pole locations.

6
7 The Contractor shall attend a mandatory utility preconstruction meeting with the
8 Engineer, all affected Subcontractors, and all utility owners and their Contractors prior to
9 beginning onsite work.

10
11 The following addresses and telephone numbers of utility companies or their Contractors
12 that will be adjusting, relocating, replacing, or constructing utilities within the project
13 limits are supplied for the Contractor's use:

14 **WSDOT Traffic Signals**

15 Alex Zhang
16 206-440-4419
17 zhangal@wsdot.wa.gov

18
19 Rick Hardin
20 425-339-1777
21 hardinr@wsdot.wa.gov

22 **Snohomish County PUD #1**

23 David Wood
24 425-735-7508
25 dwood@snopud.com

26 **Frontier**

27 Ashley Charouhas
28 Office: 425-261-6282
29 ashley.charouhas@ftr.com

30
31 Herb Autery
32 360-658-2264
33 Herbert.autery@ftr.com

34 **Wave Broadband**

35 Tim Davidson
36 206-391-8679
37 tdavidson@wavebroadband.com

1 **1-07.17(3) Utility Potholing**

(New Section)

2 **1-07.17(3)A Description**

3 The Contractor shall pothole utilities where directed by the Engineer to determine the
4 horizontal and vertical location of existing utilities in advance of the Contractor's
5 operations. Illumination pole locations noted on plan.
6

- 7 • For unidentified utilities found during construction that the Engineer determines
8 may interfere with the Contractor's operation.
- 9 • To provide additional information on utility locations not available during the
10 design of the project at locations identified by the Engineer.
- 11 • At locations identified by the Contractor when determined to be necessary to
12 prevent potential substantial delays in the projects construction and approved by
13 the Engineer.

14
15 The horizontal and vertical locations of potholed utilities shall be shown on the
16 Contractor maintained redlined drawings for the project to a rag tape level of accuracy.

17 **1-07.18 Public Liability and Property Damage Insurance**

18 Delete this section in its entirety, and replace it with the following:

19 **1-07.23 Public Convenience and Safety**

20 **1-07.23(1) Construction under Traffic**

21 Section 1-07.23(1) is supplemented with the following:

22 (*****)

23 **Work Zone Clear Zone**

24 The Work Zone Clear Zone (WZCZ) applies during working and nonworking hours.
25 The WZCZ applies only to temporary roadside objects introduced by the Contractor's
26 operations and does not apply to preexisting conditions or permanent Work. Those work
27 operations that are actively in progress shall be in accordance with adopted and approved
28 Traffic Control Plans, and other contract requirements.
29

30 During nonworking hours, equipment or materials shall not be within the WZCZ unless
31 they are protected by permanent guardrail or temporary concrete barrier. The use of
32 temporary concrete barrier shall be permitted only if the Engineer approves the
33 installation and location.
34

35 During actual hours of work, unless protected as described above, only materials
36 absolutely necessary to construction shall be within the WZCZ and only construction
37 vehicles absolutely necessary to construction shall be allowed within the WZCZ or
38 allowed to stop or park on the shoulder of the roadway.

1
2
3
4
5
6
7
8
9
10
11
12
13
14
15

16
17
18
19
20
21
22
23
24
25
26
27
28
29
30
31
32
33
34
35
36
37
38
39
40
41

The Contractor's nonessential vehicles and employees private vehicles shall not be permitted to park within the WZCZ at any time unless protected as described above.

Deviation from the above requirements shall not occur unless the Contractor has requested the deviation in writing and the Engineer has provided written approval.

The minimum WZCZ distances will be 10 feet from the edge of traveled way.

(*****)

Lane closures are subject to the following restrictions:

1. Two-way traffic must be maintained on SR 531 at all times.
2. Single-lane closures are permitted only between 8:30 am and 2:30 pm.
3. Existing turning movements on SR 531 must be maintained at all times.
4. Emergency, fire, and local access must be maintained at all times.

1-07.24 Rights of Way

*(October 1, 2005 APWA GSP *****)*

Delete this section in its entirety, and replace it with the following:

Street right of way lines, limits of easements, and limits of construction permits are indicated in the Plans. The Contractor's construction activities shall be confined within these limits, unless arrangements for use of private property are made.

Generally, the Contracting Agency will have obtained, prior to bid opening, all rights of way and easements, both permanent and temporary, necessary for carrying out the work. Exceptions to this are noted in the Bid Documents or will be brought to the Contractor's attention by a duly issued Addendum.

Whenever any of the work is accomplished on or through property other than public right of way, the Contractor shall meet and fulfill all covenants and stipulations of any easement agreement obtained by the Contracting Agency from the owner of the private property. Copies of the easement agreements may be included in the Contract Provisions or made available to the Contractor as soon as practical after they have been obtained by the Engineer.

Whenever easements or rights of entry have not been acquired prior to advertising, these areas are so noted in the Plans. The Contractor shall not proceed with any portion of the work in areas where right of way, easements, or rights of entry have not been acquired until the Engineer certifies to the Contractor that the right of way or easement is available or that the right of entry has been received. If the Contractor is delayed due to acts of omission on the part of the Contracting Agency in obtaining easements, rights of

1 entry, or right of way, the Contractor will be entitled to an extension of time. The
2 Contractor agrees that such delay shall not be a breach of contract.

3
4 Each property owner shall be given 48 hours written notice prior to entry by the
5 Contractor. This includes entry onto easements and private property where private
6 improvements must be adjusted.

7
8 The Contractor shall be responsible for providing, without expense or liability to the
9 Contracting Agency, any additional land and access thereto that the Contractor may
10 desire for temporary construction facilities, storage of materials, or other Contractor
11 needs. However, before using any private property, whether adjoining the work or not,
12 the Contractor shall file with the Engineer a written permission of the private property
13 owner, and, upon vacating the premises, a written release from the property owner of
14 each property disturbed or otherwise interfered with by reasons of construction pursued
15 under this contract. The statement shall be signed by the private property owner, or
16 proper authority acting for the owner of the private property affected, stating that
17 permission has been granted to use the property and all necessary permits have been
18 obtained or, in the case of a release, that the restoration of the property has been
19 satisfactorily accomplished. The statement shall include the parcel number, address, and
20 date of signature. Written releases must be filed with the Engineer before the
21 Completion Date will be established.

22 **1-08 PROSECUTION AND PROGRESS**

23 Add the following new section:

24 **1-08.0 Preliminary Matters**

25 *(May 25, 2006 APWA GSP)*

26 Add the following new section:

27 **1-08.0(1) Preconstruction Conference**

28 *(October 10, 2008 APWA GSP)*

29 Prior to the Contractor beginning the work, a preconstruction conference will be held
30 between the Contractor, the Engineer, and such other interested parties as may be
31 invited. The purpose of the preconstruction conference will be:

- 32
- 33 1. To review the initial progress schedule;
 - 34 2. To establish a working understanding among the various parties associated or
35 affected by the work;
 - 36 3. To establish and review procedures for progress payment, notifications,
37 approvals, submittals, etc.;
 - 38 4. To establish normal working hours for the work;
 - 39 5. To review safety standards and traffic control; and
 - 40 6. To discuss such other related items as may be pertinent to the work.

1
2
3
4
5
6
7
8
9
10
11
12
13
14
15
16
17
18
19
20
21
22
23
24
25
26
27
28
29
30
31
32
33
34
35
36
37
38
39
40
41
42
43
44

The Contractor shall prepare and submit at the preconstruction conference the following:

1. A breakdown of all lump sum items;
2. A preliminary schedule of working drawing submittals; and
3. A list of material sources for approval if applicable.

Add the following new section:

1-08.0(2) Hours of Work

(March 8, 2013 APWA GSP)

Except in the case of emergency or unless otherwise approved by the Contracting Agency, the normal straight time working hours for the Contract shall be any consecutive 8-hour period between 7:00 a.m. and 6:00 p.m. of a working day with a maximum 1-hour lunch break and a 5-day work week. The normal straight time 8-hour working period for the Contract shall be established at the preconstruction conference or prior to the Contractor commencing the work.

One-way flagged traffic is allowed between 8:30 a.m. and 2:30 p.m. Two-way traffic must be maintained at all other times. Vehicular traffic will not be allowed to back up to I-5 mainline from the southbound and northbound off-ramps during one-way flagged traffic operations. The Contractor will be required to monitor the ramp traffic and allow westbound SR 531 movements during one-way operations when ramp back-ups exist.

Written permission from the Engineer is required, if a Contractor desires to perform work on holidays, Saturdays, or Sundays; before 7:00 a.m. or after 6:00 p.m. on any day; or longer than an 8-hour period on any day. The Contractor shall apply in writing to the Engineer for such permission, no later than noon on the working day prior to the day for which the Contractor is requesting permission to work.

Permission to work between the hours of 10:00 p.m. and 7:00 a.m. during weekdays and between the hours of 10:00 p.m. and 9:00 a.m. on weekends or holidays may also be subject to noise control requirements. Approval to continue work during these hours may be revoked at any time the Contractor exceeds the Contracting Agency's noise control regulations or complaints are received from the public or adjoining property owners regarding the noise from the Contractor's operations. The Contractor shall have no claim for damages or delays should such permission be revoked for these reasons.

Permission to work Saturdays, Sundays, holidays, or other than the agreed upon normal straight time working hours Monday through Friday may be given subject to certain other conditions set forth by the Contracting Agency or Engineer. These conditions may include but are not limited to:

- 1 • The Engineer may require designated representatives to be present during the
- 2 work. Representatives who may be deemed necessary by the Engineer include,
- 3 but are not limited to: survey crews; personnel from the Contracting Agency’s
- 4 material testing lab; inspectors; and other Contracting Agency employees when
- 5 in the opinion of the Engineer, such work necessitates their presence.
- 6 • Considering the work performed on Saturdays, Sundays, and holidays as working
- 7 days with regard to the contract time.
- 8 • Considering multiple work shifts as multiple working days with respect to
- 9 contract time, even though the multiple shifts occur in a single 24-hour period.

10 **1-08.3 Progress Schedule**

11 **1-08.3(2)A Type A Progress Schedule**

12 *(March 13, 2012 APWA GSP)*

13 Revise this section to read:

14

15 The Contractor shall submit three (3) copies of a Type A Progress Schedule no later

16 than at the preconstruction conference, or some other mutually agreed upon

17 submittal time. The schedule may be a critical path method (CPM) schedule, bar

18 chart, or other standard schedule format. Regardless of which format used, the

19 schedule shall identify the critical path. The Engineer will evaluate the Type A

20 Progress Schedule and approve or return the schedule for corrections within 15

21 calendar days of receiving the submittal.

22 **1-08.5 Time for Completion**

23 *(*****)*

24 Section 1-08.5 is supplement with the following:

25

26 Time of completion for this project shall be 90 working days from the Notice to

27 Proceed Date.

28 **1-10 TEMPORARY TRAFFIC CONTROL**

29 **1-10.2 Traffic Control Management**

30 **1-10.2(1) General**

31 *(December 1, 2008 WSDOT GSP)*

32 Section 1-10.2(1) is supplemented with the following:

33

1 Only training with WSDOT TCS card and WSDOT training curriculum is recognized in
2 the State of Washington. The Traffic Control Supervisor shall be certified by one of the
3 following:

4 **The Northwest Laborers-Employers Training Trust**

5 27055 Ohio Ave.
6 Kingston, WA 98346
7 (360) 297-3035

8 **Evergreen Safety Council**

9 401 Pontius Ave. N.
10 Seattle, WA 98109
11 1-800-521-0778 or (206) 382-4090

12 **The American Traffic Safety Services Association**

13 15 Riverside Parkway, Suite 100
14 Fredericksburg, Virginia 22406-1022
15 Training Dept. Toll Free (877) 642-4637
16 Phone: (540) 368-1701

17 **1-10.2(2) Traffic Control Plans**

18 (*****)

19 The first sentence of Section 1-10.2(2) is replaced with the following:

20
21 No approved Traffic Control Plan is provided by the Contracting Agency in the Contract
22 Plans. The Contractor shall submit site-specific Traffic Control for all phases of the
23 project to the Engineer for approval:

- 24
25 1. A minimum of twenty (20) working days in advance of when the Traffic Control
26 will be implemented for work within WSDOT Limited Access (SR 531 and 27th
27 Ave NE traffic signal modification and 27th Ave NE widening).
28 2. A minimum of five working days in advance of when the Traffic Control will be
29 implemented for work outside WSDOT Limited Access.
30

31 The Traffic Control Plans shall be shown on a plan depicting the project site. The
32 Manual on Uniform Traffic Control Devices (MUTCD, Part 6) shall be used as a
33 guide. Informational WSDOT Traffic Control Plans are included in Appendix D of the
34 Project Manual.
35

36 The second paragraph of Section 1-10.2(2) is deleted in its entirety and replaced with the
37 following:

38
39 The Contractor shall not implement any lane, ramp, roadway or sidewalk closures
40 without a site specific Traffic Control Plan approved by the Engineer.

1 **1-10.2(4) Construction Phasing Plan**

(New Section)

2 (*****)

3 This project requires the contractor to completely re-build a three-leg intersection and
4 maintain traffic on a drivable surface throughout the duration of the project.
5 Construction phasing and traffic control are completely interlinked and interdependent
6 for this project. Therefore, a comprehensive construction-phasing plan that is linked to a
7 comprehensive traffic control plan is required. The intent of the phasing plan is for the
8 Contractor to show how the major elements of work and traffic routing will be
9 accomplished to meet the required goals and parameters established by the City. The
10 intent of the traffic control plan per Section 1-10.2(2) is to show specifically how the
11 phasing plan traffic routing will be handled.

12
13 The construction phasing plans appearing in the Contract Plans show a method of
14 phasing the major construction. All construction alignments, striping, paving, and other
15 traffic control devices shown are schematic only.

16
17 The Contractor shall prepare, designate, and adopt in writing the specific construction
18 phasing plan(s) required for their method of performing the work by showing the
19 necessary construction alignments, temporary striping, paving, temporary signs, and
20 other traffic control devices required for the project. The Contractor’s construction
21 phasing plan(s) shall be in accordance with the established standards for plan
22 development as shown in the MUTCD, Part VI, as adopted by WSDOT. The
23 Contractor’s letter designating and adopting the specific construction phasing plan(s) or
24 any proposed modified plan(s) for the project shall be submitted to the Engineer for
25 approval at least five calendar days in advance of the time the construction begins.

26
27 The following restrictions will apply:

28
29 **Roadway Closure** – No complete roadway closure is allowed. The intersection
30 must remain open to traffic at all times.

31
32 **Emergency Access** – Emergency vehicles shall be provided access through the
33 intersection construction at all times.

34
35 **Minimum Lane Configuration** – Eleven (11) feet is the minimum lane width.

36
37 **Two-way Traffic** - Two-way traffic must be maintained on SR 531 at all times.

38
39 **Single-lane Closures** - Single-lane closures are permitted only between 8:30 a.m.
40 and 2:30 p.m..

41
42 **Turning Movements** – Existing turning movements on SR 531 must be maintained
43 at all times.

1
2
3
4
5
6
7
8
9

Driving surface – Vehicles will be allowed to drive on subgrade for a maximum of 48 hours during construction in accordance with an approved phasing and traffic control plan. All other times will require a temporary driving surface of a minimum of 1-1/2 inches of asphalt-treated base (ATB). Potholes and ruts greater than 2 inches deep shall be repaired immediately.

The contractor is encouraged to place ATB such that it is at the final ATB grades per the pavement section as shown in the Plans and does not require removal.

This Page Intentionally Left Blank

1
2

**DIVISION 2
EARTHWORK**

3 **2-01 CLEARING, GRUBBING, AND ROADSIDE CLEANUP**

4 **2-01.1 Description**

5 *(March 13, 1995 WSDOT GSP)*

6 Section 2-01.1 is supplemented with the following:

7
8 Clearing and grubbing on this project shall be performed within the following limits:

9
10 The cut and fill limits as shown on the Plans.

11 **2-01.3 Construction Requirements**

12 Section 2-01.3 is supplemented with the following:

13
14 Existing landscaping, including, but not limited to, sod, rockeries, bark mulch or wood
15 chips, decorative gravel or rock, bushes, and shrubbery adjacent to the work area shall be
16 protected from damage. The cost of this work shall be included in the “Clearing and
17 Grubbing” lump sum bid item.

18 **2-01.3(3)A Surface Improvements** **(New Section)**

19 The Contractor shall be responsible for the protection and preservation of existing
20 surface improvements and trees outside the construction limits and any damage resulting
21 from the Contractor’s operations shall be the Contractor’s sole responsibility.

22 **2-01.3(3)B Subsurface Improvements** **(New Section)**

23 The Contractor shall be responsible for locating subsurface improvements and utilities
24 and for coordinating activities with utilities and others.

25 **2-02 REMOVAL OF STRUCTURES AND OBSTRUCTIONS**

26 **2-02.1 Description**

27 Section 2-02.1 is supplemented with the following:

28
29 This work involves the removal of catch basins, storm drainage manholes, storm
30 drainpipes, culverts and full depth pavement at locations shown on the Plans or as
31 directed by the Engineer. The work also includes backfilling trenches, holes, or pits that
32 result from such removal.

1 **2-02.2 Materials**

2 Section 2-02.2 is supplemented with the following:

3

4 Backfill for structure removal shall meet the requirements of Section 9-03.14(1) for
5 gravel borrow.

6 **2-02.3 Construction Requirements**

7 Section 2-02.3 is supplemented with the following:

8

9 The Contractor shall stack the material where directed by the Engineer. The Contractor
10 shall contact the Engineer at least five working days prior to scheduled delivery of the
11 items to confirm delivery arrangements.

12

13 Incidental items shall be removed and disposed of in accordance with the requirements
14 of Section 2-02 of the Standard Specifications.

15

16 The Contractor shall remove and dispose of existing drainage structures or pipes
17 identified for removal in the Plans that lie wholly or partially within the right-of-way.
18 The resulting voids shall be backfilled in accordance with Section 2-03.3(14)C,
19 Method B. The Engineer may direct the Contractor to use native material for backfill if
20 the Engineer determines that material is suitable for such use.

21

22 The salvage of any structures shall be in accordance with Section 2-02.3.

23

24 Add the following new section:

25 **2-02.3(4) Sawcutting (New Section)**

26 Where sawcutting is required, the sawcut shall be 3 inches deep, minimum. Where the
27 existing pavement is more than 3 inches thick, the portion below the top 3 inches may be
28 broken after the sawcut is made. Sawcuts shall be cleaned by the use of high-pressure
29 water (1,400 psi or greater), or another method as approved by the Engineer.

30

31 Care shall be taken to prevent damage to the existing pavement specified to remain. All
32 damage to existing pavement specified to remain shall be repaired in accordance with
33 Section 1-07.13.

34

35 The Contractor shall perform all sawcutting work, including all containment, collection,
36 and disposal of sawcutting debris and wastewater, in accordance with Section 1-07.5(3)
37 as supplemented in these Special Provisions.

38

39 Add the following new section:

1 **2-02.3(5) Sawcut Residue and Slurry** **(New Section)**

2 Construction activities that generate residue from sawcutting shall be subject to the
3 following:

4 **Collection, Containment, and Disposal**

5 Removal of residue and slurry from the immediate roadway shall be done on a
6 continuous basis. Residue and slurry shall not be allowed to drain across traffic lanes
7 and shoulders or drain into any stormwater conveyance system, including catch basins,
8 inlets, or ditches. Any discharge to surface waters, including wetlands, is a violation of
9 State water quality standards.

10 The Contractor shall develop a Collection, Containment, and Disposal Plan identifying
11 how the residue and slurry will be contained and collected. The residue and slurry shall
12 become the property of the Contractor and shall be disposed of by hauling to a
13 Contractor-provided disposal site.

14 The approved Collection, Containment, and Disposal Plan shall be implemented prior to
15 commencing any pavement grinding or sawcutting operation.

16 The Contractor shall submit the following items to the Engineer for review and approval
17 ten calendar days prior to commencing the sawcutting operation:

- 18 1. Collection, Containment, and Disposal Plan identifying all proposed methods to
19 prevent discharges into the existing drainage systems.
20 2. Location of all off-site disposal sites, including copies of all applicable permits and
21 approvals for the use of those sites.

22 Preparation and implementation of the Collection, Containment, and Disposal Plan shall
23 be incidental to the lump sum cost for “Removal of Structures and Obstructions”.

24 **2-03 ROADWAY EXCAVATION AND EMBANKMENT**

25 **2-03.3 Construction Requirements**

26 **2-03.3(14)C Compacting Earth Embankments**

27 Supplement this section with the following:

28 Method B shall be used for this project.

1 **2-05 PAVEMENT PULVERIZING**

(New Section)

2 **2-05.1 Description**

3 This Work consists of pulverizing the existing asphalt concrete as indicated on the
4 Plans. The Work shall include lowering and protecting existing utility lids; and pulverizing
5 in conformance with these specifications and in conformity with the lines, grades, depths,
6 and typical cross sections shown on the Plans or as established by the Engineer.

7 **2-05.3 Construction Requirements**

8 The Work of this Section shall be performed in sequence with other work of this project as
9 indicated in Section 1-05.14, "Cooperation with Other Contractors."

10

11 As shown on the Plans, existing asphalt concrete pavement within the project limits shall be
12 pulverized by a method that does not damage or dislodge the material below the existing
13 asphalt. Full depth pavement shown on the Plans for removal shall be removed and
14 disposed of offsite.

15

16 Existing raised pavement markers shall be removed prior to pulverizing of pavement.

17

18 The pulverized material shall conform to the following gradation:

<u>Sieve Size</u>	<u>Percent Passing (by weight)</u>
2" square opening	100%

19

20 Acceptance of the gradation will be based on visual inspection by the Contracting Agency.

21 Pulverized pavement cannot be used under sidewalks or side slopes outside sidewalks.

22 Pulverized pavement can only be used within the roadway section.

1
2 **DIVISION 5**
SURFACE TREATMENTS AND PAVEMENTS

3 **5-04 HOT MIX ASPHALT**

4 **5-04.3 Construction Requirements**

5 **5-04.3(3)A Material Transfer Device / Vehicle**

6 (*****)

7 The first paragraph of this section is revised to read:

8
9 Additionally, a material transfer device or vehicle (MTD/V) is not required.

10 **5-04.3(7)A2 Statistical or Nonstatistical Evaluation**

11 *(January 16, 2014 APWA GSP)*

12 Delete this section and replace it with the following:

13
14 Mix designs for HMA accepted by Nonstatistical or Commercial evaluation shall;

- 15
16
- 17 • Be submitted to the Engineer on WSDOT Form 350-042
 - 18 • Have the aggregate structure and asphalt binder content determined in
19 accordance with WSDOT Standard Operating Procedure 732 and meet the
20 requirements of Sections 9-03.8(2) and 9-03.8(6).
 - 21 • Have anti-strip requirements, if any, for the proposed mix design determined in
22 accordance with WSDOT Test Method T 718 or based on historic anti-strip and
23 aggregate source compatibility from WSDOT lab testing. Anti-strip evaluation
24 of HMA mix designs utilized that include RAP will be completed without the
25 inclusion of the RAP.

26 At or prior to the preconstruction meeting, the contractor shall provide one of the
27 following mix design verification certifications for Contracting Agency review:

- 28
- 29 • The proposed mix design indicated on a WSDOT mix design/anti-strip report that is
30 within one year of the approval date
 - 31 • The proposed HMA mix design submittal (Form 350-042) with the seal and
32 certification (stamp & signature) of a valid licensed Washington State Professional
33 Engineer.
 - 34 • The proposed mix design by a qualified City or County laboratory mix design report
35 that is within one year of the approval date.

36
37 The mix design will be performed by a lab accredited by a national authority such as
38 Laboratory Accreditation Bureau, L-A-B for Construction Materials Testing, The
39 Construction Materials Engineering Council (CMEC's) ISO 17025 or AASHTO

1 Accreditation Program (AAP) and shall supply evidence of participation in the
2 AASHTO Material Reference Laboratory (AMRL) program.

3
4 At the discretion of the Engineer, agencies may accept mix designs verified beyond the
5 one-year verification period with a certification from the Contractor that the materials
6 and sources are the same as those shown on the original mix design.

7 **5-04.3(8)A1 General**

8 *(January 16, 2014 APWA GSP)*

9 Delete this section and replace it with the following:

10
11 Acceptance of HMA shall be as defined under nonstatistical or commercial
12 evaluation.

13
14 Nonstatistical evaluation will be used for all HMA not designated as Commercial
15 HMA in the contract documents.

16
17 The mix design will be the initial JMF for the class of HMA. The Contractor may
18 request a change in the JMF. Any adjustments to the JMF will require the approval
19 of the Engineer and must be made in accordance with Section 9-03.8(7).

20
21 Commercial evaluation may be used for Commercial HMA and for other classes of
22 HMA in the following applications: sidewalks, road approaches, ditches, slopes,
23 paths, trails, gores, prelevel, and pavement repair. Other nonstructural applications
24 of HMA accepted by commercial evaluation shall be as approved by the Engineer.
25 Sampling and testing of HMA accepted by commercial evaluation will be at the
26 option of the Engineer. Commercial HMA can be accepted by a contractor
27 certificate of compliance letter stating the material meets the HMA requirements
28 defined in the contract.

29 **5-04.3(8)A4 Definition of Sampling Lot and Sublot**

30 *(January 16, 2014 APWA GSP)*

31 Section 5-04.3(8)A4 is supplemented with the following:

32
33 For HMA in a structural application, sampling and testing for total project quantities
34 less than 400 tons is at the discretion of the engineer. For HMA used in a structural
35 application and with a total project quantity less than 800 tons but more than 400
36 tons, a minimum of one acceptance test shall be performed:

- 37
38 i. If test results are found to be within specification requirements, additional
39 testing will be at the Engineer's discretion.
40 ii. If test results are found not to be within specification requirements, additional
41 testing as needed to determine a CPF shall be performed.

1 **5-04.3(8)A5 Test Results**

2 (January 16, 2014 APWA GSP)

3 The first paragraph of this section is deleted.

4 **5-04.3(8)A6 Test Methods**

5 *(January 16, 2014 APWA GSP)*

6 Delete this section and replace it with the following:

7
8 Testing of HMA for compliance of Va will be at the option of the Contracting
9 Agency. If tested, compliance of Va will be use WSDOT Standard Operating
10 Procedure SOP 731. Testing for compliance of asphalt binder content will be by
11 WSDOT FOP for AASHTO T 308. Testing for compliance of gradation will be by
12 WAQTC FOP for AASHTO T 27/T 11.

13 **5-05 Cement Concrete Pavement**

14 **5-05.1 Description**

15 Section 5-05.1 is supplemented with the following:

16 *(August 6, 2012)*

17 This Work consists of furnishing and placing for pigmented, textured, or textured and
18 pigmented cement concrete pavement for truck aprons and hardscape areas at the
19 locations and depth as shown in the Plans.

20 **5-05.2 Materials**

21 Section 5-05.2 is supplemented with the following:

22 *(August 6, 2012)*

23 Pigment color for cement concrete pavement for truck apron shall be one chosen from
24 the manufactures and colors listed below:

Manufacturer	Pigment Color
BASF	“Red River Clay,” RC5006
Bominite	“Brick Red”
Dvais Colors	“Brick Red,” 160
Increte Systems	“Brick Red”
Solomon Colors	“Brick,” 417

26

1 Pigment color for cement concrete pavement for hardscape areas shall be one chosen
2 from the manufactures and colors listed below:

Manufacturer	Pigment Color
Davis Colors	“Dark Gray (iron oxide) 860”
Increte Systems	“Dark Gray”

4
5 The pigment shall be incorporated in accordance with the manufacturer’s
6 recommendations.

7 **5-05.3 Construction Requirements**

8 Section 5-05.3 is supplemented with the following:

9
10 (*****)

11
12 Work shall be performed by workers experienced with concrete stamping and concrete
13 coloring.

14
15 For textured cement concrete pavement, the Contractor shall provide a job-site sample to
16 be approved by the Engineer prior to placing textured cement concrete. The sample
17 shall be a minimum of 6 feet by 6 feet, completed panel, including stamp pattern,
18 integral color, color hardener, powder release agent, and sealer. The job site sample shall
19 be 4-inch depth concrete. The approved sample shall be the standard for the balance of
20 the Work installed and shall be protected against damage until final approval from the
21 Engineer.

22
23 Transverse construction joints and transverse contraction joints shall be placed
24 perpendicular or radial to the back of curb. Joint spacing shall be a maximum of 15 feet
25 apart and equally spaced along the length of the textured cement concrete. Joints and
26 reinforcing shall be constructed as shown in the WSDOT Standard Plan A-40.10-02 of
27 these special provisions.

28 *(August 6, 2012)*

29 **Pigmented Cement Concrete**

30 Curing shall be in accordance with Section 5-05.3(13) and be applied to the surface in
31 accordance with the manufacturer's recommendations. If liquid membrane-forming
32 concrete curing compound is used it shall meet the requirements of ASTM C 309
33 Type 1-D.

34
35 The Contractor shall provide a 2 foot by 2 foot sample panel, that has been cured a
36 minimum seven days, showing the color of cement concrete to the Engineer for
37 acceptance before placing any pigmented cement concrete pavement.

1 (August 6, 2012)

2 **Textured Cement Concrete**

3 Textured cement concrete pavement pattern for truck aprons shall be one chosen from
4 the manufactures and patterns listed below:
5

Manufacturer	Pattern
Bomanite	“Running Bond Cobblestone”
Brickform	“Pennsylvania Cobble-Sanded Joint,” TM820
Increte Systems, Inc.	“Euro Cobble Running Bond,” SECR S001
Matcrete	“Large Cobblestone,” P-16
Renew-Crete Systems	“London Cobblestone”
Scofield	“Old Belgium Stone: Running Bond” (4530)

6
7 Textured cement concrete pavement pattern for hardscape areas shall be one chosen from
8 the manufactures and patterns listed below:
9

Manufacturer	Pattern
Bomanite	River Rock
Increte Systems,	Savanah Stone
Matcrete	Large River Rock

10
11 A mat or stamp shall be used to imprint the pattern into the concrete surface.
12 Curing shall be in accordance with Section 5-05.3(13) and be applied to the surface in
13 accordance with the manufacturer's recommendations. If liquid membrane-forming
14 concrete curing compound is used it shall meet the requirements of ASTM C309
15 Type 1-D.

16 **5-05.3(1) Concrete Mix Design for Paving**

17 (April 3, 2006)

18 **Submittals**

19 Prior to beginning any concrete work, the Contractor shall submit a plan, for the
20 Engineer’s review and approval, outlining the procedures to be used to prevent high pH
21 stormwater or dewatering water from entering surface waters. The plan shall include
22 how the pH of the water will be maintained between pH 6.5 and pH 8.5 prior to being
23 discharged from the project or entering surface waters. The plan shall conform to the
24 requirements of Section 8-01.

25 (August 6, 2012)

26 **Aggregate for Textured Cement Concrete Pavement**

27 Coarse aggregate for Textured Cement Concrete Pavement shall conform to
28 Section 9-03.1(4), AASHTO grading No. 7. An alternate for combined gradation for
29 Textured Cement Concrete Pavement conforming to Section 9-03.1(5) may be proposed,
30 that has a nominal maximum aggregate size of 1/2 inch sieve.

This Page Intentionally Left Blank

1 **DIVISION 7**
2 **DRAINAGE STRUCTURES, STORM SEWERS, SANITARY SEWERS, WATER**
3 **MAINS AND CONDUITS**

4 **7-04 STORM SEWERS**

5 **7-04.2 Materials**

6 Section 7-04.2 is supplemented with the following:

7
8 One of the following materials shall be used for Storm Drain (SD) Pipe unless otherwise
9 indicated on the Plans and approved by the Engineer:

10
11

Corrugated Polyethylene Storm Sewer Pipe	9-05.20
Polypropylene Storm Sewer Pipe	9-05.24
Ductile Iron Sewer Pipe	9-05.13

12
13

14 **7-12 VALVES FOR WATER MAINS 7-12.3 Construction Requirements**

15 **7-12.3(2) Adjust Valve and Meter Boxes to Grade (New Section)**

16 Where shown on the Plans, water meter boxes, water meter vaults, blow off valves,
17 existing valve boxes, and covers shall be adjusted to grade as staked or otherwise
18 designated by the Engineer. Adjustments to valves shall also include adjustments to
19 operating nuts as directed by the Engineer. Adjustments to grade shall be performed
20 according to Section 7-05.3(1) Adjusting Manholes, Catch Basins, and Other Structures
21 to Grade.

22
23 Relocation operations shall be conducted preventing damage to boxes. Parts or materials
24 damaged due to Contractor's operations shall be replaced at his expense.

25
26 Contractor shall conduct his box adjustments so fully adjusted box allows respective
27 valve or meter to be fully operational. Contractor shall remove debris from adjusted
28 boxes to ensure such operational condition.

29 **7-17 SANITARY SEWERS**

30 **7-17.3 Construction Requirements**

31 **7-17.3(3) Adjust Sanitary Sewer Manhole to Grade (New Section)**

32 Where shown in Plans, sanitary sewer manholes, covers, and cleanouts shall be adjusted
33 to grade as staked or otherwise designated by Engineer. Adjustments to grade shall be
34 performed according to Section 7-05.3(1) Adjusting Manholes, Catch Basins, and Other
35 Structures to Grade.

1
2 Removal operations shall be conducted preventing damage to manholes. Parts or
3 materials damaged due to Contractor's operations shall be replaced at his expense.

1
2

**DIVISION 8
MISCELLANEOUS CONSTRUCTION**

3 **8-01 EROSION CONTROL AND WATER POLLUTION CONTROL**

4 **8-01.3 Construction Requirements**

5 **8-01.3(1) General**

6 Section 8-01.3(1) is supplemented with the following:

7 **Off-Site Stormwater**

8 Stormwater is known to enter the project site at the following locations:

- 9
10 1. Through a combination of enclosed systems and open ditches along SR 531

11
12 The Contractor shall, prior to disruption of the normal water course, intercept the off-site
13 stormwater and pipe it either through or around the project site in such a manner that it is
14 not combined with on-site stormwater and is discharged at its pre-construction outfall
15 point in such a manner that there is no increase in erosion below the site.

16
17 The method for performing this work shall be included in the Contractor's amended
18 Temporary Erosion and Sedimentation Control Plan.

19 **8-01.3(1)A Submittals**

20 Section 8-01.3(1)A is supplemented with the following:

21
22 The Contractor shall submit the Spill Prevention Control and Countermeasures
23 (SPCC) Plan, the amended TESC Plan, and the Stormwater Pollution Prevention
24 Plan (SWPPP) for Construction Activities and Monitoring Plan at the pre-
25 construction conference.

26 **8-01.3(1)B Erosion and Sedimentation Control (ESC) Lead**

27 Section 8-01.3(1)B is supplemented with the following:

28
29 The ESC Lead shall be responsible for implementing the Stormwater Pollution
30 Prevention Plan for Construction Activities and Monitoring Plan (SWPPP), the
31 approved Temporary Erosion and Sedimentation Control Plan (TESC), and Spill
32 Prevention Control and Countermeasures (SPCC) plan.

33 **8-01.3(1) F Stormwater Pollution Prevention Plan for Construction Activities**
34 **and Monitoring Plan (SWPPP) (New Section)**

35 The Contractor's ESC Lead shall update the SWPPP for Construction Activities and
36 Monitoring Plan continually as necessary throughout the life of the project. The SWPPP

1 must be available on site for review by the Department of Ecology. The Contractor shall
2 submit a copy of the SWPPP to the engineer at the pre-construction conference.

3 **8-01.3(2) Seeding, Fertilizing, and Mulching**

4 **8-01.3(2)A Preparation for Application**

5 Section 8-01.3(2)A is supplemented with the following:

6
7 No cultivation shall occur in areas within the drip line of existing vegetation
8 scheduled to remain.

9
10 All areas that are to be seeded or landscaped shall be cleared of undesirable and
11 unwanted vegetation, which may or may not be present on the project site, including
12 Reed Canary Grass, Purple Loosestrife, Himalayan and Evergreen Blackberry,
13 Scotch Broom, Morning Glory, Thistle, Butterfly Bush, Phragmites, and Japanese
14 Knotweed. The site may also include other invasive and competitive vegetation, as
15 determined by the Engineer, which needs to be controlled.

16
17 Topsoil type A shall not be placed, when in the opinion of the Engineer, a condition
18 detrimental to successful application and incorporation exists.

19
20 The Contractor shall place topsoil type A to a reasonable even grade in accordance
21 with grading Plans as shown in the Plans and without localized low areas to trap
22 water.

23 **8-01.3(2)B Seeding and Fertilizing**

24 Section 8-01.3(2)B is supplemented with the following:

25 *(January 3, 2006)*

26 Grass seed shall be a commercially prepared mix, made up of low growing species
27 which will grow without irrigation at the project location, and approved by the
28 Engineer. The application rate shall be two pounds per 1000 square feet.

29 *(January 3, 2006)*

30 Fertilizer shall be a commercially prepared mix of 10-20-20 and shall be applied at
31 the rate of 10 pounds per 1000 square feet.

32
33 Samples shall be supplied to the Engineer for approval at least 10 days prior to
34 application. Approval is required before usage.

35 **8-01.3(2)C Liming**

36 Section 8-01.3(2)C is supplemented with the following:

37
38 Lime shall be applied at the rate of 1,000 pounds per acre.
39

1 **8-01.3(8) Street Cleaning**

2 Section 8-01.3(8) is supplemented with the following:

3
4 The Contractor shall be responsible for controlling dust and mud within the project
5 limits and on any street that is utilized by his equipment for the duration of the
6 project. The Contractor shall be prepared to use power sweepers and any other
7 pieces of equipment necessary to avoid creating a nuisance or safety hazard. All
8 streets used by the Contractor under this Contract shall be maintained in a clean
9 condition.

10
11 Contractors, operating dump trucks and other equipment on paved streets and
12 roadways outside the area of construction, shall clean these streets at the conclusion
13 of each day’s operation and, if required by the Contracting Agency, during the day.
14 Streets within the area of construction will require cleaning on a daily basis.

15
16 Any violation of these requirements will result in a citation for littering the traveled
17 way and will be sufficient grounds for the Contracting Agency to order the roadways,
18 streets, and appurtenances cleaned by others and to deduct all costs of such cleaning
19 from any monies due or to become due to the Contractor.

20
21 Complaints of dust, mud, or unsafe practices and/or property damage to Contracting
22 Agency will be transmitted to the Contractor and prompt action in correcting will be
23 required. Written notice of correction of complaint items will be required should
24 repetitive complaints be received by the Contracting Agency. Should the Contractor
25 fail to perform, the Contracting Agency shall, at the Contractor’s expense, hire the
26 necessary work done.

27
28 Upon completion of the work, the Contractor shall remove all rubbish, scrap
29 material, tools, surplus materials, and equipment used in and about the work.

30
31 Before the Contract shall be considered complete and prior to final payment, the
32 Contractor shall remove all surplus materials, temporary structures, including
33 foundations, thereof, debris of every nature, resulting from his operations, shall clean
34 out all ditches that may have been filled during the work, replace damaged surfacing,
35 and put the site in a neat, orderly condition.

36 **8-02 ROADSIDE RESTORATION**

37 **8-02.1 Description**

38 Section 8-02.1 is replaced with following:

39
40 This work consists of furnishing and placing topsoil, compost, mulch, soil amendments,
41 quarry spalls, landscape boulders, and weed barrier fabric and furnishing and planting
42 container plants, balled and burlapped plants, seeding, controlling weeds, performing

1 plant establishment activities, and soil bioengineering in accordance with these
2 Specifications and as shown in the Plans or as designated by the Engineer.
3 Trees, shrubs, ground covers, and seeds will hereinafter be referred to collectively as
4 “plants” or “plant material”.

5
6 Plant material quantity, size and condition, and spacing shall be as indicated in the Plans
7 or these Special Provisions.

8
9 All landscape work shall be performed by a licensed Landscaping Contractor registered
10 in the State of Washington. Landscaping shall be performed as shown on the Plans, in
11 accordance with the 2014 Standard Specifications, the latest edition of the American
12 Nursery and Landscape Association (the A.N.L.A. Standard) and these Special
13 Provisions.

14
15 The Contractor must be experienced in landscape work of the highest quality and have
16 facilities and personnel adequate for the work specified. The Contractor shall be
17 acquainted with all other work related to site improvements and other work which might
18 affect preparation for or installation of planting. The Contractor must be familiar with
19 the A.N.L.A. Standard.

20
21 Layout is diagrammatic and may require field adjustment according to the direction of
22 the Engineer. Any discrepancies in the Plans shall be brought to the immediate attention
23 of the Engineer before work proceeds further.

24
25 Definition: The word “provide” means “furnish and install” for this Work.

26 27 **8-02.2 Materials**

28 Section 8-02.2 is supplemented with the following:

29 **Tree Root Barriers**

30 Tree root barriers shall be an injection molded or extruded modular component made
31 of high-density polypropylene or polyethylene plastic with a minimum of 30%
32 recycled materials. Panels shall have a minimum thickness of 0.080” (2 mm). Each
33 panel shall have molded vertical ribs (four minimum) and locking strips, integral
34 male/female sliding locks, intergraded zipper joining system. Vertical root-deflecting
35 ribs or channels shall be between 1/2 inch (12.7 mm) and 0.008” (0.2 mm) high,
36 perpendicular to the panel, and between 5.91 inches (150 mm) and 7.87 inches
37 (200 mm) apart. Panels shall be a minimum of 24-inches wide by 36-inches deep, or
38 as shown on the Plans. The Contractor shall submit for approval a catalogue cut for
39 the material and installation.

40 **8-02.3 Construction Requirements**

41 **8-02.3(4)A Topsoil Type “A”**

42 Section 8-02.3(4) A is supplemented with the following:

1
2 Topsoil Type A shall be Cedar Grove 3-Way Topsoil. Provide a 1-gallon sample,
3 fertility analysis, and sieve analysis from an approved topsoil laboratory to Engineer
4 for approval prior to delivery.

5 **8-02.3(5) Planting Area Preparation**

6 Section 8-02.3(5) is supplemented with the following:

7
8 After the initial planting area weed control, soil placement, and grading are
9 completed, and prior to the installation of planting, all designated planting areas shall
10 be amended with Topsoil Type A.

11
12 Subgrades: Contractor shall establish subgrades at a depth sufficient for the
13 specified depth of topsoil, mulch, and quarry spalls. Establish subgrades during dry
14 soil conditions immediately prior to topsoil placement to avoid construction activity
15 compaction. Remove and dispose of vegetation, crushed rock, excess asphalt,
16 surface irrigation components not to remain, excess material, construction waste
17 debris, and rock as required to create subgrades. Eradicate any surface vegetation
18 rooted in the subgrade. Thoroughly scarify and rip all compacted subgrades in
19 landscape planting beds and street tree planting areas to a depth of 6 inches during
20 dry conditions prior to topsoil placement. Remove all surface rocks, vegetation, and
21 debris larger than 3 inches.

22
23 The Contractor shall rake planting areas free of all rock, roots, vegetation, and debris
24 larger than 1 inch and remove and dispose off site prior to planting.

25 **8-02.3(7) Layout of Planting**

26 Section 8-02.3(7) is replaced with the following:

27
28 The Contractor shall stake the locations of plants for approval by the Engineer prior
29 to any installation activities. The Engineer may direct the Contractor to relocate any
30 plant material installed without the prior location approval of the Engineer. The
31 Plans are diagrammatic. Promptly notify the Engineer of any conflicts between
32 Drawing locations of plant materials and field conditions. The placement of trees
33 shall comply with the City of Marysville’s code requirements for minimum setbacks
34 from underground utilities, fire hydrants, and light poles. Trees shall be located so
35 that their trunk is a minimum of one-third of the spray radius away from the nearest
36 sprinkler head.

37 **8-02.3 (10)Fertilizers**

38 Section 8-02.3(10) is supplemented with the following:

39
40 Fertilizer: The Contractor shall provide slow release granular or pelleted fertilizer
41 consisting of 50 percent water-insoluble nitrogen, phosphorous, and potassium in the
42 following composition by weight:
43

1
2
3
4
5
6
7
8
9
10
11
12
13
14
15
16
17
18
19
20
21
22
23
24
25
26
27
28
29
30
31
32
33
34
35
36
37
38
39
40
41
42
43

20 percent nitrogen
10 percent phosphorous
10 percent potassium

Fertilizer shall be less than 0.5 percent inert contaminants and free of toxic substances.

Fertilizer Tablets: The Contractor shall provide slow release commercial grade 21 gram fertilizer in tablet form in the following composition by weight plus micronutrients:

20 percent nitrogen
10 percent phosphorous
5 percent potassium

Fertilizer shall be less than 0.5 percent inert contaminants and free of toxic substances.

The Contractor shall provide and apply fertilizer at the time of initial planting. The contractor shall retain empty fertilizer containers for review by the Engineer.

Landscape Area: The Contractor shall apply fertilizer according to the manufacturer’s instructions throughout area to be planted.

Fertilizer Tablets: The Contractor shall evenly distribute within the planting pits 6 fertilizer tablets per tree and 2 fertilizer tablets per shrub.

8-02.3 (13) Plant Establishment

Section 8-02.3(13) is supplemented with the following:

The plant establishment plan shall show the scheduling, frequency, dates, materials, and equipment utilized, whichever may apply, for all plant establishment activities including, but not limited to, the following:

A. Plant Establishment Activities:

1. Weed Control: Remove weeds and invasive plant materials not installed with this Work bi-weekly from April 1 to October 1 and monthly during other months.
2. Fertilizing: Apply fertilizer to the landscape area, excluding the bio-retention cells, according to manufacturer’s instructions once annually in April.
3. Litter and Debris Removal: Remove litter from the site monthly and remove any litter or landscape debris from hardscape surfaces with each visit. Rake and remove leaves once annually in November.

- 1 4. Pruning: Once annually prune as required to remove damaged plant
- 2 materials throughout the year. For trees, prune only as necessary to remove
- 3 damaged limbs.
- 4 5. Insect and Disease Control.
- 5 6. Erosion Control Methods and Procedures: Promptly notify Engineer of any
- 6 visible signs of erosion or settlement and corrective action being taken.
- 7 7. Plant care: Adjust tree staking as required. Immediately remove and replace
- 8 broken tree stakes. Adjust plant material that has settled or is leaning.
- 9 Remove and replace diseased, dying, dead, or missing plant materials during
- 10 the plant establishment period. Remove and replace any trees with a
- 11 damaged or missing central leader. The Work does not include vehicular
- 12 damage caused by others than the Contractor.

13

14 B. Other items as determined by the Contractor.

15

16 C. Supervisor/Responsible Contact Name.

- 17
- 18 1. Local address.
- 19 2. Local telephone number.

20

21 D. Sign and date the Plant Establishment Plan.

22

23 Failure to comply with the plant establishment plan or to revise the plan as outlined by

24 the Engineer will increase the duration of the plant establishment period.

25

26 Failure to comply with corrective steps as outlined by the Engineer will result in a

27 suspension of time for the plant establishment period.

28

29 Any such suspension of time will not be lifted until all unsatisfactory conditions have

30 been corrected to the satisfaction of the Engineer. Any suspensions for noncompliance

31 will increase the duration of the plant establishment period.

32 **8-04 CURB, GUTTERS, AND SPILLWAYS**

33 **8-04.3 Construction Requirements**

34 **8-04.3(1) Cement Concrete Curbs, Gutters, and Spillways**

35 Section 8-04.3(1) is supplemented with the following:

36

37 Truck Apron Cement Concrete Curb shall be constructed with air entrained concrete

38 Class 4000 conforming to the requirements of Section 6-02. All other requirements

39 for Cement Concrete Curb shall apply to Truck Apron Cement Concrete Curb.

40

41 Concrete placement shall be accomplished with line and grade control such that a

42 10-foot-long straight edge placed on the concrete surface in the gutter or against the

1 face of the curb shows no variance greater than 1/8 inch in grade or 1/4 inch on line,
2 except at a designed angle point. Under no circumstances shall variances be allowed
3 that cause drainage away from the catch basin or other drainage structures.
4

5 The first sentence in the fourth paragraph of Section 8-04.3(1) is revised to read:
6

7 Expansion joints in the curb or curb and gutter shall be spaced at 15-foot intervals, at
8 the beginning and end of curb returns, drainage structures, bridges, and cold joints
9 with existing curbs and gutters.

10 **8-06 CEMENT CONCRETE DRIVEWAY ENTRANCES**

11 **8-06.1 Description**

12 Section 8-06.1 is supplemented with the following:
13

14 This Work shall consist of constructing Cement Concrete Driveway as shown in the
15 Plans and in accordance with these Specifications.

16 **8-06.3 Construction Requirements**

17 Delete this Section and replace it with the following:
18

19 The concrete mix for all work shall be air-entrained concrete Class 4000 according to
20 Section 6-02 Concrete Structures, with a maximum slump of 3-1/2 inches. The
21 Contractor shall use a three-day mix to minimize the down time for access.
22

23 The Contractor shall maintain access to all properties at all times by use of crushed
24 surfacing top course or as directed by the Engineer. All costs associated with
25 maintaining access during construction shall be considered incidental to and included in
26 the various bid items involved.
27

28 Contractor shall place and maintain crushed surfacing material adjacent to all existing
29 driveway and sidewalk edges to provide a temporary gradual surface transition until
30 final pavement is placed.
31

32 Contractor shall notify property owners, in writing, with additional copy given to City's
33 Project Manager, a minimum of 48 hours in advance of removal of each property
34 owners' driveway.
35

36 Driveways shall be placed in two sections to maintain access, unless otherwise approved
37 by the property owner and the Engineer.
38

39 Driveway surface finish shall comply with Section 8-14.3 of the Standard Specifications.

1 **8-14 CEMENT CONCRETE SIDEWALKS**

2 **8-14.3 Construction Requirements**

3 Section 8-14.3 is supplemented with the following:

4

5 Cement concrete bike ramp and sidewalk ramp, shall be constructed per details shown in
6 the Plans.

7

8 Any sidewalk damaged, defaced, cracked, chipped, or determined to be of poor
9 workmanship, in the opinion of the Contracting Agency, shall be removed, wastehailed,
10 and replaced by the Contractor at the Contractor's expense. Damaged sidewalk shall be
11 removed at a construction or expansion joint; sawcutting will not be allowed. Sacking,
12 grinding, or spot repaired shall not be considered an acceptable means for repairing
13 unacceptable sections. The Contractor shall further provide verbal and written notice
14 (door hanger) to property owners abutting the Project identifying restricted use of these
15 facilities, etc. This notice must be provided 1 week prior and again 1 day prior to the
16 work being performed.

17 **8-20A ILLUMINATION, TRAFFIC SIGNAL SYSTEMS, AND ELECTRICAL -**
18 **SIGNAL MODIFICATION ONLY**

19 **8-20A.1 Description**

20 These special provisions pertain to the proposed traffic signal modification at the SR 531/27th
21 Ave. NE intersection. The traffic signal modification is a result of adding an additional
22 southbound lane. Modification will include replacement of vehicle detection loops, pedestrian
23 signal indication relocation, traffic signal display modification, installation of new traffic signs,
24 new conduit installation, and electrical conductor replacement as necessary.

25 **8-20A.2 Materials**

26 Section 8-20.2 is supplemented with the following:

27 **Conduit, Innerduct, and Outerduct**

28 Section 9-29.1 is supplemented with the following:

29 *(NWR August 10, 2009)*

30 **Conduit Sealing**

31 Mechanical plugs for cabinet conduit sealing shall be one of the following:

32

- 33 1. Tyco Electronics - TDUX
- 34 2. Jackmoon – Triplex Duct Plugs
- 35 3. O-Z Gedney – Conduit Sealing Bushings

1 The mechanical plug shall withstand a minimum of 5 psi of pressure.

2 **Rigid Metal Conduit Fittings and Appurtenances**

3 Section 9-29.1(2) is supplemented with the following:

4 *(August 10, 2009)*

5 **Conduit Coatings**

6 Electroplated couplings are not allowed.

7 *(NWR March 4, 2009)*

8 **Surface Mounting Conduit Attachment Components**

9 Channel supports and all fastening hardware components shall be Type 304
10 stainless steel. Conduit clamps shall be one piece, two bolt units with lock
11 washers.

12 **Junction Boxes, Cable Vaults, and Pull Boxes**

13 **Standard Duty Junction Boxes**

14 Section 9-29.2(1)A is supplemented with the following:

15 *(January 7, 2013)*

16 **Concrete Junction Boxes**

17 Both the slip-resistant lid and slip-resistant frame shall be treated with Mebac#1
18 as manufactured by IKG industries, or SlipNOT Grade 3-coarse as manufactured
19 by W.S. Molnar Co. Where the exposed portion of the frame is ½ inch wide or
20 less the slip-resistant treatment may be omitted on that portion of the frame. The
21 slip-resistant lid shall be identified with permanent marking on the underside
22 indicating the type of surface treatment (“M1” for Mebac#1; or “S3” for
23 SlipNOT Grade 3-coarse) and the year manufactured. The permanent marking
24 shall be 1/8 inch line thickness formed with a stainless steel weld bead.

25 **Standard Duty Cable Vaults and Pull Boxes**

26 Section 9-29.2(2)A is supplemented with the following:

27 *(January 7, 2013)*

28 Both the slip-resistant lid and slip-resistant frame shall be treated with Mebac#1
29 as manufactured by IKG industries, or SlipNOT Grade 3-coarse as manufactured
30 by W.S. Molnar Co. Where the exposed portion of the frame is 1/2 inch wide or
31 less the slip-resistant treatment may be omitted on that portion of the frame. The
32 slip-resistant lid shall be identified with permanent marking on the underside
33 indicating the type of surface treatment (“M1” for Mebac#1; or “S3” for

1 SlipNOT Grade 3-coarse) and the year manufactured. The permanent marking
2 shall be 1/8 inch line thickness formed with a stainless steel weld bead.

3 **Cover Markings**

4 Section 9-29.2(4) is supplemented with the following:

5 *(NWR February 11, 2013)*

6 **Junction Box Identification**

7 Junction boxes shall be marked “WSDOT” when the junction boxes are to be
8 installed as part of a future raceway system in a bridge structure, vehicle barrier,
9 pedestrian barrier, or roadway crossing and the future raceway system is not
10 connected to an illumination, signal, interconnect, or ITS raceway system.

11
12 Junction boxes, pull boxes and cable vaults containing only Traffic Signal
13 Interconnect (fiber optics) cable shall be marked or embossed with the legend
14 “COMM”.

15 **Electrical Conductors and Cable**

16 Section 9-29.3(2) is supplemented with the following:

17 *(NWR October 5, 2009)*

18 **Video Detection Cable**

19 Coaxial cable or combination (composite/Siamese) cable for video detection shall be
20 RG59/U with a manufacturer’s rating of 600 Volts (Non UL - manufacturer’s voltage
21 rating of the insulation is acceptable). Combination cable shall be in accordance with
22 the video detection system manufacturer’s recommendations for the length of cable
23 required.

24 **Multi-Conductor Cable**

25 Section 9-29.3(2)B is supplemented with the following:

26 *(NWR August 19, 2013)*

27 Two-conductor through ten-conductor unshielded control cable shall be size 14
28 AWG.

1 **Detector Loop Wire**

2 Section 9-29.3(2)F is revised to read as follows:

3 *(NWR October 5, 2009)*

4 Detector loop wire shall use 14 AWG stranded copper conductors, and shall
5 conform to IMSA Specification 51-7, with cross-linked polyethylene (XLPE)
6 insulation encased in a polyethylene outer jacket (PE tube).

7 **Twisted Pair Communications Cable**

8 Section 9-29.3(2)I is supplemented with the following:

9 *(NWR August 10, 2009)*

10 **Aerial Communication Cable**

11 Aerial communication cable shall meet REA specification PE-38 and shall be
12 22 gauge. The number of cable pairs shall be as shown in the Plans.

13 **Light And Signal Standards**

14 Section 9-29.6 is supplemented with the following:

15 *(April 1, 2013)*

16 **Traffic Signal Standards**

17 Traffic signal standards shall be furnished and installed in accordance with the
18 methods and materials noted in the applicable Standard Plans, pre-approved plans, or
19 special design plans.

20
21 All welds shall comply with the latest AASHTO Standard Specifications for
22 Structural Supports for Highway Signs, Luminaires and Traffic Signals. Welding
23 inspection shall comply with Section 6-03.3(25)A Welding Inspection.

24
25 Hardened washers shall be used with all signal arm connecting bolts instead of
26 lockwashers. All signal arm ASTM A 325 connecting bolts tightening shall comply
27 with Section 6-03.3(33).

28
29 Traffic signal standard types and applicable characteristics are as follows:

30
31 Type PPB Pedestrian push button posts shall conform to Standard Plan J-20.10 or
32 to one of the following pre-approved plans:

<u>Fabricator</u>	<u>Drawing No.</u>
Northwest Signal	NWS 3540 Rev. 2 and
Supply Inc.	NWS 3540B Rev. 2
Valmont Ind. Inc.	DB00655 Rev. J
	Sheet's 1, 2 & 3

1
2
3
4
5
6
7
8
9
10
11
12
13
14
15
16
17
18
19
20
21
22
23
24
25
26
27
28
29
30
31
32
33
34
35
36
37

Ameron Pole Prod. Div. WA10TR-1 & WAPPBPBA

Union Metal Corp. TA-10035 Rev. R6 Sht. 1

West Coast Engineering Group WSDOT-PP-01 Rev. 1

KW Industries 10-200-PED-1 Rev. 7, Sheets 1, 2 and 3

Type PS Pedestrian signal standards shall conform to Standard Plan J-20.16 or to one of the following pre-approved plans:

<u>Fabricator</u>	<u>Drawing No.</u>
Northwest Signal Supply Inc.	NWS 3540 Rev. 2 and NWS 3540B Rev. 2

Valmont Ind. Inc. DB00655 Rev.J Sht. 1, 2 & 3

Ameron Pole Prod. Div. WA10TR-1 & WA10TR-2

Union Metal Corp. TA-10025 Rev. R17 Sht. 1 & 2

West Coast Engineering Group WSDOT-PP-02 Rev. 1

American Pole Structures, Inc. WS-PP-03 Rev. 1D

KW Industries 10-200-PED-1 Rev. 7, Sheets 1, 2 and 3

38 Type I Type I vehicle signal standards shall conform to Standard Plan J-21.15 or to one of
39 the following pre-approved plans:

40
41
42
43
44

<u>Fabricator</u>	<u>Drawing No.</u>
Northwest Signal Supply Inc.	NWS 3540 Rev. 2 and NWS 3540B Rev. 2

Valmont Ind. Inc. DB00655 Rev. J

1
2
3
4
5
6
7
8
9
10
11
12
13
14
15
16
17
18
19
20
21
22
23
24
25
26
27
28
29
30
31
32
33
34
35
36
37
38
39
40
41
42
43
44
45
46

Sht. 1 2 & 3

Ameron Pole
Prod. Div

WA10TR-1 & WA10TR-2

Union Metal Corp.

TA-10025 Rev. R17
Sht. 1 & 2

West Coast
Engineering Group

WSDOT-PP-02 Rev. 1

American Pole
Structures, Inc.

WS-PP-03 Rev. 1D

KW Industries

10-200-PED-1
Rev. 7, Sheets 1, 2 and 3

Type FB

Type FB flashing beacon standard shall conform to Standard Plan J-21.16 or the following pre-approved plan:

Fabricator

Drawing No.

Union Metal Corp

50200-B58 Rev. R6
Sht. 1 & 2

Valmont Ind. Inc.

DB00655 Rev.J
Sht. 1 2 & 3

Ameron Pole
Prod. Div.

WA10TR-1 & WA10TR-2

Northwest Signal
Supply, Inc.

NWS 3540 Rev. 2 and
NWS 3540B Rev. 2

KW Industries

10-200-PED-1
Rev. 7, Sheets 1, 2 and 3

Type RM

Type RM ramp meter standard shall conform to Standard Plan J-22.15 or the following pre-approved plan:

Fabricator

Drawing No.

Union Metal Corp

50200-B58 Rev. R6
Sht. 1 & 2

Valmont Ind. Inc.

DB00655 Rev. J
Sht. 1 2 & 3

1
2
3
4
5
6
7
8
9
10
11
12
13
14
15
16
17
18
19
20
21
22
23
24
25
26
27
28
29
30
31
32
33
34
35
36
37
38
39
40
41
42
43
44
45
46

Ameron Pole Prod. Div.	WA10TR-1 & WA10TR-2
Northwest Signal Supply, Inc.	NWS 3540 Rev. 2 and NWS 3540B Rev. 2
KW Industries	10-200-PED-1 Rev. 7, Sheets 1, 2 and 3
<u>Fabricator</u>	
<u>Drawing No.</u>	
Valmont Industries, Inc.	DB 00759 Rev. L
Ameron Pole Product Div.	W6CCTV1 Rev F & W6CCTV2 Rev A
West Coast Engineering Group	AP-WSDOT-CP-01-Rev. 3
American Pole Structures, LLC	WS-CP-01 Rev. 1C Sht. 1 & 2
Union Metal Corporation	Drawing No. P33-B318, R11.1, Sheets 1, 2 of 2
Union Metal Corporation	Drawing No. P33-B323, Rev. 3 Sheets 1, 2 of 2
Northwest Signal Supply, Inc.	Drawing No. NWS 3545 (For Type CCTV) Rev. 1
KW Industries	Drawing No. 10-200-CAM-1 Rev. 6, Sheets 1 and 2

Type CCTV Type CCTV camera pole standards shall conform to one of the following pre-approved Plans:

Type II Characteristics:

Luminaire mounting height	N.A.
Luminaire arms	N.A.
Luminaire arm length	N.A.
Signal arms	One Only

Type II standards shall conform to one of the following pre-approved plans, provided all other requirements noted herein have been satisfied. Maximum (x) (y) (z) signal arm loadings in cubic feet are noted after fabricator.

1
2
3
4
5
6
7
8
9
10
11
12
13
14
15
16
17
18
19
20
21
22
23
24
25
26
27
28
29
30
31
32
33
34
35
36
37
38
39
40
41
42
43
44
45
46

<u>Signal Arm</u>	<u>Length (max)</u>	<u>Fabricator-(x) (y) (z)</u>	<u>Drawing No.</u>
	65 ft.	Valmont Ind. Inc.-(2894)	DB00625-Rev.R, Shts. 1, 2,3 & 4
	65 ft.	Union Metal Corp. (2900)	71026-B86 Rev. R10.1, Shts. 1, 2, & 3 of 3
	65 ft.	Ameron Pole-(2900) Prod. Div.	W3724-1 Rev. J & W3724-2 Rev.G
	65 ft.	Northwest Signal-(2802) Supply Inc.	NWS 3500 Rev. 4 or NWS 3500B Rev. 4
	45 ft.	American Pole(1875) Structures, Inc.	WS-T2-L Rev. 8 Sheet 1 & 2 of 2
	65 ft.	American Pole (2913) Structures, Inc.	WS-T2-H Rev. 8 Sheets 1 & 2 of 2
	65 ft.	KW Industries	10-200-TSP-4 Rev. 5, Sheets 1, 2, and 3
	65 ft	West Coast Engineering Group	WSDOT-TS-01 Rev. 3 Sheets 1, 2, and 3
	65 ft.	Maico Industries (2894)	WSDOTMA Rev. 3 Sheets 1, 2 and 3

Type III	Characteristics:	
	Luminaire mounting height	30 ft., 35 ft., 40 ft., or 50 ft.
	Luminaire arms	One Only
	Luminaire arm type	Type 1
	Luminaire arm length (max.)	16 ft.
	Signal arms	One Only

Type III standards shall conform to one of the following pre-approved plans, provided all other requirements noted herein have been satisfied. Maximum (x) (y) (z) signal arm loadings in cubic feet are noted after fabricator.

1
2
3
4
5
6
7
8
9
10
11
12
13
14
15
16
17
18
19
20
21
22
23
24
25
26
27
28
29
30
31
32
33
34
35
36
37
38
39
40
41
42
43
44
45
46

<u>Signal Arm</u>	<u>Length (max)</u>	<u>Fabricator-(x) (y) (z)</u>	<u>Drawing No.</u>
	65 ft.	Valmont Ind. Inc.-(2947)	DB00625-Rev.R, Shts. 1, 2, 3 & 4 and "J" luminaire arm
	65 ft.	Union Metal Corp. (2900)	71026-B87 Rev. R11 Shts. 1, 2 & 3
	65 ft.	Ameron Pole-(2900) Prod. Div.	W3724-1 Rev. J & W3724-2 Rev. G and "J" luminaire arm
	65 ft.	Northwest Signal-(2802) Supply Inc.	NWS 3500 Rev. 4 or NWS 3500B Rev. 4
	45 ft.	American Pole (1875) Structures, Inc.	WS-T3J-L, Rev. 11 Sheets 1 & 2 of 2
	65 ft.	American Pole (2913) Structures, Inc.	WS-T3J-H, Rev. 10 Sheets 1 & 2 of 2
	65 ft.	West Coast Engineering Group	WSDOT-TS-01 Rev. 3 Sheets 1, 2, and 3
	65 ft.	Maico Industries (2947)	WSDOTMA Rev. 3 Sheets 1, 2 and 3 and "J" luminaire arm
	65 ft.	KW Industries	10-200-TSP-3 Rev. 5, Sheets 1, 2, and 3

Type IV Type IV strain pole standards shall be consistent with details in the plans and Standard Plan J-7c or one of the following pre-approved plans:

<u>Fabricator</u>	<u>Drawing No.</u>
Northwest Signal Supply Inc.	NWS 3520 Rev. 2 or NWS 3520B Rev. 2,
Valmont Industries, Inc.	DB006885, Rev. A Sheets 1 and 2
Ameron Pole Prod. Div.	M3650 Rev. G

1
2
3
4
5
6
7
8
9
10
11
12
13
14
15
16
17
18
19
20
21
22
23
24
25
26
27
28
29
30
31
32
33
34
35
36
37
38
39
40
41
42
43
44
45
46

Union Metal Corp.	EA-10224 Rev. R13 Sheet 1 of 1
American Pole Structures, Inc.	9000-12-037 Rev. A
Maico Industries	WA-SP-4 Rev.2, Sheets 1 and 2 of 2
KW Industries	10-200-SP-1 Rev. 4, Sheets 1 and 2
KW Industries	10-200-SP-2 Rev. 5, Sheets 1 and 2

Type V Type V combination strain pole and lighting standards shall be consistent with details in the plans and Standard Plan J-7c or one of the following pre-approved plans:

<u>Fabricator</u>	<u>Drawing No.</u>
Northwest Signal Supply Inc.	NWS 3520 Rev. 2 or NWS 3520B Rev. 2
Valmont Industries, Inc.	DB006885, Rev. A Sheets 1 and 2
Ameron Pole Prod. Div.	M3650 Rev. G
Union Metal Corp.	EA-10225, Rev. R13 Shts. 1 & 2
American Pole Structures, Inc.	9020-12-007 Rev. B
Maico Industries	WA-SP-5 Rev. 2 , Sheets 1, 2 & 3 and "J" luminaire arm

The luminaire arm shall be Type 1, 16 foot maximum and the luminaire mounting height shall be 40 feet or 50 feet as noted in the plans.

Type SD Type SD standards require special design. All special design shall be based on the latest AASHTO Standard Specifications for Structural Supports for Highway Signs, Luminaires and Traffic Signals and pre-approved plans and as follows:

1
2
3
4
5
6
7
8
9
10
11
12
13
14
15
16
17
18
19
20
21
22
23
24
25
26
27
28
29
30
31
32
33
34
35
36
37
38
39
40
41

1. A 90 mph wind loading shall be used.
2. The Design Life and Recurrence Interval shall be 50 years for luminaire support structures.
3. Fatigue design shall conform to AASHTO Section 11, Table 11-1 using fatigue category III.

Complete calculations for structural design, including anchor bolt details, shall be prepared by a Professional Engineer, licensed under Title 18 RCW, State of Washington, in the branch of Civil or Structural Engineering or by an individual holding valid registration in another state as a civil or structural Engineer.

All shop drawings and the cover page of all calculation submittals shall carry the Professional Engineer's original signature, date of signature, original seal, registration number, and date of expiration. The cover page shall include the contract number, contract title, and sequential index to calculation page numbers. Two copies of the associated design calculations shall be submitted for approval along with shop drawings.

Details for handholes and luminaire arm connections are available from the Bridges and Structures Office.

Foundations for various types of standards shall be as follow:

Type PPB	As noted on Standard Plan J-20.10.
Type PS	As noted on Standard Plan J-21.10-02
Type I	As noted on Standard Plan J-21.10-02
Type FB	As noted on Standard Plan J-21.10-02
Type RM	As noted on Standard Plan J-21.10-02
Type CCTV	As noted on Standard Plan J-29.15-00
Type II	As noted in the Plans.
Type III	As noted in the Plans.
Type IV	As noted in the Plans and Standard Plan J-7c.
Type V	As noted in the Plans and Standard Plan J-7c.
Type SD	As noted in the Plans.

1 **Steel Light and Signal Standards**

2 Section 9-29.6(1) is supplemented with the following:

3 *(NWR May 1, 2006)*

4 **Light and Signal Standard Painting**

5 Galvanized steel light and signal standards shall not be painted.

6 **Electrical Splice Materials**

7 Section 9-29.12 is supplemented with the following:

8 **Traffic Signal Splice Material**

9 Section 9-29.12(2) is supplemented with the following:

10 *(NWR March 1, 2011)*

11 Induction loop splices shall be either the heat shrink type or the re-enterable
12 type with end cap seals.

13 **Vehicular Signal Heads, Displays and Housing**

14 Section 9-29.16 is supplemented with the following:

15 *(NWR February 11, 2013)*

16 **Back Plate**

17 Back plates shall be constructed of louvered anodized aluminum.

18 *(NWR March 8, 2000)*

19 **Fiber Optic Signal Head**

20 A 12 inch fiber optic signal section capable of alternately displaying a yellow arrow
21 and a green arrow shall be furnished and installed where specified in the Plans.

22 **Conventional Traffic Signal Heads**

23 **Optical Units**

24 Section 9-29.16(2)A is supplemented with the following:

25 *(NWR March 8, 2004)*

26 **LED Signal Displays**

27 All traffic signal displays shall be the Light Emitting Diode (LED) type and shall
28 be from one of the following manufacturers:

29

30

1 Dialight Corporation
2 1913 Atlantic Avenue
3 Manasquan, NJ 08736
4 Telephone: (732) 223-9400
5 Fax: (732) 223-8788
6

7 GELcore, LLC
8 6810 Halle Drive
9 Valley View, OH 44125
10 Telephone: (216) 606-6555
11 Fax: (216) 606-6556
12

13 Precision Solar Controls, Inc.
14 2960 Market Street
15 Garland, TX 75041
16 Telephone: (972) 278-0553
17 Fax: (972) 271-9583
18

19 Each LED signal module shall be designed to be installed in the door frame of a
20 standard traffic signal housing. The lamp socket, reflector holder and lens used
21 with an incandescent lamp shall not be used in a signal section in which a LED
22 signal module is installed. The installation of a LED signal module shall not
23 require any modification to the housing. The LED signal module shall be a
24 single, self-contained device, not requiring onsite assembly for installation into
25 an existing traffic signal housing.
26

27 All red and yellow LED signal modules shall be manufactured with a matrix of
28 AllnGaP LED light sources and green LED signal modules shall be
29 manufactured with a matrix of InGaN LED light sources. The LED traffic signal
30 module shall be operationally compatible with controllers and conflict monitors
31 on this project. The LED lamp unit shall contain a disconnect that will show an
32 open switch to the conflict monitor when less than 60% of the LEDs in the unit
33 are operational.
34

35 Each LED module shall conform to the current standards in Institute of
36 Transportation Engineers (ITE) VTCSH Part 2 and a Certificate of Compliance
37 with these standards shall be submitted by the manufacturer for each type of
38 signal head. The certificate shall state that the lot of signal heads meets the
39 current ITE specification. A label shall be placed on each LED signal module
40 certifying conformance to this specification. The manufacturer's name,
41 trademark, serial number and other necessary identification shall be permanently
42 marked on the backside of the LED signal module. LED signal modules used on
43 this project shall be from the same manufacturer. A label shall be provided on
44 the LED housing and the Contractor shall mark the label with a permanent
45 marker to note the installation date.
46

1 The manufacturer shall provide a written warranty against defects in materials
2 and workmanship for the LED signal modules for a period of 60 months after the
3 installation of the modules. All warranty documentation shall be given to the
4 Engineer prior to installation.

5 **Traffic Signal Cover**

6 Section 9-29.16(4) is supplemented with the following:

7 *(NWR August 10, 2009)*

8 **Covering Material**

9 Signal head covering material shall consist of 4 mil minimum thickness black
10 polyethylene sheeting.

11 **Vehicle Detector**

12 Section 9-29.18 is supplemented with the following:

13 *(NWR February 11, 2013)*

14 **Loop Sealant**

15 Loop sealant for use in HMA pavement shall be one of the following:

- 16
- 17 1. RAI Pro-Seal 6006EX
 - 18 2. QCM EAS-14
 - 19 3. 3M Black 5000
 - 20 4. Craftco Inc. Part #34271
- 21

22 Loop sealant for use on concrete bridge decks and PCC pavement shall be one of the
23 following:

- 24
- 25 1. 3M Black 5000
 - 26 2. Gold Label Flex 1P
 - 27 3. QCM EAS-14

28 *(NWR July 18, 2005)*

29 **Preformed Loops**

30 Preformed detector loops shall be factory assembled. Homeruns shall be pre-wired
31 and shall be an integral part of the loop assembly. The loop configurations and
32 homerun lengths shall be assembled for the specific application shown in the Plans.

33

34 All materials used to protect the wire in the preformed loop shall have properties that
35 shall withstand the temperature and pressure of paving applications without melting
36 or cracking.

37

1 The loop and homerun shall be constructed using synthetic cord reinforced hydraulic
2 flex hose. Hose for the loop and homerun shall each be one piece. The only
3 allowable joints or splices in the hose shall be where the homeruns connect to the
4 loops.

5
6 Hose tee connections shall be high temperature synthetic rubber. The tee shall be of
7 proper size to attach directly to the hose to minimize glue joints. The tee shall have
8 the same flex properties as the hose.

9
10 The number of turns in the loop shall be as shown in the Plans. Homerun wire pairs
11 shall be twisted a minimum of two turns per foot. No wire splices shall be allowed
12 in the preformed detector loop assembly. The direction of the twist shall be
13 identified as CW for clockwise and CCW for counter clockwise twist. The loops
14 shall be available to order from the manufacturer with both twist directions available.

15
16 The loop and homeruns shall be filled and sealed with a flexible sealant. The
17 sealant, when set up, shall not soften at 180 degrees Fahrenheit, nor get brittle at
18 minus 20 degrees Fahrenheit.

19
20 All preformed detector loops shall carry a manufacturer's warranty stating that the
21 loops will be free from defects in materials and workmanship for a service period of
22 ten (10) years from the date of purchase.

23 **8-20A.3 Construction Requirements**

24 **8-20A.3(1)General**

25 Section 8-20.3(1) is supplemented with the following:

26 *(NWR May 15, 2000)*

27 **Energized Equipment**

28 Work shall be coordinated so that electrical equipment, with the exception of the
29 service cabinet, is energized within 72 hours of installation.

30 *(NWR June 20, 1995)*

31 **Pole Removal**

32 Poles designated for removal shall not be removed prior to approval of the Engineer.

33 *(NWR January 11, 2005)*

34 **Signal Display Installation**

35 Signal displays shall be installed no more than 30 days prior to scheduled signal turn
36 on or changeover.

1 *(NWR May 15, 2000)*

2 **Electrical Equipment Removals**

3 Removals associated with the electrical system shall not be stockpiled within the job
4 site without the Engineer's approval.

5 *(NWR February 11, 2013)*

6 **Contracting Agency Owned Equipment**

7 A portion of the temporary or existing electrical equipment to be removed shall
8 remain the property of the Contracting Agency.

9
10 The following shall be disconnected, dismantled, and delivered to the Contracting
11 Agency:

12
13 Doghouse style traffic signal head
14 Left Turn Yield on Green Ball Sign (R10-12)

15
16 Removed electrical equipment which remains the property of the Contracting
17 Agency shall be delivered to:

18
19 WSDOT Signal Shop
20 3700 9th Ave. So.
21 Seattle WA 98134
22 Phone: (206) 442-2110

23
24 Five days written advance notice shall be delivered to both the Engineer and the
25 Electronic Parts Specialist at the address listed above. Delivery shall occur during
26 the hours of 8:00 a.m. to 2:00 p.m. Monday through Friday. Material will not be
27 accepted without the required advance notice.

28
29 Equipment damaged during removal or delivery shall be repaired or replaced to the
30 Engineer's satisfaction at no cost to the Contracting Agency.

31
32 The Contractor shall be responsible for unloading the equipment where directed by
33 the Engineer at the delivery site.

34 *(NWR April 11, 2001)*

35 **Wire Removal**

36 Remove all wires from salvaged light and signal standards.

37

1 *(NWR April 11, 2001)*

2 **Contractor Owned Removals**

3 All removals associated with an electrical system, which are not designated to
4 remain the property of the Contracting Agency, shall become the property of the
5 Contractor and shall be removed from the project.

6
7 The Contractor shall:

8
9 Remove all wires for discontinued circuits from the conduit system.

10
11 Remove elbow sections of abandoned conduit entering junction boxes.

12
13 Abandoned conduit encountered during excavation shall be removed to the
14 nearest outlets or as directed by the Engineer.

15
16 Remove foundations entirely, unless the Plans state otherwise.

17
18 Backfill voids created by removal of foundations and junction boxes.
19 Backfilling and compaction shall be performed in accordance with
20 Section 2-09.3(1)E.

21 *(NWR May 15, 2000)*

22 **Surface Mounted Appurtenances**

23 Electrical appurtenances to be surface mounted on structures shall be mounted so
24 that a minimum 1/4 inch space is maintained between the appurtenance and
25 structure.

26 **8-20A.3(5)Conduit**

27 *(NWR June 24, 2013)*

28 **Conduit Seal**

29 Existing conduits, entering cabinets that are scheduled to have cables added or
30 removed shall be sealed with an approved mechanical plug or waterproof foam at
31 both ends of the conduit run.

32
33 Existing Outer duct and inner duct conduit, entering cabinets that are scheduled to
34 have cables added or removed shall be sealed according to this section.

35 **8-20A.3(6)Junction Boxes, Cable Vaults, and Pull boxes**

36 Section 8-20.3(6) is supplemented with the following:

1 (NWR February 11, 2013)

2 Unless otherwise noted in the Plans or approved by the Engineer, junction boxes,
3 cable vaults and pull boxes shall not be placed within the traveled way or paved
4 shoulders.

5
6 All junction boxes, cable vaults, and pull boxes placed within the traveled way or
7 paved shoulders shall be heavy-duty.

8
9 Wiring shall not be pulled into any conduit until all associated junction boxes have
10 been adjusted to, or installed in, their final grade and location, unless installation is
11 necessary to maintain system operation. If wire is installed for this reason, sufficient
12 slack shall be left to allow for future adjustment.

13
14 Prior to installing new cables or reinstalling existing cables into new or existing
15 cable vaults, pull boxes or junction boxes, the cable vault, pull box or junction box
16 shall be cleaned of all dirt and debris.

17
18 When junction boxes, cable vaults and pull boxes are installed or adjusted prior to
19 construction of finished grade, pre-molded joint filler for expansion joints may be
20 placed around the junction boxes, cable vaults, and pull boxes. The joint filler shall
21 be removed prior to adjustment to finished grade.

22
23 The six-inch gravel pad required in Standard Plan J-40.10.01 and J-40.30.00 shall be
24 maintained. When existing junction boxes do not have this gravel pad, it shall be
25 installed as part of the adjustment to finished grade.

26
27 Heavy-duty Type 4, 5 and 6 junction boxes, cable vaults, and pull boxes shall be
28 installed in accordance with the following:

- 29
- 30 1. Excavation for junction boxes, cable vaults, and pull boxes shall be sufficient
31 to leave one foot in the clear between their outer surface and the earth bank.
 - 32 2. Junction boxes, cable vaults and pull boxes shall be installed on a level 6-
33 inch layer of crushed surfacing top course, in accordance with 9-03.9(3),
34 placed on a compacted or undisturbed foundation. The crushed surfacing
35 shall be compacted in accordance with Section 2-09.3(1)E.
 - 36 3. After installation, the lid/cover shall be kept bolted down during periods
37 when work is not actively in progress at the junction box, cable vault or pull
38 box.
 - 39 4. Before closing the lid/cover, the lid/cover and the frame/ring shall be
40 thoroughly brushed and cleaned of all debris. There shall be absolutely no
41 visible dirt, sand or other foreign matter between the bearing surfaces.
 - 42 5. When the lid/cover is closed for the final time, a liberal coating of anti-seize
43 compound shall be applied to the bolts and nuts and the lid shall be securely
44 tightened.

6. Hinges on the Type 4, 5 and 6 junction boxes shall be located on the side of the box, which is nearest to adjacent shoulder. Hinges shall allow the lid to open 180 degrees.

8-20A.3(8) Wiring

Section 8-20.3(8) is supplemented with the following:

(NWR April 14, 2003)

Wire Labels

At each junction box, all illumination wires, power supply wires, and communication cable shall be labeled with a PVC marking sleeve. For illumination and power supply circuits the sleeve shall bear the circuit number. For communication cable the sleeve shall be marked "Comm."

(NWR March 13, 1995)

Wire Splices

All splices shall be made in the presence of the Engineer.

(NWR May 1, 2006)

Illumination Circuit Splices

Temporary splices shall be the heat shrink type.

(March 13, 1995)

Field Wiring Chart

501	AC+ Input	516-520 Railroad Pre-empt
502	AC- Input	5A1-5D5 Emergency Pre-empt
503-510	Control-Display	541-580 Coordination
511-515	Sign Lights	581-599 Spare

Movement Number	1	2	3	4	5	6	7	8	9
Vehicle Head									
Red	611	621	631	641	651	661	671	681	691
Yellow	612	622	632	642	652	662	672	682	692
Green	613	623	633	643	653	663	673	683	693
Spare	614	624	634	644	654	664	674	684	694
Spare	615	625	635	645	655	665	675	685	695
AC-	616	626	636	646	656	666	676	686	696
Red Auxiliary	617	627	637	647	657	667	677	687	697
Yellow Auxiliary	618	628	638	648	658	668	678	688	698
Green Auxiliary	619	629	639	649	659	669	679	689	699

1	Pedestrian Heads & Dets.									
2	Hand	711	721	731	741	751	761	771	781	791
3	Man	712	722	732	742	752	762	772	782	792
4	AC-	713	723	733	743	753	763	773	783	793
5	Detection	714	724	734	744	754	764	774	784	794
6	Common-Detection	715	725	735	745	755	765	775	785	795
7	Spare	716	726	736	746	756	766	776	786	796
8	Spare	717	727	737	747	757	767	777	787	797
9	Spare	718	728	738	748	758	768	778	788	798
10	Spare	719	729	739	749	759	769	779	789	799
11	Detection									
12	AC+	811	821	831	841	851	861	871	881	891
13	AC-	812	822	832	842	852	862	872	882	892
14	Common-Detection	813	823	833	843	853	863	873	883	893
15	Detection A	814	824	834	844	854	864	874	884	894
16	Detection B	815	825	835	845	855	865	875	885	895
17	Loop 1 Out	816	826	836	846	856	866	876	886	896
18	Loop 1 In	817	827	837	847	857	867	877	887	897
19	Loop 2 Out	818	828	838	848	858	868	878	888	898
20	Loop 2 In	819	829	839	849	859	869	879	889	899
21	Supplemental Detection									
22	Loop 3 Out	911	921	931	941	951	961	971	981	991
23	Loop 3 In	912	922	932	942	952	962	972	982	992
24	Loop 4 Out	913	923	933	943	953	963	973	983	993
25	Loop 4 In	914	924	934	944	954	964	974	984	994
26	Loop 5 Out	915	925	935	945	955	965	975	985	995
27	Loop 5 In	916	926	936	946	956	966	976	986	996
28	Loop 6 Out	917	927	937	947	957	967	977	987	997
29	Loop 6 In	918	928	938	948	958	968	978	988	998
30	Spare	919	929	939	949	959	969	979	989	999

31 **8-20A.3(9) Bonding, Grounding**

32 Section 8-20.3(9) is supplemented with the following:

33 *(NWR August 21, 2006)*

34 Where shown in the Plans or where designated by the Engineer, the metal frame and
 35 lid of existing junction boxes shall be grounded to the existing equipment grounding
 36 system. The existing equipment grounding system shall be derived from the service
 37 serving the raceway system of which the existing junction box is a part.
 38

1 **8-20A.3(11) Testing**

2 Section 8-20.3(11) is supplemented with the following:

3 *(NWR October 16, 2010)*

4 **Traffic Signal Turn-on**

5 Prior to a Traffic Signal Turn-on event, the contractor shall conduct a Pre Turn-on
6 coordination meeting with the following Contracting Agency personnel included as
7 invited attendees:

- 8
- 9 Project Engineer
- 10 Project Chief Inspector
- 11 Electrical Inspector
- 12 Signal Operations Engineer
- 13 Signal Maintenance Technician

14

15 The Contractor shall provide the Engineer a minimum of 5 days written notice of the
16 proposed Pre Turn-on coordination meeting date and time.

17

18 Prior to the Pre Turn-on coordination meeting, the Contractor shall complete the
19 items of work detailed in the Traffic Signal Turn-on Checklist and submit the
20 completed checklist to the Engineer. The Traffic Signal Turn-on Checklist form will
21 be furnished to the Contractor by the Engineer.

22

23 Prior to scheduling a turn-on date, the Contractor shall provide verification to the
24 Engineer that tests 1, 2, and 3 as specified in this section have been completed.

25 **8-20A.3(14)Signal Systems**

26 Section 8-20.3(14) is supplemented with the following:

27 **Signal Heads**

28 In Section 8-20.3(14)B the first paragraph is revised to read as follows:

29 *(NWR February 11, 2013)*

30 **Signal Heads Installation with Back Plates**

31 Signal heads shall be installed with back plates.

32

33 Where the yellow reflective tape is applied, the application surface of the
34 back plate shall be cleaned, degreased with isopropyl alcohol, and dried prior
35 to application of the sheeting.

36

1
2
3
4
5
6
7
8
9
10
11
12
13
14
15
16
17
18
19
20
21
22
23
24
25
26
27
28
29
30
31
32
33
34
35
36
37
38
39
40
41
42
43

Induction Loop Vehicle Detectors

(NWR February 22, 2005)

In Section 8-20.3(14)C, Items 2 and 11 and the last two sentences of Item 4 are deleted.

Section 8-20.3(14)C is supplemented with the following:

(NWR August 16, 2010)

Round Loops

Round loops shall be constructed in accordance with the following requirements:

1. Loop conductor and lead in cable shall conform to these Special Provisions.
2. Round sawcuts shall be six feet in diameter and shall be constructed using equipment designed for cutting round loops. The equipment shall use a concave, diamond-segmented blade. The sawcuts shall be normal to the pavement surface and shall be a minimum of 0.25 inches wide. The sawcut depth shall be a minimum of 2 5/8 inches and a maximum of three inches measured at any point along the perimeter, except on bridge decks. Other methods of constructing the round sawcut, such as anchoring a router or flat blade saw, will not be allowed.
3. The bottom of the sawcut shall be smooth. No edges created by differences in sawcut depths will be allowed.
4. All sawcut corners shall be rounded to a minimum 1.5 inch radius.
5. All sawcuts shall be cleaned with a 1000 psi high pressure washer as certified by the manufacturer's label on the machine or as measured by an in line pressure gauge. Wash water and slurry shall be vacuumed out and the sawcut shall be blown dry with compressed air. Disposal of the wash water and slurry shall comply with the requirements of Section 1-07.5(3) and the Special Provision LEGAL RELATIONS AND RESPONSIBILITIES TO THE PUBLIC.
6. Loops shall be installed after grinding and prior to the final lift of roadway surfacing material.
7. The conductor shall be installed one turn on top of the previous turn. All turns shall be installed in a clockwise direction. The conductors shall be secured to prevent floating with 2-inch lengths of high temperature foam backer rod sized for a snug fit. The backer rod shall be spaced at 2-foot intervals around the perimeter of the sawcut and at corners.

1 8. Installation of the sealant shall completely encapsulate the loop
2 conductors. A minimum of one inch of sealant shall be provided between
3 the top of the conductors and the top of the sawcut. The top of the sealant
4 shall be flush to 1/8 inch below the top of the sawcut.

5
6 9. Use of kerosene solvent is prohibited.

7 (*NWR October 5, 2009*)

8 **Existing Traffic Loops**

9 The Contractor shall notify the Area Traffic Engineer through the Engineer a
10 minimum of five working days in advance of pavement removal or grinding in areas
11 with existing loops.

12
13 If the Engineer suspects that damage to any loop, not identified in the Plans as being
14 replaced, may have resulted from Contractor's operations or is not operating
15 adequately, the Engineer may order the Contractor to perform the field tests specified
16 in Section 8 20.3(14)D. The test results shall be recorded and submitted to the
17 Engineer. Loops that fail any of these tests shall be replaced.

18
19 Loops that fail the tests, as described above, and are replaced shall be installed in
20 accordance with current WSDOT design standards and Standard Plans, as
21 determined by the Engineer.

22
23 If traffic signal loops that fail the tests, as described above, are not replaced and
24 operational within 48 hours, the Contractor shall install and maintain interim video
25 detection until the replacement loops are operational. The type of interim video
26 detection furnished shall be approved by the Engineer prior to installation.

27 **Test for Induction Loops and Lead-in Cable**

28 Section 8-20.3(14)D is supplemented with the following:

29 (*NWR October 5, 2009*)

30 **Induction Loop Tests**

31 Test A and Test D are revised as follows:

32
33 Test A – The DC resistance between the 2 lead-in cable wires, including the
34 loop, shall be measured by a volt ohmmeter. The resistance shall not exceed 5-
35 ohms or lower the Q of the circuit below 5 where Q is equal to the “Inductive
36 Impedance @ 50 kHz” divided by “Resistance”.

37
38 Test D - An inductance test shall be made to determine the inductance level of
39 each inductance loop. The Contractor shall record the inductance level of each
40 inductance loop installed on the project and shall furnish the findings to the

1 Engineer. An induction level, as measured from the controller cabinet, below
2 50-microhenries is considered a failure.

3 *(NWR October 5, 2009)*

4 **Existing Lead-in Cable Test**

5 When new induction loops are scheduled to be installed and spliced to an existing
6 two-conductor shielded detector lead-in cable, the Contractor shall perform the
7 following:

- 8
- 9 1. Disconnect the existing detector lead-in cable in the controller cabinet and at
10 the loop splice.
- 11
- 12 2. Megger test both detector lead-in cable conductors. A resistance reading of
13 less than 100-megohms is considered a failure.
- 14
- 15 3. Detector lead-in cables that fail the test shall be replaced and then retested.
- 16
- 17 4. After final testing of the detector lead-in cable, the loop installation shall be
18 completed and the loop system tested according to Tests A, C and D.
- 19
- 20 5. Connect the detector lead-in cables in the controller cabinet.

21 *(NWR February 11, 2013)*

22 **Loop Sealant**

23 Loop sealants shall be installed per manufacturer's recommendations.

24

25 3M Black 5000 sealant shall be installed so that the sealant is protected from wheel
26 tracking prior to the sealant being fully cured. When 3M Black 5000 loop sealant is
27 installed below the final lift of an HMA installation, a minimum of 5 consecutive
28 days of cure time is required before the final lift is installed.

29 *(NWR October 5, 2009)*

30 **Existing Loop Test**

31 When two-conductor shielded detector lead-in cable is scheduled to be installed and
32 spliced to an existing loop, the Contractor shall perform the following:

- 33
- 34 1. Disconnect the existing loop from the detector lead-in splice.
- 35
- 36 2. Megger test the existing loop wire. A resistance reading of less than
37 100-megohms is considered a failure.
- 38
- 39 3. Loops that fail the test shall be replaced and then retested.
- 40

1 4. After the final testing of the loops, the detector lead-in cable installation shall be
2 completed and the loop system tested according to Tests A, C and D.

3 **8-20B ILLUMINATION, TRAFFIC SIGNAL SYSTEMS, AND ELECTRICAL -**
4 **ILLUMINATION SYSTEM ONLY**

5 **8-20B.1 Description**

6 Section 8-20.1 is supplemented with the following:

7 This Work shall consist of the construction of illumination systems as shown and
8 described in the Contract Documents.

9
10 The Contractor shall provide all labor, equipment, and materials for a complete and
11 operational illumination system(s) in accordance with the Plans, WSDOT Standard
12 Specifications, WSDOT Standard Plans and these Special Provisions. Work to be
13 performed shall include, but not be limited to the following items:

- 14
15 1. The Contractor shall provide and install all underground illumination
16 components such as foundations, conduits (with pull string), ground rods,
17 junction boxes, wiring, and other hardware for the lighting systems as required
18 by the Plans and Contract Documents.
19
20 2. The Contractor shall provide and install illumination, components such as
21 service cabinet, light poles, luminaire arms, luminaires and other hardware for
22 the lighting systems as required by the Plans and Contract Documents.
23

24 The Contractor shall coordinate with Snohomish County PUD for installation or
25 modification of service connections in accordance with PUD requirements and as soon
26 as required in order to prevent project delays. PUD Contact: David Wood (360) 435-
27 7508 and Dave Lindemuth (425) 783-8202. The Contractor shall complete the PUD
28 service request form on behalf of the City and will be responsible to pay all fees to the
29 PUD associated with establishing electrical service.

30 **8-20B.1(1) Regulations and Code**

31 Section 8-20.1(1) is supplemented with the following:

32 *(March 22, 2013 *****)*

33 Where applicable, materials shall conform to the latest requirements of the Washington
34 State Department of Labor and Industries, Snohomish County Public Utilities District
35 and City of Marysville Electrical Inspector.

1 **8-20B.1(2) Industry Codes and Standards**

2 *(March 22, 2013 *****)*

3 The following is added at the end of the first paragraph of this section:

4

5 National Electrical Safety Code (NEC), Secretary NEC, NEC Committee, IEEE Post
6 Office Box 1331445 Hoes Lane, Piscataway, NJ 08855-1331.

7 **8-20B.2 Materials**

8 **8-20B.2(1) Equipment List and Drawings**

9 Section 8-20.2(1) is supplemented with the following:

10

11 Manufacturer's data for materials proposed for use in the contract which requires
12 approval shall be submitted in one complete package.

13 **8-20B.3 Construction Requirements**

14 **8-20B.3(1) General**

15 Section 8-20.3(1) is supplemented with the following:

16 **Delivery of Removed Items**

17 All salvaged signal equipment and materials, including but not limit to existing
18 controller cabinet and all its contents, signal and pedestrian displays, pedestrian
19 pushbuttons, junction boxes, Type PPB, PS, I and mast arm signal poles, preemption
20 devices, mast arm mounted signs and street light poles, arms and luminaires shall, unless
21 otherwise noted on the plans or in writing from the engineer, remain the property of the
22 City. Unless otherwise noted on the plans, all removed wiring and conduit shall become
23 the property of the contractor.

24

25 Removed electrical equipment which remains the property of the Contracting Agency
26 shall be delivered to:

27

28 City of Marysville Public Works
29 Attn: Senior Traffic Systems Control Technician
30 80 Columbia Avenue
31 Marysville, Washington 98270
32 Phone: 425-754-8289

33

34 Forty-eight (48) working hours advance notice shall be communicated to both the
35 Engineer and the Technician at the address listed above. Delivery shall occur during the
36 hours of 8:00 a.m. to 2:00 p.m. Monday through Friday. Material will not be accepted
37 without the required advance notice.

1
2
3
4
5
6
7
8
9
10
11
12
13
14
15
16
17
18
19
20
21
22
23
24
25
26
27
28
29
30
31
32
33
34
35
36

Equipment damaged during removal or delivery shall be repaired or replaced to the Engineer's satisfaction at no cost to the Contracting Agency.

The Contractor shall be responsible for unloading the equipment where directed by the Engineer or Signal Technician at the delivery site.

Contractor Owned Removals

All removals associated with an electrical system, which are not designated to remain the property of the Contracting Agency, shall become the property of the Contractor and shall be removed from the project.

The Contractor shall:

- 1. Remove all wires for discontinued circuits from the conduit system or as directed by the Engineer.
- 2. Remove elbow sections of abandoned conduit entering junction boxes or as directed by the Engineer.
- 3. Abandoned conduit encountered during excavation shall be removed to the nearest outlets or as directed by the Engineer.
- 4. Remove foundations entirely, unless the Plans state otherwise.
- 5. Backfill voids created by removal of foundations and junction boxes. Backfilling and compaction shall be performed in accordance with Section 2-19 09.3(1)E.

Section 8-20.3(1) is supplemented with the following:

(May 15, 2000 WSDOT NWR)

Energized Equipment

Work shall be coordinated so that electrical equipment, with the exception of the service cabinet, is energized within 72 hours of installation.

(June 20, 1995 WSDOT NWR)

Pole Removal

Poles designated for removal shall not be removed prior to approval of the Engineer.

- 1 1. Contact the Engineer and determine if there is an alternative location for the
2 foundation, junction box, vault or conduit trench.
- 3
- 4 2. If an adequate alternate location is not obvious for the underground Work, select a
5 location that may be acceptable and pothole to determine the exact location of other
6 utilities. Potholing must be approved by the Engineer.
- 7
- 8 3. If an adequate alternate alignment still cannot be identified following potholing
9 operations, the pothole area should be restored and Work in the area should stop until
10 a new design can be developed. See Section 1-04.7.
- 11
- 12 4. The Contractor shall not attempt to adjust the location of an existing utility unless
13 specifically agreed to by the utility owner.

14 **8-20B.3(2)A Trench and Backfill (New Section)**

15 The Contractor shall provide trenching as specified herein, regardless of the material
16 encountered, as necessary for complete and proper installation of all conduits shown in the
17 Plans. Trenching by backhoe, or shall conform to the following:

18 **Uniform Construction**

19 Trenching for conduit runs shall be done in a neat manner, and the trench bottom shall be
20 graded to provide a uniform grade. All trenches for placement of conduit shall be straight
21 and as narrow in width as practical to provide a minimum of surface disturbance. Conduits
22 shall be placed in the same trench with other conduits when possible.

23 **Trench Inspection**

24 No Work shall be covered until it has been examined by the Engineer and the Contracting
25 Agency's Electrical Inspector. Earth that fills around and over the conduit shall be free of
26 rocks greater than 2 inches up to a depth of 6 inches. When trenching is being
27 accomplished within unpaved areas, the backfill can be made with acceptable materials
28 from the excavation as approved by the Engineer and shall be considered a necessary part
29 of, and incidental to, the excavation in accordance with the Standard Specifications. The
30 compaction requirements for the Roadway backfill shall apply.

31 **Sawcut for Trench**

32 Thoroughly clean sawcuts where necessary by the use of high-pressure water (1,400 psi or
33 greater). All wastewater shall be collected and disposed of in accordance with
34 Section 1-07.15 of the Standard Specifications and these Special Provisions. Impervious
35 surfaces contaminated from cutting operations shall be cleaned in accordance with
36 Section 1-07.15 of the Standard Specifications and these Special Provisions.

37

1 **Trenching and Restoration, Other Unpaved Areas**

2 Trenches shall be placed to have minimum impact on existing landscaping and
3 irrigation systems. Any damage due to the Contractor’s operation shall be repaired or
4 replaced by the Contractor at its own expense and to the satisfaction of the Engineer.

5 **Trench Locating**

6 An orange #18AWG tracer wire shall be installed in the trench with all interconnect
7 conduits. The wire shall extend a minimum of 12 inches into each junction box and be
8 secured inside the junction box to prevent future removal from the conduit system.

9 **8-20B.3(4) Foundations**

10 Section 8-20.3(4) is supplemented with the following:

11
12 Excess materials from digging and constructing foundations shall be removed from
13 the construction site and disposed of at the Contractor’s expense.

14
15 Concrete foundations shall be placed against undisturbed earth if possible. CDF
16 shall be used to backfill around signal pole foundations that are not placed against
17 undisturbed earth. Before placing the concrete, the Contractor shall block out around
18 any other underground utilities that lie in the excavated base so that the concrete will
19 not adhere to the utility line. The Contractor shall secure the anchor bolts required
20 for the item to be mounted on the foundation. The Contractor shall also securely
21 locate all conduit required to be used to connect the pole or controller cabinet ground
22 wire to the ground rod in the nearest junction box. Concrete foundations shall be
23 troweled, brushed, edged, and finished in a workmanship-like manner. Concrete
24 shall be promptly cleaned from the exposed portion of the anchor bolts and conduit
25 after placement. Concrete and steel rebar shall be furnished and placed as shown in
26 the Standard Plans. Concrete Class 3000 shall be used for all foundations.

27
28 Where a foundation is placed adjacent to the back edge of the sidewalk, the top of
29 the foundation shall be poured flush with the finished sidewalk grade. Where round
30 foundations are allowed, the top 4 inches shall be square in shape with sides equal to
31 the diameter. If necessary, the sidewalk shall be notched around the foundation and a
32 3/4-inch through expansion joint shall be provided at all points where the foundation
33 and sidewalk are in contact, such that the foundation can be removed without
34 damage to the surrounding sidewalk. If no sidewalk exists, the top of the foundation
35 shall be as shown in the Plans.

36
37 Location of all concrete foundations shall be approved by the Engineer prior to
38 excavation.

39
40 The Contractor shall be responsible for shoring, dewatering or making any required
41 adjustments needed to install the foundation in accordance with the Plans, Standard
42 Specifications, and these Special Provisions. The Contractor shall submit their
43 approach for installing the foundations to the Engineer for approval prior to

1 constructing the foundations. No additional payment will be made for preventing
2 sloughing (i.e. casing and/or temporary shoring) or disposing of the additional
3 material from the excavation due to sloughing.

4 **8-20B.3(5) Conduit**

5 Section 8-20.3(5) is supplemented with the following:

6 *(December 16, 2014 *****)*

7 Conduits for illumination circuits systems under roadways and driveways shall be rigid
8 galvanized steel or Schedule 80 polyvinyl chloride (PVC). Schedule 40 PVC may be
9 used when not under the roadway or driveways.

10

11 All conduits shall have a minimum buried depth of twenty-four inches (24"). PVC
12 conduit ends shall have bell end PVC bushings.

13

14 Conduits for illumination circuits when under the railroad or within railroad property
15 shall be rigid galvanized steel conduit. Conduit under the tracks or within railroad
16 property shall have 48-inch minimum cover depth unless specified by the railroad
17 company. Conduit runs shall be of the same type for full length from junction box to
18 junction box.

19

20 Conduit trenches shall be straight and as narrow in width as is practical to provide a
21 minimum of pavement disturbance.

22

23 When conduit risers are installed, they shall be attached to the pole every 4 feet and shall
24 be equipped with weather heads.

25

26 Conduit for the service wires between the Snohomish County Public Utilities District
27 pole and the service panel and all above ground conduit shall be hot-dip galvanized rigid
28 steel.

29

30 Conduits shall be clearly labeled at each junction box, handhole, vault or other utility
31 appurtenance. Labeling shall be permanent and shall consist of the owner/type name
32 and a unique conduit number or color. The owner name shall be approved by the
33 Engineer prior to starting work. The recommended owner/type abbreviations are:

34

35 PUD – Snohomish County Public Utilities District

36

37 FRONTIER – Front

38

39 COMCAST(AT&T)/C – Cable

40

41 COMCAST(AT&T)/F – Fiber

42

43 SIC – City Signal Interconnect

44

45 TS – City Traffic Signal

46

47 City Spare – City spares

48

49 IL – City illumination system

1 Section 8-20.3(5) is supplemented with the following:

2 *(August 10, 2009 WSDOT NWR)*

3 **Conduit Seal, Detectable Tape and Location Wire**

4 Upon installation of wiring, all conduits entering pad mounted cabinets, all conduit
5 entering ITS hubs, and all ITS conduit 2 inches in diameter or larger shall be sealed with
6 an approved mechanical plug at both ends of the conduit run. Installation of mechanical
7 plugs shall conform to the manufacturer's recommendations. Upon installation of wiring
8 at other locations, conduit shall be sealed with duct seal. Upon installation of the pull
9 string, spare conduit shall be plugged.

10
11 A pull string rated for 200 lbs. or greater shall be installed in all spare conduits.

12
13 Detectable underground warning tape shall be placed 12-inches above all innerduct
14 installed in trenches.

15
16 Location 14 AWG stranded orange USE insulated wire shall be placed in conjunction
17 with all innerduct installed in trenches. The location wire shall be placed directly above
18 the conduit containing innerduct in single conduit installations or between the conduits
19 containing innerduct in multiple conduit installations.

20
21 Location wire routed into pull boxes or cable vaults shall be attached to the "C" channel
22 or the cover hinge bracket with stainless steel bolts and straps. A 1-foot loop of locate
23 wire shall be provided above the channel as shown in the Plans.

24 *(October 16, 2006 WSDOT NWR)*

25 **Boring**

26 In addition to the requirements for boring with casing, the Contractor shall submit to the
27 Engineer for approval a pit plan and a proposed method of boring that includes, but is
28 not limited to, the following:

- 29
- 30 1) A pit plan depicting:
 - 31 a) Protection of traffic and pedestrians.
 - 32 b) The dimension of the pit.
 - 33 c) Shoring, bracing, struts, walers or sheet piles.
 - 34 d) Type of casing.
 - 35
 - 36 2) The proposed method of boring, including:
 - 37 a) The boring system.
 - 38 b) The support system.
 - 39 c) The support system under and at the bottom of the pit.
- 40

41 The shoring and boring pit plan shall be prepared by and bear the seal and signature of a
42 Washington State licensed Professional Civil Engineer.

1 Installed casing pipe shall be free from grease, dirt, rust, moisture and any other
2 deleterious contaminants.

3
4 Commercial concrete meeting the requirements of Section 6-02.3(2)B may be used to
5 seal the casing.

6 **8-20B.3(6) Junction Boxes, Cable Vaults, and Pull Boxes**

7 All junction boxes shall be supplied by the Contractor. The locations of the junction boxes
8 as shown in the Plans are approximate and the exact locations shall be determined in the
9 field by the Engineer and Contractor. Junction boxes shall be located outside the Traveled
10 Way, wheelchair ramps and landings, and driveways. The new junction box shall not
11 interfere with any other previous or relocated installation. The lid of the junction box shall
12 be flush with its frame and with the surrounding area, whether it is shoulder, sidewalk, or
13 other surface.

14
15 Junction boxes, cable vaults and pull boxes which are placed within the sidewalk shall have
16 slip resistant lids which meet the requirements of Americans with Disabilities Act (ADA)
17 and Public Right-of-Way Accessibility Guideline (PROWAG). Approved products are:

- 18
19 1.) Mebac1 (their most aggressive surface) manufactured by IKG Industries
20
21 2.) SlipNOT Grade 3-coarse manufactured by W.S. Molnar Company.

22
23 Approved slip resistant surfaces shall have coefficient of friction of no less than 0.6 and
24 have a proven track record of outdoor application which lasts for at least 10 years.

25
26 Wiring shall not be pulled into any conduit until all associated junction boxes have been
27 adjusted to, or installed in, their final grade and location, unless installation is necessary to
28 maintain system operation. If wire is installed for this reason, sufficient slack shall be left to
29 allow for future adjustment.

30
31 When junction boxes are installed or adjusted prior to construction of finished grade, pre-
32 molded joint filler for expansion joints may be placed around the junction boxes. The joint
33 filler shall be removed prior to adjustment to finished grade.

34
35 All junction box lids shall be grounded in a manner that will allow removal of the lid
36 without breaking the ground.

37
38 The Contractor is to maintain the integrity of all junction boxes during reconfiguration of the
39 conduits, installation of new conduits or when excavating.

40
41 Heavy-duty Type 4, 5 and 6 junction boxes, cable vaults, and pull boxes shall be installed in
42 accordance with the following:

43

- 1 1. Excavation and backfill shall be in accordance with Section 2-09. Excavation for
2 junction boxes, cable vaults, and pull boxes shall be sufficient to leave one foot
3 in the clear between their outer surface and the earth bank.
- 4
- 5 2. Junction boxes, cable vaults and pull boxes shall be installed on a level 6-inch
6 layer of crushed surfacing top course, in accordance with 9-03.9(3), placed on a
7 compacted or undisturbed foundation. The crushed surfacing shall be compacted
8 in accordance with Section 2-09.3(1)E.
- 9
- 10 3. After installation, the lid/cover shall be kept bolted down during periods when
11 work is not actively in progress at the junction box, cable vault or pull box.
- 12
- 13 4. Before closing the lid/cover, the lid/cover and the frame/ring shall be thoroughly
14 brushed and cleaned of all debris. There shall be absolutely no visible dirt, sand
15 or other foreign matter between the bearing surfaces.
- 16
- 17 5. When the lid/cover is closed for the final time, a liberal coating of anti37 seize
18 compound shall be applied to the bolts and nuts and the lid shall be securely
19 tightened.
- 20
- 21 6. Hinges on the Type 4, 5 and 6 junction boxes shall be located on the side of the
22 box, which is nearest to adjacent shoulder. Hinges shall allow the lid to open 180
23 degrees.

24 **8-20B.3(8) Wiring**

25 The third paragraph of Section 8-20.3(8) is deleted and replaced with the following:

26

27 Splices in underground illumination circuits shall be installed in junction boxes. All
28 connections with #10 and smaller wire shall use compression butt joint copper crimped
29 connectors installed with a positive-action (ratchet) tool, except for quick disconnects as
30 described in Section 9-29.7. The non-insulated die shall be an indent type and the
31 insulated die shall be of a smooth shape capable of crimping pre-insulated terminals and
32 connectors. The tool shall be a compound-lever type with a ratchet mechanism to ensure
33 positive closure for the full crimping cycle. The tool shall be field adjustable to proper
34 calibration with common tools and materials. Each individual conductor shall then have
35 an approved waterproof heat-shrink tube installed, which completely covers the
36 compression connector and extends a minimum of one-half inch beyond each end of the
37 compression connector. All conductor connections shall be offset from adjacent
38 connections by a minimum of one inch. A final approved waterproof heat shrink tube
39 shall then be installed over the pair of splices in each circuit.

40

41 The second sentence in the eleventh paragraph is revised to read:

42

1 *(April 7, 2014)*

2 Every conductor at every wire termination, connector, or device shall have an approved
3 wire marking sleeve bearing, as its legend, the circuit number indicated in the Contract.

4

5 Section 8-20.3(8) is supplemented with the following:

6 *(April 14, 2003 WSDOT NWR)*

7 **Wire Labels**

8 At each junction box, all illumination wires, and power supply wires shall be labeled
9 with a PVC marking sleeve. For illumination and power supply circuits the sleeve shall
10 bear the circuit number.

11 *(May 1, 2006 WSDOT NWR)*

12 **Illumination Circuit Splices**

13 Temporary splices shall be the heat shrink type.

14 **8-20B.3(9) Bonding, Grounding**

15 Section 8-20.3(9) is supplemented with the following:

16

17 In addition to the conductors called for in the Contract, all conduit shall be installed with
18 an equipment grounding conductor sized per NEC 250-122, with the exception that the
19 minimum size shall be 8AWG.

20

21 Section 8-20.3(9) is supplemented with the following:

22 *(August 21, 2006 WSDOT NWR)*

23 **Junction Box Grounding**

24 Where shown in the Plans or where designated by the Engineer, the metal frame and lid
25 of existing junction boxes shall be grounded to the existing equipment grounding
26 system. The existing equipment grounding system shall be derived from the service
27 serving the raceway system of which the existing junction box is a part.

28 **8-21 PERMANENT SIGNING**

29 **8-21.1 Description**

30 Section 8-21.1 is deleted and replaced with the following:

1 *(March 13, 2012 *****)*

2 This work shall consist of furnishing and installing permanent signing, sign removal,
3 sign relocation, and the project sign installation and removal, in accordance with the
4 Plans, these Specifications, the Standard Plans, MUTCD, and the City of Marysville
5 Standard Details at the locations shown in the Plans or where designated by the
6 Engineer. Signs to be removed as shown on the Plans shall be returned to the Owner.

7
8 This work shall also include furnishing and installing school zone beacon assemblies.

9 **8-21.2 Materials**

10 Section 8-21.2 is modified as follows:

11
12 Sentence three is deleted and replaced with the following:

13 *(March 27, 2013 *****)*

14 Materials for sign mounting shall conform to Section 9-28.11.

15
16 Section 8-21.2 is supplemented with the following:

17
18 New ground-mounted signs shall be high intensity prismatic Type 4 with anti-graffiti
19 coating per Section 9-28.12(4) of the Special Provisions.

20
21 Overhead signing, regulatory (R series) of fluorescent yellow color, and school (S series)
22 of florescent yellow color shall meet the specifications of Type IX Micro Prismatic
23 Retroreflective Element Material sheeting in accordance with Section 9-28.12 of the
24 Standard Specifications. This standard applies to signs mounted above the roadway, on
25 span wire or signal mast arms and regulatory (R series) and school (S series) signs of
26 fluorescent yellow color. The reflectivity standard of supplemental plaques shall match
27 that of the primary sign.

28
29 Steel posts shall be Telespar 2x2 quick punch posts or approved substitute with
30 installation per the plans.

31
32 School zone beacon assemblies shall meet the requirements of Section 9-29.22.

33 **8-21.3(4) Sign Removal**

34 Section 8-21.3(4) is deleted and replaced with the following:

35
36 Where shown on the Plans, existing signs, sign posts, and sign structures shall be
37 removed by the Contractor. Wood posts to be removed shall become the property of the
38 Contractor. Metal signs and metal sign posts shall remain the property of the City and
39 shall be returned to the City Public Works Department at:

40

1 City of Marysville Public Works
2 Attn: Dean Briscoe
3 80 Columbia Avenue
4 Marysville, Washington 98270
5 Phone: 360-363-8263
6

7 Signs shall be disassembled from sign posts at time of delivery.

8 **8-22 PAVEMENT MARKING**

9 **8-22.2 Materials**

10 Section 8-22.2 is supplemented with the following:

11

12 All Plastic markings shall be Type D – Liquid cold applied methyl methacrylate.

13

1 This Page Intentionally Left Blank

**DIVISION 9
MATERIALS**

1
2
3
4
5
6
7
8
9
10
11
12
13
14
15
16
17
18
19
20
21
22
23

9-03 AGGREGATES

9-03.8 Aggregates for Hot Mix Asphalt

9-03.8(2) HMA Test Requirements

(March 10, 2010 APWA GSP)

Section 9-03.8(2) is supplemented with the following:

ESALs

The number of ESALs for the design and acceptance of the HMA shall be 3 to 30 million.

9-03.8(7) HMA Tolerances and Adjustments

(March 10, 2010 APWA GSP)

Delete Item 1 and replace it with the following:

1. **Job Mix Formula Tolerances.** After the JMF is determined as required in 5-04.3(7)A, the constituents of the mixture at the time of acceptance shall conform to the following tolerances:

	Nonstatistical Evaluation	Commercial Evaluation
Aggregate, percent passing		
1", 3/4", 1/2", and 3/8" sieves	±6%	±8%
U.S. No. 4 sieve	±6%	±8%
U.S. No. 8 sieve	±6%	±8%
U.S. No. 200 sieve	±2.0%	±3.0%
Asphalt Binder	±0.5%	±0.7%

These tolerance limits constitute the allowable limits as described in Section 1-06.2. The tolerance limit for aggregate shall not exceed the limits of the control points section, except the tolerance limits for sieves designated as 100 percent passing will be 99-100. The tolerance limits on sieves shall only apply to sieves with control points.

1 **9-15 IRRIGATION SYSTEM**

2 **9-15.6 Gate Valves**

3 Section 9-15.6 is replaced with the following:

4

5 Gate valves shall be of the type, manufacturer, and size shown on Plans.

6 **9-15.7 Control Valves**

7 **9-15.7(2) Automatic Control Valves**

8 Section 9-15.7(2) is replaced with the following:

9

10 Automatic control valves shall be of the type, manufacturer, and size shown on Plans.

11 **9-15.8 Quick Coupling Equipment**

12 Section 9-15.8 is replaced with the following:

13

14 Quick coupling valves shall be of the type, manufacturer, and size shown on Plans.

15 **9-15.9 Drain Valves**

16 Section 9-15.9 is replaced with the following:

17

18 Drain valves shall be of the type, manufacturer, and size shown on Plans.

19 **9-15.11 Cross Connection Control Devices**

20 Section 9-15.11 is replaced with the following:

21

22 Double check valve shall be of the type, manufacturer, and size shown on Plans.

23 **9-28 SIGNING MATERIALS AND FABRICATION**

24 **9-28.12 Reflective Sheeting**

25 Section 9-28.12 is supplemented with the following:

26

27 Ground-mounted signs shall be high intensity prismatic Type 4 with anti-graffiti coating
28 per Section 9-28.12(4) of the Special Provisions.

1 **9-28.12(4) Protective Overlay Film (New Section)**

2 Signs shall be overlaid with 3M protective Overlay Film 1160 or approved substitute. The
3 film provided shall meet the compatibility requirements of the manufacturer providing the
4 sign sheeting.

5 **9-29 ILLUMINATION, SIGNAL, AND ELECTRICAL**

6 **9-29.1 Conduit, Innerduct, and Outerduct**

7 Section 9-29.1 is supplemented with the following:

8 *(June 5, 2000 WSDOT NWR)*

9 **Conduit Coatings**

10 Conduit fittings for steel conduit shall be coated with galvanizing repair paint in the
11 same manner as conduit couplings. Electroplated fittings are not allowed.

12
13 Steel conduit entering concrete shall be wrapped in 2-inch-wide pipe wrap tape with a
14 minimum 1-inch overlap for 12 inches on each side of the concrete face. Pipe wrap tape
15 shall be installed per the manufacturer's recommendations.

16 **9-29.1(1) Rigid Metal Conduit, Galvanized Steel Outerduct, and Fittings**

17 Section 9-29.1(1) is supplemented with the following:

18 *(August 10, 2009 WSDOT NWR)*

19 **Conduit Sealing**

20 Mechanical plugs for cabinet conduit sealing shall be one of the following:

- 21
22 1. Tyco Electronics - TDUX
23 2. Jackmoon – Triplex Duct Plugs
24 3. O-Z Gedney – Conduit Sealing Bushings

25
26 The mechanical plug shall withstand a minimum of 5 psi of pressure.

27 **9-29.1(2) Rigid Metal Conduit Fittings and Appurtenances**

28 Section 9-29.1(2) is supplemented with the following:

29

1 *(August 10, 2009 WSDOT NWR)*

2 **Conduit Coatings**

3 Electroplated couplings are not allowed.

4 *(March 4, 2009 WSDOT NWR)*

5 **Surface Mounting Conduit Attachment Components**

6 Channel supports and all fastening hardware components shall be Type 304 stainless
7 steel.

8 **9-29.2(1) Standard Duty Junction Boxes**

9 Section 9-29.2(1) is supplemented with the following:

10 *(January 21, 2011 WSDOT NWR)*

11 **Concrete Junction Boxes**

12 The Non-slip lid and frame shall be made of the following material:

13 Non-slip lid ASTM A36 flat steel

14 Non-slip frame ASTM A36 flat steel

15 Both the non-slip lid and non-slip frame shall be treated with Mebac1 (their most
16 aggressive surface) as manufactured by IKG industries, or SlipNOT Grade 3-coarse as
17 manufactured by W.S. Molnar Co. The non-slip lid shall be identified with permanent
18 marking on the underside indicating the type of surface treatment (“M1” for Mebac 1; or
19 “S3” for SlipNot3) and the year of manufacturer. The permanent marking shall be 1/8
20 inch line thickness formed by engraving, stamping or with a stainless steel weld bead.

21 **9-29.2(1)A Standard Duty Junction Boxes**

22 Section 9-29.2(1)A, The first sentence of the second paragraph which begins "The Standard
23 Duty Concrete **Junction Box steel frame....**" **is deleted and replaced with the following:**

24

25 The Standard Duty Concrete Junction Box steel frame, lid support and lid shall be hot-
26 dip galvanized in accordance with ASTM A 111.

27 **Section 9-29.2(2)A is supplemented with the following:**

28 *(January 7, 2013)*

29 Both the slip-resistant lid and slip-resistant frame shall be treated with Mebac#1 as
30 manufactured by IKG industries, or SlipNOT Grade 3-coarse as manufactured by W.S.
31 Molnar Co. Where the exposed portion of the frame is 1/2 inch wide or less the slip-
32 resistant treatment may be omitted on that portion of the frame. The slip-resistant lid
33 shall be identified with permanent marking on the underside indicating the type of
34 surface treatment (“M1” for Mebac#1; or “S3” for SlipNOT Grade 3-coarse) and the

1 year manufactured. The permanent marking shall be 1/8 inch line thickness formed with
2 a stainless steel weld bead.

3 **9-29.3(3) Wire Marking Sleeves** **(New Section)**

4 *(WSDOT April 7, 2014)*

5 Wire marking sleeves shall be full-circle in design, non-adhesive, printable using an
6 indelible ink and shall fit snugly on the wire or cable. Marking sleeves shall be made
7 from a PVC or polyolefin, and provide permanent identification for wires and cables.

8 **9-29.6 Light and Signal Standards**

9 Section 9-29.6 is supplemented with the following:

10 *(December 17, 2013 *****)*

11 **Decorative Steel Street Light Standards**

12 All decorative street light installations shall be Philips Lumec Renaissance Series color
13 BRTX (textured bronze) or approved equal.

14

15 Phillips Lumec order shall include the below or latest model:

16

17 1. Philips Lumec Renaissance Series fixture product numbers:

18

a. RN20-90W80LED4K-ACDR-LE3R-240-BRTX

19

b. RN20-135W80LED4K-ACDR-LE3R-240-BRTX

20

c. RN20-135W80LED4K-ACDR-LE4R-240-BRTX

21

22 2. Philips Lumec pole product number SSM8V-25-BRTX including pole, access
23 door, plant support, decorative cover, ballast module, ballast tray, weld cover,
24 base cover.

25

26 3. Philips Lumec Renaissance Series mounting arm product number NM-1A-
27 BRTX.

28

29 4. Banner Arms product number BA-134

30

31 Decorative street light standards shall be furnished and installed in accordance with the
32 methods and materials noted in the applicable Standard Plans, pre-approved plans, or
33 special design plans. All welds shall comply with the latest AASHTO Standard
34 Specifications for Support of Highway Signs, Luminaires, and Traffic Signals. Welding
35 inspection shall comply with Section 6-03.3(25)A, Welding Inspection.

36

37 Decorative street light standards shall meet the following:

38

39 1. All poles and arms shall be round tapered steel.

40

1
2
3
4
5
6
7
8
9
10
11
12
13
14
15
16
17
18
19
20
21
22
23
24
25
26
27
28
29
30
31
32
33
34
35
36
37
38
39
40
41
42
43
44
45
46

2. All lamps and electrical components shall be accessible without tools.
3. Optical systems shall be IP66 rated.
4. Luminaires shall incorporate LED lamps with an L70 rated LED lamp and driver life of 100,000 hours or greater.
5. LED lamps shall have a color temperature of 4000K (+/- 350K).
6. Decorative street light standards, luminaire arms, banner arms (if required), decorative bases, and visible mounting hardware shall be of the color BRTX (textured bronze) or approved equivalent with a powder coating.
7. Anchor bolts shall be provided and installed per manufacturer recommendations.
8. All poles shall have a handhole for access to the tray-mounted ballasts.
9. All standards shall be rated to withstand 100 MPH steady wind with a gust factor of 1.3.
10. Bolt circle allowed shall be 11" @ 13".
11. All poles and luminaire arms shall incorporate decorative elements identical too or similar to those shown within the Plans.

Decorative street light standards with Banner Arms, as noted on the plans, shall meet the following:

1. Have banner arms permanently mounted at a height of 20 feet and banner arms mounted to an adjustable clamp assembly at a height of 12 feet. Banner arms shall be thirty-six (36) inches long and have a three (3) inch ball at the end.
2. Banner arm mounts shall be oriented 180 degrees from the steel arms of the luminaire.

Decorative street light standards shall be engineered by the pole manufacturer. Drawings shall be stamped by a licensed structural engineer with current valid State of Washington stamp. The foundation shall be engineered by a licensed structural engineer using pole manufacture data and project supplied soils testing report. Engineered/ stamped plans by a currently licensed structural engineer shall be submitted to the project engineer. Foundation work and pole manufacture shall not commence until engineered plans have been approved by the project engineer. Poles shall be circular in cross-section.

All poles shall have semi-flush handholes designed to avoid clearance problems with decorative bases.

1 After delivering the standards to the job site and before they are installed, they shall be
2 stored in a place that will not inconvenience the public. Standards shall be installed in
3 compliance with Washington State Utility and Electrical Codes.

4 **9-29.6(1) Steel Light and Signal Standards**

5 Section 9-29.6(1) is supplement with the following:

6 *(May 1, 2006 WSDOT NWR)*

7 **Light and Signal Standard Painting**

8 Galvanized steel light and signal standards shall not be painted.

9 **9-29.11(2) Photoelectric Control**

10 Section 9-29.11(2) is supplemented with the following:

11 *(March 27, 2013 *****)*

12 One photocell shall be installed for all luminaires in the signal system. The photocell
13 shall be located on the top of the electrical service cabinet unless otherwise specified in
14 the plans.

15 **9-29.24 Service Cabinets**

16 Section 9-29.24, Item 9 is deleted and replaced with the following:

17

18 1. Service enclosures shall be fabricated of 0.125-inch (minimum) 5052 alloy
19 aluminum H32 ASTM designator or B209 aluminum.

20

21

22

23

END SPECIAL PROVISIONS

This Page Intentionally Left Blank

APPENDIX A
AMENDMENTS TO THE STANDARD SPECIFICATIONS

1 **INTRO.AP1**

2 **INTRODUCTION**

3 The following Amendments and Special Provisions shall be used in conjunction with the
4 2014 Standard Specifications for Road, Bridge, and Municipal Construction.

5
6
7

AMENDMENTS TO THE STANDARD SPECIFICATIONS

8 The following Amendments to the Standard Specifications are made a part of this contract
9 and supersede any conflicting provisions of the Standard Specifications. For informational
10 purposes, the date following each Amendment title indicates the implementation date of the
11 Amendment or the latest date of revision.

12

13 Each Amendment contains all current revisions to the applicable section of the Standard
14 Specifications and may include references which do not apply to this particular project.

15

16 **1-01.AP1**

17 **Section 1-01, Definitions and Terms**

18 **August 4, 2014**

19 **1-01.3 Definitions**

20 The definition for "**Engineer**" is revised to read:

21

22 The Contracting Agency's representative who directly supervises the engineering and
23 administration of a construction Contract.

24

25 The definition for "**Inspector**" is revised to read:

26

27 The Engineer's representative who inspects Contract performance in detail.

28

29 The definition for "**Project Engineer**" is revised to read:

30

31 Same as Engineer.

32

33 The definition for "**Working Drawings**" is revised to read:

34

35 Drawings, plans, diagrams, or any other supplementary data or calculations, including
36 a schedule of submittal dates for Working Drawings where specified, which the
37 Contractor must submit to the Engineer.

38

39 **1-02.AP1**

40 **Section 1-02, Bid Procedures and Conditions**

41 **April 7, 2014**

42 **1-02.8(1) Noncollusion Declaration**

43 The third paragraph is revised to read:

44

1 Therefore, by including the Non-collusion Declaration as part of the signed bid
2 Proposal, the Bidder is deemed to have certified and agreed to the requirements of the
3 Declaration.
4

5 **1-03.AP1**

6 **Section 1-03, Award and Execution of Contract**
7 **January 5, 2015**

8 **1-03.3 Execution of Contract**

9 The first paragraph is revised to read:

10
11 Within 20 calendar days after the Award date, the successful Bidder shall return the
12 signed Contracting Agency-prepared Contract, an insurance certification as required
13 by Section 1-07.18, and a satisfactory bond as required by law and Section 1-03.4, and
14 shall be registered as a contractor in the state of Washington.
15

16 **1-03.4 Contract Bond**

17 The last word of item 3 is deleted.

18

19 Item 4 is renumbered to 5.

20

21 The following is inserted after item 3 (after the preceding Amendments are applied):

22

23 4. Be conditioned upon the payment of taxes, increases, and penalties incurred on
24 the project under titles 50, 51, and 82 RCW; and
25

26 **1-03.5 Failure to Execute Contract**

27 The first sentence is revised to read:

28

29 Failure to return the insurance certification and bond with the signed Contract as
30 required in Section 1-03.3, or failure to provide Disadvantaged, Minority or Women's
31 Business Enterprise information if required in the Contract, or failure or refusal to sign
32 the Contract, or failure to register as a contractor in the state of Washington shall result
33 in forfeiture of the proposal bond or deposit of this Bidder.
34

35 **1-04.AP1**

36 **Section 1-04, Scope of the Work**
37 **August 4, 2014**

38 **1-04.4 Changes**

39 In the third paragraph, item number 1 and 2 are revised to read:

40

41 A. When the character of the Work as altered differs materially in kind or nature from
42 that involved or included in the original proposed construction; or
43

44

45 B. When an item of Work, as defined elsewhere in the Contract, is increased in
excess of 125 percent or decreased below 75 percent of the original Contract

1 quantity. For the purpose of this Section, an item of Work will be defined as any
2 item that qualifies for adjustment under the provisions of Section 1-04.6.

3
4 The last two paragraphs are deleted.

5
6 This section is supplemented with the following new subsections:

7
8 **1-04.4(2) Value Engineering Change Proposal (VECP)**

9
10 **1-04.4(2)A General**

11 A VECP is a Contractor proposed change to the Contract Provisions which will
12 accomplish the projects functional requirements in a manner that is equal to or
13 better than the requirements in the Contract. The VECP may be: (1) at a less cost
14 or time, or (2) either no cost savings or a minor increase in cost with a reduction in
15 Contract time. The net savings or added costs to the Contract Work are shared by
16 the Contractor and Contracting Agency.

17
18 The Contractor may submit a VECP for changing the Plans, Specifications, or
19 other requirements of the Contract. The Engineer's decision to accept or reject all
20 or part of the proposal is final and not subject to arbitration under the arbitration
21 clause or otherwise subject to litigation.

22
23 The VECP shall meet all of the following:

- 24
25 1. Not adversely affect the long term life cycle costs.
26
27 2. Not adversely impact the ability to perform maintenance.
28
29 3. Provide the required safety and appearance.
30
31 4. Provide substitution for deleted or reduced Disadvantaged Business
32 Enterprise Condition of Award Work, Apprentice Utilization and Training.

33
34 VECPs that provide a time reduction shall meet the following requirements:

- 35
36 1. Time saving is a direct result of the VECP.
37
38 2. Liquidated damages penalties are not used to calculate savings.
39
40 3. Administrative/overhead cost savings experienced by either the
41 Contractor or Contracting Agency as a result of time reduction accrue to
42 each party and are not used to calculate savings.

43
44 **1-04.4(2)B VECP Savings**

45
46 **1-04.4(2)B1 Proposal Savings**

47 The incentive payment to the Contractor shall be one-half of the net savings
48 of the proposal calculated as follows:

- 49
50 1. (gross cost of deleted work) – (gross cost of added work) = (gross
51 savings)

1
2 2. $(\text{gross savings}) - (\text{Contractor's engineering costs}) - (\text{Contracting Agency's costs}) = (\text{net savings})$
3
4

5 3. $(\text{net savings}) / 2 = (\text{incentive pay})$
6

7 The Contracting Agency's costs shall be the actual consultant costs billed to
8 the Contracting Agency and in-house costs. Costs for personnel assigned to
9 the Engineer's office shall not be included.

10
11 **1-04.4(2)B2 Added Costs to Achieve Time Savings**

12 The cost to achieve the time savings shall be calculated as follows:
13

14 1. $(\text{cost of added work}) + (\text{Contractor's engineering costs} - \text{Contracting Agency's engineering costs}) = (\text{cost to achieve time savings})$
15
16

17 2. $(\text{cost to achieve time savings}) / 2 = (\text{Contracting Agency's share of added cost})$
18
19

20 If the timesaving proposal also involves deleting work and, as a result,
21 creates a savings for the Contracting Agency, then the Contractor shall also
22 receive one-half of the savings realized through the deletion.
23

24 **1-04.4(2)C VECP Approval**

25
26 **1-04.4(2)C1 Concept Approval**

27 The Contractor shall submit a written proposal to the Engineer for
28 consideration. The proposal shall contain the following information:
29

- 30 1. An explanation outlining the benefit provided by the change(s).
31
32 2. A narrative description of the proposed change(s). If applicable, the
33 discussion shall include a demonstration of functional equivalency or
34 a description of how the proposal meets the original contract scope of
35 work.
36
37 3. A cost discussion estimating any net savings. Savings estimates will
38 generally follow the outline below under the section, "Proposal
39 Savings".
40
41 4. A statement providing the Contracting Agency with the right to use all
42 or any part of the proposal on future projects without future obligation
43 or compensation.
44
45 5. A statement acknowledging and agreeing that the Engineer's
46 decision to accept or reject all or part of the proposal is final and not
47 subject to arbitration under the arbitration clause or otherwise be
48 subject to claims or disputes.
49
50 6. A statement giving the dates the Engineer must make a decision to
51 accept or reject the conceptual proposal, the date that approval to

1 proceed must be received, and the date the work must begin in order
2 to not delay the contract. If the Contracting Agency does not approve
3 the VECP by the date specified by the Contractor in their proposal
4 the VECP will be deemed rejected.
5

- 6 7. The submittal will include an analysis on other Work that may have
7 costs that changed as a result of the VECP. Traffic control and
8 erosion control shall both be included in addition to any other
9 impacted Work.
10

11 After review of the proposal, the Engineer will respond in writing with
12 acceptance or rejection of the concept. This acceptance shall not be
13 construed as authority to proceed with any change contract work. Concept
14 approval allows the Contractor to proceed with the Work needed to develop
15 final plans and other information to receive formal approval and to support
16 preparation of a change order.
17

18 **1-04.4(2)C2 Formal Approval**

19 The Contractor's submittal to the Engineer for formal approval shall include
20 the following:
21

- 22 1. Deleted Work – Include the calculated quantities of unit price Work to
23 be deleted. Include the proposed partial prices for portions of lump
24 sum Work deleted. For deletion of force account items include the
25 time and material estimates.
26
- 27 2. Added Work – Include the calculated quantities of unit price Work to
28 be added, either by original unit Contract prices or by new, negotiated
29 unit prices. For new items of Work include the quantities and
30 proposed prices.
31
- 32 3. Contractor's Engineering Costs – Submit the labor costs for the
33 engineering to develop the proposal; costs for Contractor employees
34 utilized in contract operations on a regular basis shall not be
35 included.
36
- 37 4. Schedule Analysis – If the VECP is related to time savings, the
38 Contractor shall submit a partial progress schedule showing the
39 changed Work. The submittal shall also include a discussion
40 comparing the partial progress schedule with the approved progress
41 schedule for the project.
42
- 43 5. Working Drawings – Type 3 Working Drawings shall be submitted;
44 those drawings which require engineering shall be a Type 3E.
45

46 Formal approval of the proposal will be documented by issuance of a change
47 order. The VECP change order will contain the following statements which
48 the Contractor agrees to by signing the change order:
49

- 50 1. The Contractor accepts design risk of all features, both temporary
51 and permanent, of the changed Work.

- 1
2
3
4
5
6
7
2. The Contractor accepts risk of constructability of the changed Work.
 3. The Contractor provides the Contracting Agency with the right to use all or any part of the proposal on future projects without further obligation or compensation.

8
9
10

VECP change orders will contain separate pay items for the items that are applicable to the Proposal. These are as follows:

- 11
12
13
14
15
16
17
18
19
1. Deleted Work.
 2. Added Work.
 3. The Contractor's engineering costs, reimbursed at 100 percent of the Contractor's cost.
 4. Incentive payment to the Contractor.

20
21
22

When added Work costs exceed Deleted Work costs, but time savings make a viable proposal, then items 3 and 4 above are replaced with the following:

- 23
24
25
26
27
3. The Contracting Agency's share of added cost to achieve time savings.
 4. The Contractor's share of savings from deleted Work.

28
29

1-04.4(2)C3 Authority to Proceed with Changed Work

30
31

The authority for the Contractor to proceed with the VECP Work will be provided by one of the following options:

- 32
33
34
35
36
37
38
39
40
41
42
43
44
45
46
47
1. Execution of the VECP change order, or
 2. At the Contractor's request the Contracting Agency may provide approval by letter from the Engineer for the Work to proceed prior to execution of a change order. All of the risk for proceeding with the VECP shall be the responsibility of the Contractor. Additionally, the following criteria are required to have been met:
 - a) Concept approval has been granted by the Contracting Agency.
 - b) All design reviews and approvals have been completed, including plans and specifications.
 - c) The Contractor has guaranteed, in writing, the minimum savings to the Contracting Agency.

1 **1-05.AP1**

2 **Section 1-05, Control of Work**

3 **August 4, 2014**

4 **1-05.1 Authority of the Engineer**

5 In this section, "Project Engineer" is revised to read "Engineer".

6

7 The second paragraph (up until the colon) is revised to read:

8

9 The Engineer's decisions will be final on all questions including the following:

10

11 The first sentence in the third paragraph is revised to read:

12

13 The Engineer represents the Contracting Agency with full authority to enforce Contract
14 requirements.

15

16 **1-05.2 Authority of Assistants and Inspectors**

17 The first paragraph is revised to read:

18

19 The Engineer may appoint assistants and Inspectors to assist in determining that the
20 Work and materials meet the Contract requirements. Assistants and Inspectors have
21 the authority to reject defective material and suspend Work that is being done
22 improperly, subject to the final decisions of the Engineer.

23

24 In the third paragraph, "Project Engineer" is revised to read "Engineer".

25

26 **1-05.3 Plans and Working Drawings**

27 This section's title is revised to read:

28

29 **Working Drawings**

30

31 This section is revised to read:

32

33 The Contract may require the Contractor to submit Working Drawings for the
34 performance of the Work. Working Drawings shall be submitted by the Contractor
35 electronically to the Engineer in PDF format; drawing details shall be prepared in
36 accordance with conventional detailing practices. If the PDF format is found to be
37 unacceptable, at the request of the Engineer, the Contractor shall provide paper copies
38 of the Working Drawings with drawings on 11 by 17 inch sheets and calculations/text
39 on 8½ by 11 inch sheets.

40

41 Working Drawings will be classified under the following categories:

42

43 1. **Type 1** – Submitted for Contracting Agency information. Submittal must be
44 received by the Contracting Agency a minimum of 7 calendar days before
45 work represented by the submittal begins.

46

47 2. **Type 2** – Submitted for Contracting Agency review and comment. Unless
48 otherwise stated in the Contract, the Engineer will require up to 20 calendar

1 days from the date the Working Drawing is received until it is returned to the
2 Contractor. The Contractor shall not proceed with the Work represented by the
3 Working Drawing until comments from the Engineer have been addressed.
4

- 5 3. **Type 2E** – Same as a Type 2 Working Drawing with Engineering as described
6 below.
7
- 8 4. **Type 3** – Submitted for Contracting Agency review and approval. Unless
9 otherwise stated in the Contract, the Engineer will require up to 30 calendar
10 days from the date the Working Drawing is received until it is returned to the
11 Contractor. The Contractor shall obtain the Engineer’s written approval before
12 proceeding with the Work represented by the Working Drawing.
13
- 14 5. **Type 3E** – Same as a Type 3 Working Drawing with Engineering as described
15 below.
16

17 All Working Drawings shall be considered Type 3 Working Drawings except as
18 specifically noted otherwise in the Contract. Unless designated otherwise by the
19 Contractor, submittals of Working Drawings will be reviewed in the order they are
20 received by the Engineer. In the event that several Working Drawings are received
21 simultaneously, the Contractor shall specify the sequence in which they are to be
22 reviewed. If the Contractor does not submit a review sequence for simultaneous
23 Working Drawing submittals, the review sequence will be at the Engineer’s discretion.
24

25 Working Drawings requiring Engineering, Type 2E and 3E, shall be prepared by (or
26 under the direction of) a Professional Engineer, licensed under Title 18 RCW, State of
27 Washington, and in accordance with WAC 196-23-020. Design calculations shall carry
28 the Professional Engineer’s signature and seal, date of signature, and registration
29 number on the cover page. The cover page shall also include the Contract number,
30 Contract title and sequential index to calculation page numbers.
31

32 If more than the specified number of days is required for the Engineer’s review of any
33 individual Working Drawing or resubmittal, an extension of time will be considered in
34 accordance with Section 1-08.8.
35

36 Review or approval of Working Drawings shall neither confer upon the Contracting
37 Agency nor relieve the Contractor of any responsibility for the accuracy of the drawings
38 or their conformity with the Contract. The Contractor shall bear all risk and all costs of
39 any Work delays caused by rejection or nonapproval of Working Drawings.
40

41 Unit Bid prices shall cover all costs of Working Drawings.
42

43 **1-07.AP1**

44 **Section 1-07, Legal Relations and Responsibilities to the Public** 45 **January 5, 2015**

46 **1-07.2 State Taxes**

47 This section is revised to read:
48

1 The Washington State Department of Revenue has issued special rules on the state
2 sales tax. Sections 1-07.2(1) through 1-07.2(3) are meant to clarify those rules. The
3 Contracting Agency will not adjust its payment if the Contractor bases a Bid on a
4 misunderstood tax liability.

5
6 The Contracting Agency may deduct from its payments to the Contractor, retainage or
7 lien the bond, in the amount the Contractor owes the State Department of Revenue,
8 whether the amount owed relates to the Contract in question or not. Any amount so
9 deducted will be paid into the proper State fund on the contractor's behalf. For
10 additional information on tax rates and application refer to applicable RCWs, WACs or
11 the Department of Revenue's website.

13 **1-07.2(1) State Sales Tax: Work Performed on City, County, or Federally- 14 Owned Land**

15 This section including title is revised to read:

17 **1-07.2(1) State Sales Tax: WAC 458-20-171 – Use Tax**

18 For Work designated as Rule 171, **Use Tax**, the Contractor shall include for
19 compensation the amount of any taxes paid in the various unit Bid prices or other
20 Contract amounts. Typically, these taxes are collected on materials incorporated into
21 the project and items such as the purchase or rental of; tools, machinery, equipment,
22 or consumable supplies not integrated into the project.

23
24 The Summary of Quantities in the Contract Plans identifies those parts of the project
25 that are subject to **Use Tax** under Section 1-07.2(1).

27 **1-07.2(2) State Sales Tax: Work on State-Owned or Private Land**

28 This section including title is revised to read:

30 **1-07.2(2) State Sales Tax: WAC 458-20-170 – Retail Sales Tax**

31 For Work designated as Rule 170, **Retail Sales Tax**, the Contractor shall collect from
32 the Contracting Agency, **Retail Sales Tax** on the full Contract price. The Contracting
33 Agency will automatically add this **Retail Sales Tax** to each payment to the Contractor
34 and for this reason; the Contractor shall not include the **Retail Sales Tax** in the unit Bid
35 prices or in any other Contract amount. However, the Contracting Agency will not
36 provide additional compensation to the Prime Contractor or Subcontractor for **Retail
37 Sales Taxes** paid by the Contractor in addition to the **Retail Sales Tax** on the total
38 contract amount. Typically, these taxes are collected on items such as the purchase or
39 rental of; tools, machinery, equipment, or consumable supplies not integrated into the
40 project. Such sales taxes shall be included in the unit Bid prices or in any other
41 Contract amounts.

42
43 The Summary of Quantities in the Contract Plans identifies those parts of the project
44 that are subject to **Retail Sales Tax** under Section 1-07.2(2).

46 **1-07.2(3) Services**

47 This section is revised to read:

48
49 Any contract wholly for professional or other applicable services is generally not
50 subject to **Retail Sales Tax** and therefore the Contractor shall not collect **Retail Sales**

1 Tax from the Contracting Agency on those Contracts. Any incidental taxes paid as part
2 of providing the services shall be included in the payments under the contract.
3

4 **1-07.23(1) Construction Under Traffic**

5 In the second paragraph, the following new sentence is inserted after the second sentence:
6

7 Accessibility to existing or temporary pedestrian push buttons shall not be impaired.
8

9 **1-08.AP1**

10 **Section 1-08, Prosecution and Progress**

11 **May 5, 2014**

12 **1-08.1 Subcontracting**

13 The eighth paragraph is revised to read:
14

15 On all projects, the Contractor shall certify to the actual amounts paid to
16 Disadvantaged, Minority, Women's, or Small Business Enterprise firms that were used
17 as Subcontractors, lower tier subcontractors, manufacturers, regular dealers, or
18 service providers on the Contract. This Certification shall be submitted to the Project
19 Engineer on a monthly basis each month between Execution of the Contract and
20 Physical Completion of the contract using the application available at:
21 <https://remoteapps.wsdot.wa.gov/mapsdata/tools/dbeparticipation>. The monthly report
22 is due 20 calendar days following the end of the month. A monthly report shall be
23 submitted for every month between Execution of the Contract and Physical Completion
24 regardless of whether payments were made or work occurred.
25

26 The ninth paragraph is deleted.
27

28 **1-09.AP1**

29 **Section 1-09, Measurement and Payment**

30 **January 5, 2015**

31 **1-09.6 Force Account**

32 In the third paragraph of item number 3, the last sentence is revised to read:
33

34 In the event that prior quotations are not obtained and the vendor is not a firm
35 independent from the Contractor or Subcontractor, then after-the-fact quotations may
36 be obtained by the Engineer from the open market in the vicinity and the lowest such
37 quotation may be used in place of submitted invoice.
38

39 **1-10.AP1**

40 **Section 1-10, Temporary Traffic Control**

41 **August 4, 2014**

42 **1-10.1(1) Materials**

43 The following material reference is deleted from this section:
44

1 Barrier Drums 9-35.8

2
3 **1-10.1(2) Description**

4 The first paragraph is revised to read:

5
6 The Contractor shall provide flaggers, and all other personnel required for labor for
7 traffic control activities and not otherwise specified as being furnished by the
8 Contracting Agency.

9
10 **1-10.2(1) General**

11 In the third paragraph, the first two sentences are revised to read:

12
13 The primary and alternate TCS shall be certified by one of the organizations listed in
14 the Special Provisions. Possession of a current Washington State TCS card and
15 flagging card by the primary and alternate TCS is mandatory.

16
17 **1-10.2(1)B Traffic Control Supervisor**

18 The first paragraph is revised to read:

19
20 A Traffic Control Supervisor (TCS) shall be present on the project whenever flagging or
21 other traffic control labor is being utilized or less frequently, as authorized by the
22 Engineer.

23
24 The last paragraph is revised to read:

25
26 The TCS may perform the Work described in Section 1-10.3(1)A Flaggers or in Section
27 1-10.3(1)B Other Traffic Control Labor and be compensated under those Bid items,
28 provided that the duties of the TCS are accomplished.

29
30 **1-10.2(2) Traffic Control Plans**

31 The first paragraph is revised to read:

32
33 The traffic control plan or plans appearing in the Contract documents show a method
34 of handling vehicle, bicycle, and pedestrian traffic. All construction signs, flaggers, and
35 other traffic control devices are shown on the traffic control plan(s) except for
36 emergency situations. If the Contractor proposes adding the use of flaggers to a plan,
37 this will constitute a modification requiring approval by the Engineer. The modified
38 plans shall show locations for all the required advance warning signs and a safe,
39 protected location for the flagging station. If flagging is to be performed during hours of
40 darkness, the plan shall include appropriate illumination for the flagging station.

41
42 In the second paragraph, the second sentence is revised to read:

43
44 Any Contractor-proposed modification, supplement or replacement shall show the
45 necessary construction signs, flaggers, and other traffic control devices required to
46 support the Work.

47
48 **1-10.2(3) Conformance to Established Standards**

49 In the second paragraph, the second sentence is revised to read:

1 The National Cooperative Highway Research Project (NCHRP) Report 350 and the
2 AASHTO Manual for Assessing Safety Hardware (MASH) have established
3 requirements for crash testing.
4

5 In the third paragraph, "NCHRP 350" is revised to read "NCHRP 350 or MASH".
6

7 In the fourth paragraph, "NCHRP 350" is revised to read "NCHRP 350 or MASH".
8

9 In the fifth paragraph, "NCHRP 350" is revised to read "NCHRP 350 or MASH".
10

11 **1-10.3(1) Traffic Control Labor**

12 The first paragraph is revised to read:
13

14 The Contractor shall furnish all personnel for flagging, for the execution of all
15 procedures related to temporary traffic control and for the setup, maintenance and
16 removal of all temporary traffic control devices and construction signs necessary to
17 control vehicular, bicycle, and pedestrian traffic during construction operations.
18

19 **1-10.3(1)A Flaggers and Spotters**

20 This section's title is revised to read:
21

22 **Flaggers**

23
24 The first paragraph is revised to read:
25

26 Flaggers shall be posted where shown on approved Traffic Control Plans or where
27 directed by the Engineer. All flaggers shall possess a current flagging card issued by
28 the State of Washington, Oregon, Montana, or Idaho. The flagging card shall be
29 immediately available and shown to the Contracting Agency upon request.
30

31 The last paragraph is deleted.
32

33 **1-10.3(1)B Other Traffic Control Labor**

34 This section is revised to read:
35

36 In addition to flagging duties, the Contractor shall provide personnel for all other traffic
37 control procedures required by the construction operations and for the labor to install,
38 maintain and remove any traffic control devices shown on Traffic Control Plans.
39

40 **1-10.3(3)B Sequential Arrow Signs**

41 This section is supplemented with the following:
42

43 A sequential arrow sign is required for all lane closure tapers on a multilane facility. A
44 separate sequential arrow sign shall be used for each closed lane. The arrow sign shall
45 not be used to laterally shift traffic. When used in the caution mode, the four corner
46 mode shall be used.
47

48 **1-10.3(3)C Portable Changeable Message Signs**

49 This section is revised to read:
50

1 Where shown on an approved traffic control plan or where ordered by the Engineer,
2 the Contractor shall provide, operate, and maintain portable changeable message
3 signs (PCMS). A PCMS shall be placed behind a barrier or guardrail whenever
4 possible, but shall at a minimum provide 4 ft. of lateral clearance to edge of travelled
5 lane and be delineated by channelization devices. The Contractor shall remove the
6 PCMS from the clear zone when not in use unless protected by barrier or guardrail.
7

8 **1-10.3(3)F Barrier Drums**

9 This section including title is deleted in its entirety and replaced with the following:
10

11 **1-10.3(3)F Vacant**

12 **1-10.3(3)K Portable Temporary Traffic Control Signal**

13 The fifth paragraph is revised to read:
14

15
16 The Project Engineer or designee will inspect the signal system at initial
17 installation/operation and approve the signal timing. Final approval will be based on the
18 results of the operational inspection.
19

20 **1-10.4(2) Item Bids With Lump Sum for Incidentals**

21 In the second paragraph, the first and second sentences are revised to read:
22

23 "Flaggers" will be measured by the hour. Hours will be measured for each flagging
24 station, shown on an approved Traffic Control Plan, when that station is staffed in
25 accordance with Section 1-10.3(1)A.
26

27 The first sentence of the last bulleted item in this section is revised to read:
28

29 Installing and removing Barricades, Traffic Safety Drums, Cones, Tubular Markers and
30 Warning Lights and Flashers to carry out approved Traffic Control Plan(s).
31

32 **1-10.5(2) Item Bids With Lump Sum for Incidentals**

33 This section is deleted and replaced with the following:
34

35 "Traffic Control Supervisor", lump sum.
36

37 The lump sum Contract payment shall be full compensation for all costs incurred by the
38 Contractor in performing the Work defined in Section 1-10.2(1)B.
39

40 "Pedestrian Traffic Control", lump sum.
41

42 The lump sum Contract payment shall be full compensation for all costs incurred by the
43 Contractor in performing the Work for pedestrian traffic control defined in Section 1-10.
44

45 "Flaggers", per hour.
46

47 The unit Contract price, when applied to the number of units measured for this item in
48 accordance with Section 1-10.4(2), shall be full compensation for all costs incurred
49 by the Contractor in performing the Work defined in Section 1-10.3(1)A.
50

1 "Other Traffic Control Labor", per hour.

2
3 The unit Contract price, when applied to the number of units measured for this item in
4 accordance with Section 1-10.4(2), shall be full compensation for all labor costs
5 incurred by the Contractor in performing the Work specified for this item in Section 1-
6 10.4(2).

7
8 "Construction Signs Class A", per square foot.

9
10 The unit Contract price, when applied to the number of units measured for this item in
11 accordance with Section 1-10.4(2), shall be full compensation for all costs incurred by
12 the Contractor in performing the Work described in Section 1-10.3(3)A. In the event
13 that "Do Not Pass" and "Pass With Care" signs must be left in place, a change order,
14 as described in Section 1-04.4, will be required. When the Bid Proposal contains the
15 item "Sign Covering", then covering those signs indicated in the Contract will be
16 measured and paid according to Section 8-21.

17
18 "Sequential Arrow Sign", per hour.

19
20 The unit Contract price, when applied to the number of units measured for this item in
21 accordance with Section 1-10.4(2), shall be full compensation for all costs incurred by
22 the Contractor in performing the Work described in Section 1-10.3(3)B.

23
24 "Portable Changeable Message Sign", per hour.

25
26 The unit Contract price, when applied to the number of units measured for this item in
27 accordance with Section 1-10.4(2), shall be full compensation for all costs incurred by
28 the Contractor in performing the Work for procuring all portable changeable message
29 signs required for the project and for transporting these signs to and from the project.

30
31 "Transportable Attenuator", per each.

32
33 The unit Contract price, when applied to the number of units measured for this item in
34 accordance with Section 1-10.4(2), shall be full compensation for all costs incurred by
35 the Contractor in performing the Work described in Section 1-10.3(3)J except for costs
36 compensated separately under the items "Operation of Transportable Attenuator" and
37 "Repair Transportable Attenuator".

38
39 "Operation of Transportable Attenuator", per hour.

40
41 The unit Contract price, when applied to the number of units measured for this item in
42 accordance with Section 1-10.4(2), shall be full compensation for all costs incurred by
43 the Contractor in performing the Work for operating transportable attenuators on the
44 project.

45
46 "Repair Transportable Attenuator", by force account.

47
48 All costs of repairing or replacing transportable attenuators that are damaged by the
49 motoring public while in use as shown on an approved Traffic Control Plan will be paid
50 for by force account as specified in Section 1-09.6. To provide a common Proposal for
51 all Bidders, the Contracting Agency has estimated the amount of force account for

1 "Repair Transportable Attenuator" and has entered the amount in the Proposal to
2 become a part of the total Bid by the Contractor. Transportable attenuators damaged
3 due to the Contractor's operation or damaged in any manner when not in use shall be
4 repaired or replaced by the Contractor at no expense to the Contracting Agency.

5
6 "Other Temporary Traffic Control", lump sum.

7
8 The lump sum Contract payment shall be full compensation for all costs incurred by the
9 Contractor in performing the Work defined in Section 1-10, and which costs are not
10 compensated by one of the above-listed items.

11
12 "Portable Temporary Traffic Control Signal", lump sum.

13
14 The lump sum Contract payment shall be full compensation for all costs incurred by the
15 Contractor in performing the Work as described in Section 1-10.3(3)K, including all
16 costs for traffic control during manual control, adjustment, malfunction, or failure of the
17 portable traffic control signals and during replacement of failed or malfunctioning
18 signals.

19
20 **2-01.AP2**

21 **Section 2-01, Clearing, Grubbing, and Roadside Cleanup**
22 **August 4, 2014**

23 **2-01.3(1) Clearing**

24 In the second paragraph, item number 3 (up until the colon) is revised to read:

- 25
26 3. Follow these requirements for all stumps that will be buried deeper than 5 feet from
27 the top, side, or end surface of the embankment or any structure and are in a
28 location that will not be terraced as described in Section 2-03.3(14):

29
30 **2-02.AP2**

31 **Section 2-02, Removal of Structures and Obstructions**
32 **January 5, 2015**

33 **2-02.3(2) Removal of Bridges, Box Culverts, and Other Drainage Structures**

34 This section is supplemented with the following new subsections:

35
36 **2-02.3(2)A Bridge Removal**

37 **2-02.3(2)A1 Bridge Demolition Plan Submittal**

38 The Contractor shall submit a Type 2E Working Drawing consisting of a bridge
39 demolition plan, showing the method of removing the existing bridge(s), or
40 portions of bridges, as specified.

41
42 The bridge demolition plan shall show all equipment, sequence of operations, and
43 details required to complete the work, including containment, collection, and
44 disposal of all debris. The plan shall include a crane foundation stability analysis
45 and crane load calculations for the work. The plan shall detail the containment,
46 collection, and disposal of all debris. The plan shall show all stages of demolition.

1
2 When the bridge removal work includes removal of a truss, and when the
3 Contractor's removal method involves use of a crane or cranes to pick, lift, and
4 remove the truss, the Contractor shall confirm the truss dead load weight prior to
5 beginning the truss removal operation. The operation of confirming the truss dead
6 load shall be performed at both ends of the truss, and shall ensure that the truss is
7 broken free of its support bearings. The Contractor's method of confirming the
8 truss dead load, whether by hydraulic jacks or other means, shall be included in
9 the Contractor's bridge demolition plan submittal.

10
11 When the bridge removal work involves removing portions of existing concrete
12 without replacement, the methods and tools used to achieve the smooth surface
13 and profile specified in Section 2-02.3(2)A2 shall be included in the Contractor's
14 bridge demolition plan submittal.

15 **2-02.3(2)A2 Removing Portions of Existing Concrete**

16 Care shall be taken in removing concrete to prevent overbreakage or damage to
17 portions of the existing Structure which are to remain. Before concrete removal
18 begins, a saw cut shall be made into the surface of the concrete at the perimeter
19 of the removal limits. The saw cut shall be 3/4-inch deep when the steel
20 reinforcement is to remain, and may be deeper when the steel reinforcement is
21 removed with the concrete.

22
23 Concrete shall be completely removed (exposing the deformed surface of the bar)
24 from existing steel reinforcing bars which extend from the existing members and
25 are specified to remain. Steel reinforcing bars that are not designated to remain
26 shall be cut a minimum of 1-inch behind the final surface. The void left by removal
27 of the steel reinforcing bar shall be filled with mortar conforming to Section 9-
28 20.4(2). The mortar shall match the color of the existing concrete surface as
29 nearly as practicable.

30
31 The Contractor shall roughen, clean, and saturate existing concrete surfaces,
32 against which fresh concrete will be placed, in accordance with Section 6-
33 02.3(12)B. When a portion of existing concrete is to be removed without
34 replacement, concrete shall be removed to a clean line with a smooth surface of
35 less than 1/16 inch profile.

36 **2-02.3(2)A3 Use of Explosives for Bridge Demolition**

37 Explosives shall not be used for bridge demolition, except as specifically allowed
38 by the Special Provisions.

39 **2-02.5 Payment**

40 This section is supplemented with the following new Bid items:

41 "Removing Existing Bridge____", lump sum.

42 "Removing Existing Structure____", lump sum.

43 "Removing Portion of Existing Bridge____", lump sum.

44 "Removing Portion of Existing Structure____", lump sum.

1
2
3
4
5
6
7
8
9
10
11
12
13
14
15
16
17
18
19
20
21
22
23
24
25
26
27
28
29
30
31
32
33
34
35
36
37
38
39

2-03.AP2

**Section 2-03, Roadway Excavation and Embankment
August 4, 2014**

2-03.3(14) Embankment Construction

The third paragraph is revised to read:

Hillside Terraces – The Contractor shall terrace the original ground or embankment when the slope of the surface is 2H:1V or steeper unless otherwise directed by the Engineer. The face of each terrace shall be a minimum of 1 foot and a maximum of 5 feet in height and shall be vertical or near vertical as required to remain stable during material placement and compaction. The bench of the terrace shall slope outward to drain and shall not be inclined steeper than 0.05 foot per foot. Terraces damaged during work shall be reestablished. The Engineer may order the Contractor to place gravel backfill, pipe drains or both to drain any seepage.

2-03.3(14)L Embankment Widening for Guardrail

The first sentence is revised to read:

Embankments widened for the installation of beam guardrail shall be terraced in accordance with the requirements for hillside terraces in Section 2-03.3(14).

The second sentence is deleted.

2-09.AP2

**Section 2-09, Structure Excavation
January 5, 2015**

2-09.4 Measurement

The seventh paragraph is revised to read:

For pipelines the lower limit in measuring structure excavation will be the foundation level as shown in the Plans or as directed by the Engineer.

2-12.AP2

**Section 2-12, Construction Geosynthetic
January 5, 2015**

2-12.3(4) Permanent Erosion Control and Ditch Lining

In the fourth paragraph, "Section 9-13.2" is revised to read "Section 9-13.1(4)".

1 **3-04.AP3**

2 **Section 3-04, Acceptance of Aggregate**
3 **April 6, 2015**

4 **3-04.5 Payment**

5 In Table 1, the "Maximum Sublot Size (Tons)" value for the item HMA Aggregate is revised
6 to read "2000".

7

8 In Table 2, the row containing the item "HMA Aggregate" is revised to read:

9

9-03.8(2)	HMA Aggregate						15	15	Uncompacted Void Content 15
-----------	---------------	--	--	--	--	--	----	----	-----------------------------------

10

11

12 **5-01.AP5**

13 **Section 5-01, Cement Concrete Pavement Rehabilitation**
14 **August 4, 2014**

15 **5-01.2 Materials**

16 The referenced section for the following item is revised to read:

17

18 Dowel Bars 9-07.5

19

20 **5-01.3(4) Replace Portland Cement Concrete Panel**

21 In the third paragraph, the last sentence is deleted.

22

23 The seventeenth paragraph (beginning with "The Contractor shall place a bond-breaking
24 material...") is deleted.

25

26 **5-02.AP5**

27 **Section 5-02, Bituminous Surface Treatment**
28 **August 4, 2014**

29 **5-02.3(11) Temporary Raised Pavement Markings**

30 This section's title is revised to read:

31

32 **Temporary Pavement Markings**

33

34 The word "raised" is deleted from this section.

35

1 **5-04.AP5**

2 **Section 5-04, Hot Mix Asphalt**
3 **April 6, 2015**

4 **5-04.2 Materials**

5 The third through eighth paragraphs are deleted and replaced with the following:
6

7 The Contractor may choose to utilize recycled asphalt pavement (RAP) or reclaimed
8 asphalt shingles (RAS) in the production of HMA. The RAP may be from pavements
9 removed under the Contract, if any, or pavement material from an existing stockpile.
10 The RAS may be from reclaimed shingles.

11
12 If greater than 20 percent RAP by total weight of HMA or any amount of RAS is utilized
13 in the production of HMA, the Contractor shall sample and test the RAP and RAS
14 during stockpile construction in accordance with WSDOT FOP for AASHTO T 308 for
15 determination of asphalt binder content and WSDOT FOP for WAQTC/AASHTO T
16 27/T 11 for gradation of the aggregates. The RAP shall be sampled and tested at a
17 frequency of one sample for every 1,000 tons produced and not less than ten samples
18 per project. The RAS shall be sampled and tested at a frequency of one sample for
19 every 100 tons produced and not less than ten samples per project. The asphalt
20 content and gradation test data shall be reported to the Contracting Agency prior to or
21 when submitting the mix design for approval on the QPL. If utilized, the amount of RAS
22 shall not exceed 5-percent of the total weight of the HMA. The Contractor shall include
23 the RAP and RAS as part of the mix design as defined in these Specifications.
24

25 The grade of asphalt binder shall be as required by the Contract. Blending of asphalt
26 binder from different sources is not permitted. For HMA with greater than 20 percent
27 RAP by total weight of HMA or any amount of RAS, the final blended asphalt binder
28 (after inclusion of RAP, RAS, new asphalt binder and recycling agent) shall be the
29 grade as required by the Contract and comply with the requirements of Section 9-
30 02.1(4).
31

32 The Contractor may only use warm mix asphalt (WMA) processes in the production of
33 HMA with 20 percent or less RAP by total weight of HMA and no RAS. The Contractor
34 shall submit to the Engineer for approval the process that is proposed and how it will
35 be used in the manufacture of HMA.
36

37 When the Contracting Agency provides aggregates or provides a source for the
38 production of aggregates, the Contract Provisions will establish the approximate
39 percentage of asphalt binder required in the mixture for each class of HMA.
40

41 Production of aggregates shall comply with the requirements of Section 3-01.
42

43 Preparation of stockpile site, the stockpiling of aggregates, and the removal of
44 aggregates from stockpiles shall comply with the requirements of Section 3-02.
45

46 **5-04.3(1) Hot Mix Asphalt Mixing Plant**

47 The first paragraph is supplemented with the following:
48

- 1 6. **Equipment for Processing RAP and RAS.** When producing HMA for mix
2 designs with greater than 20 percent RAP by total weight of HMA or any amount
3 of RAS the HMA plant shall be equipped with screens or a lump breaker to
4 eliminate oversize RAP/RAS particles from entering the pug mill or drum mixer.
5

6 **5-04.3(3)A Material Transfer Device/Vehicle**

7 The first paragraph is supplemented with the following new sentence:
8

9 At the Contractor's request the Engineer may approve paving without an MTD/V; the
10 Engineer will determine if an equitable adjustment in cost or time is due.
11

12 In the last sentence of the second paragraph, "Project Engineer" is revised to read
13 "Engineer".
14

15 **5-04.3(5)A Preparation of Existing Surfaces**

16 The first sentence of the last paragraph is revised to read:
17

18 Unless otherwise approved by the Engineer, the tack coat shall be CSS-1 or CSS-1h
19 emulsified asphalt.
20

21 **5-04.3(7) Preparation of Aggregates**

22 This section is revised to read:
23

24 The aggregates, RAP and RAS shall be stockpiled according to the requirements of
25 Section 3-02. Sufficient storage space shall be provided for each size of aggregate,
26 RAP and RAS. The Contractor may uniformly blend fine aggregate or RAP with the
27 RAS as a method of preventing the agglomeration of RAS particles. The aggregates,
28 RAP and RAS shall be removed from stockpile(s) in a manner to ensure minimal
29 segregation when being moved to the HMA plant for processing into the final mixture.
30 Different aggregate sizes shall be kept separated until they have been delivered to the
31 HMA plant.
32

33 **5-04.3(7)A1 General**

34 This section is revised to read:
35

36 An approved mix design, listed on the Qualified Products List (QPL), is required for all
37 HMA paving. The Contractor shall develop a mix design prior to the initial production of
38 HMA and no more than 3 months prior to submitting for QPL evaluation. The mix
39 design shall be developed in accordance with WSDOT Standard Operating Procedure
40 732 and meet the requirements of Sections 9-03.8(2) and 9-03.8(6).
41

42 Mix designs shall be submitted by the Contractor to the WSDOT State Materials
43 Laboratory on WSDOT Form 350-042EF. If the mix design is approved it will be listed
44 on the QPL for up to 24 consecutive months. Mix designs not listed on the QPL or past
45 the 24 month approved period shall not be used. After a mix design has been on the
46 QPL for 12 months the listing will be extended provided the Contractor submits a
47 certification letter to the Qualified Products Engineer verifying that the aggregate and
48 asphalt binder have not changed. The Contractor may submit the certification one
49 month prior to expiration of the mix design approval. Within 7 calendar days of receipt
50 of the Contractor's certification the QPL will be updated. The maximum duration for

1 approval of a mix design and listing on the QPL will be 24 months from the date of
2 initial approval or as approved by the Engineer.

3
4 Changes to the job mix formula of a mix design may require the development of a new
5 mix design and resubmittal for QPL approval. Mix designs that require resubmittal for
6 QPL approval must be approved prior to use.

7
8 Changes to aggregate that may require a new mix design include the source of
9 material or a change in the percentage of material from a stockpile greater than 5
10 percent. Changes to the percentage of material from a stockpile will be calculated
11 exclusive of the RAP content. The Contractor may vary the RAP percentage in
12 accordance with Section 5-04.2.

13
14 Changes to asphalt binder that may require a new mix design include the source of the
15 crude petroleum supplied to the refinery, the refining process, and additives or
16 modifiers in the asphalt binder.

17
18 The Contractor shall include the brand and type of anti-stripping additive in the mix
19 design submittal and provide certification from the asphalt binder manufacture that the
20 anti-stripping additive is compatible with the crude source and formulation of asphalt
21 binder proposed in the mix design. All changes to anti-strip require the submittal of a
22 new mix design for approval.

23
24 Mix designs with 20 percent RAP or less by total weight of HMA and no RAS will be
25 completed without the inclusion of the RAP. For HMA mix designs with greater than 20
26 percent RAP by total weight of HMA or any amount of RAS the Contractor shall
27 develop a mix design including RAP, RAS, recycling agent and new asphalt binder.
28 Asphalt binder contributed from RAS shall be determined in accordance with AASHTO
29 PP 78. The total quantity of asphalt binder from the RAP and RAS shall not exceed 40
30 percent of the total asphalt binder content of the HMA.

31
32 Once the RAP and RAS stockpiles have been constructed the Contractor shall extract,
33 recover and test the asphalt residue from the RAP and RAS stockpiles to determine
34 the percent of recycling agent and/or grade of new asphalt binder needed to meet the
35 grade of asphalt binder required by the contract. The asphalt extraction testing shall be
36 performed in accordance with AASHTO T 164 or ASTM D 2172 using reagent grade
37 trichloroethylene. The asphalt recovery shall be performed in accordance with
38 AASHTO R 59 or ASTM D 1856. The recovered asphalt residue shall be tested in
39 accordance with AASHTO R 29 to determine the asphalt binder grade in accordance
40 with Section 9-02.1(4). Once the recovered asphalt binder grade is determined the
41 percent of recycling agent and/or grade of new asphalt binder shall be determined in
42 accordance with ASTM D 4887. The final blend of recycling agent, recovered and new
43 asphalt shall be tested in accordance with AASHTO R 29 to confirm that it meets the
44 grade of asphalt binder required by the contract in accordance with Section 9-02.1(4).
45 All recovered and blended asphalt binder test data shall be reported to the Contracting
46 Agency prior to submitting the mix design for approval on the QPL.

47 48 **5-04.3(7)A2 Statistical or Nonstatistical Evaluation**

49 This section is revised to read:
50

1 The Contractor shall submit WSDOT Form 350-041EF to the Engineer for approval to
2 use a mix design from the QPL. The Contractor may include changes to the job mix
3 formula that have been approved on other contracts. The request to use a mix design
4 from the QPL may be rejected if production of the HMA from another contract is not in
5 compliance with Section 5-04.3(11)D.
6

7 The Contractor shall submit representative samples of the materials that are to be
8 used in the HMA production to the State Materials Laboratory in Tumwater. For HMA
9 mix designs with 20 percent RAP or less by total weight of HMA and no RAS, the
10 Contractor shall submit representative samples of the mineral materials that are to be
11 used in the HMA production; the submittal of RAP samples is not required for these
12 mix designs. For HMA mix designs with greater than 20 percent RAP by total weight of
13 HMA or any amount of RAS the Contractor shall submit representative samples of the
14 mineral materials, RAP, RAS and 100 grams of recovered asphalt residue from the
15 RAP and RAS that are to be used in the HMA production. The Contracting Agency will
16 use these samples to evaluate the mix design for approval on the QPL in accordance
17 with WSDOT Standard Practice QC-8.
18

19 **5-04.3(7)A3 Commercial Evaluation**

20 This section is revised to read:

21
22 Approval of a Commercial Evaluation mix design for listing on the QPL will be based
23 on a review of the Contractor's submittal of WSDOT Form 350-042 for conformance to
24 the requirements of Section 9-03.8(2). Testing of the HMA by the Contracting Agency
25 for mix design approval is not required. Mix designs for HMA with greater than 20
26 percent RAP by total weight of HMA or any amount of RAS may be evaluated in
27 accordance with Section 5-04.3(7)A2.
28

29 For the Bid item Commercial HMA, the Contractor shall select a class of HMA and
30 design level of Equivalent Single Axle Loads (ESAL's) appropriate for the required use.
31

32 **5-04.3(8) Mixing**

33 The first sentence of the second paragraph is revised to read:

34
35 When discharged, the temperature of the HMA shall not exceed the optimum mixing
36 temperature by more than 25°F as shown on the reference mix design report or as
37 approved by the Engineer.
38

39 The last paragraph is supplemented with the following new sentence:

40
41 After the required amount of mineral materials, RAP, RAS, new asphalt binder and
42 asphalt rejuvenator have been introduced into the mixer the HMA shall be mixed until
43 complete and uniform coating of the particles and thorough distribution of the asphalt
44 binder throughout the mineral materials, RAP and RAS is ensured.
45
46

47 **5-04.3(8)A4 Definition of Sampling and Sublot**

48 The second sentence of the second paragraph is revised to read:
49

1 The sublots shall be approximately uniform in size with a maximum subplot size based
2 on original Plan quantity tons as specified in the following table.

3
4 This section is supplemented with the following new table:

5

HMA Original Plan Quantity (tons)	Sublot Size (tons)
<20,000	1,000
20,000 to 30,000	1,500
>30,000	2,000

6
7 **5-04.3(8)A7 Test Section – HMA Mixtures**

8 This section is revised to read:

9
10 For each class of HMA accepted by statistical evaluation with 20 percent RAP or less
11 by total weight of HMA and no RAS, the Contractor may request a single test section to
12 determine whether the mixture meets the requirements of Section 9-03.8(2) and 9-
13 03.8(6). For each HMA mix design accepted by statistical evaluation with greater than
14 20 percent RAP by weight of HMA or any amount of RAS, the Contractor shall
15 construct a test section to determine whether the mixture meets the requirements of
16 Sections 9-03.8(2) and 9-03.8(6). Test sections shall be constructed at the beginning
17 of paving and will be at least 600 tons and a maximum of 1,000 tons or as approved by
18 the Engineer. For a test section to be acceptable the pay factor (PF) for gradation,
19 asphalt binder and Va shall be 0.95 or greater for each constituent and the remaining
20 test requirements in Section 9-03.8(2) (dust/asphalt ratio, sand equivalent,
21 uncompacted void and fracture) shall conform to the requirements of that section. No
22 further wearing or leveling HMA will be paved on any of the four calendar days
23 following construction of the test section. The mixture in the test section will be
24 evaluated as a lot with a minimum of three sublots required. If more than one test
25 section is required, each test section shall be a separate lot.

26
27 **5-04.3(10)A General**

28 In the first paragraph, "checking" and "cracking" are deleted.

29
30 In the third paragraph, the following new sentence is inserted after the second sentence:

31
32 Coverage with a steel wheel roller may precede pneumatic tired rolling.

33
34 In the third paragraph, the following new sentence is inserted before the last sentence:

35
36 Regardless of mix temperature, a roller shall not be operated in a mode that results in
37 checking or cracking of the mat.

38
39 **5-04.3(10)B1 General**

40 In this section, "Project Engineer" is revised to read "Engineer".

41
42 The first paragraph is revised to read:

43
44 HMA mixture accepted by statistical or nonstatistical evaluation that is used in traffic
45 lanes, including lanes for ramps, truck climbing, weaving, and speed change, and
46 having a specified compacted course thickness greater than 0.10-foot, shall be
47 compacted to a specified level of relative density. The specified level of relative density

1 shall be a Composite Pay Factor (CPF) of not less than 0.75 when evaluated in
2 accordance with Section 1-06.2, using a minimum of 91 percent of the maximum
3 density. The percent of maximum density shall be determined by WSDOT FOP for
4 AASHTO T 729 when using the nuclear density gauge and WSDOT SOP 736 when
5 using cores to determine density. The specified level of density attained will be
6 determined by the statistical evaluation of the density of the pavement.
7

8 The following four new paragraphs are inserted after the first paragraph:
9

10 Tests for the determination of the pavement density will be taken in accordance the
11 required procedures for measurement by a nuclear density gauge or roadway cores
12 after completion of the finish rolling.
13

14 If the Contracting Agency uses a nuclear density gauge to determine density the test
15 procedures FOP for WAQTC TM 8 and WSDOT SOP T 729 will be used on the day
16 the mix is placed.
17

18 Roadway cores for density may be obtained by either the Contracting Agency or the
19 Contractor in accordance with WSDOT SOP 734. The core diameter shall be 4-inches
20 unless otherwise approved by the Engineer. Roadway cores will be tested by the
21 Contracting Agency in accordance with WSDOT FOP for AASHTO T 166.
22

23 If the Contract includes the Bid item "Roadway Core" the cores shall be obtained by
24 the Contractor in the presence of the Engineer on the same day the mix is placed and
25 at locations designated by the Engineer. If the Contract does not include the Bid item
26 "Roadway Core" the Contracting Agency will obtain the cores.
27

28 In the sixth paragraph (after the preceding Amendments are applied), the second sentence
29 is revised to read:
30

31 Sublots will be uniform in size with a maximum subplot size based on original Plan
32 quantity tons of HMA as specified in the table below.
33

34 The following new table is inserted before the second to last paragraph:
35

HMA Original Plan Quantity (tons)	Sublot Size (tons)
<20,000	100
20,000 to 30,000	150
>30,000	200

36 **5-04.3(10)B4 Test Results**

37 The first paragraph is revised to read:
38
39

40 The results of all compaction acceptance testing and the CPF of the lot after three
41 sublots have been tested will be available to the Contractor through WSDOT's website.
42 Determination of the relative density of the HMA with a nuclear density gauge requires
43 a correlation factor and may require resolution after the correlation factor is known.
44 Acceptance of HMA compaction will be based on the statistical evaluation and CPF so
45 determined.
46

47 In the second paragraph, the first sentence is revised to read:

1
2 For a subplot that has been tested with a nuclear density gauge that did not meet the
3 minimum of 91 percent of the reference maximum density in a compaction lot with a
4 CPF below 1.00 and thus subject to a price reduction or rejection, the Contractor may
5 request that a core be used for determination of the relative density of the subplot.
6

7 In the second sentence of the second paragraph, "moisture-density" is revised to read
8 "density".
9

10 In the second paragraph, the fourth sentence is deleted.
11

12 **5-04.3(20) Anti-Stripping Additive**

13 This section is revised to read:
14

15 Anti-stripping additive shall be added to the liquid asphalt by the asphalt supplier prior
16 to shipment to the asphalt mixing plant. Anti-stripping additive shall be added in the
17 amount designated on the QPL for the mix design.
18

19 **5-04.4 Measurement**

20 The following new paragraph is inserted after the first paragraph:
21

22 Roadway cores will be measured per each for the number of cores taken.
23

24 The second to last paragraph is deleted.
25

26 **5-04.5 Payment**

27 The bid item "Removing Temporary Pavement Marking", per linear foot and paragraph
28 following bid item are deleted.
29

30 The following new bid item is inserted before the second to last paragraph:
31

32 "Roadway Core", per each.
33

34 The Contractor's costs for all other Work associated with the coring (e.g., traffic
35 control) shall be incidental and included within the unit Bid price per each and no
36 additional payments will be made.
37

38 **5-05.AP5**

39 **Section 5-05, Cement Concrete Pavement** 40 **April 6, 2015**

41 **5-05.3(1) Concrete Mix Design for Paving**

42 In item number 1, the first sentence of the third paragraph is revised to read:
43

44 Ground granulated blast furnace slag, if used, shall not exceed 30 percent by weight of
45 the total cementitious material and shall conform to Section 9-23.10.
46

47 The second and third rows of the table in item number 3 are revised to read:
48

Coarse Aggregate	+ 30 Pounds	- 30 Pounds
Fine Aggregate	+ 30 Pounds	- 30 Pounds

1
2
3
4
5
6
7
8
9
10
11
12
13
14
15
16
17
18
19
20
21
22
23
24
25
26
27
28
29
30
31
32
33
34
35
36
37
38
39
40
41
42
43
44

5-05.4 Measurement

The fourth paragraph is supplemented with the following new sentence:

Tie bars with drill holes in cement concrete pavement placed under the Contract will not be measured.

5-05.5 Payment

The paragraph following the Bid item "Tie Bar with Drill Hole", per each is supplemented with the following new sentence:

All costs for tie bars with drill holes in cement concrete pavement placed under the Contract shall be included in the unit Contract price per cubic yard for "Cement Conc. Pavement".

6-01.AP6

**Section 6-01, General Requirements for Structures
January 5, 2015**

6-01.6 Load Restrictions on Bridges Under Construction

The first sentence of the second paragraph is revised to read:

If necessary and safe to do so, and if the Contractor requests it through a Type 2E Working Drawing, the Engineer may allow traffic on a bridge prior to completion.

In the second paragraph, item number 3 (up until the colon) is revised to read:

- 3. Provide stress calculations under the design criteria specified in the AASHTO LRFD Bridge Design Specifications, current edition, including at a minimum the following:

6-01.9 Working Drawings

This section is revised to read:

All Working Drawings required for bridges and other Structures shall conform to Section 1-05.3.

6-01.10 Utilities Supported by or Attached to Bridges

In the second paragraph, "bridge structures" is revised to read "bridges".

6-01.14 Premolded Joint Filler

In the second paragraph, the first sentence is revised to read:

The Contractor may substitute for the nails any adhesive acceptable to the Engineer.

1 **6-02.AP6**

2 **Section 6-02, Concrete Structures**

3 **April 6, 2015**

4 **6-02.3(1) Classification of Structural Concrete**

5 In paragraph two, item number 1 is revised to read:

6

7 Mix design and proportioning specified in Sections 6-02.3(2), 6-02.3(2)A and 6-
8 02.3(2)A1.

9

10 Item number 3 is renumbered to 4.

11

12 After the preceding Amendments are applied, the following new numbered item is inserted
13 after item number 2:

14

15 3. Temperature and time for placement requirements specified in Section 6-02.3(4)D.

16

17 **6-02.3(2) Proportioning Materials**

18 In the third paragraph, the first sentence is revised to read:

19

20 The use of fly ash is required for Class 4000P concrete, except that ground granulated
21 blast furnace slag may be substituted for fly ash at a 1:1 ratio.

22

23 In the table titled "Cementitious Requirement for Concrete", the row beginning with "4000D"
24 is deleted.

25

26 The fourth paragraph is revised to read:

27

28 When both ground granulated blast furnace slag and fly ash are included in the
29 concrete mix, the total weight of both these materials is limited to 40 percent by weight
30 of the total cementitious material for concrete class 4000A, and 50 percent by weight of
31 the total cementitious material for all other classes of concrete.

32

33 **6-02.3(2)A Contractor Mix Design**

34 The first paragraph is revised to read:

35

36 The Contractor shall provide a mix design in writing to the Engineer for all classes of
37 concrete specified in the Plans except for lean concrete and commercial concrete. No
38 concrete shall be placed until the Engineer has reviewed the mix design. The required
39 average 28-day compressive strength shall be selected in accordance with ACI 301,
40 Chapter 4, Section 4.2.3.3. ACI 211.1 shall be used to determine proportions. All
41 proposed concrete mixes except Class 4000D shall meet the requirements in
42 Cementitious Requirement for Concrete in Section 6-02.3(2).

43

44 In the fourth paragraph, the fourth sentence is deleted.

45

46 In the sixth paragraph, the first sentence is deleted.

47

48 In the seventh paragraph, the last sentence is deleted.

1
2 The eighth paragraph is revised to read:

3
4 Air content for concrete Class 4000D shall conform to Section 6-02.3(2)A1. For all
5 other concrete, air content shall be a minimum of 4.5 percent and a maximum of 7.5
6 percent for all concrete placed above the finished ground line.
7

8 The following new sub-section is added:

9
10 **6-02.3(2)A1 Contractor Mix Design for Concrete Class 4000D**

11 All Class 4000D concrete shall be a project specific performance mix design
12 conforming to the following requirements:
13

- 14 1. Aggregate shall use combined gradation in accordance with Section 9-03.1(5)
15 with a nominal maximum aggregate size of 1-1/2 inches.
16
- 17 2. Permeability shall be less than 2,000 coulombs at 56 days in accordance with
18 AASHTO T 277.
19
- 20 3. Freeze-thaw durability shall be provided by one of the following methods:
21 a. The concrete shall maintain an air content between 4.5 and 7.5 percent.
22 b. The concrete shall maintain a minimum air content that achieves a
23 durability factor of 90 percent, minimum, after 300 cycles in accordance
24 with AASHTO T 161, Procedure A. This air content shall not be less than
25 3.0 percent. Test samples shall be obtained from concrete batches of a
26 minimum of 3.0 cubic yards.
27
- 28 4. Scaling shall have a visual rating less than or equal to 2 after 50 cycles in
29 accordance with ASTM C 672.
30
- 31 5. Shrinkage at 28 days shall be less than 320 micro strain in accordance with
32 AASHTO T 160.
33
- 34 6. Modulus of elasticity shall be measured in accordance with ASTM C 469.
35
- 36 7. Density shall be measured in accordance with ASTM C 138.
37

38 The Contractor shall submit the mix design in accordance with Section 6-02.3(2)A. The
39 submittal shall include test reports for all tests listed above that follow the reporting
40 requirements of the AASHTO/ASTM procedures. Samples for testing may be obtained
41 from either laboratory or concrete plant batches. If concrete plant batches are used,
42 the minimum batch size shall be 3.0 cubic yards. The Contractor shall submit the mix
43 design to the Engineer at least 30 calendar days prior to the placement of concrete in
44 the bridge deck.
45

46 **6-02.3(4)D Temperature and Time For Placement**

47 The first two sentences are revised to read:

48
49 Concrete temperatures shall remain between 55°F and 90°F while it is being placed,
50 except that Class 4000D concrete temperatures shall remain between 55°F and 75°F

1 during placement. Precast concrete that is heat cured in accordance with Section 6-
2 02.3(25)D shall remain between 50°F and 90°F while being placed.

3
4 **6-02.3(5)A General**

5 The first paragraph is revised to read:

6
7 Concrete for the following applications will be accepted based on a Certificate of
8 Compliance to be provided by the supplier as described in Section 6-02.3(5)B:

- 9
10 1. Lean concrete.
11
12 2. Commercial concrete.
13
14 3. Class 4000P concrete for Roadside Steel Sign Support Foundations.
15
16 4. Class 4000P concrete for Type II, III, and CCTV Signal Standard Foundations
17 that are 12'-0" or less in depth.
18
19 5. Class 4000P concrete for Type IV and V Strain Pole Foundations that are 12'-
20 0" or less in depth.
21
22 6. Class 4000P concrete for Steel Light Standard Foundations Types A & B.

23
24 The following new sentence is inserted at the beginning of the second paragraph:

25
26 Slip-form barrier concrete will be accepted based on conformance to the requirements
27 for temperature, air content and compressive strength at 28 days for sublots as tested
28 and determined by the Contracting Agency.
29

30 **6-02.3(5)B Certification of Compliance**

31 In the list within the first paragraph, "Fly ash (if used) brand and Type" is revised to read
32 "Fly ash (if used) brand and Class".

33
34 The first sentence of the second to last paragraph is deleted.

35
36 **6-02.3(5)G Sampling and Testing Frequency for Temperature, Consistency,
37 and Air Content**

38 In the fifth sentence of the second paragraph, "five truck loads" is revised to read "ten truck
39 loads".

40
41 The second paragraph is supplemented with the following:

42
43 If the remaining quantity to be placed is less than ten truck loads; then a sample shall
44 be randomly taken from one of the remaining truck loads.
45

46 In the last sentence of the third paragraph, "five truck loads" is revised to read "ten truck
47 loads".

48
49 **6-02.3(5)H Sampling and Testing for Compressive Strength and Initial Curing**

50 The second paragraph is revised to read:

1
2 The Contractor shall provide and maintain a sufficient number of cure boxes in
3 accordance with WSDOT FOP for AASHTO T 23 for curing concrete cylinders. The
4 cure boxes shall be readily accessible and no more than 500 feet from the point of
5 acceptance testing, unless otherwise approved by the Engineer. The Contractor shall
6 also provide, maintain and operate all necessary power sources and connections
7 needed to operate the cure boxes. The cure boxes shall be in-place and functioning at
8 the specified temperature for curing cylinders prior to concrete placement. Concrete
9 cylinders shall be cured in the cure boxes in accordance with WSDOT FOP for
10 AASHTO T 23. The cure boxes shall have working locks and the Contractor shall
11 provide the Engineer with one key to each of the locks. Once concrete cylinders are
12 placed in the cure box, the cure box shall not be disturbed until the cylinders have
13 been removed. The Contractor shall retain the cure box Temperature Measuring
14 Device log and provide it to the Engineer upon request.

15
16 The following new paragraph is inserted after the last paragraph:

17
18 All cure box costs shall be incidental to the associated item of work.

19
20 **6-02.3(6)A2 Cold Weather Protection**

21 The first sentence in the first paragraph is revised to read:

22
23 This Specification applies when the weather forecast on the day of concrete placement
24 predicts air temperatures below 35°F at any time during the 7 days following
25 placement.

26
27 The first sentence of the second paragraph is revised to read:

28
29 The temperature of the concrete shall be maintained above 50°F during the entire
30 curing period or 7 days, whichever is greater.

31
32 **6-02.3(10)A Preconstruction Meeting**

33 This section including title is revised to read:

34
35 **6-02.3(10)A Pre-Deck Pour Meeting**

36 A pre-deck pour meeting shall be held 5 to 10 working days before placing deck
37 concrete to discuss construction procedures, personnel, equipment to be used,
38 concrete sampling and testing and deck finishing and curing operations. Those
39 attending shall include, at a minimum, the superintendent, foremen in charge of placing
40 and finishing concrete, and representatives from the concrete supplier and the
41 concrete pump truck supplier.

42
43 If the project includes more than one bridge deck, and if the Contractor's key personnel
44 change between concreting operations, or at request of the Engineer, additional
45 conferences shall be held before each deck placement.

46
47 **6-02.3(10)D Concrete Placement, Finishing, and Texturing**

48 This section's content is deleted and replaced with the following new sub-sections:

49
50 **6-02.3(10)D1 Test Slab Using Bridge Deck Concrete**

1 After the Contractor receives the Engineer's approval for the Class 4000D concrete
2 mix design, and a minimum of seven calendar days prior to the first placement of
3 bridge deck concrete, the Contractor shall construct a test slab using concrete of the
4 approved mix design.

5
6 The test slab may be constructed on grade, shall have a minimum thickness of eight-
7 inches, shall have minimum plan dimensions of 10-feet along all four edges, and shall
8 be square or rectangular.

9
10 During construction of the test slab, the Contractor shall demonstrate concrete
11 sampling and testing, use of the concrete temperature monitoring system, the concrete
12 fogging system, concrete placement system, and the concrete finishing operation. The
13 Contractor shall conduct the demonstration using the same type of equipment to be
14 used for the production bridge decks, except that the Contractor may elect to finish the
15 test slab with a hand-operated strike-board.

16
17 After the construction of the test slab and the demonstration of bridge deck
18 construction operations is complete, the Contractor shall remove and dispose of the
19 test slab in accordance with Sections 2-02.3 and 2-03.3(7)C.

20 21 **6-02.3(10)D2 Preparation for Concrete Placement**

22 Before placing bridge approach slab concrete, the subgrade shall be constructed in
23 accordance with Sections 2-06 and 5-05.3(6).

24
25 Before any concrete is placed, the finishing machine shall be operated over the entire
26 length of the deck/slab to check screed deflection. Concrete placement may begin only
27 if the Engineer approves after this test.

28
29 Immediately before placing concrete, the Contractor shall check (and adjust if
30 necessary) all falsework and wedges to minimize settlement and deflection from the
31 added mass of the concrete deck/slab. The Contractor shall also install devices, such
32 as telltales, by which the Engineer can readily measure settlement and deflection.

33 34 **6-02.3(10)D3 Concrete Placement**

35 The placement operation shall cover the full width of the bridge deck or the full width
36 between construction joints. The Contractor shall locate any construction joint over a
37 beam or web that can support the deck/slab on either side of the joint. The joint shall
38 not occur over a pier unless the Plans permit. Each joint shall be formed vertically and
39 in true alignment. The Contractor shall not release falsework or wedges supporting
40 bridge deck placement sections on either side of a joint until each side has aged as
41 these Specifications require.

42
43 Placement of concrete for bridge decks and bridge approach slabs shall comply with
44 Section 6-02.3(6). In placing the concrete, the Contractor shall:

- 45
46 1. Place it (without segregation) against concrete placed earlier, as near as
47 possible to its final position, approximately to grade, and in shallow, closely
48 spaced piles;
- 49
50 2. Consolidate it around reinforcing steel by using vibrators before strike-off by
51 the finishing machine;

1
2
3
4
5
6
7
8
9
10
11
12
13
14
15
16
17
18
19
20
21
22
23
24
25
26
27
28
29
30
31
32
33
34
35
36
37
38
39
40
41
42
43
44
45
46
47
48
49
50
51

3. Not use vibrators to move concrete;
4. Not revibrate any concrete surface areas where workers have stopped prior to screeding;
5. Remove any concrete splashed onto reinforcing steel in adjacent segments before concreting them;
6. Maintain a slight excess of concrete in front of the screed across the entire width of the placement operation;
7. Operate the finishing machine to create a surface that is true and ready for final finish without overfinishing or bringing excessive amounts of mortar to the surface; and
8. Leave a thin, even film of mortar on the concrete surface after the last pass of the finishing machine pan.

Workers shall complete all post screeding operations without walking on the concrete. This may require work bridges spanning the full width of the deck/slab.

After removing the screed supports, the Contractor shall fill the voids with concrete (not mortar).

If the surface left by the finishing machine is porous, rough, or has minor irregularities, the Contractor shall float the surface of the concrete. Floating shall leave a smooth and even surface. Float finishing shall be kept to the minimum number of passes necessary to seal the surface. The floats shall be at least 4-feet long. Each transverse pass of the float shall overlap the previous pass by at least half the length of the float. The first floating shall be at right angles to the strike-off. The second floating shall be at right angles to the centerline of the span. A smooth riding surface shall be maintained across construction joints.

The edge of completed roadway slabs at expansion joints and compression seals shall have a 3/8-inch radius.

After floating, but while the concrete remains plastic, the Contractor shall test the entire deck/slab for flatness (allowing for crown, camber, and vertical curvature). The testing shall be done with a 10-foot straightedge held on the surface. The straightedge shall be advanced in successive positions parallel to the centerline, moving not more than one half the length of the straightedge each time it advances. This procedure shall be repeated with the straightedge held perpendicular to the centerline. An acceptable surface shall be one free from deviations of more than 1/8-inch under the 10-foot straightedge.

If the test reveals depressions, the Contractor shall fill them with freshly mixed concrete, strike off, consolidate, and refinish them. High areas shall be cut down and refinished. Retesting and refinishing shall continue until a surface conforming to the requirements specified above is produced.

1 **6-02.3(10)D4 Monitoring Bridge Deck Concrete Temperature After Placement**

2 The Contractor shall monitor and record the concrete temperature and ambient
3 temperature hourly for seven calendar days after placement. The Contractor shall
4 monitor and record concrete temperature by placing two maturity meter temperature
5 monitoring devices in the bridge deck at locations specified by the Engineer. The
6 Contractor shall monitor ambient temperature using maturity meters near the locations
7 where concrete temperature is being monitored. When the bridge deck is being
8 enclosed and heated to meet cold weather requirements, ambient temperature
9 readings shall be taken within the enclosure. The Contractor shall submit the concrete
10 temperature and ambient temperature data to the Engineer in spreadsheet format
11 within 14 calendar days from placing the bridge deck concrete.
12

13 The Contractor shall submit the type and model of maturity meter temperature
14 monitoring device, and the associated devices responsible for recording and
15 documenting the temperature and curing time, to the Engineer at least 14 calendar
16 days prior to the pre-concreting conference for the first bridge deck to be cast. The
17 placement and operation of the temperature monitoring devices and associated
18 devices will be an agenda item at the pre-concreting conference for the first bridge
19 deck to be cast.
20

21 **6-02.3(10)D5 Bridge Deck Concrete Finishing and Texturing**

22 Except as otherwise specified for portions of bridge decks receiving an overlay or
23 sidewalk under the same Contract, the Contractor shall texture the surface of the
24 bridge deck as follows:
25

26 The Contractor shall texture the bridge deck using diamond tipped saw blades
27 mounted on a power driven, self-propelled machine that is designed to texture
28 concrete surfaces. The grooving equipment shall provide grooves that are $1/8" \pm$
29 $1/64"$ wide, $3/16" \pm 1/16"$ deep, and spaced at $3/4" \pm 1/8"$. The bridge deck shall
30 not be textured with a metal tined comb.
31

32 The Contractor shall submit the type of grooving equipment to be used to the
33 Engineer for approval 30 calendar days prior to performing the work. The
34 Contractor shall demonstrate that the method and equipment for texturing the
35 bridge deck will not chip, spall or otherwise damage the deck. The Contractor
36 shall not begin texturing the bridge deck until receiving the Engineer's approval of
37 the Contractor's method and equipment.
38

39 Unless otherwise approved by the Engineer, the Contractor shall texture the
40 concrete bridge deck surface either in a longitudinal direction, parallel with
41 centerline or in a transverse direction, perpendicular with centerline. The
42 Contractor shall texture the bridge deck surface to within 3-inches minimum and
43 15-inches maximum of the edge of concrete at expansion joints, within 1-foot
44 minimum and 2-feet maximum of the curb line, and within 3-inches minimum and
45 9-inches maximum of the perimeter of bridge drain assemblies.
46

47 The Contractor shall contain and collect all concrete dust and debris generated by
48 the bridge deck texturing process, and shall dispose of the collected concrete dust
49 and debris in accordance with Section 2-03.3(7)C.
50

1 If the Plans call for placement of a sidewalk or an HMA or concrete overlay on the
2 bridge deck, the Contractor shall produce the final finish of these areas by dragging a
3 strip of damp, seamless burlap lengthwise over the bridge deck or by brooming it
4 lightly. Approximately 3-feet of the drag shall contact the surface, with the least
5 possible bow in its leading edge. It shall be kept wet and free of hardened lumps of
6 concrete. When the burlap drag fails to produce the required finish, the Contractor shall
7 replace it. When not in use, it shall be lifted clear of the bridge deck.
8

9 After the bridge deck has cured, the surface shall conform to the surface smoothness
10 requirements specified in Section 6-02.3(10)D3.
11

12 The surface texture on any area repaired to address out-of-tolerance surface
13 smoothness shall match closely that of the surrounding bridge deck area at the
14 completion of the repair. Methods used to remove high spots shall cut through the
15 mortar and aggregate without breaking or dislodging the aggregate or causing spalls.
16

17 **6-02.3(10)D6 Bridge Approach Slab Finishing and Texturing**

18 Bridge approach slabs shall be textured either in accordance with Section 6-
19 02.3(10)D5, or using metal tined combs in the transverse direction, except bridge
20 approach slabs receiving an overlay in the same Contract shall be finished as specified
21 in Section 6-02.3(10)D5 only.
22

23 The comb shall be made of a single row of metal tines. It shall leave striations in the
24 fresh concrete approximately 3/16-inch deep by 1/8-inch wide and spaced
25 approximately 1/2-inch apart. The Engineer will decide actual depths at the site. If the
26 comb has not been approved, the Contractor shall obtain the Engineer's approval by
27 demonstrating it on a test section. The Contractor may operate the combs manually or
28 mechanically, either singly or with several placed end to end. The timing and method
29 used shall produce the required texture without displacing larger particles of aggregate.
30

31 Texturing shall end 2-feet from curb lines. This 2-foot untextured strip shall be hand
32 finished with a steel trowel.
33

34 Surface smoothness, high spots, and low spots shall be addressed as specified in
35 Section 6-02.3(10)D5. The surface texture on any area cut down or built up shall
36 match closely that of the surrounding bridge approach slab area. The entire bridge
37 approach slab shall provide a smooth riding surface.
38

39 **6-02.3(10)F Bridge Approach Slab Orientation and Anchors**

40 In the first paragraph, the following sentence is inserted after the first sentence:
41

42 Unless otherwise shown in the Plans, the pavement end of the bridge approach slab
43 shall be constructed normal to the Roadway centerline.
44

45 The following new paragraph is inserted before the last paragraph:
46

47 The compression seal shall be a 2-1/2 inch wide gland selected from the current
48 Qualified Products List.
49

1 **6-02.3(11) Curing Concrete**

2 Items number 1 through 4 are deleted and replaced with the following 5 new numbered
3 items:

- 4
- 5 1. Bridge sidewalks, roofs of cut and cover tunnels — curing compound covered by
6 white, reflective type sheeting or continuous wet curing. Curing by either method
7 shall be for at least 10 days.
 - 8
 - 9 2. Bridge decks — See Section 6-02.3(11)B.
 - 10
 - 11 3. Bridge approach slabs (Class 4000A concrete) - 2 coats of curing compound and
12 continuous wet cure for at least 10-days.
 - 13
 - 14 4. Concrete barriers and rail bases – See Section 6-02.3(11)A.
 - 15
 - 16 5. All other concrete surfaces — continuous wet cure for at least three days.
 - 17

18 In the second paragraph, the first sentence is replaced with the following three new
19 sentences:

20

21 During the continuous wet cure, the Contractor shall keep all exposed concrete
22 surfaces saturated with water. Formed concrete surfaces shall be kept in a continuous
23 wet cure by leaving the forms in place. If forms are removed during the continuous wet
24 cure period, the Contractor shall treat the concrete as an exposed concrete surface.

25

26 The third paragraph is revised to read:

27

28 When curing Class 4000A, two coats of curing compound that complies with Section 9-
29 23.2 shall be applied immediately (not to exceed 15 min.) after tining any portion of the
30 bridge approach slab. The continuous wet cure shall be established as soon as the
31 concrete has set enough to allow covering without damaging the finish.

32

33 In the fifth paragraph, the first sentence is revised to read:

34

35 If the Plans call for an asphalt overlay on the bridge approach slab, the Contractor shall
36 use the clear curing compound (Type 1, Class B), applying at least 1 gallon per 150
37 square feet to the concrete surface.

38

39 The eighth paragraph is deleted.

40

41 **6-02.3(11)A2 Slip-Form Barrier**

42 In the fourth paragraph, item number 1, "Type 1D" is revised to read "Type 1".

43

44 **6-02.3(11)B Curing Bridge Decks**

45 This new section is supplemented with the following new sub-sections:

46

47 **6-02.3(11)B1 Equipment**

48 The Contractor shall maintain a wet sheen, without developing pooling or sheeting
49 water, using a fogging apparatus consisting of pressure washers with a minimum
50 nozzle output of 1,500 psi, or other means approved by the Engineer.

1
2 The Contractor shall submit a bridge deck curing plan to the Engineer a minimum 14
3 calendar days prior to the pre-concreting conference. The Contractor's plan shall
4 describe the sequence and timing that will be used to fog the bridge deck, apply pre-
5 soaked burlap, install soaker hoses and cover the deck with white reflective sheeting.
6

7 **6-02.3(11)B2 Curing**

8 The fogging apparatus shall be in place and charged for fogging prior to beginning
9 concrete placement for the bridge deck.

10 The Contractor shall presoak all burlap to be used to cover the deck during curing.

11
12
13 Immediately after the finishing machine passes over finished concrete, the Contractor
14 shall implement the following tasks:

- 15
16 1. The Contractor shall fog the bridge deck while maintaining a wet sheen without
17 developing pooling or sheeting water.
18
19 2. The Contractor shall apply the presoaked burlap to the top surface to fully
20 cover the deck without damaging the finish, other than minor marring of the
21 concrete surface. The Contractor shall not apply curing compound.
22
23 3. The Contractor shall continue to keep the burlap wet by fog spraying until the
24 burlap is covered by soaker hoses and white reflective sheeting. The
25 Contractor shall place the soaker hoses and whiter reflective sheeting after the
26 concrete has achieved initial set. The Contractor shall charge the soaker
27 hoses frequently so as to keep the burlap covering the entire deck wet during
28 the course of curing.
29

30 As an alternative to tasks 2 and 3 above, the Contractor may propose a curing system
31 using proprietary curing blankets specifically manufactured for bridge deck curing.
32 Details of the proprietary curing blanket system, including product literature and details
33 of how the system is to be installed and maintained, shall be submitted to the Engineer
34 for approval.
35

36 The wet curing regime as described shall remain in place for at least 14 consecutive
37 calendar days.
38

39 **6-02.3(12)A Construction Joints in New Construction**

40 The third paragraph is deleted and replaced with the following three new paragraphs:

41
42 If the Plans require a roughened surface on the joint, the Contractor shall strike it off to
43 leave grooves at right angles to the length of the member. Grooves shall be installed
44 using one of the following options:

- 45
46 1. Grooves shall be ½ to 1 inch wide, ¼ to ½ inch deep, and spaced equally at
47 twice the width of the groove. Grooves shall terminate approximately 1 ½-
48 inches from the face of concrete.
49

- 1 2. Grooves shall be 1 to 2 inches wide, a minimum of ½-inch deep, and spaced a
2 maximum of three times the width of the groove. Grooves shall terminate
3 approximately 1 ½-inches from the face of concrete.
4

5 If the Engineer approves, the Contractor may use an alternate method to produce a
6 roughened surface on the joint, provided that such an alternate method leaves a
7 roughened surface of at least a ¼-inch amplitude.
8

9 If the first strike-off does not produce the required roughness, the Contractor shall
10 repeat the process before the concrete reaches initial set. The final surface shall be
11 clean and without laitance or loose material.
12

13 **6-02.3(12)B Construction Joints Between Existing and New Construction**

14 The phrase “by method(s) as approved by the Engineer” is deleted from each paragraph in
15 this section.
16

17 **6-02.3(13) Expansion Joints**

18 The first sentence of the second paragraph is revised to read:
19

20 Joints made of a vulcanized, elastomeric compound (with neoprene as the only
21 polymer) shall be installed with a lubricant adhesive as recommended by the
22 manufacturer.
23

24 In the third paragraph, “injuring” is revised to read “damaging”.
25

26 The following two new subsections are added:
27

28 **6-02.3(13)A Strip Seal Expansion Joint System**

29 The Contractor shall submit Working Drawings consisting of the strip seal expansion
30 joint shop drawings in accordance with Section 6-03.3(7). These plans shall include, at
31 a minimum, the following:
32

- 33 1. Plan, elevation, and sections of the joint system and all components, with
34 dimensions and tolerances.
- 35 2. All material designations.
- 36 3. Manufacturer's written installation procedure.
- 37 4. Corrosion protection system used on the metal components.
- 38 5. Locations of welded shear studs, lifting mechanisms, temperature setting
39 devices, and construction adjustment devices.
- 40 6. Method of sealing the system to prevent leakage of water through the joint.

41 The strip seal shall be removable and replaceable.
42

43 The metal components shall conform to ASTM A 36, ASTM A 992, or ASTM A 572,
44 and shall be protected against corrosion by one of the following methods:
45
46
47
48
49
50

- 1
2
3
4
5
6
7
8
9
1. Zinc metallized in accordance with Section 6-07.3(14).
 2. Hot-dip galvanized in accordance with AASHTO M 111.
 3. Paint in accordance with Section 6-07.3(9). The color of the top coat shall be Federal Standard 595 Color No. 26420. The surfaces embedded in concrete shall be painted only with a shop primer coat of paint conforming to Section 9-08.1(2)C.

10
11
12
13

The strip seal gland shall be continuous for the full length of the joint with no splices permitted, unless otherwise shown in the Plans.

14
15
16
17
18

Other than items shown in the Plans, threaded studs used for construction adjustments are the only items that may be welded to the steel shapes provided they are removed by grinding after use, and the area repaired by application of an approved corrosion protection system.

19
20
21
22

If the opening between the steel shapes is anticipated to be less than 1-1/2 inches at the time of seal installation, the seal may be installed prior to encasement of the steel shapes in concrete.

23
24
25
26

After the joint system is installed, the joint shall be flooded with water and inspected, from below the joint, for leakage. If leakage is observed, the joint system shall be repaired by the Contractor, as recommended by the manufacturer.

27
28

6-02.3(13)B Compression Seal Expansion Joint System

29
30

Compression seal glands shall be selected from the current Qualified Products List and sized as shown in the Plans.

31
32
33
34
35

The compression seal expansion joint system shall be installed in accordance with the manufacturer's written recommendations. The Contractor shall submit a Type 1 Working Drawing consisting of the manufacturer's written installation procedure and repair procedures if leakage testing fails.

36
37
38
39

After the joint system is installed, the joint area shall be flooded with water and inspected, from below the joint, for leakage. If leakage is observed, the joint system shall be repaired by the Contractor, as recommended by the manufacturer.

40
41

6-02.3(14) Finishing Concrete Surfaces

42

The last sentence of the first paragraph is revised to read:

43
44

The Contractor shall clean and refinish any stained or discolored surfaces.

45
46

The following new subsection is added:

47
48

6-02.3(14)D General Requirements for Concrete Surface Finishes Produced by Form Liners

49
50
51

Horizontal and vertical joints shall be spliced in accordance with the manufacturer's printed instructions. The Contractor shall submit a Type 1 Working Drawing consisting of the manufacturer's joint splice instructions.

1
2 Horizontal splicing of ABS and plastic form liners to achieve the required height is not
3 permitted and there shall be no horizontal joints. The concrete formed with ABS and
4 plastic form liners shall be given a light sandblast to remove the glossy finish.

5
6 Side forms, traffic barrier forms, and pedestrian barrier forms using these form liners
7 may be removed after 24 hours provided the concrete mix used includes a water-
8 reducing admixture, and the concrete reaches 1,400 psi minimum compressive
9 strength before form removal. Concrete in load supporting forms utilizing these form
10 liners shall be cured in accordance with Section 6-02.3(17)N. Once the forms are
11 removed, the Contractor shall treat the joint areas by patching or light sandblasting as
12 required by the Engineer to ensure that the joints are not visible.

13
14 Form liners shall be cleaned, reconditioned, and repaired before each use. Form liners
15 with repairs, patches, or defects which, in the opinion of the Engineer, would result in
16 adverse effects to the concrete finish shall not be used.

17
18 Care shall be taken to ensure uniformity of color throughout the textured surface. A
19 change in form release agent will not be allowed.

20
21 All surfaces formed by the form liner shall also receive a Class 2 surface finish. Form
22 ties shall be a type that leaves a clean hole when removed. All spalls and form tie
23 holes shall be filled as specified for a Class 2 surface finish.

24 25 **6-02.3(14)C Pigmented Sealer for Concrete Surfaces**

26 The first sentence (up until the colon) is revised to read:

27
28 The Contractor shall submit a Type 1 Working Drawing consisting of the pigmented
29 sealer manufacturer's written instructions covering, at a minimum, the following:

30
31 The second paragraph is deleted.

32
33 In the last sentence of the third paragraph, "approval" is revised to read "acceptance".

34 35 **6-02.3(15) Date Numerals**

36 The third sentence in the first paragraph is revised to read:

37
38 When an existing Structure is widened or when traffic barrier is placed on an existing
39 Structure, the date shall be for the year in which the original Structure was completed.

40 41 **6-02.3(16) Plans for Falsework and Formwork**

42 This section is revised to read:

43
44 The Contractor shall submit all plans for falsework and formwork as Type 2E Working
45 Drawings. Submittal is not required for footing or retaining wall formwork if the wall is 4
46 feet or less in height (excluding pedestal height).

47
48 The design of falsework and formwork shall be based on:

- 1 1. Applied loads and conditions which are no less severe than those described in
2 Section 6-02.3(17)A, Design Loads;
- 3
- 4 2. Allowable stresses and deflections which are no greater than those described
5 in Section 6-02.3(17)B, Allowable Stresses and Deflections;
- 6
- 7 3. Special loads and requirements no less severe than those described in
8 Section 6-02.3(17)C, Falsework and Formwork at Special Locations;
- 9
- 10 4. Conditions required by other Sections of 6-02.3(17), Falsework and Formwork.
- 11

12 The falsework and formwork plans shall be scale drawings showing the details of
13 proposed construction, including: sizes and properties of all members and
14 components; spacing of bents, posts, studs, wales, stringers, wedges and bracing;
15 rates of concrete placement, placement sequence, direction of placement, and location
16 of construction joints; identification of falsework devices and safe working loads as well
17 as identification of any bolts or threaded rods used with the devices including their
18 diameter, length, type, grade, and required torque. The falsework plans shall show the
19 proximity of falsework to utilities or any nearby Structures including underground
20 Structures. Formwork accessories shall be identified according to Section 6-02.3(17)H,
21 Formwork Accessories. All assumptions, dimensions, material properties, and other
22 data used in making the structural analysis shall be noted on the drawing.

23
24 The Contractor shall furnish associated design calculations to the Engineer as part of
25 the submittal. The design calculations shall show the stresses and deflections in load
26 supporting members. Construction details which may be shown in the form of sketches
27 on the calculation sheets shall be shown in the falsework or formwork drawings as
28 well. Falsework or formwork plans will be rejected in cases where it is necessary to
29 refer to the calculation sheets for information needed for complete understanding of the
30 falsework and formwork plans or how to construct the falsework and formwork.

31
32 Each sheet of falsework and formwork plans shall carry the following:

- 33
- 34 1. The initials and dates of all participating design professionals.
- 35
- 36 2. Clear notation of all revisions including identification of who authorized the
37 revision, who made the revision, and the date of the revision.
- 38
- 39 3. The Contract number, Contract title, and sequential sheet number. These shall
40 also be on any related documents.
- 41
- 42 4. Identify where the falsework and formwork plan will be utilized by referencing
43 Contract Plan sheet number and related item or detail.
- 44

45 **6-02.3(16)A Nonpreapproved Falsework and Formwork Plans**

46 This section, including title, is deleted in its entirety and replaced with the following:

47 48 **6-02.3(16)A Vacant**

49 50 **6-02.3(16)B Preapproved Formwork Plans**

51 This section, including title, is revised to read:

1
2
3
4
5
6
7
8
9
10
11
12
13
14
15
16
17
18
19
20
21
22
23
24
25
26
27
28
29
30
31
32
33
34
35
36
37
38
39
40
41
42
43
44
45
46
47
48
49

6-02.3(16)B Pre-Contract Review of Falsework and Formwork Plans

The Contractor may request pre-contract review of formwork plans for abutments, wingwalls, diaphragms, retaining walls, columns, girders and beams, box culverts, railings, and bulkheads. Plans for falsework supporting the bridge deck for interior spans between precast prestressed concrete girders may also be submitted for pre-contract review.

To obtain pre-contract review, the Contractor shall electronically submit drawings and design calculations in PDF format directly to:

BridgeConstructionSupport@wsdot.wa.gov

The Bridge and Structures Office, Construction Support Engineer will return the falsework or formwork plan to the Contractor with review notes, an effective date of review, and any revisions needed prior to use. For each contract on which the pre-reviewed falsework or formwork plans will be used, the Contractor shall submit a copy to the Engineer. Construction shall not begin until the Engineer has given concurrence.

If the falsework or formwork being constructed has any deviations to the preapproved falsework or formwork plan, the Contractor shall submit plan revisions for review and approval in accordance with Section 6-02.3(16).

6-02.3(17)A Design Loads

The fifth paragraph is revised to read:

Live loads shall consist of a minimum uniform load of not less than 25 psf, applied over the entire falsework plan area, plus the greater of:

- 1. Actual weights of the deck finishing equipment applied at the rails, or;
- 2. A minimum load of 75 pounds per linear foot applied at the edge of the bridge deck.

6-02.3(17)J Face Lumber, Studs, Wales, and Metal Forms

The second and third to last paragraphs are deleted.

6-02.3(17)K Concrete Forms on Steel Spans

The second sentence of the last paragraph is revised to read:

The Contractor shall fill the holes with fully torqued ASTM A 325 bolts in accordance with Section 6-03.3(33).

6-02.3(17)O Early Concrete Test Cylinder Breaks

The third paragraph is revised to read:

The cylinders shall be cured in the field in accordance with WSDOT FOP for AASHTO T 23 Section 10.2 Field Curing.

1 **6-02.3(20) Grout for Anchor Bolts and Bridge Bearings**

2 The first five paragraphs are deleted and replaced with the following two new paragraphs:

3
4 Grout shall conform to Section 9-20.3(2) for anchor bolts and for bearing assemblies
5 with bearing plates. Grout shall conform to Section 9-20.3(3) for elastomeric bearing
6 pads and fabric pad bearings without bearing plates.

7
8 Grout shall be a workable mix with a viscosity that is suitable for the intended
9 application. The Contractor shall receive approval from the Engineer before using the
10 grout.

11
12 **6-02.3(24)C Placing and Fastening**

13 The twelfth paragraph is revised to read:

14
15 In bridge decks, a "mat" is two adjacent and perpendicular layers of reinforcing steel.
16 Top and bottom mats shall be supported adequately to hold both in their proper
17 positions. If No. 4 bars make up the lower layer of steel in a mat, it shall be blocked at
18 not more than 3-foot intervals (or 4-foot intervals for bars No. 5 and larger). Wire ties to
19 girder stirrups shall not be considered as blocking. To provide a rigid mat, the
20 Contractor shall add other supports and tie wires to the top mat as needed.

21
22 In the fourteenth paragraph, the description following "2½ inches between" is revised to
23 read:

24
25 Adjacent bars in a layer. Bridge deck and bridge approach slab bars and the top of the
26 slab.

27
28 In the fourteenth paragraph, the description following "2 inches between" is supplemented
29 with the following new sentence:

30
31 Bars and the surface of concrete when not specified otherwise in this Section or in the
32 Plans.

33
34 In the fourteenth paragraph, the first sentence in the description following "1½ inches
35 between" is deleted.

36
37 The fifteenth paragraph is revised to read:

38
39 Except for top cover in bridge decks and bridge approach slabs, cover to ties and
40 stirrups may be ½ inch less than the values specified for main bars but shall not be
41 less than 1 inch.

42
43 In the sixteenth paragraph, the first item in the second subparagraph is revised to read:

44
45 The clearance to the top surface of bridge decks
46 and bridge approach slabs +¼ in/-0".

47
48 **6-02.3(24)E Welding Reinforced Steel**

49 This section is revised to read:

1 Welding of steel reinforcing bars shall conform to the requirements of ANSI/AWS D1.4
2 Structural Welding Code - Reinforcing Steel, latest edition, except where superseded
3 by the Special Provisions, Plans, and these Specifications.
4

5 Before any welding begins, the Contractor shall submit a Type 2 Working Drawing
6 consisting of the welding procedure for each type of welded splice to be used,
7 including the weld procedure specifications and joint details. The weld procedure
8 specifications shall be written on a form taken from AWS D1.4 Annex A, or equivalent.
9 Test results of tensile strength, macroetch, and visual examination shall be included.
10 The form shall be signed and dated.

11
12 Welders shall be qualified in accordance with AWS D1.4. The Contractor shall be
13 responsible for the testing and qualification of welders, and shall submit Type 2
14 Working Drawings consisting of welder qualification and retention records. The weld
15 joint and welding position a welder is qualified in shall be in accordance with AWS
16 D1.4. The welder qualifications shall remain in effect indefinitely unless, (1) the welder
17 is not engaged in a given process of welding for which the welder is qualified for a
18 period exceeding six months, or (2) there is some specific reason to question a
19 welder's ability.
20

21 Filler metals used for welding reinforcing bars shall be in accordance with AWS D1.4
22 Table 5.1. All filler metals shall be low-hydrogen and handled in compliance with low-
23 hydrogen practices specified in the AWS code.
24

25 Short circuiting transfer with gas metal arc welding will not be allowed. Slugging of
26 welds will not be allowed.
27

28 For the purpose of compatibility with AWS D1.4, welded lap splices for spiral or hoop
29 reinforcing shall be considered Flare-V groove welds, indirect butt joints.
30

31 The Contractor is responsible for using a welding sequence that will limit the alignment
32 distortion of the bars due to the effects of welding. The maximum out-of-line permitted
33 will be 1/4 inch from a 3.5-foot straight-edge centered on the weld and in line with the
34 bar.
35

36 The ground wire from the welding machine shall be clamped to the bar being welded.
37

38 Where epoxy-coated steel reinforcing bars are specified to be spliced by welding, the
39 epoxy coating shall be left off or removed from the surfaces to be heated, but in no
40 cases less than six inches of each bar being welded. After the welding is complete,
41 the Contractor shall apply epoxy patching material to the uncoated portions of the bar
42 in accordance with Section 6-02.3(24)H.
43

44 **6-02.3(25) Prestressed Concrete Girders**

45 In the first paragraph, the last sentence is revised to read:

46
47 WSDOT certification will be granted at, and renewed during, the annual prestressed
48 plant review and approval process in accordance with WSDOT Materials Manual M 46-
49 01.04 Standard Practice QC 6.
50

1 **6-02.3(25)I Fabrication Tolerances**

2 In the first paragraph, item number 21 is revised to read:

3
4 21. Differential Camber Between Girders in a Span (measured in place at the job
5 site):
6

For deck bulb tee girders and PCPS members with grouted shear keys:	Cambers shall be equalized when the differences in cambers between adjacent girders exceeds $\pm \frac{1}{4}$ inch
For deck bulb tee girders and PCPS members without grouted shear keys:	Cambers shall be equalized when the differences in cambers between adjacent girders exceeds $\pm \frac{1}{2}$ inch
For all other prestressed concrete girders:	$\pm \frac{1}{8}$ inch per 10 feet of girder length

7
8 **6-02.3(25)O Deck Bulb Tee Girder Flange Connection**

9 This section, including title, is revised to read:

10
11 **Deck Bulb Tee Girder Flange and PCPS Member Connection**

12 The Contractor shall submit a method of equalizing deflections as a Type 1 Working
13 Drawing. Any temporary strands in the top flange shall be cut per Section 6-02.3(25)N
14 prior to equalizing girder deflections.
15

16 Deck bulb tee girders and PCPS members with grouted shear keys shall be
17 constructed in the following sequence:

- 18 1. Deflections shall be equalized per the Contractor's equalization plan.
- 19 2. Intermediate diaphragms shall be placed and weld ties shall be welded.
20 Welding ground shall be attached directly to the steel plates being welded
21 when welding the weld-ties.
22
- 23 3. The keyways shown in the Plans to receive grout shall be filled flush with the
24 surrounding surfaces using a grout conforming to Section 9-20.3(2).
25
- 26 4. Equalization equipment shall not be removed and other construction
27 equipment shall not be placed on the structure until intermediate diaphragms
28 have attained a minimum compressive strength of 2,500 psi and keyway grout
29 has achieved a minimum compressive strength of 4000 psi.
30
31

32
33 Deck bulb tee girders and PCPS members without grouted shear keys shall be
34 constructed in the following sequence:

- 35 1. Deflections shall be equalized per the Contractor's equalization plan.
36
- 37 2. Intermediate diaphragms shall be placed and weld ties shall be welded.
38 Welding ground shall be attached directly to the steel plates being welded
39 when welding the weld-ties.
40
41

- 1 3. Equalization equipment shall not be removed and other construction
2 equipment shall not be placed on the structure until intermediate diaphragms
3 have attained a minimum compressive strength of 2,500 psi.
4

5 **6-02.3(26)F Prestressing Reinforcement**

6 The last sentence in the fourth paragraph is revised to read:

7
8 If the prestressing reinforcement will not be stressed and grouted for more than 7
9 calendar days after it is placed in the ducts, the Contractor shall place an approved
10 corrosion inhibitor conforming to Federal Specification MIL-I-22110C in the ducts.
11

12 **6-02.3(28) Precast Concrete Panels**

13 In the first paragraph, the third sentence is revised to read:

14
15 WSDOT Certification will be granted at, and renewed during, the annual precast plant
16 review and approval process in accordance with WSDOT Materials Manual M 46-01.04
17 Standard Practice QC 7.
18

19 **6-02.4 Measurement**

20 The following three new paragraphs are inserted before the last paragraph:

21
22 Expansion joint system___seal - superstr. will be measured by the linear foot along its
23 completed line and slope.
24

25 Expansion joint modification will be measured by the linear foot of expansion joint
26 modified along its completed line and slope.
27

28 Prestressed concrete girder will be measured by the linear foot of girder specified in
29 the Proposal.
30

31 **6-02.5 Payment**

32 In the paragraph following the bid item "Commercial Concrete", per cubic yard the second
33 sentence is revised to read:

34
35 All costs in connection with concrete curing, producing concrete surface finish with
36 form liners, and furnishing and applying pigmented sealer to concrete surfaces as
37 specified, shall be included in the unit contract price per cubic yard for "Conc. Class
38 _____".
39

40 The following new paragraph is inserted after the bid item "Superstructure (name bridge)",
41 lump sum:

42
43 All costs in connection with constructing, finishing and removing the bridge deck test
44 slab as specified in Section 6-02.3(10)D1 shall be included in the lump sum Contract
45 price for "Superstructure____" or "Bridge Deck____" for one bridge in each project, as
46 applicable.
47

48 In the paragraph following the bid item "Epoxy-Coated St. Reinf. Bar ____", per pound, the
49 first sentence is revised to read:
50

1 Payment for reinforcing steel shall include the cost of drilling holes in concrete for, and
2 setting, steel reinforcing bar dowels with epoxy bonding agent, and furnishing,
3 fabricating, placing, and splicing the reinforcement.
4

5 The bid item "Cure Box", lump sum and paragraph following bid item are deleted.
6

7 The following three new bid items are inserted before the bid item "Bridge Approach Slab",
8 per square yard:
9

10 "Expansion Joint System _____ - Superstr.", per linear foot.
11

12 "Expansion Joint Modification - _____", per linear foot.
13

14 "Prestressed Conc. Girder _____", per linear foot.
15

16 **6-03.AP6**

17 **Section 6-03, Steel Structures**

18 **April 6, 2015**

19 **6-03.2 Materials**

20 The first sentence in the fifth paragraph is revised to read:
21

22 The Contractor shall submit Type 1 Working Drawings describing the methods for
23 visibly marking the material so that it can be traced.
24

25 **6-03.3 Construction Requirements**

26 This section is revised to read:
27

28 Structural steel fabricators of plate and box girders, floorbeams, truss members,
29 stringers, cross frames, diaphragms, and laterals shall be certified under the AISC
30 Certification Program for Steel Bridge Fabricators, Advanced Bridges Category. When
31 fracture critical members are specified in the contract, structural steel fabricators shall
32 also meet the supplemental requirements F, Bridges with Fracture-Critical Members,
33 under the AISC Certification Program for Steel Bridge Fabricators.
34

35 **6-03.3(7) Shop Plans**

36 This section is revised to read:
37

38 The Contractor shall submit all shop detail plans for fabricating the steel as Type 2
39 Working Drawings.
40

41 If these plans will be submitted directly from the fabricator, the Contractor shall so
42 notify the Engineer in writing.
43

44 No material shall be fabricated until: (1) the Working Drawing review is complete, and
45 (2) the Engineer has accepted the materials source.
46

47 Before physical completion of the project, the Contractor shall furnish the Engineer one
48 set of reproducible copies of the as-built shop plans. The reproducible copies shall be

1 clear, suitable for microfilming, and on permanent sheets that measure no smaller than
2 11 by 17-inches. Alternatively, the shop drawings may be provided in an electronic
3 format with the concurrence of the Engineer.
4

5 **6-03.3(7)A Erection Methods**

6 The first paragraph is revised to read:

7
8 Before beginning to erect any steel Structure, the Contractor shall submit Type 2E
9 Working Drawings consisting of the erection plan and procedure describing the
10 methods the Contractor intends to use.
11

12 The second paragraph (up until the colon) is revised to read:

13
14 The erection plan and procedure shall provide complete details of the erection process
15 including, at a minimum, the following:
16

17 The third paragraph (up until the colon) is revised to read:

18
19 As part of the erection plan Working Drawings, the Contractor may submit details of an
20 engineered and fabricated lifting bracket bolted to the girder top flanges providing the
21 following requirements are satisfied:
22

23 In the third paragraph, the second sentence of item number 4 is revised to read:

24
25 Certification documentation from a previous project may be submitted;
26

27 The last sentence of the fourth paragraph is deleted.

28
29 The last paragraph is deleted.
30

31 **6-03.3(10) Straightening Bent Material**

32 In the first paragraph, the last sentence is revised to read:

33
34 A limited amount of localized heat may be applied only if carefully planned and
35 supervised, and only in accordance with the heat-straightening procedure Working
36 Drawing submittal.
37

38 The third paragraph is revised to read:

39
40 After straightening, the Contractor shall inspect the member for fractures using a
41 method proposed by the Contractor and accepted by the Contracting Agency.
42

43 The last paragraph is revised to read:

44
45 The procedure for heat straightening of universal mill (UM) plates by the mill or the
46 fabricator shall be submitted as a Type 2 Working Drawing.
47

48 **6-03.3(14) Edge Finishing**

49 In the first paragraph, the last sentence is revised to read:
50

1 Corners along exposed edges shall be broken by light grinding or another method
2 acceptable to the Engineer to achieve an approximate 1/16-inch chamfer or rounding.

3
4 In the fifth paragraph, the last sentence is revised to read:

5
6 The fabricator shall prevent excessive hardening of flange edges through preheating,
7 post heating, or control of the burning process as recommended by the steel
8 manufacturer.

9
10 The sixth paragraph is revised to read:

11
12 Hardness testing shall consist of testing thermal-cut edges with a portable hardness
13 tester. The hardness tester, and its operating test procedures, shall be submitted as a
14 Type 1 Working Drawing. The hardness tester shall be convertible to Rockwell C scale
15 values.

16
17 In the last paragraph, the last sentence is revised to read:

18
19 If thermal-cutting operations conform to procedures established by the steel
20 manufacturer, and hardness testing results are consistently within acceptable limits,
21 the Engineer may authorize a reduction in the testing frequency.

22
23 **6-03.3(15) Planing of Bearing Surfaces**

24 This section is supplemented with the following new paragraph:

25
26 Where mill to bear is specified in the Plans, the bearing end of the stiffener shall be
27 flush and square with the flange and shall have at least 75 percent of this area in
28 contact with the flange.

29
30 **6-03.3(25) Welding and Repair Welding**

31 In the first paragraph, the first sentence is revised to read:

32
33 Welding and repair welding of all steel bridges shall comply with the AASHTO/AWS
34 D1.5M/D1.5, latest edition, Bridge Welding Code.

35
36 In the second paragraph, the last sentence is revised to read:

37
38 No welding, including tack and temporary welds shall be done in the shop or field
39 unless the location of the welds is shown on the shop drawings reviewed and accepted
40 by the Engineer.

41
42 In the third paragraph, the first sentence is revised to read:

43
44 Welding procedures shall accompany the shop drawing Working Drawing submittal.

45
46 In the fourth paragraph, the first sentence is revised to read:

47
48 Welding shall not begin until completion of the shop plan Working Drawing review as
49 required in Section 6-03.3(7).

50
51 In item number 1 of the ninth paragraph, "approves" is revised to read "concur".

1
2 **6-03.3(25)A3 Ultrasonic Inspection**

3 The following new paragraph is inserted before the last paragraph:
4

5 A minimum of 30 percent of complete penetration vertical welds on steel column
6 jackets thicker than 5/16-inch, within 1.50 column jacket diameter of the top and
7 bottom of each column, shall be inspected. If any rejectable flaws are found, 100
8 percent of the weld within the specified limits shall be inspected. The largest column
9 cross section diameter for tapered column jackets shall constitute one column jacket
10 diameter.
11

12 **6-03.3(25)A4 Magnetic Particle Inspection**

13 Items number 3 and 4 are revised to read:
14

- 15 3. Complete penetration groove welds on plates $\frac{5}{16}$ -inch or thinner (excluding steel
16 column jackets) shall be 100 percent tested by the magnetic particle method.
17 Testing shall apply to both sides of the weld, if backing plate is not used. The ends
18 of each complete penetration groove weld at plate edges shall be tested by the
19 magnetic particle method.
20
- 21 4. A minimum of 30 percent of complete penetration vertical welds on steel column
22 jackets $\frac{5}{16}$ -inch or thinner, within 1.50 column jacket diameters of the top and
23 bottom of each column, shall be magnetic particle inspected. The largest column
24 cross section diameter for tapered column jackets shall constitute one column
25 jacket diameter.
26

27 The last paragraph is supplemented with the following new sentence:
28

29 If any rejectable flaws are found in any test length of item 4 above, 100 percent of the
30 weld within the specified limits shall be inspected.
31

32 **6-03.3(27) High Strength Bolt Holes**

33 The last paragraph is revised to read:
34

35 The Contractor shall submit Type 2 Working Drawings consisting of a detailed outline
36 of the procedures proposed to accomplish the work from initial drilling through shop
37 assembly.
38

39 **6-03.3(27)C Numerically Controlled Drilled Connections**

40 In the second paragraph, the first sentence is revised to read:
41

42 The Contractor shall submit Type 1 Working Drawings consisting of a detailed outline
43 of proposed N/C procedures.
44

45 **6-03.3(29) Welded Shear Connectors**

46 This section's content is deleted and replaced with the following:
47

48 Installation, production control, and inspection of welded shear connectors shall
49 conform to Chapter 7 of the AASHTO/AWS D1.5M/D1.5:2010 Bridge Welding Code. If
50 welded shear connectors are installed in the shop, installation shall be completed prior

1 to applying the shop primer coat in accordance with Section 6-07.3(9)G. If welded
2 shear connectors are installed in the field, the steel surface to be welded shall be
3 prepared to SSPC-SP 11, power tool cleaning, just prior to welding.
4

5 **6-03.3(33) Bolted Connections**

6 In the second paragraph, the first sentence is revised to read:

7
8 The Contractor shall submit Type 1 Working Drawings providing documentation of the
9 bolt tension calibrator, including brand, capacity, model, date of last calibration, and
10 manufacturer's instructions for use.

11
12 In the second sentence of the second paragraph, the word "approved" is deleted.

13
14 In item number 3 of the fifth paragraph, "approved" is revised to read "specified".

15
16 In the center column header of table 1, "AASHTO M 164" is revised to read "ASTM A 325".

17
18 In the column headings of table 3, "M 164" is revised to read "A 325".

19
20 In the tenth paragraph, item number 3, "approved" is revised to read "accepted" in the
21 second and third sentences of the first paragraph.

22
23 In the tenth paragraph, item number 3, the third paragraph is revised to read:

24
25 The Contractor shall submit Type 1 Working Drawings of the tension control bolt
26 assembly, including bolt capacities, type of bolt, nut, and washer lubricant, method of
27 packaging and protection of the lubricated bolt, installation equipment, calibration
28 equipment, and installation procedures.

29
30 In the first sentence of the last paragraph, "AASHTO M 164" is revised to read "ASTM A
31 325".

32
33 The second sentence of the last paragraph is revised to read:

34
35 Black ASTM A 325 bolts may be reused once if accepted by the Engineer.

36 In the last paragraph, the fourth sentence is revised to read:

37
38 Bolts to be reused shall be relubricated in accordance with the manufacturer's
39 recommendations.
40

41 **6-03.3(33)A Pre-Erection Testing**

42 In the fifth sentence of the first paragraph, "approved" is revised to read "accepted".

43
44 The third paragraph is revised to read:

45
46 The Contractor shall submit Type 1 Working Drawings consisting of the manufacturer's
47 detailed procedure for pre-erection (rotational capacity) testing of tension control bolt
48 assemblies.
49

1 **6-03.3(33)B Bolting Inspection**

2 In the last sentence of the first paragraph, "approved" is revised to read "specified".

3
4 The last paragraph is revised to read:

5
6 The Contractor shall submit Type 1 Working Drawings consisting of the manufacturer's
7 detailed procedure for routine observation to ensure proper use of the tension control
8 bolt assemblies.

9
10 **6-03.3(42) Surface Condition**

11 The first subparagraph is revised to read:

12
13 Painted steel surfaces shall be cleaned by methods required for the type of staining.
14 The Contractor shall submit a Type 1 Working Drawing of the cleaning method.

15
16 **6-04.AP6**

17 **Section 6-04, Timber Structures**

18 **January 5, 2015**

19 **6-04.3(3) Shop Details**

20 This section is revised to read:

21
22 The Contractor shall submit Type 2 Working Drawings consisting of shop detail plans
23 for all treated timber. These plans shall show dimensions for all cut, framed, or bored
24 timbers.

25
26 **6-05.AP6**

27 **Section 6-05, Piling**

28 **January 5, 2015**

29 **6-05.3(2) Ordering Piling**

30 The last paragraph is deleted.

31
32 **6-05.3(3)A Casting and Stressing**

33 In the second sentence of the first paragraph, "poured" is revised to read "cast".

34
35 **6-05.3(4) Manufacture of Steel Casings for Cast-In-Place Concrete Piles**

36 This section is revised to read:

37
38 The diameter of steel casings shall be as specified in the Contract. A full-penetration
39 groove weld between welded edges is required.

40
41 **6-05.3(5) Manufacture of Steel Piles**

42 This section is revised to read:

43
44 Steel piles shall be made of rolled steel H-pile sections, steel pipe piles, or of other
45 structural steel sections described in the Contract. A full-penetration groove weld
46 between welded edges is required.

1
2 **6-05.3(6) Splicing Steel Casings and Steel Piles**

3 This section is revised to read:

4
5 The Engineer will normally permit steel piles and steel casings for cast-in-place
6 concrete piles to be spliced. But in each case, the Contractor shall submit Type 2
7 Working Drawings supporting the need and describing the method for splicing. Welded
8 splices shall be spaced at a minimum distance of 10 feet. Only welded splices will be
9 permitted.

10
11 Splice welds for steel piles shall comply with Section 6-03.3(25) and AWS D1.1/D1.1M,
12 latest edition, Structural Welding Code. Splicing of steel piles shall be performed in
13 accordance with an approved weld procedure. The Contractor shall submit a Type 2
14 Working Drawing consisting of the weld procedure. For ASTM A 252 material, mill
15 certification for each lot of pipe to be welded shall accompany the submittal. The ends
16 of all steel pipe piling shall meet the fit-up requirements of AWS D1.1/D1.1M, latest
17 edition, Structural Welding Code Section 5.22.3.1, "Girth Weld Alignment (Tubular),"
18 when the material is spliced utilizing a girth weld.

19
20 Splice welds of steel casings for cast-in-place concrete piles shall be the Contractor's
21 responsibility and shall be welded in accordance with AWS D1.1/D1.1M, latest edition,
22 Structural Welding Code. A weld procedure submittal is not required for steel casings
23 used for cast-in-place concrete piles. Casings that collapse or are not watertight, shall
24 be replaced at the Contractor's expense.

25
26 **6-05.3(7)B Precast Concrete Piles**

27 The second to last sentence of the second paragraph is revised to read:

28
29 The Contractor shall submit Type 2 Working Drawings consisting of the method of
30 lifting the piles.

31
32 **6-05.3(8) Pile Tips and Shoes**

33 In the last paragraph, the second and third sentences are deleted and replaced with the
34 following new sentence:

35
36 If pile tips or shoes other than those denoted in the Qualified Products List are
37 proposed, the Contractor shall submit Type 2 Working Drawings consisting of shop
38 drawings of the proposed pile tip along with design calculations, specifications,
39 material chemistry and installation requirements, along with evidence of a pile driving
40 test demonstrating suitability of the proposed pile tip.

41
42 **6-05.3(9)A Pile Driving Equipment Approval**

43 In the first paragraph, the first sentence is revised to read:

44
45 Prior to driving any piles, the Contractor shall submit Type 2 Working Drawings
46 consisting of details of each proposed pile driving system.

47
48 In the second paragraph, the first sentence is revised to read:

1 The Contractor shall submit Type 2E Working Drawings consisting of a wave equation
2 analysis for all pile driving systems used to drive piling with required ultimate bearing
3 capacities of greater than 300 tons.
4

5 In the second paragraph, the second sentence is deleted.
6

7 The last paragraph is revised to read:
8

9 Changes to the pile driving system after completion of the Working Drawing review
10 require a revised Working Drawing submittal.
11

12 **6-05.3(9)B Pile Driving Equipment Minimum Requirements**

13 In the first paragraph, the first sentence is revised to read:
14

15 For each drop hammer used, the Contractor shall weigh it in the Engineer's presence
16 or submit a Type 1 Working Drawing consisting of a certificate of its weight.
17

18 In the third paragraph, the first sentence is revised to read:
19

20 For each diesel, hydraulic, steam, or air-driven hammer used, the Contractor shall
21 submit a Type 1 Working Drawing consisting of the manufacturer's specifications and
22 catalog.
23

24 In the fourth paragraph, "approval" is revised to read "permission".
25

26 The ninth paragraph is revised to read:
27

28 These requirements for minimum hammer size may be waived if a Type 2E Working
29 Drawing is submitted consisting of a wave equation analysis demonstrating the ability
30 of the hammer to obtain the required bearing capacity and minimum tip elevation
31 without damage to the pile.
32

33 **6-05.3(9)C Pile Driving Leads**

34 In the third paragraph, "approved" is revised to read "permitted".
35

36 **6-05.3(11)F Pile Damage**

37 In the first sentence of the second paragraph, "approved" is revised to read "accepted".
38

39 **6-05.3(11)G Pile Cutoff**

40 In the first paragraph, "Engineer's approval" is revised to read "Engineer's permission".
41

42 **6-05.3(11)H Pile Driving From or Near Adjacent Structures**

43 In the first paragraph, item number 3 is revised to read:
44

- 45 3. Type 2E Working Drawings are submitted in accordance with Sections 1-05.3 and
46 6-02.3(16), showing the structural adequacy of the existing Structure to safely
47 support all of the construction loads.
48

1 **6-05.3(12) Determination of Bearing Values**

2 In the footnote below the formula, "approved by the Engineer" is revised to read "acceptable
3 to the Engineer".
4

5 **6-05.3(13) Treatment of Timber Pile Heads**

6 In the second paragraph, the first sentence is revised to read:
7

8 After cutting treated timber piles to correct elevation, the Contractor shall brush three
9 coats of a preservative that meets the requirements of Section 9-09 on all pile heads
10 (except those to be covered with concrete footings or concrete caps).
11

12 **6-05.3(15) Completion of Cast-In-Place Concrete Piles**

13 In the first paragraph, "approval" is revised to read "acceptance".
14

15 **6-06.AP6**

16 **Section 6-06, Bridge Railings**

17 **January 5, 2015**

18 **6-06.3(2) Metal Railings**

19 The second paragraph is revised to read:
20

21 Before fabricating the railing, the Contractor shall submit Type 2 Working Drawings
22 consisting of the shop plans. The Contractor may substitute other rail connection
23 details for those shown in the Plans if details of these changes show in the shop plans
24 and if the Engineer accepts them in the Working Drawing response comments. In
25 reviewing the shop plan Working Drawings, the Engineer indicates only that they are
26 adequate and complete enough. The review does not indicate a check on dimensions.
27

28 **6-07.AP6**

29 **Section 6-07, Painting**

30 **January 5, 2015**

31 **6-07.3 Painting**

32 This section is supplemented with the following new subsections:
33

34 **6-07.3(14) Metallic Coatings**

35
36 **6-07.3(14)A General Requirements**

37 This specification covers the requirements for thermal spray metallic coatings, with
38 and without additional paint coats, as a means to prevent corrosion.
39

40 The coating system consists of surface preparation by wash cleaning and abrasive
41 blast cleaning, thermal spray application of a metallic coating using a material
42 made specifically for that purpose, and, when specified, shop primer coat or shop
43 primer coat plus top coat in accordance with Section 6-07.3(11)A. The system
44 also includes inspection and acceptance requirements.
45

1 **6-07.3(14)B Reference Standards**

2 SSPC-SP 10/NACE No. 2 Near White Blast Cleaning
3 SSPC CS 23.00 Guide for Thermal Spray Metallic Coating Systems
4 ASTM-C-633 Standard Test Method for Adhesion or Cohesion
5 Strength of Thermal Spray Coatings
6 ASTM D 4417 Standard Test Methods for Field Measurement of
7 Surface Profile of Blast-Cleaned Steel
8 ASTM D 6386 Standard Practice for Preparation of Zinc (Hot-Dip
9 Galvanized) Coated Iron and Steel Product and
10 Hardware Surfaces for Painting
11 ASTM D 4541 Standard Test Method for Pull-Off Strength of
12 Coatings Using Portable Adhesion Testers
13 ANSI/AWS C2.18 Guide for the Protection of Steel with Thermal
14 Sprayed Coatings of Aluminum, Zinc and their Alloys
15 and Composites

16
17 **6-07.3(14)C Quality Assurance**

18 A representative sample of each lot of the coating material used shall be
19 submitted to the Engineer for analysis prior to use. Zinc shall have a minimum
20 purity of 99.9 percent. Zinc Aluminum 85/15 wire shall be 14 percent minimum to
21 16 percent maximum aluminum.

22
23 The thermal sprayed coating shall have a uniform appearance. The coating shall
24 not contain any blisters, cracks, chips or loosely adhering particles, oil or other
25 surface contaminants, nodules, or pits exposing the substrate.

26
27 The thermal spray coating shall adhere to the substrate with a minimum bond of
28 700 psi. The Contractor's QA program shall include thermal spray coating bond
29 testing.

30
31 The Engineer may cut through the coating with a knife or chisel. If upon doing so,
32 any part of the coating lifts away from the base metal 1/4 in. or more ahead of the
33 cutting blade without cutting the metal, then the bond is considered not effective
34 and is rejected.

35
36 Coated areas which have been rejected or damaged in the inspection procedure
37 described shall have the defective sections blast cleaned to remove all of the
38 thermal sprayed coating and shall then be recoated. Before resubmittal and
39 inspection, those sections where coating has not reached the required thickness
40 shall be sprayed with additional metal until that thickness is achieved.

41
42 **6-07.3(14)D Submittals**

43 The Contractor shall submit to the Engineer, prior to abrasive blast cleaning, a 12
44 inch square steel plate, of the same material and approximate thickness of the
45 steel to be coated, blasted clean in accordance with Section 6-07.3(14)E. The
46 sample plate will be checked for specified angular surface pattern, the abrasive
47 grit size and type used, and the procedure used. This plate shall be used as the
48 visual standard to determine the acceptability of the cleaned surface. In the event
49 the Contractor's cleaning operation is inferior to the sample plate, the Contractor
50 shall be required to correct the cleaning operation to do a job comparable to the
51 specimen submitted.

1
2 At the same time as submitting the abrasive blast cleaned steel plate sample, the
3 Contractor shall submit to the Engineer, a second 12 inch square steel plate of the
4 same material and thickness, cleaned and thermal spray coated in accordance
5 with the same processes and with the same equipment as intended for use in
6 applying the thermal spray coatings. The Engineer may request additional
7 cleaned and thermal spray coated samples to be produced and submitted
8 coincident with thermal spray coating of the items specified in the Plans to receive
9 thermal spray coatings.

10
11 **6-07.3(14)E Surface Preparation**

12 Surface irregularities (e.g., sharp edges and/or carburized edges, cracks,
13 delaminations, pits, etc.) interfering with the application of the coating shall be
14 removed or repaired, prior to wash cleaning. Thermal cut edges shall be ground
15 to reduce hardness to attain the surface profile required from abrasive blast
16 cleaning.

17
18 All dirt, oil, scaling, etc. shall be removed prior to blast cleaning. All surfaces shall
19 be wash cleaned with either clean water at 8000 psi or water and detergent at
20 2000 psi with two rinses with clean water.

21
22 The surface shall be abrasive blast cleaned to near white metal (SSPC-SP 10).
23 The surface profile shall be measured using a surface profile comparator, replica
24 tape, or other method suitable for the abrasive being used in accordance with
25 ASTM D 4417.

26
27 Where zinc coatings up to and including 0.009 inch thick are to be applied, one of
28 the following abrasive grits shall be used with pressure blast equipment to produce
29 a 3.0 mils AA anchor tooth pattern:

- 30
31 1. Aluminum oxide or silicon carbide
32 mesh size: SAE G-25 to SAE G-40
33
34 2. Hardened steel grit
35 mesh size: SAE G-25 to SAE G-40
36
37 3. Garnet, flint, or crushed nickel or black beauty coal slag
38 mesh size: SAE G-25 to SAE G-50
39

40 Where zinc coatings greater than 0.010 inch thick are to be applied, one of the
41 following abrasive grits shall be used with pressure blast equipment to produce a
42 5.0 mils AA anchor tooth pattern:

- 43
44 1. Aluminum oxide or silicon carbide
45 mesh size: SAE G-18 to SAE G-25
46
47 2. Hardened steel grit
48 mesh size: SAE G-18 to SAE G-25
49
50 3. Garnet, flint, or crushed nickel or black beauty coal slag
51 mesh size: SAE G-18 to SAE G-25

1
2 The pressure of the blast nozzle, as measured with a needle probe gauge, with
3 pressure type blasting equipment shall be as follows:
4

- 5 1. With aluminum oxide, silicon carbide, flint, or slag - 50 psi minimum and
6 60 psi maximum.
7
8 2. With garnet or steel grit - 75 psi minimum.
9

10 The pressure at the blast nozzle, with siphon blasting (suction blasting), shall be
11 as follows:
12

- 13 1. With aluminum oxide, silicon carbide, flint, or slag - 75 psi maximum.
14
15 2. With garnet or steel grit - 90 psi maximum.
16

17 The abrasive blast stream shall be directed onto the substrate surface at a spray
18 angle of 75 to 90 degrees, and moved side to side. The nozzle to substrate
19 distance shall be 4 to 12 inches.
20

21 **6-07.3(14)F Application of Metallic Coating**

22 No surface shall be sprayed which shows any sign of condensed moisture or
23 which does not comply with Section 6-07.3(14)E. If rust bloom occurs within the
24 holding time between abrasive blast cleaning and thermal spraying, the surface
25 shall be reblasted at a blast angle as close to perpendicular to the surface as
26 possible to achieve a 2.0 to 4.0 mil anchor tooth pattern. Thermal spraying shall
27 not take place when the relative humidity is 90% or greater, when the steel
28 temperature is less than 5°F above the dew point, or when the air or steel
29 temperature is less than 40°F.
30

31 Clean, dry air shall be used with not less than 50 psi air pressure at the air
32 regulator. Not more than 50 feet of 3/8 in. ID hose shall be used between the air
33 regulator and the metallizing gun. The metallizing gun shall be started and
34 adjusted with the spray directed away from the work. During the spraying
35 operation and depending upon the equipment being used, the gun shall be held as
36 close to perpendicular as possible to the surface from 5 to 8 inches from the
37 surface of the work.
38

39 Manual spraying shall be done in a block pattern, typically 2 feet by 2 feet square.
40 The sprayed metal shall overlap on each pass to ensure uniform coverage. The
41 specified thickness of the coating shall be applied in multiple layers. In no case
42 are fewer than two passes of thermal spraying, overlapping at right angles,
43 acceptable.
44

45 At least one single layer of coating shall be applied within 4 hours of blasting and
46 the surface shall be completely coated to the specified thickness within 8 hours of
47 blasting.
48

49 The minimum coating thickness shall be 6 mils unless otherwise shown in the
50 Plans.
51

1 **6-07.3(14)G Applications of Shop Coats and Field Coats**

2 The surface shall be wiped clean with solvent immediately before applying the
3 wash primer. The wash primer shall have a low viscosity appropriate for
4 absorption into the thermal spray coating, and shall be applied within 8 hours after
5 completion of thermal spraying or before oxidation occurs. The dry film thickness
6 of the wash primer shall not exceed 0.5 mils or be less than 0.3 mils. It shall be
7 applied using an appropriate spray gun except in those areas where brush or roller
8 application is necessary. The subsequent shop primer or field coats shall be
9 applied no less than one-half hour after a wash primer.

10
11 The shop primer coat, when specified, shall be applied in accordance with Section
12 6-07.3(11)A and the paint manufacturer's recommendations.

13
14 All field coats, when specified, shall be applied in accordance with Section 6-
15 07.3(11)A and the paint manufacturer's recommendations. The color of the top
16 coat shall conform to Section 6-03.3(30) as supplemented in these Special
17 Provisions.

18
19 **6-07.3(2) Submittals**

20 The first paragraph is revised to read:

21
22 The Contractor shall submit Type 2 Working Drawings of the painting plan.

23
24 **6-07.3(10)A Containment**

25 The second paragraph is revised to read:

26
27 The containment length shall not exceed the length of a span (defined as pier to pier).
28 The containment system shall not cause any damage to the existing structure. All
29 clamps and other attachment devices shall be padded or designed such that they shall
30 not mark or otherwise damage the steel member to which they are attached. All
31 clamps and other attachment devices shall be fully described in the Contractor's
32 painting plan Working Drawing submittal. Field welding of attachments to the existing
33 structure will not be allowed. The Contractor shall not drill holes into the existing
34 structure or through existing structural members except as shown in the Contractor's
35 painting plan Working Drawing submittal. All provisions for dust collection, ventilation
36 and auxiliary lighting within the containment system shall be fully described the
37 Contractor's painting plan Working Drawing submittal.

38
39 In the second to last paragraph, "approved" is revised to read "accepted".

40
41 **6-07.3(10)E Surface Preparation – Full Paint Removal**

42 This section is revised to read:

43
44 For structures where full removal of existing paint is specified, the Contractor shall
45 remove any visible oil, grease, and road tar in accordance with SSPC-SP 1.

46
47 Following preparation by SSPC-SP 1, all steel surfaces to be painted shall be prepared
48 in accordance with SSPC-SP 10, near-white metal blast cleaning. Surfaces
49 inaccessible to near-white metal blast cleaning shall be prepared in accordance with
50 SSPC-SP 11, power tool cleaning to bare metal, as allowed by the Engineer.

1
2
3
4
5
6
7
8
9
10
11
12
13
14
15
16
17
18
19
20
21
22
23
24
25
26
27
28
29
30
31
32
33
34
35
36
37
38
39
40
41
42
43
44
45
46
47
48
49
50

6-07.3(10)F Collecting, Testing and Disposal of Containment Waste

In the first paragraph, the last sentence before the numbered list is revised (up until the colon) to read:

The sealed waste containers shall be stored in accordance with Section 1-06.4, the painting plan, and the following requirements:

In the second paragraph, the first sentence is revised to read:

All material collected by and removed from the containment system shall be taken to a landside staging area, provided by the Contractor, for further processing and storage prior to transporting for disposal.

The ninth paragraph is revised to read:

The Contractor shall submit a Type 1 Working Drawing of all TCLP results.

The first sentence of the last paragraph is revised to read:

The Contractor shall submit a Type 1 Working Drawing consisting of waste disposal documentation within 15 working days of each disposal.

6-07.3(10)K Coating Thickness

The last paragraph is revised to read:

If the specified number of coats does not produce a combined dry film thickness of at least the sum of the thicknesses required per coat, or if an individual coat does not meet the minimum thickness, or if visual inspection shows incomplete coverage, the coating system will be rejected, and the Contractor shall discontinue painting and surface preparation operations and shall submit a Type 2 Working Drawing of the repair proposal. The repair proposal shall include documentation demonstrating the cause of the less than minimum thickness along with physical test results, as necessary, and modifications to work methods to prevent similar results. The Contractor shall not resume painting or surface preparation operations until receiving the Engineer's acceptance of the completed repair.

6-07.3(10)L Environmental Condition Requirements Prior to Application of Paint

In the last paragraph, the second to last sentence is revised to read:

If a paint system manufacturer's recommendations allow for application of a paint under environmental conditions other than those specified, the Contractor shall submit a Type 2 Working Drawing consisting of a letter from the paint manufacturer specifying the environmental conditions under which the paint can be applied.

In the last sentence of the last paragraph, "approval" is revised to read "concurrence".

6-07.3(11)B1 Submittals

The first paragraph (up until the colon) is revised to read:

1
2 The Contractor shall submit Type 2 Working Drawings consisting of the following
3 information:
4

5 **6-07.3(11)B3 Galvanized Surface Cleaning and Preparation**

6 The first paragraph is revised to read:
7

8 Galvanized surfaces receiving the powder coating shall be cleaned and prepared for
9 coating in accordance with ASTM D 6386, and the project-specific powder coating
10 plan.
11

12 **6-07.3(11)B4 Powder Coating Application and Curing**

13 The first paragraph (up until the colon) is revised to read:
14

15 After surface preparation, the two-component powder coating shall be applied in
16 accordance with the powder coating manufacturer's recommendations, the project-
17 specific powder coating plan, and as follows:
18

19 **6-07.3(11)B5 Testing**

20 In the fifth sentence of the first paragraph, the phrase "as approved by the Engineer" is
21 deleted.
22

23 The second paragraph is revised to read:
24

25 The results of the QC testing shall be documented in a QC report, and submitted as a
26 Type 2 Working Drawing.
27

28 In the fourth paragraph, the phrase "as approved by the Engineer" is deleted.
29

30 In the last paragraph, "Engineer's approval" is revised to read "Engineer's acceptance".
31

32 **6-07.3(11)B6 Coating Protection for Shipping**

33 The phrase "as approved by the Engineer" is deleted from this section.
34

35 The first sentence of the last paragraph is revised to read:
36

37 After erection, all coating damage due to the Contractor's shipping, storage, handling,
38 and erection operations shall be repaired by the Contractor in accordance with the
39 project-specific powder coating plan.
40

41 **6-07.5 Payment**

42 The following new paragraph is inserted before the last paragraph:
43

44 All costs in connection with producing the metallic coatings as specified shall be
45 included in the unit contract price for the applicable item or items of work.
46

1 **6-09.AP6**

2 **Section 6-09, Modified Concrete Overlays**
3 **January 5, 2015**

4 **6-09.2 Materials**

5 The second sentence of the fifth paragraph is revised to read:

6

7 Microsilica will be accepted based on submittal of a Manufacturer's Certificate of
8 Compliance.

9

10 The seventh paragraph is revised to read:

11

12 Latex admixture will be accepted based on submittal of a Manufacturer's Certificate of
13 Compliance.

14

15 **6-09.3(1)H Mobile Mixer for Latex Modified Concrete**

16 In item number 2 of the first paragraph, "An approved recording meter" is revised to read "A
17 recording meter".

18

19 In item number 3 of the first paragraph, "an approved flow meter" is revised to read "a flow
20 meter".

21

22 **6-09.3(1)J Finishing Machine**

23 The last two sentences of the last paragraph are revised to read:

24

25 A machine with a vibrating pan as an integral part may be proposed. Other finishing
26 machines will be allowed subject to concurrence of the Engineer.

27

28 **6-09.3(2) Submittals**

29 This section is revised to read:

30

31 The Contractor shall submit the following Working Drawings in accordance with
32 Section 1-05.3:

33

34 1. A Type 1 Working Drawing of the type of machine (rotary milling, hydro-
35 demolition, or shot blasting) selected by the Contractor for use in this project to
36 scarify concrete surfaces.

37

38 2. A Type 1 Working Drawing of the axle loads and axle spacing of the rotary
39 milling machine (if used).

40

41 3. A Type 2 Working Drawing of the Runoff Water Disposal Plan (if a hydro-
42 demolition machine is used). The Runoff Water Disposal Plan shall describe
43 all provisions for the containment, collection, filtering, and disposal of all runoff
44 water and associated contaminants generated by the hydro-demolition
45 process, including containment, collection and disposal of runoff water and
46 debris escaping through breaks in the bridge deck.

47

- 1 4. A Type 2 Working Drawing of the method and materials used to contain,
2 collect, and dispose of all concrete debris generated by the scarifying process,
3 including provisions for protecting adjacent traffic from flying debris.
4
- 5 5. A Type 1 Working Drawing of the mix design for concrete Class M, and either
6 fly ash modified concrete, microsilica modified concrete, or latex modified
7 concrete, as selected by the Contractor for use in this project in accordance
8 with Section 6-09.3(3).
9
- 10 6. A Type 1 Working Drawing of samples of the latex admixture and the portland
11 cement for testing and compatibility (if latex modified concrete is used).
12
- 13 7. A Type 2 Working Drawing of the paving equipment specifications and details
14 of the screed rail support system, including details of anchoring the rails and
15 providing rail continuity.
16

17 **6-09.3(3)A General**

18 In the last paragraph, the phrase "and as approved by the Engineer" is deleted.
19

20 **6-09.3(4)B Latex Admixture**

21 In the second sentence of the second paragraph, the phrase "and as approved by the
22 Engineer" is deleted.
23

24 **6-09.3(5)A General**

25 The second paragraph is deleted.
26

27 In the third and fourth paragraphs, the phrase "and as approved by the Engineer" is
28 deleted.
29

30 In the fifth paragraph, "approved by the Engineer" is revised to read "acceptable to the
31 Engineer".
32

33 **6-09.3(5)B Testing of Hydro-Demolition and Shot Blasting Machines**

34 In the last sentence of the last paragraph, "approval" is revised to read "acceptance".
35

36 **6-09.3(5)C Hydro-Demolishing**

37 In the third and fourth paragraphs, the phrase "as approved by the Engineer" is deleted.
38

39 **6-09.3(6)B Deck Repair Preparation**

40 The second to last paragraph is revised to read the following three new paragraphs:
41

42 The exposed steel reinforcing bars and concrete in the repair area shall be
43 sandblasted or hydro-blasted and blown clean just prior to placing concrete.
44

45 Where existing steel reinforcing bars inside deck repair areas show deterioration
46 exceeding the limits defined in the Plans, the Contractor shall furnish and place steel
47 reinforcing bars alongside the deteriorated bars in accordance with the details shown
48 in the Plans. Payment for such extra Work will be by force account as provided in
49 Section 1-09.6.
50

1 Bridge deck areas outside the repair area or steel reinforcing bar inside or outside the
2 repair area damaged by the Contractor's operations, shall be repaired by the
3 Contractor at no additional expense to the Contracting Agency, and to the satisfaction
4 of the Engineer.
5

6 **6-09.3(6)C Placing Deck Repair Concrete**

7 The third paragraph is supplemented with the following:
8

9 The Work of Type 1 further deck preparation shall consist of removing and disposing of
10 the concrete within the repair area.
11

12 The following new sentence is inserted before the last sentence of the last paragraph:
13

14 The Work of Type 2 further deck preparation shall consist of removing and disposing of
15 concrete within the repair area, and furnishing, placing, finishing, and curing the repair
16 concrete.
17

18 **6-09.3(7) Surface Preparation for Concrete Overlay**

19 The first sentence of the second paragraph is revised to read:
20

21 If either a rotary milling machine or a shot blasting machine is used for concrete
22 scarification, then the concrete deck shall be sandblasted or shot blasted, using
23 equipment identified in the Working Drawing submittals, until sound concrete is
24 exposed.
25

26 The third paragraph is revised to read:
27

28 If a hydro-demolition machine is used for concrete scarification, then the concrete deck
29 shall be cleaned by water blasting with 7,000 psi minimum pressure, until sound
30 concrete is exposed.
31

32 In the fourth paragraph, "as approved by the Engineer" is revised to read "accepted by the
33 Engineer".
34

35 In the last sentence of the eighth paragraph, the phrase "as approved by the Engineer" is
36 deleted.
37

38 In the first sentence of the last paragraph, "approved" is revised to read "allowed".
39

40 **6-09.3(8)B Quality Assurance for Latex Modified Concrete Overlays**

41 The second sentence of the last paragraph is revised to read:
42

43 The technical representative shall be capable of performing, demonstrating, inspecting,
44 and testing all of the functions required for placement of the latex modified concrete as
45 specified in Section 6-09.3(11).
46

47 The fourth sentence of the last paragraph is revised to read:
48

49 Recommendations made by the technical representative on or off the jobsite shall be
50 adhered to by the Contractor at no additional expense to the Contracting Agency.

1
2 **6-09.3(10)A Survey of Existing Bridge Deck Prior to Scarification**

3 The third sentence of the fourth paragraph is revised to read:

4
5 A Type 1 Working Drawing of each day's survey record shall be provided to the
6 Engineer within three working days after the end of the shift.
7

8 **6-09.3(10)B Establishing Finish Overlay Profile**

9 In the fourth sentence of the first paragraph, "approved by the Engineer" is revised to read
10 "specified by the Engineer".
11

12 In the second paragraph, the phrase "and as approved by the Engineer" is deleted.
13

14 **6-09.3(11) Placing Concrete Overlay**

15 In the fourth paragraph, the last sentence of item number 3 is revised to read:

16
17 If the Contractor elects to work at night to meet these criteria, adequate lighting shall
18 be provided at no additional expense to the Contracting Agency.
19

20 **6-09.4 Measurement**

21 The last paragraph is deleted and replaced with the following:

22
23 Further deck preparation for Type 1 deck repair and for Type 2 deck repair will be
24 measured by the square foot of surface area of deck concrete removed in accordance
25 with Section 6-09.3(6).
26

27 **6-09.5 Payment**

28 The Bid item "Further Deck Preparation", per cubic foot and the paragraph following this Bid
29 item are deleted and replaced with the following two new Bid items:
30

31 "Further Deck Preparation for Type 1 Deck Repair", per square foot.

32
33 "Further Deck Preparation for Type 2 Deck Repair", per square foot.
34

35 The Bid item "Further Deck Preparation", force account and the paragraph following this Bid
36 item are deleted.
37

38 **6-10.AP6**

39 **Section 6-10, Concrete Barrier**
40 **January 5, 2015**

41 **6-10.1 Description**

42 In the second paragraph, "approved" is revised to read "specified".
43

44 **6-10.3 Construction Requirements**

45 In the first paragraph, "approved" is revised to read "specified".
46

47 **6-10.3(5) Temporary Concrete Barrier**

48 The last sentence of the first paragraph is deleted.

1
2 The second paragraph is revised to read:

3
4 If the Contract calls for the removal and resetting of permanent barrier, and the
5 permanent barrier is not required to remain in place until reset, the permanent barrier
6 may be substituted for temporary concrete barrier. Any of the permanent barrier
7 damaged during its use as temporary barrier will become the property of the Contractor
8 and be replaced with permanent barrier when the permanent barrier is reset to its
9 permanent location.

10
11 The third paragraph is revised to read:

12
13 All barrier shall be in good condition, without cracks, chips, spalls, dirt, or traffic marks.
14 If any barrier segment is damaged during or after placement, the Contractor shall
15 immediately repair it to the Engineer's satisfaction or replace it with an undamaged
16 section.

17
18 The following new paragraph is inserted after the third paragraph:

19
20 Delineators shall be placed on the traffic face of the barrier 6 inches from the top and
21 spaced a maximum of 40 feet on tangents and 20 feet through curves. The reflector
22 color shall be white on the right side of traffic and yellow on the left side of traffic. The
23 Contractor shall maintain, replace and clean the delineators when ordered by the
24 Engineer.

25
26 **6-11.AP6**

27 **Section 6-11, Reinforced Concrete Walls**
28 **January 5, 2015**

29 **6-11.3(1) Submittals**

30 The first paragraph is revised to read:

31
32 The Contractor shall submit Type 2E Working Drawings consisting of excavation
33 shoring plans in accordance with Section 2-09.3(3)D.

34
35 The second paragraph is revised to read:

36
37 The Contractor shall submit Type 2E Working Drawings of falsework and formwork
38 plans in accordance with Sections 6-02.3(16) and 6-02.3(17).

39
40 The third paragraph (up until the colon) is revised to read:

41
42 If the Contractor elects to fabricate and erect precast concrete wall stem panels, Type
43 2E Working Drawings of the following information shall be submitted in accordance
44 with Section 6-02.3(28)A:

45
46 The last paragraph is deleted.

1 **6-11.3(3) Precast Concrete Wall Stem Panels**
2 In the third paragraph, the phrase "as approved by the Engineer" is deleted.

3
4 **6-12.AP6**

5 **Section 6-12, Noise Barrier Walls**
6 **January 5, 2015**

7 **6-12.3(1) Submittals**

8 In the first paragraph, the second sentence is revised to read:

9
10 The Contractor shall submit a Type 2 Working Drawing consisting of the noise barrier
11 wall access plan.

12
13 The second paragraph (up until the colon) is revised to read:

14
15 For construction of all noise barrier walls with shafts, the Contractor shall submit a
16 Type 2 Working Drawing consisting of the shaft construction plan, including at a
17 minimum the following information:

18
19 In the third paragraph, the first sentence is revised to read:

20
21 For construction of precast concrete noise barrier walls, the Contractor shall submit
22 Type 2 Working Drawings consisting of shop drawings for the precast concrete panels
23 in accordance with Section 6-02.3(28)A.

24
25 **6-12.3(2) Work Access and Site Preparation**

26 In the first paragraph, the first sentence is revised to read:

27
28 The Contractor shall construct work access in accordance with the work access plan.

29
30 **6-12.3(3) Shaft Construction**

31 The first paragraph is revised to read:

32
33 The Contractor shall excavate and construct the shafts in accordance with the shaft
34 construction plan.

35
36 In the last sentence of the third paragraph, "approved by the Engineer" is revised to read
37 "acceptable to the Engineer".

38
39 The fourth paragraph is revised to read:

40
41 When caving conditions are encountered, the Contractor shall stop further excavation
42 until implementing the method to prevent ground caving as specified in the shaft
43 construction plan.

44
45 In the last sentence of the fifth paragraph, "approved" is revised to read "accepted".

46
47 In the seventh paragraph, "approval" is revised to read "acceptance".

48

1 In the eighth paragraph, the third sentence is revised to read:

2
3 The Contractor shall install the steel reinforcing bar cage as specified in the shaft
4 construction plan.

5
6 In the second sentence of the last paragraph, "approval" is revised to read "acceptance".

7
8 In the fourth sentence of the last paragraph, the word "approved" is deleted.

9
10 **6-12.3(6) Precast Concrete Panel Fabrication and Erection**

11 In item number 3, the second paragraph is revised to read:

12
13 After receiving the Engineer's review of the shop drawings, the Contractor shall cast
14 one precast concrete panel to be used as the sample panel. The Contractor shall
15 construct the sample panel in accordance with the procedure and details specified in
16 the shop drawings. The Contractor shall make the sample panel available to the
17 Engineer for acceptance.

18
19 In item number 3, the first sentence of the third paragraph is revised to read:

20
21 Upon receiving the Engineer's acceptance of the sample panel, the Contractor shall
22 continue production of precast concrete panels for the noise barrier wall.

23
24 In item number 3, the third sentence of the third paragraph is revised to read:

25
26 The sample panel shall be retained at the fabrication site until all precast concrete
27 panels have been fabricated and accepted.

28
29 **6-12.3(10) Finish Line Ground Dressing**

30 In the last sentence of the second paragraph, the phrase "as approved by the Engineer" is
31 deleted.

32
33 **6-13.AP6**

34 **Section 6-13, Structural Earth Walls**

35 **January 5, 2015**

36 **6-13.3(1) Quality Assurance**

37 In the first paragraph, the first sentence is revised to read:

38
39 The structural earth wall manufacturer shall provide a qualified and experienced
40 representative to resolve wall construction problems.

41
42 In the first paragraph, the last sentence is revised to read:

43
44 Recommendations made by the structural earth wall manufacturer's representative
45 shall be followed by the Contractor.

46
47 In the second paragraph, item number 4 is revised to read:

- 1 4. The base of the structural earth wall excavation shall be within three inches of the
2 staked elevations, unless otherwise accepted or specified by the Engineer.
3

4 In the second paragraph, item number 6 is revised to read:

- 5
6 6. The backfill reinforcement layers shall be located horizontally and vertically within
7 one inch of the locations shown in the structural earth wall working drawings.
8

9 **6-13.3(2) Submittals**

10 In the first paragraph, the first sentence is revised to read:

11
12 The Contractor, or the supplier as the Contractor's agent, shall furnish a
13 Manufacturer's Certificate of Compliance certifying that the structural earth wall
14 materials conform to the specified material requirements.
15

16 The second paragraph is revised to read:

17
18 A Type 1 Working Drawing of all test results, performed by the Contractor or the
19 Contractor's supplier, which are necessary to assure compliance with the
20 specifications, shall be submitted along with each Manufacturer's Certificate of
21 Compliance.
22

23 In the third paragraph, the first sentence is revised to read:

24
25 Before fabrication, the Contractor shall submit a Type 1 Working Drawing consisting of
26 the field construction manual for the structural earth walls, prepared by the wall
27 manufacturer.
28

29 In the fourth paragraph, the first sentence is revised to read:

30
31 The Contractor, through the license/patent holder for the structural earth wall system,
32 shall submit Type 2E Working Drawings consisting of detailed design calculations and
33 details.
34

35 The last paragraph is deleted.
36

37 **6-13.3(3) Excavation and Foundation Preparation**

38 In the first paragraph, the last two sentences are revised to read:

39
40 The foundation for the structure shall be graded level for a width equal to or exceeding
41 the length of reinforcing as shown in the structural earth wall working drawings and, for
42 walls with geogrid reinforcing, in accordance with Section 2-12.3. Prior to wall
43 construction, the foundation, if not in rock, shall be compacted as accepted by the
44 Engineer.
45

46 **6-13.3(6) Welded Wire Faced Structural Earth Wall Erection**

47 The first two sentences are revised to read:

48
49 The Contractor shall erect the welded wire wall reinforcement in accordance with the
50 wall manufacturer's field construction manual. Construction geotextile for wall facing

1 shall be placed between the backfill material within the reinforced zone and the coarse
2 granular material immediately behind the welded wire wall facing, as shown in the
3 Plans and the structural earth wall working drawings.

4
5 **6-13.3(7) Backfill**

6 The third paragraph is revised to read:

7
8 Misalignment or distortion of the precast concrete facing panels or concrete blocks due
9 to placement of backfill outside the limits of this specification shall be corrected in a
10 manner acceptable to the Engineer.

11
12 In item number 4 of the fifth paragraph, the phrase "as approved by the Engineer" is
13 deleted.

14
15 The last paragraph is deleted.

16
17 **6-13.3(8) Guardrail Placement**

18 In the first sentence of the second paragraph, "approval" is revised to read "permission".

19
20 **6-13.3(9) SEW Traffic Barrier and SEW Pedestrian Barrier**

21 The first paragraph (up until the colon) is revised to read:

22
23 The Contractor, in conjunction with the structural earth wall manufacturer, shall design
24 and detail the SEW traffic barrier and SEW pedestrian barrier in accordance with
25 Section 6-12.3(2) and the above ground geometry details shown in the Plans. The
26 barrier Working Drawings and supporting calculations shall be Type 2E and shall
27 include, at a minimum, the following:

28
29 **6-14.AP6**

30 **Section 6-14, Geosynthetic Retaining Walls**
31 **January 5, 2015**

32 **6-14.2 Materials**

33 In the first paragraph, the section number next to "Anchor rods and associated nuts,
34 washers and couplers" is revised to read:

35
36 9-06.5(4)

37
38 The following new paragraph is inserted after the first paragraph:

39
40 Anchor plate shall conform to ASTM A 36, ASTM A 572 Grade 50, or ASTM A 588.

41
42 **6-14.3(2) Submittals**

43 The first paragraph (up until the colon) is revised to read:

44
45 The Contractor shall submit Type 2 Working Drawings consisting of detailed plans for
46 each wall. As a minimum, the submittals shall include the following:

1 **6-14.3(4) Erection and Backfill**

2 In the second sentence of the second paragraph, "approved by" is revised to read
3 "acceptable to".

4
5 In the last sentence of the fifth paragraph, "approval" is revised to read "permission".

6
7 The sixth paragraph is deleted.

8
9 In item number 5 in the eighth paragraph, the phrase "as approved by the Engineer" is
10 deleted.

11
12 In the ninth paragraph, the first sentence is revised to read:

13
14 The Contractor shall construct wall corners at the locations shown in the Plans, and in
15 accordance with the wall corner construction sequence and method in the Working
16 Drawing submittal.

17
18 In the last paragraph, the first sentence is revised to read:

19
20 Where required by retaining wall profile grade, the Contractor shall terminate top layers
21 of retaining wall geosynthetic and backfill in accordance with the method in the
22 Working Drawing submittal.

23
24 **6-14.5 Payment**

25 In the paragraph following the Bid item "Concrete Fascia Panel", per square foot, "concrete
26 leveling pad" is revised to read "concrete footing".

27
28 **6-15.AP6**

29 **Section 6-15, Soil Nail Walls**
30 **January 15, 2015**

31 **6-15.3(3) Submittals**

32 The first paragraph (excluding the numbered list) is revised to read:

33
34 The Contractor shall submit Type 2 Working Drawings of the following information:
35

36 **6-15.3(6) Soil Nailing**

37 In the first paragraph, the last sentence is revised to read:

38
39 Damaged or defective encapsulation shall be repaired in accordance with the
40 manufacturer's recommendations.

41
42 The eighth paragraph is revised to read:

43
44 If sections of the wall are constructed at different times than the adjacent soil nail
45 sections, the Contractor shall use stabilizing berms, temporary slopes, or other
46 measures acceptable to the Engineer, to prevent sloughing or failure of the adjacent
47 soil nail sections.
48

1 **6-15.3(8) Soil Nail Testing and Acceptance**

2 In the first paragraph, the second sentence is revised to read:

3
4 The Contractor shall submit Type 1 Working Drawings of all test data.

5
6 The last sentence of the seventh paragraph is revised to read:

7
8 The Contractor shall submit Type 2E Working Drawings of the reaction frame.

9
10 **6-15.3(8)A Verification Testing**

11 In the third paragraph, the first sentence is revised to read:

12
13 The Contractor shall submit Type 2E Working Drawings consisting of design details of
14 the verification testing, including the system for distributing test load pressures to the
15 excavation surface and appropriate nail bar size and reaction plate.

16
17 **6-16.AP6**

18 **Section 6-16, Soldier Pile and Soldier Pile Tieback Walls**
19 **January 5, 2015**

20 **6-16.3(2) Submittals**

21 The first paragraph is revised to read:

22
23 The Contractor shall submit Type 2 Working Drawings consisting of shop plans as
24 specified in Section 6-03.3(7) for all structural steel, including the steel soldier piles,
25 and shall submit Type 2 Working Drawings consisting of shop plans and other details
26 as specified in Section 6-17.3(3) for permanent ground anchors.

27
28 The second paragraph is revised to read:

29
30 The Contractor shall submit Type 1 Working Drawings consisting of the permanent
31 ground anchor grout mix design and the procedures for placing the grout.

32
33 The third paragraph (excluding the numbered list) is revised to read:

34
35 The Contractor shall submit Type 2E Working Drawings consisting of forming plans for
36 the concrete fascia panels, as specified in Sections 6-02.3(16) and 6-02.3(17).

37
38 In the fourth paragraph, the first sentence is revised to read:

39
40 The Contractor shall submit Type 2 Working Drawings consisting of a shaft installation
41 plan.

42
43 The last paragraph is deleted.

44
45 **6-16.3(3) Shaft Excavation**

46 In the third paragraph, the last sentence is revised to read:

1 A temporary casing, slurry, or other methods specified in the shaft installation plan
2 shall be used if necessary to ensure such safety and stability.

3
4 The fourth paragraph is revised to read:

5
6 Where caving in conditions are encountered, no further excavation will be allowed until
7 the Contractor has implemented the method to prevent ground caving as submitted in
8 accordance with item 4 of the Shaft Installation Plan.

9
10 The sixth paragraph is revised to read:

11
12 The excavated shaft shall be inspected and receive acceptance by the Engineer prior
13 to proceeding with construction.

14
15 **6-16.3(6)B Temporary Lagging**

16 The second paragraph (up until the colon) is revised to read:

17
18 The Contractor shall submit Type 2E Working Drawings consisting of the soldier pile
19 wall lagging design details and supporting design calculations. The submittal shall
20 include, at a minimum, the following:

21
22 In item number 4 of the second paragraph, "approved by" is revised to read "acceptable to".

23
24 The last paragraph (excluding the table) is revised to read:

25
26 Notwithstanding the requirements of Section 1-06.1, steel materials used by the
27 Contractor as temporary lagging may be salvaged steel provided that the use of such
28 salvaged steel materials shall be subject to visual inspection and acceptance by the
29 Engineer. For salvaged steel materials where the grade of steel cannot be positively
30 identified, the design stresses for the steel shall conform to the Section 6-02.3(17)B
31 requirements for salvaged steel, regardless of whether rivets are present or not.

32
33 **6-16.3(6)D Installing Lagging and Permanent Ground Anchor**

34 In the last sentence of the second paragraph, the phrase "as approved by the Engineer" is
35 deleted.

36
37 In the last sentence of the fourth paragraph, the phrase "as approved by the Engineer" is
38 deleted.

39
40 **6-16.3(8) Concrete Fascia Panel**

41 In the first paragraph, the phrase "as approved by the Engineer" is deleted.

42
43
44 **6-17.AP6**

45 **Section 6-17, Permanent Ground Anchors**
46 **January 5, 2015**

47 **6-17.3(3) Submittals**

48 The first paragraph is revised to read:

1
2 The Contractor shall submit Type 2 Working Drawings consisting of details and
3 structural design calculations for the ground anchor system or systems intended for
4 use.

5
6 The second paragraph is revised to read:

7
8 The Contractor shall submit a Type 1 Working Drawing consisting of a detailed
9 description of the construction procedure proposed for use.

10
11 The third paragraph (up until the colon) is revised to read:

12
13 The Contractor shall submit a Type 2 Working Drawing consisting of ground anchor
14 schedule giving:

15
16 In the fourth paragraph, the first sentence is revised to read:

17
18 The Contractor shall submit a Type 2 Working Drawing detailing the ground anchor
19 tendon and the corrosion protection system.

20
21 In the fourth paragraph, item number 3 is revised to read:

- 22
23 3. Unbonded length corrosion protection system, including the permanent rubber seal
24 between the trumpet and the tendon unbonded length corrosion protection and the
25 transition between the tendon bond length and the unbonded tendon length
26 corrosion protection.

27
28 The last five paragraphs are deleted and replaced with the following four new paragraphs:

29
30 The Contractor shall submit Type 2 Working Drawings consisting of shop plans as
31 specified in Section 6-03.3(7) for all structural steel, including the permanent ground
32 anchors.

33
34 The Contractor shall submit Type 1 Working Drawings consisting of the mix design for
35 the grout conforming to Section 9-20.3(4) and the procedures for placing the grout.
36 The Contractor shall also submit the methods and materials used in filling the annulus
37 over the unbonded length of the anchor.

38
39 The Contractor shall submit Type 2 Working Drawings consisting of the method
40 proposed to be followed for the permanent ground anchor testing. This shall include all
41 necessary drawings and details to clearly describe the method proposed.

42
43 The Contractor shall submit Type 2 Working Drawings consisting of calibration data for
44 each load cell, test jack, pressure gauge and master pressure gauge to be used. The
45 calibration tests shall have been performed by an independent testing laboratory and
46 tests shall have been performed within 60 calendar days of the date submitted.

47
48 **6-17.3(5) Tendon Fabrication**

49 In the tenth paragraph, the last sentence is deleted.

50
51 The twelfth paragraph is revised to read:

1
2 The total anchor length shall not be less than that indicated in the Plans or the Working
3 Drawing submittal.

4
5 In the last paragraph, the phrase "as approved by the Engineer" is deleted.

6
7 **6-17.3(7) Installing Permanent Ground Anchor**

8 In the second paragraph, the third sentence is revised to read:

9
10 The Contractor's method to prevent ground movement shall be submitted as a Type 2
11 Working Drawing.

12
13 In the second paragraph, the second to last sentence is revised to read:

14
15 At the point of entry the ground anchor shall be installed within plus or minus three
16 degrees of the inclination from horizontal shown in the Plans or the Working Drawing
17 submittal.

18
19 **6-18.AP6**

20 **Section 6-18, Shotcrete Facing**
21 **January 5, 2015**

22 **6-18.3(1) Submittals**

23 In the first paragraph, the first sentence (up until the colon) is revised to read:

24
25 The Contractor shall submit Type 2 Working Drawings consisting of the following:

26
27 In the first paragraph, item number 2 is revised to read:

- 28
29 2. Method and equipment used to apply, finish and cure the shotcrete facing.

30
31 The last paragraph is deleted.

32
33 **6-18.3(2) Mix Design**

34 In the first paragraph, the second and third sentences are deleted.

35
36 In the last sentence of the second paragraph, "and approved by the Engineer" is deleted.

37
38 **6-18.3(3)A Preproduction Testing**

39 In the last sentence, "approved" is revised to read "accepted".

40
41 **6-18.3(7) Shotcrete Application**

42 In the last paragraph, the first sentence is revised to read:

43
44 If field inspection or testing, by the Engineer, indicates that any shotcrete produced,
45 fails to meet the requirements, the Contractor shall immediately modify procedures,
46 equipment, or system, as necessary to produce specification material.
47

1 **6-19.AP6**

2 **Section 6-19, Shafts**

3 **April 6, 2015**

4 **6-19.3(2) Shaft Construction Submittal**

5 The last sentence is revised to read:

6

7

8

9

The submittals shall be Type 2 Working Drawings, except the shaft slurry technical assistance submittal shall be Type 1.

10 **6-19.3(3) Shaft Excavation**

11 In the first paragraph, the phrase "as approved by the Engineer" is deleted.

12

13 **6-19.3(3)B4 Temporary Telescoping Shaft Casing**

14 In the first paragraph, the first sentence of item number 1 is revised to read:

15

16

17

18

The Contractor shall submit the request to use temporary telescoping casing as a Type 2 Working Drawing.

19

20

21

19 **6-19.3(3)D Bottom of Shaft Excavation**

20 In the first sentence of the second paragraph, "approved" is revised to read "accepted".

21

22

23

24

22 **6-19.3(3)E Shaft Obstruction**

23 In the last sentence, "approved" is revised to read "accepted".

24

25

26

27

25 **6-19.3(3)F Voids Between Permanent Casing and Shaft Excavation**

26 In the last sentence, the words "and as approved by the Engineer" are deleted.

27

28

29

30

31

32

33

34

28 **6-19.3(3)G Operating Shaft Excavation Equipment From an Existing Bridge**

29 The second sentence is revised to read:

30

31

32

33

34

If necessary and safe to do so, and if the Contractor submits a Type 2 Working Drawing consisting of a written request in accordance with Section 6-01.6, the Engineer may permit operation of drilling equipment on a bridge.

35

36

37

38

39

40

41

42

35 **6-19.3(3)H Seals for Shaft Excavation in Water**

36 The first paragraph is revised to read:

37

38

39

40

41

42

When shafts are constructed in water and the Plans show a seal between the casing shoring and the upper portion of the permanent casing of the shaft, the Contractor shall construct a seal in accordance with the shaft installation narrative specified in Section 6-19.3(2)B Item 7.

43

44

45

46

47

48

The last sentence of the last paragraph is revised to read:

If the Contractor uses a casing shoring diameter other than that specified in the Plans, the Contractor shall submit a revised seal design in accordance with Section 6-19.3(2)B Item 7.

1 **6-19.3(4)C Slurry Sampling and Testing**

2 The second to last sentence of the first paragraph is revised to read:

3
4 Synthetic slurry shall conform to Section 9-36.2(2), the quality control plan included in
5 the shaft installation narrative in accordance with Section 6-19.3(2)B Item 4.
6

7 The second sentence of the second paragraph is revised to read:

8
9 These records shall be submitted as a Type 1 Working Drawing once the slurry system
10 has been established in the first drilled shaft on the project.
11

12 **6-19.3(4)E Maintenance of a Stable Shaft Excavation**

13 In the last sentence of the first paragraph, "approval" is revised to read "review".
14

15 **6-19.3(4)F Disposal of Slurry and Slurry Contacted Spoils**

16 This section is revised to read:

17
18 The Contractor shall manage and dispose of the slurry wastewater in accordance with
19 Section 8-01.3(1)C. Slurry-contacted spoils shall be disposed of as specified in the
20 shaft installation narrative in accordance with Section 6-19.3(2)B, item 8, and in
21 accordance with the following requirements:
22

- 23 1. Uncontaminated spoils in contact with water-only slurry may be disposed of as
24 clean fill.
25
- 26 2. Uncontaminated spoils in contact with water slurry mixed with flocculants
27 approved in Section 8-01.3(1)C3 may be disposed of as clean fill away from
28 areas that drain to surface waters of the state.
29
- 30 3. Spoils in contact with synthetic slurry or water slurry with polymer-based
31 additives or flocculants not approved in Section 8-01.3(1)C3 shall be disposed
32 of in accordance with Section 2-03.3(7)C. With permission of the Engineer, the
33 Contractor may re-use these spoils on-site.
34
- 35 4. Spoils in contact with mineral slurry shall be disposed of in accordance with
36 Section 2-03.3(7)C. With permission of the Engineer, the Contractor may re-
37 use these spoils on-site.
38

39 **6-19.3(5)A Steel Reinforcing Bar Cage Assembly**

40 In the second to last sentence of the first paragraph, the phrase "as approved by the
41 Engineer" is deleted.
42

43 **6-19.3(5)D Steel Reinforcing Bar Cage Support at Base of Shaft Excavation**

44 The first sentence is revised to read:

45
46 For shafts with temporary casing within 15-feet of the bottom of shaft elevation as
47 specified in the Plans, the Contractor may place quarry spalls or other rock backfill
48 acceptable to the Engineer into the shaft below the specified bottom of shaft elevation
49 as a means to support the steel reinforcing bar cage, provided that the materials and

1 means to accomplish this have been addressed by the shaft installation narrative, as
2 specified in Section 6-19.3(2)B Item 9.

3
4 **6-19.3(6)C Care for CSL Access Tubes From Erection Through CSL Testing**

5 In the last sentence, "as approved by the Engineer" is revised to read "acceptable to the
6 Engineer".

7
8 **6-19.3(8)C Requirements for Leaving Temporary Casing in Place**

9 Item number 1 (up until the colon) is revised to read:

- 10
11 1. The Contractor shall submit a Type 2E Working Drawing of the following
12 information:

13
14 In item C of item number 1, the phrase "in accordance with Section 6-01.9" is deleted.

15
16 Item number 2 is deleted.

17
18 **6-19.3(9)D Requirements to Continue Shaft Excavation Prior to Acceptance of
19 First Shaft**

20 This section is revised to read:

21
22 Except as otherwise noted, the Contractor shall not commence subsequent shaft
23 excavations until receiving the Engineer's acceptance of the first shaft, based on the
24 results and analysis of the crosshole sonic log testing for the first shaft. The Contractor
25 may commence subsequent shaft excavations prior to receiving the Engineer's
26 acceptance of the first shaft, provided the following condition is satisfied:

27
28 The Engineer permits continuing with shaft construction based on the Engineer's
29 observations of the construction of the first shaft, including, but not limited to,
30 conformance to the shaft installation narrative in accordance with Section 6-
31 19.3(2)B, and the Engineer's review of Contractor's daily reports and Inspector's
32 daily logs concerning excavation, steel reinforcing bar placement, and concrete
33 placement.

34
35 **6-19.3(9)F Contractor's Investigation and Remedial Action Plan**

36 This section is revised to read:

37
38 For all shafts determined to be unacceptable, the Contractor shall submit a Type 2
39 Working Drawing consisting of a plan for further investigation or remedial action. All
40 modifications to the dimensions of the shafts, as shown in the Plans, required by the
41 investigation and remedial action plan shall be supported by calculations and working
42 drawings. All investigation and remedial correction procedures and designs shall be
43 submitted.

44
45 **6-19.3(9)H Cored Holes**

46 The first sentence of the second paragraph is revised to read:

47
48 Prior to beginning coring, the Contractor shall submit Type 2 Working Drawings
49 consisting of the method and equipment used to drill and remove cores from shaft
50 concrete.

1
2
3
4
5
6
7
8
9
10
11
12
13
14
15
16
17
18
19
20
21
22
23
24
25
26
27
28
29
30
31
32
33
34
35
36
37
38
39
40
41
42
43
44
45
46

8-01.AP8

**Section 8-01, Erosion Control and Water Pollution Control
January 5, 2015**

8-01.2 Materials

This section is supplemented with the following new paragraph:

For all seed the Contractor shall furnish the Engineer with the following documentation:

- 1. The state or provincial seed dealer license and endorsements.
- 2. Copies of Washington State Department of Agriculture (WSDA) test results on each lot of seed. Test results must be within six months prior to the date of application.

8-01.3(1)A Submittals

The first sentence in the second paragraph is revised to read:

Modified TESC Plans shall meet all requirements of the current edition of the WSDOT Temporary Erosion and Sediment Control Manual M 3109.

8-01.3(1)C Water Management

Items number 1 through 3 are deleted.

This section is supplemented with the following new subsections:

8-01.3(1)C1 Disposal of Dewatering Water

When uncontaminated groundwater with a pH range of 6.5 – 8.5 is encountered in an excavation, it may be disposed of as follows:

- 1. When the turbidity of the groundwater is 25 NTU or less, it may bypass detention and treatment facilities and be discharged into the stormwater conveyance system at a rate that will not cause erosion or flooding in the receiving surface water body.
- 2. When the turbidity of the groundwater is not more than 25 NTU above or 125% of the turbidity of the site stormwater runoff, whichever is greater, the same detention and treatment facilities as used to treat the site runoff may be used.
- 3. When the turbidity of the groundwater is more than 25 NTU above or 125% of the turbidity of the site stormwater runoff, whichever is greater, the groundwater shall be treated separately from the site stormwater.

Alternatively, the Contractor may pursue independent disposal and treatment alternatives that do not use the stormwater conveyance system.

1
2
3
4
5
6
7
8
9
10
11
12
13
14
15
16
17
18
19
20
21
22
23
24
25
26
27
28
29
30
31
32
33
34
35
36
37
38
39
40
41
42
43
44
45
46
47
48
49
50

8-01.3(1)C2 Process Wastewater

Wastewater generated on-site as a byproduct of a construction process shall not be discharged to surface waters of the State. Some sources of process wastewater may be infiltrated in accordance with the NPDES Construction Stormwater General Permit.

8-01.3(1)C3 Shaft Drilling Slurry Wastewater

Wastewater generated on-site during shaft drilling activity shall be managed and disposed of in accordance with the requirements below. No shaft drilling slurry wastewater shall be discharged to surface waters of the State. Neither the sediment nor liquid portions of the shaft drilling slurry wastewater shall be contaminated, as detectable by visible or olfactory indication (e.g., chemical sheen or smell).

1. Water-only shaft drilling slurry or water slurry with approved flocculants may be infiltrated on-site. Flocculants used shall meet the requirements of Section 9-14.5(1) or shall be chitosan products listed as General Use Level Designation (GULD) on the Department of Ecology’s stormwater treatment technologies webpage for construction treatment. Infiltration is permitted if the following requirements are met:
 - a. Wastewater shall have a pH of 6.5 – 8.5 prior to discharge.
 - b. The source water meets drinking water standards or the Groundwater Quality Criteria listed in WAC 173-200-040.
 - c. The amount of flocculant added to the slurry shall be kept to the minimum needed to adequately settle out solids. The flocculant shall be thoroughly mixed into the slurry.
 - d. Infiltration locations shall be at least 100 feet away from surface waters, wells, on-site sewage systems, aquifer-sensitive recharge areas, sole source aquifers, and well-head protection areas. Before infiltration begins, there shall be a minimum of 5 feet of unsaturated soil between the soil surface receiving the wastewater for infiltration and the groundwater surface (i.e., saturated soil).
 - e. The slurry removed from the shaft shall be contained in a leak proof cell or tank for a minimum of 3 hours.
 - f. Within a 24 hour period, a maximum of 21,000 gallons of slurry wastewater may be infiltrated in an infiltration location. The infiltration rate shall be reduced if needed to prevent wastewater from leaving the infiltration location. The infiltration site shall be monitored regularly during infiltration activity. All wastewater discharged to the ground must fully infiltrate and discharges must stop before the end of each work day.
 - g. After infiltration activity is complete, loose sediment in the infiltration location that may have resulted from the infiltration activity or the removal of BMPs used to manage infiltration activity shall be stabilized to prevent mobilization by stormwater runoff.

1
2
3
4
5
6
7
8
9
10
11
12
13
14
15
16
17
18
19
20
21
22
23
24
25
26
27
28
29
30
31
32
33
34
35
36
37
38
39
40
41
42
43
44
45
46
47
48
49
50
51

- h. Drilling spoils and settled sediments remaining in the containment cell or tank shall be disposed of in accordance with Section 6-19.3(4)F.

- i. Infiltration locations shall be marked on the on-site temporary erosion and sediment control (TESC) plan sheets before the infiltration activity begins.

- j. Prior to infiltrating water-only shaft drilling slurry or water slurry with approved flocculants, the Contractor shall submit a Shaft Drilling Slurry Wastewater Management and Infiltration Plan as a Type 2 Working Drawing. This Plan shall be kept on-site, adapted if needed to meet the construction requirements, and updated to reflect what is being done in the field. The Working Drawing shall include, at a minimum, the following information:
 - i. Plan sheet showing the proposed infiltration location and all surface waters, wells, on-site sewage systems, aquifer-sensitive recharge areas, sole source aquifers, and well-head protection areas within 150 feet.
 - ii. The proposed elevation of soil surface receiving the wastewater for infiltration and the anticipated phreatic surface (i.e., saturated soil).
 - iii. The source of the water used to produce the slurry.
 - iv. The estimated total volume of wastewater to be infiltrated.
 - v. The approved flocculant to be used (if any).
 - vi. The controls or methods (e.g., trenches, traps, berms, silt fence, dispersion, or discharge metering devices) that will be used to prevent surface wastewater runoff from leaving the infiltration location. The Working Drawing shall include all pertinent design details (e.g., sizing of trenches or traps, placement or height of berms, application techniques) needed to demonstrate the proposed controls or methods are adequate to prevent surface wastewater runoff from leaving the infiltration location.
 - vii. The strategy for removing slurry wastewater from the shaft and containing the slurry wastewater once it has been removed from the shaft.
 - viii. The strategy for monitoring infiltration activity and adapting methods to ensure compliance.
 - ix. A contingency plan that can be implemented immediately if it becomes evident that the controls in place or methods being used are not adequate.
 - x. The strategy for cleaning up the infiltration location after the infiltration activity is done. Cleanup shall include stabilizing any loose sediment on the surface within the infiltration area generated

1 as a byproduct of suspended solids in the infiltrated wastewater or
2 soil disturbance associated with BMP placement and removal.

- 3
4 2. Shaft drilling mineral slurry, synthetic slurry, or slurry with polymer additives
5 not approved for infiltration shall be contained and disposed of by the
6 Contractor at an approved disposal facility in accordance with Section 2-
7 03.3(7)C. Spoils that have come into contact with mineral slurry shall be
8 disposed of in accordance with Section 6-19.3(4)F.
9

10 **8-01.3(1)C4 Management of Off-Site Water**

11 Prior to disruption of the normal watercourse, the Contractor shall intercept the off-site
12 surface water and pipe it either through or around the project site. This water shall not
13 be combined with on-site stormwater. It shall be discharged at its preconstruction
14 outfall point in such a manner that there is no increase in erosion below the site. The
15 Contractor shall submit a Type 2 Working Drawing consisting of the method for
16 performing this Work.
17

18 **8-01.3(2)A Preparation for Application**

19 This section's content is deleted and replaced with the following two new subsections:
20

21 **8-01.3(2)A1 Seeding**

22 Areas to be cultivated are shown in the Plans or specified in the Special Provisions.
23 The areas shall be cultivated to the depths specified to provide a reasonably firm but
24 friable seedbed. Cultivation shall take place no sooner than 2 weeks prior to seeding.
25

26 All areas to be seeded, including excavated slopes shall be compacted and prepared
27 unless otherwise specified or ordered by the Engineer. A cleated roller, crawler tractor,
28 or similar equipment that forms longitudinal depressions at least 2 inches deep shall be
29 used for compaction and preparation of the surface to be seeded.
30

31 The entire area shall be uniformly covered with longitudinal depressions formed
32 perpendicular to the natural flow of water on the slope. The soil shall be conditioned
33 with sufficient water so the longitudinal depressions remain in the soil surface until
34 completion of the seeding.
35

36 Prior to seeding, the finished grade of the soil shall be 1 inch below the top of all curbs,
37 junction and valve boxes, walks, driveways, and other Structures. The soil shall be in a
38 weed free and bare condition.
39

40 All bags of seed shall be brought to the site in sealed bags and shall have seed labels
41 attached showing the seed meets the Specifications. Seed which has become wet,
42 moldy, or otherwise damaged in transit or storage will not be accepted.
43

44 **8-01.3(2)A2 Temporary Seeding**

45 A cleated roller, crawler tractor, or similar equipment that forms longitudinal
46 depressions at least 2 inches deep shall be used for compaction and preparation of the
47 surface to be seeded. The entire area shall be uniformly covered with longitudinal
48 depressions formed perpendicular to the natural flow of water on the slope. The soil
49 shall be conditioned with sufficient water so the longitudinal depressions remain in the
50 soil surface until completion of the seeding.
51

1 **8-01.3(2)B Seeding and Fertilizing**

2 In the list in the second paragraph, item numbers 1-5 are revised to read:

- 3
- 4 1. A hydro seeder that utilizes water as the carrying agent, and maintains continuous
5 agitation through paddle blades. It shall have an operating capacity sufficient to
6 agitate, suspend, and mix into a homogeneous slurry the specified amount of seed
7 and water or other material. Distribution and discharge lines shall be large enough
8 to prevent stoppage and shall be equipped with a set of hydraulic discharge spray
9 nozzles that will provide a uniform distribution of the slurry.
 - 10
 - 11 2. Blower equipment with an adjustable disseminating device capable of maintaining
12 a constant, measured rate of material discharge that will ensure an even
13 distribution of seed at the rates specified.
 - 14
 - 15 3. Helicopters properly equipped for aerial seeding.
 - 16
 - 17 4. Power-drawn drills or seeders.
 - 18
 - 19 5. Areas in which the above methods are impractical may be seeded by hand
20 methods.
- 21

22 **8-01.3(2)C Liming**

23 This section including title is deleted in its entirety and replaced with the following:

24 **8-01.3(2)C Vacant**

25

26

27 **8-01.3(2)D Mulching**

28 The first sentence of the second paragraph is revised to read:

29

30 Distribution of straw mulch material shall be by means that utilizes forced air to blow
31 mulch material on seeded areas.

32

33 **8-01.3(11) Outlet Protection**

34 In the last sentence, "Section 9-13.6" is revised to read "Section 9-13.1(5)".

35

36 **8-01.4 Measurement**

37 In the twelfth paragraph, "liming" is deleted.

38

39 **8-01.5 Payment**

40 The bid item "Liming", per acre is deleted.

41

42 **8-02.AP8**

43 **Section 8-02, Roadside Restoration**

44 **January 5, 2015**

45 **8-02.3(1) Responsibility During Construction**

46 The last sentence of the second paragraph is revised to read:

47

1 This Work shall include keeping the planted and seeded areas free from insect
2 infestation, weeds or unwanted vegetation, litter, and other debris along with retaining
3 the finished grades and mulch in a neat uniform condition.
4

5 **8-02.3(2) Roadside Work Plan**

6 This section's title is revised to read:
7

8 **Work Plans**

9

10 This section's content is deleted in its entirety and replaced with the following new
11 subsections:
12

13 **8-02.3(2)A Roadside Work Plan**

14 Before starting any Work that disturbs the earth and as described in Sections 8-01, 8-
15 02 and 8-03, the Contractor shall submit a roadside work plan. The roadside work plan
16 shall be submitted as a Type 1 Working Drawing and shall define the Work necessary
17 to provide all Contract requirements, including: wetland excavation, soil preparation,
18 habitat structure placement, planting area preparation, seeding area preparation, bark
19 mulch and compost placement, seeding, planting, plant replacement, irrigation, and
20 weed control in narrative form.
21

22 The Roadside Work Plan shall also include a copy of the approved progress schedule.
23

24 **8-02.3(2)B Weed and Pest Control Plan**

25 The Weed and Pest Control Plan shall be submitted as a Type 1 Working Drawing.
26 The weed and pest control plan shall include scheduling and methods of all control
27 measures required under the Contract or proposed by the Contractor including soil
28 preparation methods to meet the required soil surface conditions in the planting, bark
29 mulch, and wetland areas. The weed control plan shall show general weed control
30 including hand, mechanical and chemical methods, timing, application of herbicides
31 including type, rate, use and timing, mowing, and noxious weed control. Target weeds
32 and unwanted vegetation to be removed shall be identified and listed in the weed
33 control plan.
34

35 The plan shall be prepared and signed by a licensed Commercial Pest Control
36 Operator or Consultant when chemical pesticides are proposed. The plan shall include
37 methods of weed control; dates of weed control operations; and the name, application
38 rate, and Material Safety Data Sheets of all proposed herbicides. In addition, the
39 Contractor shall furnish the Engineer with a copy of the current product label for each
40 pesticide and spray adjuvant to be used. These product labels shall be submitted with
41 the weed control plan for approval.
42

43 **8-02.3(2)C Plant Establishment Plan**

44 The Plant Establishment Plan shall be prepared in accordance with the requirements
45 of Section 8-02.3(13) and submitted as a Type 1 Working Drawing. The Plan shall
46 show the proposed scheduling of activities, materials, equipment to be utilized for the
47 first-year plant establishment, and an emergency contact person. The Plan shall
48 include the management of the irrigation system, when applicable. Should the plan
49 become unworkable at any time during the first-year plant establishment, the
50 Contractor shall submit a revised plan prior to proceeding with further Work.
51

1 **8-02.3(3) Weed and Pest Control**

2 This section is supplemented with the following new paragraph:

3
4 Grass, including grass applied in accordance with Section 8-01, growing within the
5 mulch ring of a plant shall be considered a weed and be controlled on the project in
6 accordance with the weed and pest control plan.
7

8 **8-02.3(4) Topsoil**

9 The last sentence of the first paragraph is revised to read:

10
11 After the topsoil has been spread, all large clods, hard lumps, and rocks 2 inches in
12 diameter and larger, and litter shall be raked up, removed, and disposed of by the
13 Contractor.
14

15 The following new paragraph is inserted after the first paragraph:

16
17 Topsoil stockpiled for project use shall be protected to prevent erosion and weed
18 growth. Weed growth on topsoil stockpile sites shall be immediately eliminated in
19 accordance with the approved Weed and Pest Control Plan.
20

21 **8-02.3(4)C Topsoil Type C**

22 The last sentence is revised to read:

23
24 Topsoil Type C shall meet the requirements of Sections 8-02.3(4), 8-02.3(4)B, and 9-
25 14.1(3).
26

27 **8-02.3(12) Completion of Initial Planting**

28 Item number 4 in the last paragraph is deleted.
29

30 **8-02.3(13) Plant Establishment**

31 The first sentence of the second paragraph is deleted.

32
33 The second paragraph is supplemented with the following new sentence:

34
35 The 1 calendar year shall be extended an amount equal to any periods where the
36 Contractor does not comply with the plant establishment plan.
37

38 The first sentence of the fourth paragraph is revised to read:

39
40 During the first year of plant establishment under PSIFE (Plant Selection Including
41 Plant Establishment), the Contractor shall meet monthly with the Engineer for the
42 purpose of joint inspection of the planting material on a mutually agreed upon
43 schedule.
44

45 The last two paragraphs are deleted.
46

47 **8-02.4 Measurement**

48 This section is supplemented with the following:

49
50 Plant selection will be measured per each.

1
2 PSIPE __ (Plant Selection Including Plant Establishment) will be measured per each.

3
4 **8-02.5 Payment**

5 The paragraph following the bid item "Topsoil Type ____", per acre is revised to read:

6
7 The unit Contract price per acre for "Topsoil Type ____" shall be full payment for all
8 costs for the specified Work.

9
10 The bid item "PSIPE ____", per each and the paragraph following the bid item are revised to
11 read:

12
13 "PSIPE ____", per each.

14
15 The unit Contract price for "Plant Selection ____", per each, and "PSIPE ____", per each,
16 shall be full pay for all Work necessary for weed control within the planting area,
17 planting area preparation, fine grading, planting, cultivating, plant storage and
18 protection, fertilizer and root dip, staking, cleanup, and water necessary to complete
19 planting operations as specified to the end of first year plant establishment.

20
21 The bid item "Plant Establishment - ____ Year" is deleted.

22
23 **8-04.AP8**

24 **Section 8-04, Curbs, Gutters, and Spillways**
25 **January 5, 2015**

26 **8-04.2 Materials**

27 The referenced section for the following item is revised to read:

28
29 Hand Placed Riprap 9-13.1(4)

30
31 **8-04.3(1) Cement Concrete Curbs, Gutters, and Spillways**

32 The first sentence in the fourth paragraph is revised to read:

33
34 Expansion joints in the curb or curb and gutter shall be spaced as shown in the Plans,
35 and placed at the beginning and ends of curb returns, drainage Structures, bridges,
36 and cold joints with existing curbs and gutters.

37
38 In the third sentence of the fourth paragraph, "¼-inch" is revised to read "⅜-inch".

39
40 **8-04.3(1)A Extruded Cement Concrete Curb**

41 The second sentence in the second paragraph is revised to read:

42
43 Cement concrete curbs shall be anchored to the existing pavement by placing steel
44 reinforcing bars 1 foot on each side of every joint.

45
46 The third paragraph is revised to read:

47
48 Steel reinforcing bars shall meet the dimensions shown in the Standard Plans.

1
2
3
4
5
6
7
8
9
10
11
12
13
14
15
16
17
18
19
20
21
22
23
24
25
26
27
28
29
30
31
32
33
34
35
36
37
38
39
40
41
42
43
44
45

8-09.AP8

**Section 8-09, Raised Pavement Markers
April 7, 2014**

8-09.3(6) Recessed Pavement Marker

The following sentence is inserted after the first sentence of the first paragraph:

The Contractor shall ensure that grinding of the pavement does not result in any damage, (e.g. chipping, spalling or raveling) to the pavement to remain.

8-11.AP8

**Section 8-11, Guardrail
April 7, 2014**

8-11.3(1) Beam Guardrail

After the below Amendments to 8-11.3(1)F and 8-11.3(1)G are applied, this section is supplemented with the following new sub-section:

8-11.3(1)F Removing and Resetting Beam Guardrail

The Contractor shall remove and reset existing guardrail posts, rail element, hardware and blocks to the location shown in the Plans. The mounting height of reset rail element shall be at the height shown in the Plans. The void caused by the removal of the post shall be backfilled and compacted.

The Contractor shall remove and replace any existing guardrail posts and blocks that are not suited for re-use, as staked by the Engineer. The void caused by the removal of the post shall be backfilled and compacted. The Contractor shall then furnish and install a new guardrail post to provide the necessary mounting height.

8-11.3(1)A Erection of Posts

The second paragraph in this section is deleted.

8-11.3(1)C Terminal and Anchor Installation

The last sentence in the last paragraph is deleted.

8-11.3(1)F Plans

This section number is revised to:

8-11.3(1)G

8-11.3(1)G Guardrail Construction Exposed to Traffic

This section number is revised to:

8-11.3(1)H

1 **8-18.AP8**

2 **Section 8-18, Mailbox Support**
3 **August 4, 2014**

4 **8-18.3(1) Type 3 Mailbox Support**

5 In the third paragraph, the first sentence is revised to read:

6

7 With the Engineer's consent, a Type 3 Mailbox Support design, made of steel or other
8 durable material, that meets the NCHRP 350 or the Manual for Assessing Safety
9 Hardware (MASH) crash test criteria may be used in place of the design shown in the
10 *Standard Plans*.

11

12 **8-20.AP8**

13 **Section 8-20, Illumination, Traffic Signal Systems, Intelligent Transportation**
14 **Systems, and Electrical**
15 **April 6, 2015**

16 **8-20.2(1) Equipment List and Drawings**

17 The second sentence of the second paragraph is revised to read:

18

19 Supplemental data would include such items as catalog cuts, product Specifications,
20 shop drawings, wiring diagrams, etc.

21

22 The third paragraph (up until the colon) is revised to read:

23

24 If the luminaires are not listed in the Qualified Products List, the Contractor shall submit
25 the following information for each different type of luminaire required on the Contract:

26

27 The fourth paragraph (up until the colon) is revised to read:

28

29 The Contractor shall submit for approval Type 3E Working Drawings in accordance
30 with Section 1-05.3 for each of the following types of standards called for on this
31 project:

32

33 The fifth paragraph is revised to read:

34

35 The Contractor will not be required to submit shop drawings for approval for light
36 standards and traffic signal standards conforming to the preapproved plans listed in the
37 Special Provisions. The Contractor may use preapproved plans posted on the
38 WSDOT website with a more current revision date than published in the Special
39 Provisions.

40

41 **8-20.3(1) General**

42 The following six new paragraphs are inserted after the second paragraph:

43

44 If a portion of an existing communication conduit system is damaged due to the
45 Contractor's activities, the affected system shall be restored to original condition.
46 Conduit shall be repaired. Communication cables shall be replaced and the

1 communication system shall be made fully operational within 24 hours of being
2 damaged.

3
4 Damaged communication cable shall be replaced between existing termination or
5 splice points. No additional termination or splice points will be allowed. An existing
6 termination or splice point is defined as a location where all existing fiber strands or
7 twisted pair wires are terminated or spliced at one point. Communication cable shall
8 be defined as either copper twisted pair or fiber optic cables. The Contractor may use
9 temporary splices to restore Contracting Agency communication systems until the
10 permanent communication cable system is restored.

11
12 When damage to an existing communication system has occurred, the Contractor shall
13 perform the following in addition to other restoration requirements:

- 14
15 1. Inspect the communication raceway system including locate wire or tape to
16 determine the extent of damage.
- 17
18 2. Contact the Engineer for Fiber Optic Cable and Twisted Pair (TWP) Copper
19 Cable acceptance testing requirements and communication system restoration
20 requirements.
- 21
22 3. Initially perform the acceptance tests to determine the extent of damage and
23 also perform the acceptance tests after repairs are completed. Provide written
24 certification that the communication cable system, including the locate wire or
25 tape, is restored to test standard requirements.

26
27 Communication cables shall be restored by Contractor personnel that are WSDOT
28 prequalified for communication installation work. Restoration shall be considered
29 electrical work when the path of the communication system interfaces with electrical
30 systems. Electrical work of this nature shall be performed by Contractor personnel that
31 are WSDOT prequalified for work on both electrical and communication systems.

32
33 If the Contractor or Subcontractors are unable or unqualified to complete the
34 restoration work, the Engineer may have the communication or electrical systems
35 restored by other means and subtract the cost from the money that will be or is due the
36 Contractor.

37
38 When field repair of existing conduit, innerduct or outerduct is required, the repair kits
39 shall be installed per manufacturer's recommendations. Repair kits and each
40 connection point between the repair kit and the existing raceway system shall be
41 sealed to prevent air leakage during future cable installation.

42 43 **8-20.3(8) Wiring**

44 The second sentence in the eleventh paragraph is revised to read:

45
46 Every conductor at every wire termination, connector, or device shall have an
47 approved wire marking sleeve bearing, as its legend, the circuit number indicated in
48 the Contract.

49 50 **8-20.3(13)A Light Standards**

51 In the third paragraph, the last sentence of item number 1 is revised to read:

1
2 Conduit shall extend a maximum of 1 inch above the top of the foundation, including
3 grounding end bushing or end bell bushing.

4
5 In the fourth paragraph, the second sentence of item number 1 is revised to read:

6
7 Conduits shall be cut to a maximum height of 2 inches above the foundation including
8 grounding end bushing or end bell bushing.

9
10 **8-21.AP8**

11 **Section 8-21, Permanent Signing**
12 **April 6, 2015**

13 **8-21.3(9)F Foundations**

14 The first sentence of the first paragraph is revised to read:

15
16 The excavation and backfill shall conform to the requirements of Section 2-09.3.

17
18 **8-22.AP8**

19 **Section 8-22, Pavement Marking**
20 **April 6, 2015**

21 **8-22.3(6) Removal of Pavement Markings**

22 The second and third sentences of the first paragraph are revised to read:

23
24 Grinding to remove pavement markings is allowed prior to application of a Bituminous
25 Surface Treatment. Grinding to remove pavement marking from hot mix asphalt and
26 cement concrete pavements is allowed to a depth just above the pavement surface,
27 then water blasting or shot blasting shall be required to remove the remaining
28 markings.

29
30 **8-23.AP8**

31 **Section 8-23, Temporary Pavement Markings**
32 **January 5, 2015**

33 This section's content is deleted in its entirety and replaced with the following new sub-
34 sections:

35
36 **8-23.1 Description**

37 The Work consists of furnishing, installing, and removing temporary pavement
38 markings. Temporary pavement markings shall be provided where noted in the Plans;
39 for all lane shifts and detours resulting from construction activities; or when permanent
40 markings are removed because of construction operations.

1 **8-23.2 Materials**

2 Materials for temporary markings shall be paint, plastic, tape, raised pavement markers
3 or flexible raised pavement markers. Materials for pavement markings shall meet the
4 following requirements:

5

6	Raised Pavement Markers	9-21
7	Temporary Marking Paint	9-34.2(6)
8	Plastic	9-34.3
9	Glass Beads for Pavement Marking Materials	9-34.4
10	Temporary Pavement Marking Tape	9-34.5
11	Temporary Flexible Raised Pavement Markers	9-34.6

12

13 **8.23.3 Construction Requirements**

14

15 **8-23.3(1) General**

16 The Contractor shall select the type of pavement marking material in accordance
17 with the Contract.

18

19 **8-23.3(2) Preliminary Spotting**

20 All preliminary layout and marking in preparation for application or removal of
21 temporary pavement markings shall be the responsibility of the Contractor.

22

23 **8-23.3(3) Preparation of Roadway Surface**

24 Surface preparation for temporary pavement markings shall be in accordance with
25 the manufacturer's recommendations.

26

27 **8-23.3(4) Pavement Marking Application**

28

29 **8-23.3(4)A Temporary Pavement Markings – Short Duration**

30 Temporary pavement markings – short duration shall meet the following
31 requirements:

32

33 **Temporary Center Line** – A BROKEN line used to delineate adjacent
34 lanes of traffic moving in opposite directions. The broken pattern shall be
35 based on a 40-foot unit, consisting of a 4-foot line with a 36-foot gap if
36 paint or tape is used. If temporary raised pavement markers are used,
37 the pattern shall be based on a 40-foot unit, consisting of a grouping of
38 three temporary raised pavement markers, each spaced 3 feet apart, with
39 a 34 foot gap.

40

41 **Temporary Edge Line** – A SOLID line used on the edges of Traveled
42 Way. The line shall be continuous if paint or tape is used. If temporary
43 raised pavement markers are used, the line shall consist of markers
44 installed continuously at 5-foot spacing.

45

46 **Temporary Lane Line** – A BROKEN line used to delineate adjacent
47 lanes with traffic traveling in the same direction. The broken pattern shall
48 be based on a 40-foot unit, consisting of a 4-foot line with a 36-foot gap, if
49 paint or tape is used. If temporary raised pavement markers are used,
50 the pattern shall be based on a 40-foot unit, consisting of a grouping of

1 three temporary raised pavement markers, each spaced 3 feet apart, with
2 a 34 foot gap.

3
4 Lane line and right edge line shall be white in color. Center line and left edge
5 line shall be yellow in color. Edge lines shall be installed only if specifically
6 required in the Contract. All temporary pavement markings shall be
7 retroreflective.

8
9 **8-23.3(4)A1 Temporary Pavement Marking Paint**

10 Paint used for short duration temporary pavement markings shall be
11 applied in one application at a thickness of 15 mils or 108 square feet per
12 gallon. Glass beads shall be in accordance with Section 8-22.3(3)G.

13
14 **8-23.3(4)A2 Temporary Pavement Marking Tape**

15 Application of temporary pavement marking tape shall be in conformance
16 with the manufacturer's recommendations.

17
18 Black mask pavement marking tape shall mask the existing line in its
19 entirety.

20
21 **8-23.3(4)A3 Temporary Raised Pavement Markers**

22 Temporary raised pavement markers are not allowed on bituminous
23 surface treatments.

24
25 **8-23.3(4)A4 Temporary Flexible Raised Pavement Markers**

26 Flexible raised pavement markers are required for new applications of
27 bituminous surface treatments. Flexible raised pavement markers are
28 not allowed on other pavement types unless otherwise specified or
29 approved by the Engineer. Flexible raised pavement markers shall be
30 installed with the protective cover in place. The cover shall be removed
31 immediately after spraying asphaltic material.

32
33 **8-23.3(4)B Temporary Pavement Markings – Long Duration**

34 Application of paint, pavement marking tape and plastic for long duration
35 pavement markings shall meet the requirements of Section 8-22.3(3);
36 application of raised pavement markers shall meet the requirements of
37 Section 8-09.3; and application of flexible pavement markings shall be in
38 conformance with the manufacturer's recommendations.

39
40 **8-23.3(4)C Tolerance for Lines**

41 Tolerance for lines shall conform to Section 8-22.3(4).

42
43 **8-23.3(4)D Maintenance of Pavement Markings**

44 Temporary pavement markings shall be maintained in serviceable condition
45 throughout the project until permanent pavement markings are installed. As
46 directed by the Engineer; temporary pavement markings that are damaged,
47 including normal wear by traffic, shall be repaired or replaced immediately.
48 Repaired and replaced pavement markings shall meet the requirements for
49 the original pavement marking.
50

1 **8-23.3(4)E Removal of Pavement Markings**

2 Removal of temporary paint is not required prior to paving; all other temporary
3 pavement markings shall be removed.
4

5 All temporary pavement markings that are required on the wearing course
6 prior to construction of permanent pavement markings and are not a part of
7 the permanent markings shall be completely removed concurrent with or
8 immediately subsequent to the construction of the permanent pavement
9 markings. Temporary flexible raised pavement markers on bituminous surface
10 treatment pavements shall be cut off flush with the surface if their location
11 conflicts with the alignment of the permanent pavement markings. All other
12 temporary pavement markings shall be removed in accordance with Section
13 8-22.3(6).
14

15 All damage to the permanent Work caused by removing temporary pavement
16 markings shall be repaired by the Contractor at no additional cost to the
17 Contracting Agency.
18

19 **8-23.4 Measurement**

20 Temporary pavement markings will be measured by the linear foot of each installed
21 line or grouping of markers, with no deduction for gaps in the line or markers and no
22 additional measurement for the second application of paint required for long duration
23 paint lines. Short duration and long duration temporary pavement markings will be
24 measured for the initial installation only.
25

26 **8-23.5 Payment**

27 Payment will be made in accordance with Section 1-04.1, for each of the following Bid
28 items that are included in the Proposal:
29

30 "Temporary Pavement Marking – Short Duration", per linear foot.

31
32 "Temporary Pavement Marking – Long Duration", per linear foot.
33

34 The unit Contract price per linear foot for "Temporary Pavement Marking – Short
35 Duration" and "Temporary Pavement Marking – Long Duration" shall be full pay for
36 all Work.
37

38 **9-01.AP9**

39 **Section 9-01, Portland Cement**
40 **January 5, 2015**

41 **9-01.2(3) Low Alkali Cement**

42 This section is revised to read:
43

44 When low alkali portland cement is required, the percentage of alkalis in the cement
45 shall not exceed 0.60 percent by weight calculated as Na_2O plus $0.658 \text{ K}_2\text{O}$. This
46 limitation shall apply to all types of portland cement.
47

1 **9-01.2(4) Blended Hydraulic Cement**

2 The first paragraph is revised to read:

3
4 Blended hydraulic cement shall be either Type IP(X)(MS) or Type IS(X)(MS) cement
5 conforming to AASHTO M 240 or ASTM C 595, except that the portland cement used
6 to produce blended hydraulic cement shall not contain more than 0.75 percent alkalis
7 by weight calculated as Na_2O plus $0.658 \text{ K}_2\text{O}$ and shall meet the following additional
8 requirements:

- 9
10 1. Type IP(X)(MS) - Portland-Pozzolan Cement where (X) equals the targeted
11 percentage of fly ash, the fly ash is limited to a maximum of 35 percent by
12 weight of the cementitious material; (MS) indicates moderate sulfate
13 resistance.
14
15 2. Type IS(X)(MS) - Portland Blast- Furnace Slag Cement, where: (X) equals the
16 targeted percentage of ground granulated blast-furnace slag, the ground
17 granulated blast furnace slag is limited to a maximum of 50 percent by weight
18 of the cementitious material; (MS) indicates moderate sulfate resistance.
19

20 The first sentence of the second paragraph is revised to read:

21
22 The source and weight of the fly ash or ground granulated blast-furnace slag shall be
23 certified on the cement mill test report or cement certificate of analysis and shall be
24 reported as a percent by weight of the total cementitious material.
25

26 **9-01.3 Tests and Acceptance**

27 The first paragraph is revised to read:

28
29 Cement may be accepted by the Engineer based on the cement mill test report number
30 or cement certificate of analysis number indicating full conformance to the
31 Specifications. All shipments of the cement to the Contractor or concrete supplier shall
32 identify the applicable cement mill test report number or cement certificate of analysis
33 number and shall be provided by the Contractor or concrete supplier with all concrete
34 deliveries.
35

36 The second paragraph is revised to read:

37
38 Cement producers/suppliers that certify portland cement or blended cement shall
39 participate in the Cement Acceptance Program as described in WSDOT Standard
40 Practice QC 1.
41

42 **9-01.4 Storage on the Work Site**

43 This section is revised to read:

44
45 At the request of the Engineer, the Contractor shall provide test data to show that
46 cement stored on site for longer than 60 days meets the requirements of 9-01. Tests
47 shall be conducted on samples taken from the site in the presence of the Engineer.
48 Test results that meet the requirements of 9-01 shall be valid for 60 days from the date
49 of sampling, after which the Engineer may require further testing.
50

1 **9-02.AP9**

2 **Section 9-02, Bituminous Materials**
 3 **April 6, 2015**

4 **9-02.1(4) Performance Graded Asphalt Binder (PGAB)**

5 The first paragraph is supplemented with the following:

6

7 For HMA with greater than 20 percent RAP by total weight of HMA or any amount of
 8 RAS the new asphalt binder, recycling agent and recovered asphalt (RAP and/or RAS)
 9 when blended in the proportions of the mix design shall meet the PGAB requirements
 10 of AASHTO M 320 Table 1 for the grade of asphalt binder specified by the Contract.

11

12 This section is supplemented with the following:

13

14 The recycling agent used to rejuvenate the recovered asphalt from recycled asphalt
 15 pavement (RAP) and reclaimed asphalt shingles (RAS) shall meet the specifications in
 16 Table 1:

17

Table 1		RA 1		RA 5		RA 25	
Test	ASTM Test Method	Min.	Max.	Min.	Max.	Min.	Max.
Viscosity @ 140°F cSt	D2170 or D2171	50	150	200	800	1000	4000
Flashpoint COC, °F	D92	400		400		400	
Saturates, Wt. %	D2007		30		30		30
Specific Gravity	D70 or D2198	Report		Report		Report	
Tests on Residue from RTFC	D2872						
Viscosity Ratio ¹			3		3		3
Mass Change ± %			4		4		4
¹ Viscosity Ratio = $\frac{\text{RTFC Viscosity @ 140°F, cSt}}{\text{Original Viscosity @ 140°F, cSt}}$							

18

19

20 **9-02.1(6)A Polymerized Cationic Emulsified Asphalt CRS-2P**

21 In the ninth row of the table, "Test" is revised to read "Tests".

22

23 The eleventh row in the table is revised to read:

24

Elastic Recovery %	T 301 ²	50	
--------------------	--------------------	----	--

25

26 The last two rows of the table are deleted.

27

1 Footnote 2 below the table is revised to read:

2
3 2 The residue material for T 301 shall come from the modified distillation per note 1.

4
5 Footnote 3 below the table is deleted.

6
7 The last paragraph is deleted.

8
9 **9-03.AP9**

10 **Section 9-03, Aggregates**

11 **April 6, 2015**

12 **9-03.1(2)C Use of Substandard Gradings**

13 This section including title is deleted in its entirety and replaced with the following:

14
15 **Vacant**

16
17 **9-03.1(4)C Grading**

18 In the second paragraph, the first sentence is deleted.

19
20 The third paragraph is deleted.

21
22 **9-03.1(5)B Grading**

23 The last paragraph is revised to read:

24
25 The Contracting Agency may sample each aggregate component prior to introduction
26 to the weigh batcher or as otherwise determined by the Engineer. Each component will
27 be sieve analyzed separately in accordance with WSDOT FOP for WAQTC/AASHTO
28 Test Method T-27/11. All aggregate components will be mathematically re-combined
29 by the proportions (percent of total aggregate by weight) provided by the Contractor on
30 Concrete Mix Design Form 350-040.

31
32 **9-03.8(1) General Requirements**

33 The first paragraph up until the colon is revised to read:

34
35 Preliminary testing of aggregates for source approval shall meet the following test
36 requirements:

37
38 The list in the first paragraph is supplemented with the following:

39
40 Sand Equivalent 45 min.

41
42 The following new paragraph is inserted after the first paragraph:

43
44 Aggregate sources that have 100 percent of the mineral material passing the No. 4
45 sieve shall be limited to no more than 5 percent of the total weight of aggregate.

46
47 **9-03.8(2) HMA Test Requirements**

48 The second paragraph (up until the colon) is revised to read:

1
2 The mix design shall produce HMA mixtures when combined with RAP, RAS, coarse
3 and fine aggregate within the limits set forth in Section 9-03.8(6) and mixed in the
4 laboratory with the designated grade of asphalt binder, using the Superpave gyratory
5 compactor in accordance with WSDOT FOP for AASHTO T 312, and at the required
6 gyrations for N initial, N design, and N maximum with the following properties:
7

8 The third paragraph is revised to read:
9

10 The mix criteria for Hamburg Wheel-Track Testing and Indirect Tensile Strength do not
11 apply to HMA accepted by commercial evaluation.
12

13 **9-03.8(3)B Gradation – Recycled Asphalt Pavement and Mineral Aggregate**

14 This section is supplemented with the following:
15

16 For HMA with greater than 20 percent RAP by total weight of HMA the RAP shall be
17 processed to ensure that 100 percent of the material passes a sieve twice the size of
18 the maximum aggregate size for the class of mix to be produced.
19

20 When any amount of RAS is used in the production of HMA the RAS shall be milled,
21 crushed or processed to ensure that 100 percent of the material passes the ½ inch
22 sieve. Extraneous materials in RAS such as metals, glass, rubber, soil, brick, tars,
23 paper, wood and plastic shall not exceed 2.0 percent by mass as determined on
24 material retained on the No. 4 sieve.
25

26 **9-03.14(3) Common Borrow**

27 This section is revised to read:
28

29 Material for common borrow shall consist of granular or nongranular soil and/or
30 aggregate which is free of deleterious material. Deleterious material includes wood,
31 organic waste, coal, charcoal, or any other extraneous or objectionable material. The
32 material shall not contain more than 3 percent organic material by weight. The
33 plasticity index shall be determined using test method AASHTO T 89 and AASHTO
34 T 90.
35

36 The material shall meet one of the options in the soil plasticity table below.
37

38 Soil Plasticity Table
39

Option	Sieve No.	Percent Passing	Plasticity Index
1	200	0 - 12	N/A
2	200	12.1 - 35	6 or Less
3	200	Above 35	0

40 All percentages are by weight.
41

1 If requested by the Contractor, the plasticity index may be increased with the approval
2 of the Engineer.

3

4 **9-03.14(4) Gravel Borrow for Structural Earth Wall**

5 In the second table, the row beginning with "pH" is revised to read:

6

pH	WSDOT Test Method T 417	4.5 - 9	5 - 10
----	-------------------------	---------	--------

7

8 **9-03.21(1) General Requirements**

9 The following new paragraph is inserted after the second paragraph:

10

11 Reclaimed asphalt shingles samples shall contain less than the maximum percentage
12 of asbestos fibers based on testing procedures and frequencies established in
13 conjunction with the specifying jurisdiction and state or federal environmental
14 regulatory agencies.

15

16 **9-04.AP9**

17 **Section 9-04, Joint and Crack Sealing Materials**

18 **January 5, 2015**

19 **9-04.1(4) Elastomeric Expansion Joint Seals**

20 In this section, "AASHTO M 220" is revised to read "ASTM D 2628".

21

22 **9-04.2(1) Hot Poured Joint Sealants**

23 In the first paragraph, "AASHTO M 324" is revised to read "ASTM D 6690".

24

25 **9-04.2(2) Poured Rubber Joint Sealer**

26 In item number 9, "WSDOT Test Method No. 412" is revised to read "ASTM D 5329".

27

28 **9-05.AP9**

29 **Section 9-05, Drainage Structures and Culverts**

30 **April 7, 2014**

31 **9-05.13 Ductile Iron Sewer Pipe**

32 The first paragraph is deleted.

33

34 **9-06.AP9**

35 **Section 9-06, Structural Steel and Related Materials**

36 **January 5, 2015**

37 **9-06.5(4) Anchor Bolts**

38 The third sentence of the second paragraph is revised to read:

39

40 Nuts for ASTM F 1554 Grade 36 or 55 black or galvanized anchor bolts shall conform
41 to ASTM A 563, Grade A or DH.

1
2
3
4
5
6
7
8
9
10
11
12
13
14
15
16
17
18
19
20
21
22
23
24
25
26
27
28
29
30
31
32
33
34
35
36
37
38
39
40
41
42
43
44
45
46

9-07.AP9

**Section 9-07, Reinforcing Steel
January 6, 2014**

**9-07.5(1) Epoxy-Coated Dowel Bars (for Cement Concrete Pavement
Rehabilitation)**

This section is revised to read:

Epoxy-coated dowel bars shall be round plain steel bars of the dimensions shown in the Standard Plans. They shall conform to AASHTO M 31, Grade 60 or ASTM A 615, Grade 60 and shall be coated in accordance with ASTM A 1078 Type 2 coating, except that the bars may be cut to length after being coated. Cut ends shall be coated in accordance with ASTM A 1078 with a patching material that is compatible with the coating, inert in concrete and recommended by the coating manufacturer. The thickness of the epoxy coating shall be 10 mils plus or minus 2 mils. The Contractor shall furnish a written certification that properly identifies the coating material, the number of each batch of coating material used, quantity represented, date of manufacture, name and address of manufacturer, and a statement that the supplied coating material meets the requirements of ASTM A 1078 Type 2 coating. Patching material, compatible with the coating material and inert in concrete and recommended by the manufacturer shall be supplied with each shipment for field repairs by the Contractor.

9-07.5(2) Corrosion Resistant Dowel Bars (for Cement Concrete Pavement)

This section's title is revised to read:

**9-07.5(2) Corrosion Resistant Dowel Bars (for Cement Concrete Pavement and
Cement Concrete Pavement Rehabilitation)**

9-08.AP9

**Section 9-08, Paints and Related Materials
January 5, 2015**

9-08.1(2)H Top Coat, Single Component, Moisture-Cured Polyurethane

The second paragraph is revised to read:

Color and Gloss: As specified in the Plans or Special Provisions

The last item in the requirements list is revised to read:

The top coat shall be a gloss or semi-gloss

9-08.1(8) Standard Colors

The second paragraph is deleted.

The third paragraph is revised to read:

1 Unless otherwise specified, all top or finish coats shall be gloss or semi-gloss, with the
2 paint falling within the range of greater than 70 for gloss and 35 to 70 for semi-gloss on
3 the 60-degree gloss meter.
4

5 **9-09.AP9**

6 **Section 9-09, Timber and Lumber**
7 **January 6, 2014**

8 **9-09.3(1) General Requirements**

9 The fourth paragraph is revised to read:

10
11 All orders of treated timber and lumber shall be accompanied by a Certificate of
12 Treatment record. The Certificate of Treatment showing conformance to this
13 specification and AWPA standards shall include the following information:

14
15 Name and location of the wood preserving company,

16
17 Customer identification,

18
19 Date of treatment and charge number,

20
21 Type of chemical used and amount of retention,

22
23 Treating process and identification of the Specification used,

24
25 Boring records verifying treatment penetration for timber and lumber with a
26 nominal dimension of 6" x 6" or larger,

27
28 Description of material that was treated, and

29
30 Signature of a responsible plant official.
31

32 The fifth paragraph is deleted.

33
34 The first sentence in the last paragraph is revised to read:

35
36 All timber and lumber to be used in aquatic environments, unless specified otherwise in
37 the Contract, shall be chemically treated using Western Wood Preservers Institute Best
38 Management Practices (BMPs).
39

40 **9-10.AP9**

41 **Section 9-10, Piling**
42 **March 3, 2014**

43 **9-10.5 Steel Piling**

44 This section is revised to read:
45

1 The material for rolled steel piling H-piling and pile splices shall conform to ASTM A 36,
2 ASTM A 572 or ASTM A 992. The material for steel pipe piling and splices shall
3 conform to one of the following requirements except as specifically noted in the Plans:
4

- 5 1. API 5L Grade X42 or X52 material may be used for longitudinal seam welded
6 or helical (spiral) seam submerged-arc welded pipe piles of any diameter.
7
- 8 2. ASTM A 252 Grade 2 or 3 material may be used for longitudinal seam welded
9 or helical (spiral) seam submerged-arc welded pipe piles of any diameter. For
10 the purposes of welding and prequalification of base metal, steel pipe pile
11 designated as ASTM A 252 may be treated as prequalified provided the
12 chemical composition conforms to a prequalified base metal classification
13 listed in Table 3.1 of the AWS D1.1/D1.1M, latest edition, Structural Welding
14 Code, the grade of pipe piling meets or exceeds the grade specified in the
15 Plans, and the carbon equivalent (CE) is a maximum of 0.45-percent.
16
- 17 3. ASTM A 572 or ASTM A 588 material may be used for longitudinal seam
18 welded piles of any diameter.
19

20 For helical (spiral) seam submerged-arc welded pipe piles, the maximum radial offset
21 of strip/plate edges shall be 1/8 inch. The offset shall be transitioned with a taper weld
22 and the slope shall not be less than a 1 in 2.5 taper. The weld reinforcement shall not
23 be greater than 3/16 inches and misalignment of weld beads shall not exceed 1/8 inch.
24

25 Steel soldier piles, and associated steel bars and plates, shall conform to ASTM A 36,
26 ASTM A 572 or ASTM A 992, except as otherwise noted in the Plans.
27

28 All steel piling may be accepted by the Engineer based on the Manufacturer's
29 Certificate of Compliance submitted in accordance with Section 1-06.3. The
30 manufacturer's certificate of compliance submittal for steel pipe piles shall be
31 accompanied by certified mill test reports, including chemical analysis and carbon
32 equivalence, for each heat of steel used to fabricate the steel pipe piling.
33

34 **9-13.AP9**

35 **Section 9-13, Riprap, Quarry Spalls, Slope Protection, and Rock for Erosion** 36 **and Scour Protection and Rock Walls** 37 **January 5, 2015**

38 This section's content is deleted.
39

40 **9-13.1 Loose Riprap**

41 This section's content, including title and subsections, is revised to read the following:
42

43 **9-13.1 Riprap and Quarry Spalls**

44 **9-13.1(1) General**

45 Riprap and quarry spalls shall consist of broken stone or broken concrete rubble
46 and shall be free of rock fines, soil, or other extraneous material. Concrete rubble
47 shall not be contaminated by foreign materials such as fibers, wood, steel, asphalt,
48

1 sealant, soil, plastic and other contaminants or deleterious material. Concrete
 2 rubble that is imported to the job site will require testing and certification for toxicity
 3 characteristics per Section 9-03.21(1).
 4

5 The grading of the riprap shall be determined by the Engineer by visual inspection
 6 of the load before it is dumped into place, or, if so ordered by the Engineer, by
 7 dumping individual loads on a flat surface and sorting and measuring the
 8 individual rocks contained in the load. Should the riprap contain insufficient spalls,
 9 as defined in Section 9-13.1(5), the Contractor shall furnish and place
 10 supplementary spall material.
 11

12 Riprap and quarry spalls shall be free from segregation, seams, cracks, and other
 13 defects tending to destroy its resistance to weather and shall conform to the
 14 following requirements for quality.
 15

Aggregate Property	Test Method	Requirement
Degradation Factor	WSDOT T 113	15 minimum
Los Angeles Wear, 500 Rev.	AASHTO T 96	50% maximum
Specific Gravity, SSD	AASHTO T 85	2.55 minimum

16
 17 **9-13.1(2) Heavy Loose Riprap**

18 Heavy loose riprap shall meet the following requirements for grading:
 19

	Minimum Size	Maximum Size
40% to 90%	1 ton (½ cubic yd.)	
70% to 90%	300 lbs. (2 cu. ft.)	
10% to 30%	3 inch	50 lbs. (spalls)

20
 21
 22 **9-13.1(3) Light Loose Riprap**

23 Light loose riprap shall meet the following requirements for grading:
 24

	Size Range	Maximum Size
20% to 90%	300 lbs. to 1 ton (2 cu. ft. to ½ cu. yd.)	
15% to 80%	50 lbs. to 1 ton (½ cu. ft. to ½ cu. yd.)	
10% to 20%	3 inch	50 lbs. (spalls)

25
 26 **9-13.1(4) Hand Placed Riprap**

27 Hand placed riprap shall be as nearly rectangular as possible, 60 percent shall
 28 have a volume of not less than 1 cubic foot. No stone shall be used which is less
 29 than 6 inches thick, nor which does not extend through the wall.
 30

31 **9-13.1(5) Quarry Spalls**

32 Quarry spalls shall meet the following requirements for grading:
 33

Sieve Size	Percent Passing
8"	100
3"	40 max.
¾"	10 max.

34

1 **9-13.2 Hand Placed Riprap**

2 This section, including title, is deleted in its entirety and replaced with the following:

3
4 **9-13.2 Vacant**

5
6 **9-13.4 Rock for Erosion Control and Scour Protection**

7 The last sentence is revised to read:

8
9 The use of recycled materials and concrete rubble is not permitted for this application.

10
11 **9-13.6 Quarry Spalls**

12 This section, including title, is deleted in its entirety and replaced with the following:

13
14 **9-13.6 Vacant**

15
16 **9-14.AP9**

17 **Section 9-14, Erosion Control and Roadside Planting**
18 **January 5, 2015**

19 **9.14.1 Soil**

20 This section, including title, is revised to read:

21
22 **9-14.1 Topsoil**

23 Topsoil shall not contain any recycled material, foreign materials, or any listed Noxious
24 and Nuisance weeds of any Class designated by authorized State or County officials.
25 Aggregate shall not comprise more than 10% by volume of Topsoil and shall not be
26 greater than two inches in diameter.

27
28 **9-14.1(2) Topsoil Type B**

29 The last sentence of the second paragraph is deleted.

30
31 **9-14.2 Seed**

32 This section is revised to read:

33
34 Seed of the type specified shall be certified in accordance with WAC 16-302. Seed
35 mixes shall be commercially prepared and supplied in sealed containers. The labels
36 shall show:

- 37
38 (1) Common and botanical names of seed
39
40 (2) Lot number
41
42 (3) Net weight
43
44 (4) Pounds of Pure live seed (PLS) in the mix
45
46 (5) Origin of seed
47

1 All seed vendors must have a business license issued by supplier's state or provincial
2 Department of Licensing with a "seed dealer" endorsement.

3
4 **9-14.4(3) Bark or Wood Chips**

5 This section's title is revised to read:

6
7 **Bark or Wood Chip Mulch**

8
9 The first paragraph is revised to read:

10
11 Bark or wood chip mulch shall be derived from fir, pine, or hemlock species. It shall not
12 contain resin, tannin, or other compounds in quantities that would be detrimental to
13 plant life. Sawdust shall not be used as mulch. Mulch produced from finished wood
14 products or construction debris will not be allowed.

15
16 **9-14.4(6) Gypsum**

17 The first sentence is revised to read:

18
19 Gypsum shall consist of Calcium Sulfate ($\text{CaSO}_4 \cdot 2\text{H}_2\text{O}$) in a pelletized or granular
20 form.

21
22 **9-14.4(7) Tackifier**

23 This section is revised to read:

24
25 Tackifiers are used as a tie-down for soil, compost, seed, and/or mulch. Tackifiers shall
26 contain no growth or germination-inhibiting materials and shall not reduce infiltration
27 rates. Tackifiers shall hydrate in water and readily blend with other slurry materials.

28
29 The Contractor shall provide test results documenting the tackifier meets the
30 requirements for Acute Toxicity, Solvents, and Heavy Metals as required in Table 1 in
31 Section 9-14.4(2). The tests shall be performed at the manufacturer's recommended
32 application rate.

33
34 **9-14.4(8) Compost**

35 The second paragraph is revised to read:

36
37 Compost production and quality shall comply with WAC 173-350.

38
39 **9-14.4(8)A Compost Submittal Requirements**

40 Item 2 is revised to read:

- 41
42 2. A copy of the Solid Waste Handling Permit issued to the manufacturer by the
43 Jurisdictional Health Department in accordance with WAC 173-350 (Minimum
44 Functional Standards for Solid Waste Handling).

45
46 **9-14.6(1) Description**

47 Item number 3 in the fourth paragraph is revised to read:

- 48
49 3. Live pole cuttings shall have a diameter between 2 inches and 3.5 inches. Live
50 poles shall have no more than three branches which must be located at the top

1 end of the pole and those branches shall be pruned back to the first bud from the
2 main stem.

3

4 **9-14.6(2) Quality**

5 The second and third paragraphs in this section are revised to read:

6

7 All plant material shall comply with State and Federal laws with respect to inspection
8 for plant diseases and insect infestation. Plants must meet Washington State
9 Department of Agriculture plant quarantines and have a certificate of inspection. Plants
10 originating in Canada must be accompanied by a phytosanitary certificate stating the
11 plants meet USDA health requirements.

12

13 All plant material shall be purchased from a nursery licensed to sell plants in their state
14 or province.

15

16 **9-15.AP9**

17 **Section 9-15, Irrigation System**

18 **August 4, 2014**

19 **9-15.18 Detectable Marking Tape**

20 In the second paragraph, the table is supplemented with the following new row:

21

Non-Potable Water	Purple
-------------------	--------

22

23

24 **9-16.AP9**

25 **Section 9-16, Fence and Guardrail**

26 **August 4, 2014**

27 **9-16.2(1)B Wood Fence Posts and Braces**

28 In the table, the row beginning with "ACA" is deleted.

29

30 **9-29.AP9**

31 **Section 9-29, Illumination, Signal, Electrical**

32 **April 6, 2015**

33 **9-29.1 Conduit, Innerduct, and Outerduct**

34 This section is supplemented with the following new subsection:

35

36 **9-29.1(9) Repair**

37 Manufacturer repair kits shall be used for field repair of existing conduit, innerduct and
38 outerduct. The conduit repair kit shall be manufactured specifically for the repair of
39 existing damaged conduit, inner duct and outer duct. The repair kit shall be
40 prepackaged and include the split conduit and split couplings necessary to restore the
41 damaged conduit to the original inside dimensions including a water and air tight seal.

42

1 **9-29.2(1)B Heavy Duty Junction Boxes**

2 The second paragraph is revised to read:

3
4 The Heavy-Duty Junction Box steel frame, lid support and lid fabricated from steel
5 plate and shapes shall be painted with a shop applied, inorganic zinc primer in
6 accordance with Section 6-07.3. Ductile iron and gray iron castings shall not be
7 painted.

8
9 The following new paragraph is inserted after the second paragraph:

10
11 The concrete used in Heavy-Duty Junction Boxes shall have a minimum compressive
12 strength of 4,000 psi.

13
14 In the fourth paragraph (after the preceding Amendment is applied), the table is revised to
15 read:

16

Materials	Requirement
Concrete	Section 6-02
Reinforcing Steel	Section 9-07
Lid	ASTM A 786 diamond plate steel, rolled from plate complying with ASTM A 572, grade 50 or ASTM A 588, and having a min. CVN toughness of 20 ft-lb at 40 degrees F. Or Ductile iron casting meeting Section 9-05.15
Frame and stiffener plates	ASTM A 572 grade 50 or ASTM A 588, both with min. CVN toughness of 20 ft-lb at 40 degrees F Or Gray iron casting meeting Section 9-05.15
Anchors (studs)	Section 9-06.15
Threaded Anchors for Gray Iron Frame	ASTM F1554 grade 55 Headed Anchor Requirements
Bolts, Studs, Nuts, Washers	ASTM F 593 or A 193, Type 304 or 316, or Stainless steel grade 302, 304, or 316 in accordance with approved shop drawings
Hinges and Locking and Latching Mechanism and associated Hardware and Bolts	In accordance with approved shop drawings
Safety Bars	In accordance with approved shop drawings

17
18 The last paragraph is revised to read:

19
20 The bearing seat and lid perimeter shall be free from burrs, dirt, and other foreign
21 debris that would prevent solid seating. Bolts and nuts shall be liberally coated with
22 anti-seize compound. Bolts shall be installed snug tight. The bearing seat and lid
23 perimeter shall be machined to allow a minimum of 75 percent of the bearing areas to
24 be seated with a tolerance of 0.0 to 0.005 inches measured with a feeler gage. The
25 bearing area percentage will be measured for each side of the lid as it bears on the
26 frame.

1
2 **9-29.2(2) Standard Duty and Heavy-Duty Cable Vaults and Pull Boxes**

3 This section's title is revised to read:

4
5 **Small Cable Vaults, Standard Duty Cable Vaults, Heavy-Duty Cable Vaults,**
6 **Standard Duty Pull Boxes, and Heavy-Duty Pull Boxes**
7

8 In the first paragraph, the first sentence is revised to read:

9
10 Small, Standard Duty and Heavy-Duty Cable Vaults and Standard Duty and Heavy-
11 Duty Pull Boxes shall be constructed as a concrete box and as a concrete lid.
12

13 **9-29.2(2)A Standard Duty Cable Vaults and Pull Boxes**

14 This section's title is revised to read:

15
16 **Small Cable Vaults, Standard Duty Cable Vaults, and Standard Duty Pull Boxes**
17

18 The first paragraph is revised to read:

19
20 Small and Standard Duty Cable Vaults and Standard Duty Pull boxes shall be concrete
21 and have a minimum load rating of 22,500 pounds and be tested in accordance with
22 Section 9-29.2(1)C for concrete Standard Duty Junction Boxes.
23

24 In the second paragraph, the first sentence is revised to read:

25
26 Concrete for Small and Standard Duty Cable Vaults and Standard Duty Pull Boxes
27 shall have a minimum compressive strength of 4,000 psi.
28

29 In the third paragraph, the first sentence is revised to read:

30
31 All Small and Standard Duty Cable Vaults and Standard Duty Pull Boxes placed in
32 sidewalks, walkways, and shared-use paths shall have slip-resistant surfaces.
33

34 The fourth paragraph (up until the colon) is revised to read:

35
36 Materials for Small and Standard Duty Cable Vaults and Standard Duty Pull Boxes
37 shall conform to the following:
38

39 **9-29.3 Fiber Optic Cable, Electrical Conductors, and Cable**

40 This section is supplemented with the following new subsection:

41
42 **9-29.3(3) Wire Marking Sleeves**

43 Wire marking sleeves shall be full-circle in design, non-adhesive, printable using an
44 indelible ink and shall fit snugly on the wire or cable. Marking sleeves shall be made
45 from a PVC or polyolefin, and provide permanent identification for wires and cables.
46

47 **9-29.3(2)A4 Location Wire**

48 This section is revised to read:
49

1 Location wire shall be steel core copper clad minimum size AWG 14 insulated
2 conductor. The insulation shall be orange High Molecular Weight High Density
3 Polyethylene (HMHDPE).
4

5 **9-29.16 Vehicular Signal Heads, Displays, and Housing**

6 The last sentence of the last paragraph is revised to read:
7

8 A 1-inch-wide strip of yellow retro-reflective, type IV prismatic sheeting, conforming to
9 the requirements of Section 9-28.12, shall be applied around the perimeter of each
10 backplate with the exception of installations where all sections of the display will be
11 dark as part of normal operation such as ramp meters, hawk signals and tunnels.
12

13 **9-31.AP9**

14 **Section 9-31, Elastomeric Bearing Pads** 15 **August 4, 2014**

16 This section's title is revised to read:
17

18 **Elastomeric Pads**

19 **9-31.1 Requirements**

20 In the first paragraph, the word "bearing" is deleted from the first sentence.
21
22

23 In the first sentence of the second paragraph, the word "bearing" is deleted and replaced
24 with "elastomeric".
25

26 In the last sentence of the second paragraph, the word "Bearing" is deleted and replaced
27 with "Elastomeric".
28

29 In the third paragraph, the word "bearing" is deleted and replaced with the word
30 "elastomeric".
31

32 **9-32.AP9**

33 **Section 9-32, Mailbox Support** 34 **August 4, 2014**

35 **9-32.7 Type 2 Mailbox Support**

36 The first sentence is revised to read:
37

38 Type 2 mailbox supports shall be 2-inch 14-gage steel tube and shall meet the NCHRP
39 350 or the Manual for Assessing Safety Hardware (MASH) crash test criteria.
40

1 **9-34.AP9**

2 **Section 9-34, Pavement Marking Material**
3 **January 5, 2015**

4 **9-34.2 Paint**

5 The second paragraph is revised to read:

6

7 Blue and black paint shall comply with the requirements of yellow paint in Section 9-
8 34.2(4) and Section 9-34.2(5), with the exception that blue and black paints do not
9 need to meet the requirements for titanium dioxide, directional reflectance, and
10 contrast ratio.

11

12 **9-34.4 Glass Beads for Pavement Marking Materials**

13 In the third paragraph, the table titled "Metal Concentration Limits" is revised to read:

14

Metal Concentration Limits		
Element	Test Method	Max. Parts Per Million (ppm)
Arsenic	EPA 3052 SW-846 6010C	10.0
Barium	EPA 3052 SW-846 6010C	100.0
Cadmium	EPA 3052 SW-846 6010C	1.0
Chromium	EPA 3052 SW-846 6010C	5.0
Lead	EPA 3052 SW-846 6010C	50.0
Silver	EPA 3052 SW-846 6010C	5.0
Mercury	EPA 3052 SW-846 7471B	4.0

15

16

17 **9-34.5 Temporary Pavement Marking Tape**

18 This section is revised to read:

19

20 Biodegradable tape with paper backing is not allowed.

21

22 This section is supplemented with the following new sub-sections:

23

24 **9-34.5(1) Temporary Pavement Marking Tape – Short Duration**

25 Temporary pavement marking tape for short duration shall conform to ASTM D4592
26 Type II except that black tape, black mask tape and the black portion of the contrast
27 removable tape, shall be non-reflective.

28

29 **9-34.5(2) Temporary Pavement Marking Tape – Long Duration**

30 Temporary pavement marking tape for long duration shall conform to ASTM D4592
31 Type I. Temporary pavement marking tape for long duration, except for black tape,
32 shall have a minimum initial coefficient of retroreflective luminance of 200 mcd*m⁻²*lx⁻¹
33 when measured in accordance with ASTM E 2832 or ASTM E 2177. Black tape, black
34 mask tape and the black portion of the contrast removable tape, shall be non-reflective.

35

36 **9-34.6 Temporary Raised Pavement Markers**

37 This section's title is revised to read:

38

39 **Temporary Flexible Raised Pavement Markers**

40

1 The second paragraph is deleted.

2

3 **9-35.AP9**

4 **Section 9-35, Temporary Traffic Control Materials**

5 **August 4, 2014**

6 **9-35.0 General Requirements**

7 The following item is deleted from the list of temporary traffic control materials:

8

9 Barrier Drums

10

11 The last sentence of the second paragraph is revised to read:

12

13 Certification for crashworthiness according to NCHRP 350 or the Manual for Assessing
14 Safety Hardware (MASH) will be required as described in Section 1-10.2(3).

15

16 **9-35.2 Construction Signs**

17 The first sentence is revised to read:

18

19 Construction signs shall conform to the requirements of the MUTCD and shall meet the
20 requirements of NCHRP Report 350 for Category 2 devices or MASH.

21

22 **9-35.7 Traffic Safety Drums**

23 The third paragraph is revised to read:

24

25 Drums and light units shall meet the crashworthiness requirements of NCHRP 350 or
26 MASH as described in Section 1-10.2(3).

27

28 **9-35.8 Barrier Drums**

29 This section including title is deleted in its entirety and replaced with the following:

30

31 **9-35.8 Vacant**

32

33 **9-35.12 Transportable Attenuator**

34 In the first paragraph, the fourth sentence is revised to read:

35

36 The Contractor shall provide certification that the transportable attenuator complies
37 with NCHRP 350 Test level 3 or MASH Test Level 3 requirements.

38

39 **9-35.13 Tall Channelizing Devices**

40 In the sixth paragraph, the last sentence is revised to read:

41

42 The method of attachment must ensure that the light does not separate from the
43 device upon impact and light units shall meet the crashworthiness requirements of
44 NCHRP 350 or MASH as described in Section 1-10.2(3).

45

46

APPENDIX B
STANDARD PLANS

STANDARD PLANS AND DETAILS

Note: Some Standard Plans needed for this project are attached for your convenience and listed below, but the Standard Plans required for this project are not limited to those listed.

WSDOT

A-10.10-00	Survey Stakes
A-10.30-00	Monument Case and Cover
A-40.10-02	Cement Concrete Pavement Joints
F-10.12-03	Cement Concrete Curbs
F-10.18-00	Roundabout Cement Concrete Curbs
F-10.62-02	Precast Sloped Mountable Curb
F-40.14-02	Combination Curb Ramps
F-40.15-02	Perpendicular Curb Ramps
F-40.16-02	Single Direction Curb Ramp
F-45.10-01	Detectable Warning Surface
F-80.10-03	Cement Concrete Driveway Entrance Types 1,2,3 & 4
I-30.15-02	Silt Fence
I-40.20-00	Storm Drain Inlet Protection
J-3c	Service Cabinet Type D
J-28.30-03	Steel Light Standard Foundation Types A & B (2 sheets)
J-40.10-03	Locking Lid Standard Duty Junction Box Types 1 and 2 (2 sheets)
K-70.20-00	Temporary Channelization
K-80.10-00	Class A Construction Signing Installation
K-80.20-00	Type 3 Barricade
K-80.30-00	Alternative Temporary Conc. Barrier (F-Shape)
M-15.10-01	Crosswalk Layout
M-20.10-02	Longitudinal Marking Patterns
M-24.40-01	Symbol Markings Traffic Arrows for Low Speed Roadways
M-24.50-00	Roundabout Traffic Arrows
M-24.60-04	Symbol Markings Miscellaneous

Snohomish County Standard Plans

7-110	Triple Fours Crosswalk
-------	------------------------

City of Marysville Standard Plans

3-805-001	Post Mounting Detail for Street Names and Stop Sign
-----------	-----------------------------------------------------

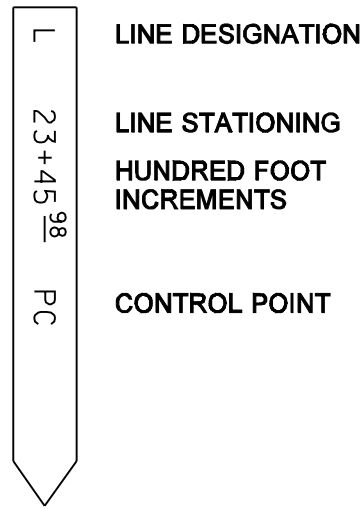

ALIGNMENT STAKE
STAKE EVERY 100 FEET ON TANGENTS,
EVERY 25 FEET ON CURVES

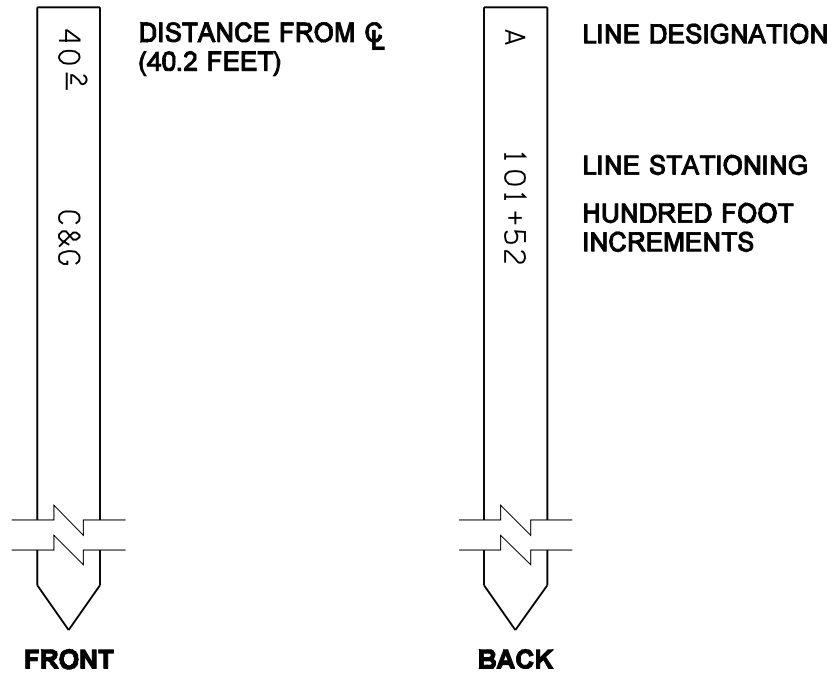

CLEARING/GRUBBING (C&G) LATH
STAKE AT EACH FULL STATION,
100 FEET ON TANGENTS,
EVERY 25 FEET ON CURVES.
NO HUB NECESSARY.

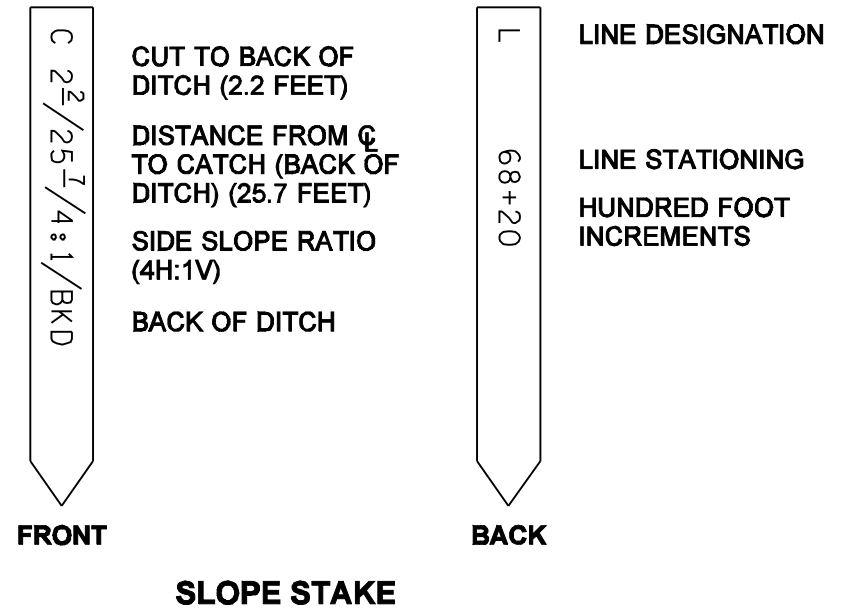

SLOPE STAKE

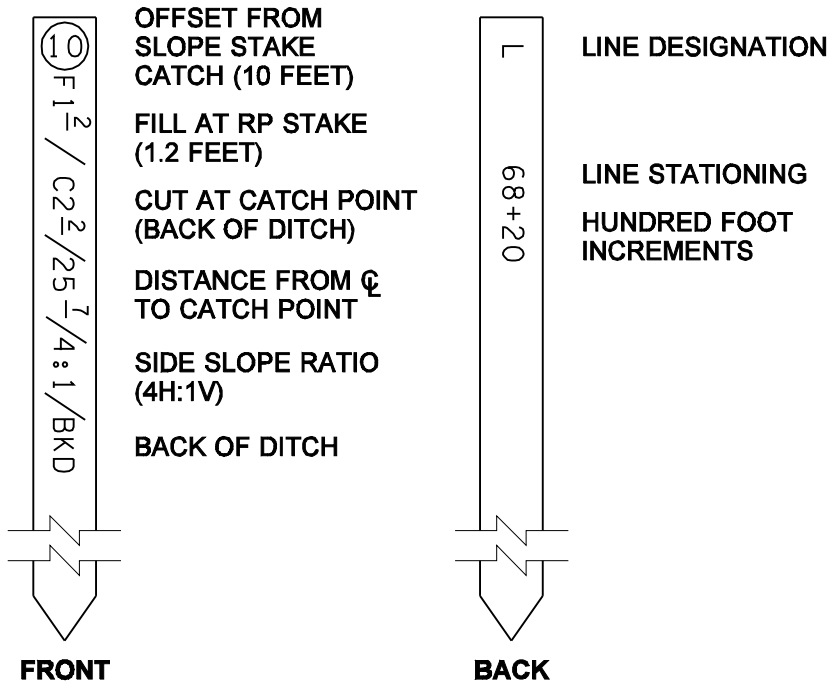

LATH FOR SLOPE REFERENCES

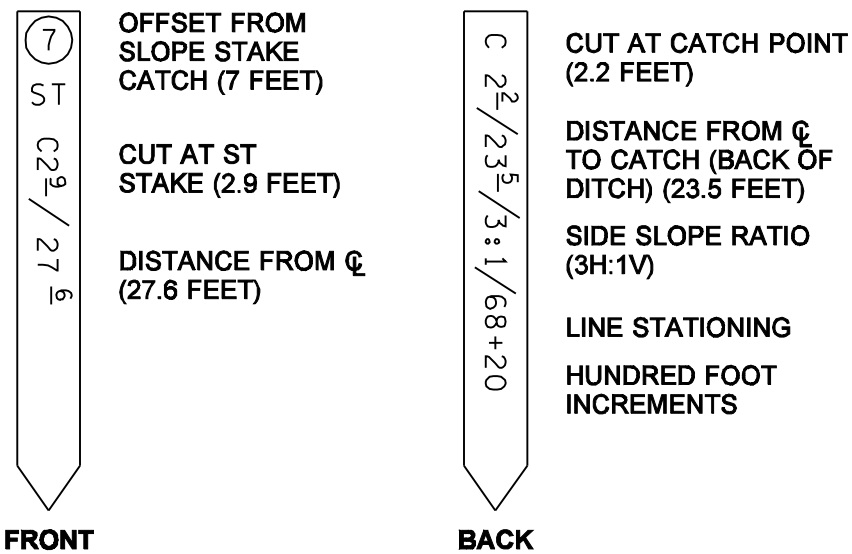

**SLOPE TREATMENT (ST) STAKE
FOR CUT SECTIONS**

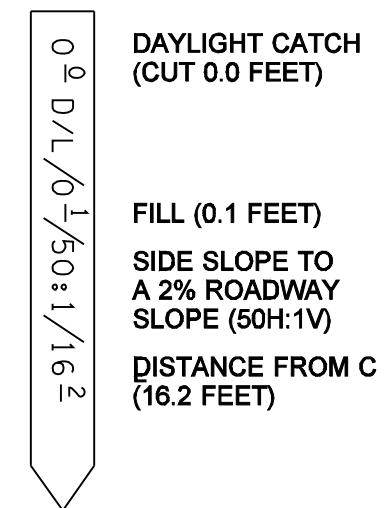

DAYLIGHT (D/L) STAKE

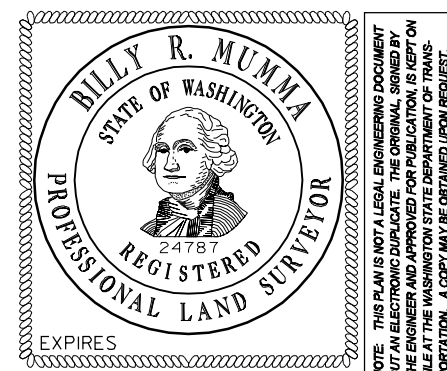

NOTE: THIS PLAN IS NOT A LEGAL ENGINEERING DOCUMENT BUT AN ELECTRONIC DRAWING. THE ORIGINAL, SIGNED BY THE ENGINEER AND APPROVED FOR PUBLICATION, IS KEPT ON FILE AT THE WASHINGTON STATE DEPARTMENT OF TRANSPORTATION. A COPY MAY BE OBTAINED UPON REQUEST.

SURVEY STAKES

STANDARD PLAN A-10.10-00

SHEET 1 OF 2 SHEETS

APPROVED FOR PUBLICATION

Pasco Bakotich III 08-07-07

STATE DESIGN ENGINEER DATE

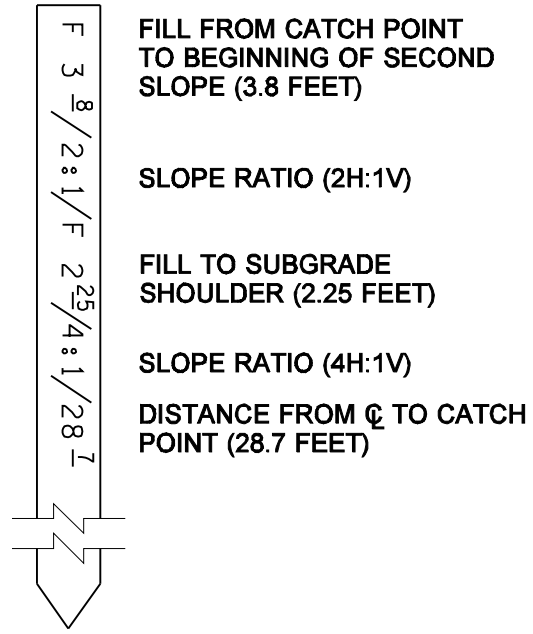

FILL FROM CATCH POINT TO BEGINNING OF SECOND SLOPE (3.8 FEET)
 SLOPE RATIO (2H:1V)
 FILL TO SUBGRADE SHOULDER (2.25 FEET)
 SLOPE RATIO (4H:1V)
 DISTANCE FROM ϕ TO CATCH POINT (28.7 FEET)

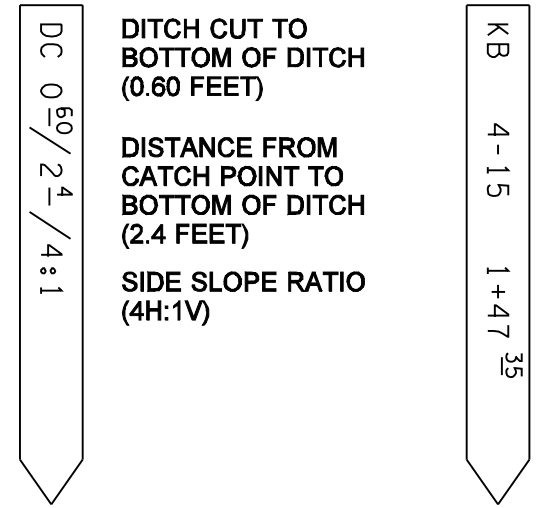

DITCH CUT TO BOTTOM OF DITCH (0.60 FEET)
 DISTANCE FROM CATCH POINT TO BOTTOM OF DITCH (2.4 FEET)
 SIDE SLOPE RATIO (4H:1V)
 STRUCTURE NOTE REFERENCE
 PLAN SHEET NUMBER (4)
 STRUCTURE NOTE NUMBER (15)
 DITCH SECTION ALIGNMENT STATIONING

FRONT BACK
 STAKE FOR DITCH CONSTRUCTION

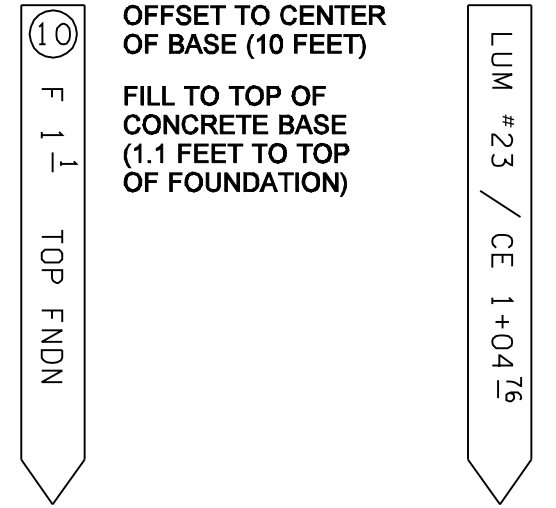

OFFSET TO CENTER OF BASE (10 FEET)
 FILL TO TOP OF CONCRETE BASE (1.1 FEET TO TOP OF FOUNDATION)
 LUMINAIRE NUMBER (23)
 LINE DESIGNATION AND STATIONING
 HUNDRED FOOT INCREMENTS

FRONT BACK
 STAKE FOR FOUNDATION OF LUMINAIRES, SIGNALS OR SIGN STRUCTURES

COMPOUND SLOPE LATH

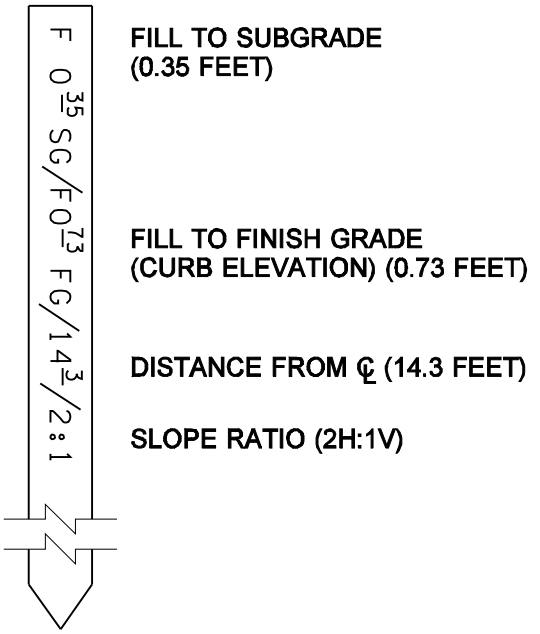

FILL TO SUBGRADE (0.35 FEET)
 FILL TO FINISH GRADE (CURB ELEVATION) (0.73 FEET)
 DISTANCE FROM ϕ (14.3 FEET)
 SLOPE RATIO (2H:1V)

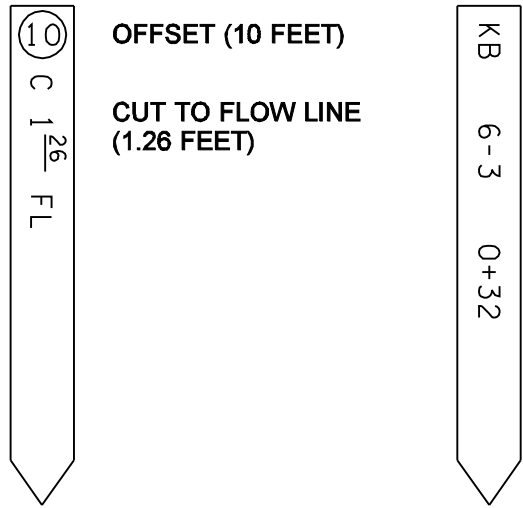

OFFSET (10 FEET)
 CUT TO FLOW LINE (1.26 FEET)
 STRUCTURE NOTE REFERENCE
 PLAN SHEET NUMBER (6)
 STRUCTURE NOTE NUMBER (3)
 DRAINAGE ALIGNMENT STATIONING
 25' INCREMENTS

FRONT BACK
 STAKE FOR DRAINAGE

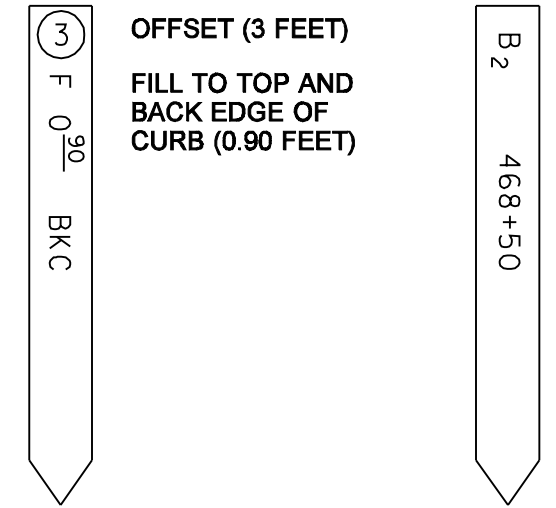

OFFSET (3 FEET)
 FILL TO TOP AND BACK EDGE OF CURB (0.90 FEET)
 LINE DESIGNATION
 LINE STATIONING
 HUNDRED FOOT INCREMENTS

FRONT BACK
 STAKE FOR CURB/GUTTER

SLOPE LATH FOR CURB SECTION

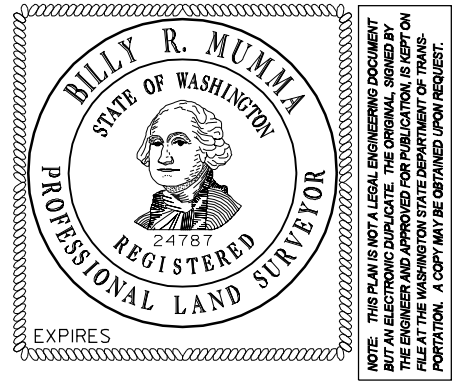

SURVEY STAKES

STANDARD PLAN A-10.10-00

SHEET 2 OF 2 SHEETS

APPROVED FOR PUBLICATION
Pasco Bakotich III 08-07-07
 STATE DESIGN ENGINEER DATE
 Washington State Department of Transportation

DRAWN BY: FERN LIDDELL

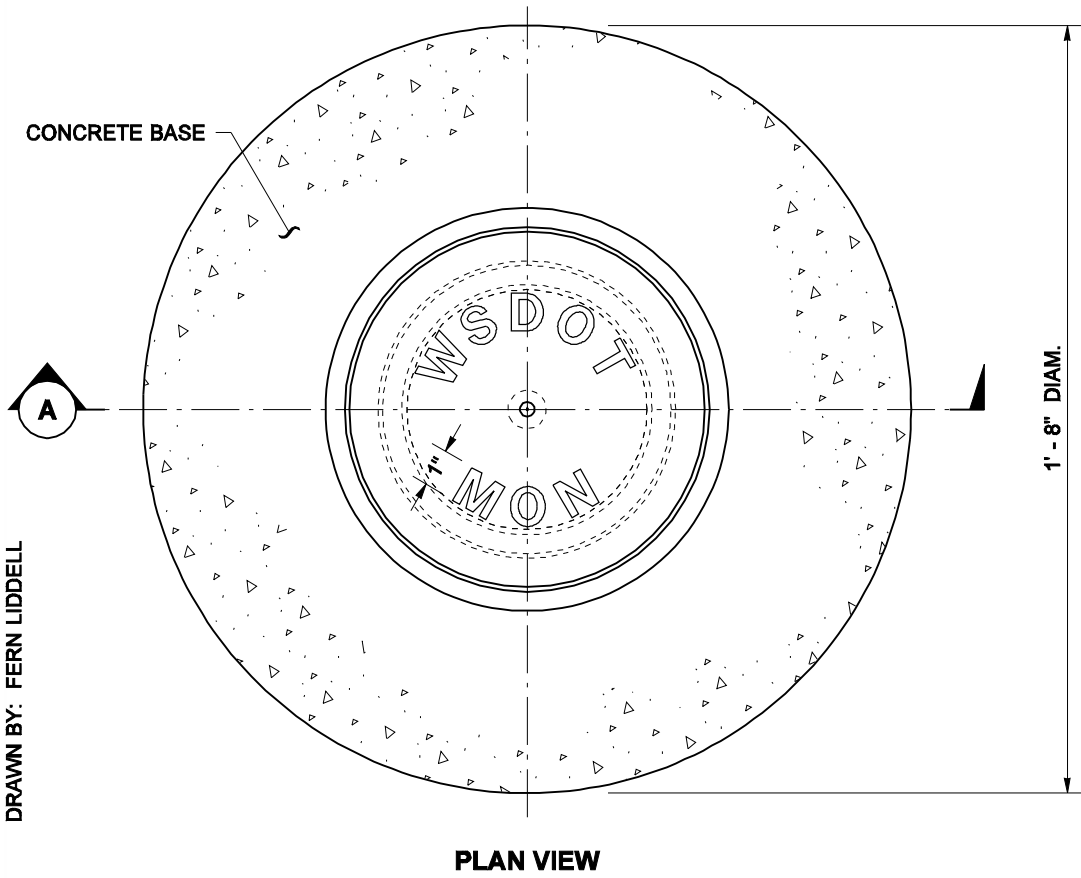

PLAN VIEW

RISER RING DIMENSIONS			
A (SIZE)	1 1/2"	2"	3"

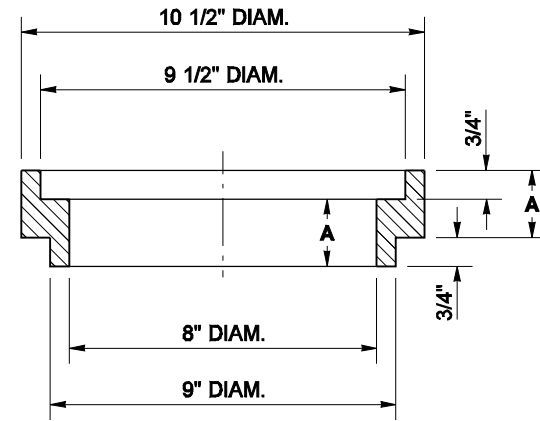

**SECTION
RISER RING**

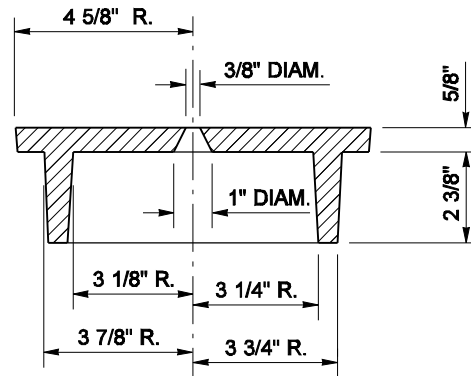

**SECTION
COVER**

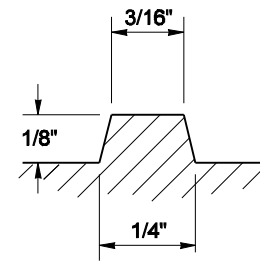

SECTION OF LETTER

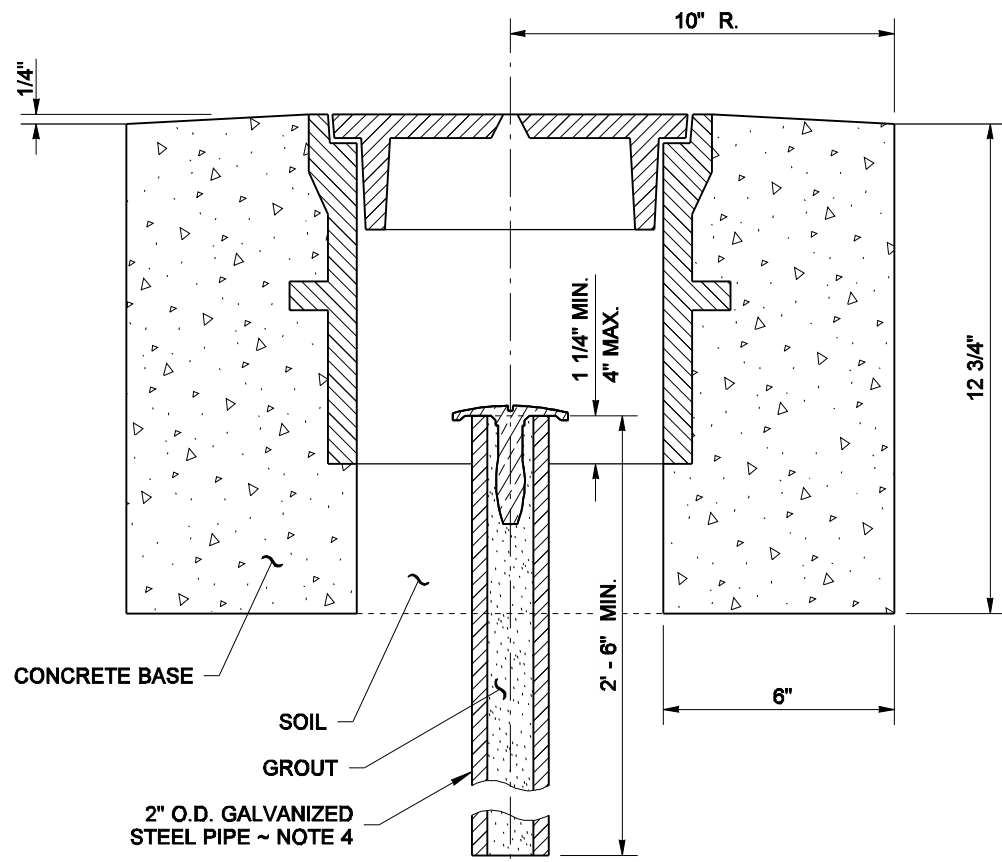

**SECTION A
INSTALLATION**

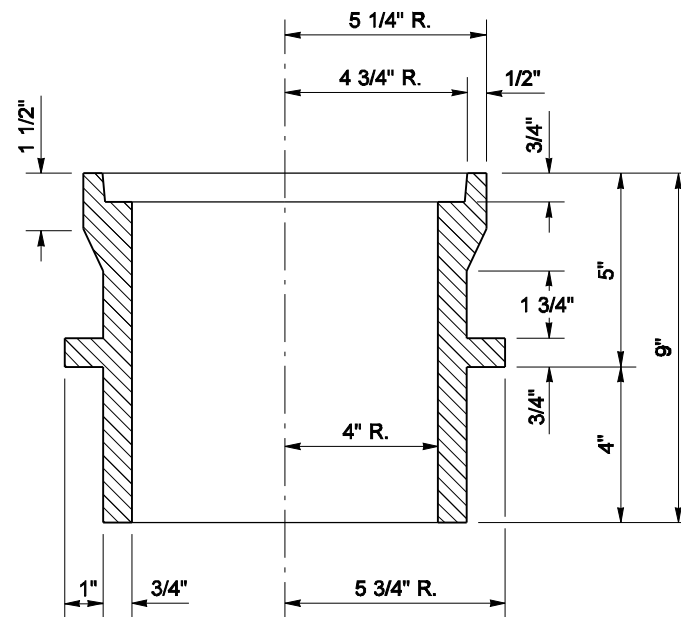

**SECTION
CASE**

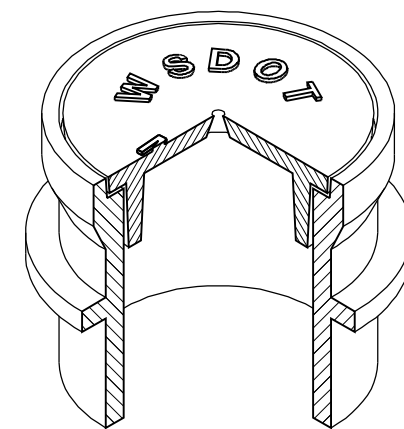

ISOMETRIC

NOTES

1. Dimensions may vary according to manufacturer.
2. Base to be placed on a well compacted foundation.
3. Monument case to be installed by contractor.
4. See Standard Plan A-10.20 for Monument (brass disc) type to place in 2" O.D. galvanized pipe.

APPROXIMATE WEIGHTS

CASE	60 LBS
COVER	19 LBS
TOTAL	79 LBS

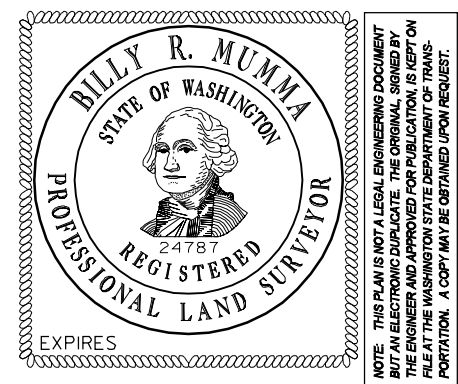

**MONUMENT CASE
AND COVER
STANDARD PLAN A-10.30-00**

SHEET 1 OF 1 SHEET

APPROVED FOR PUBLICATION

Pasco Bakotich III 10-05-07

STATE DESIGN ENGINEER

DATE



DRAWN BY: FERN LIDDELL

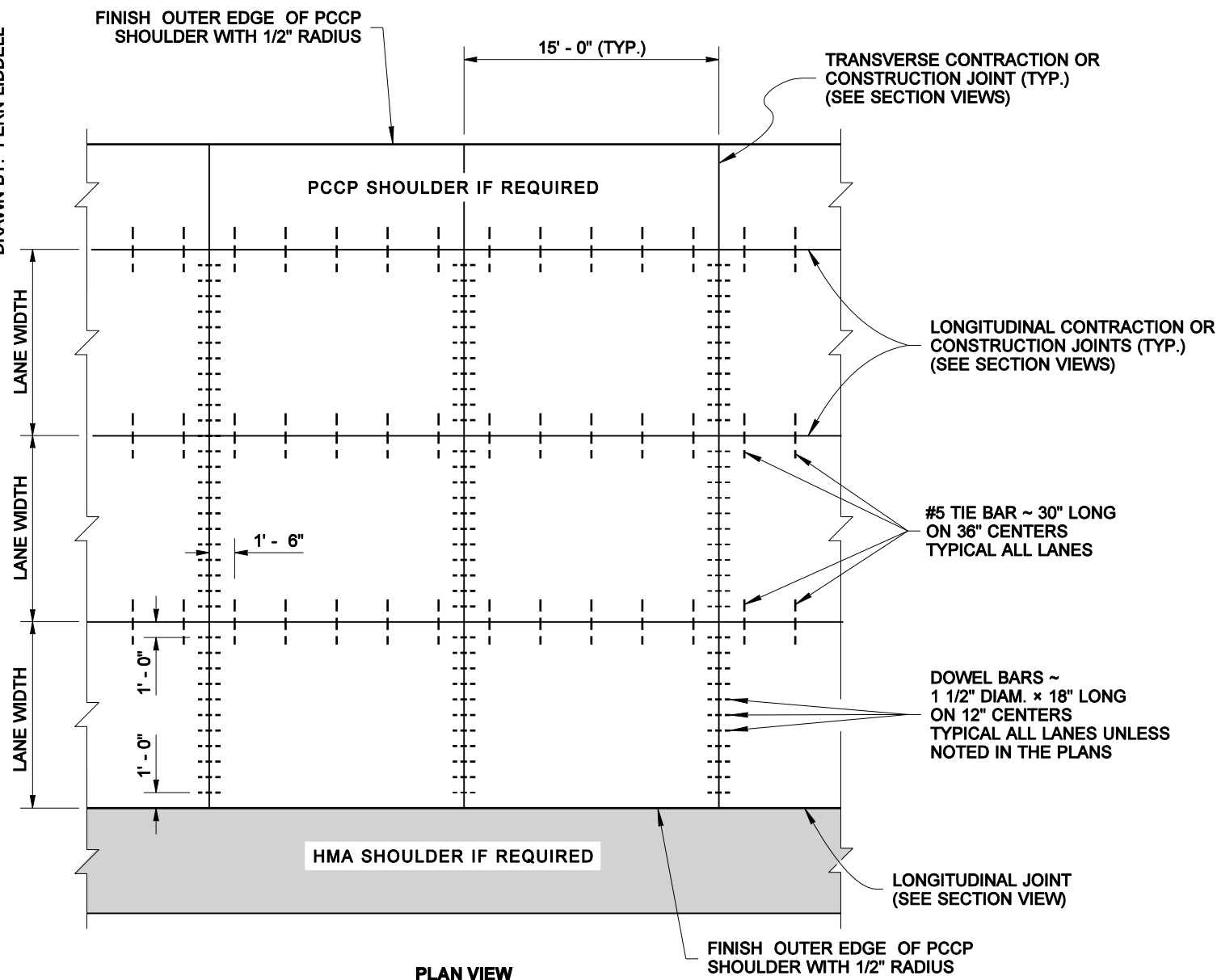

PLAN VIEW

SLAB THICKNESS (D)	A
12"	5"
D	D/2 - 1"

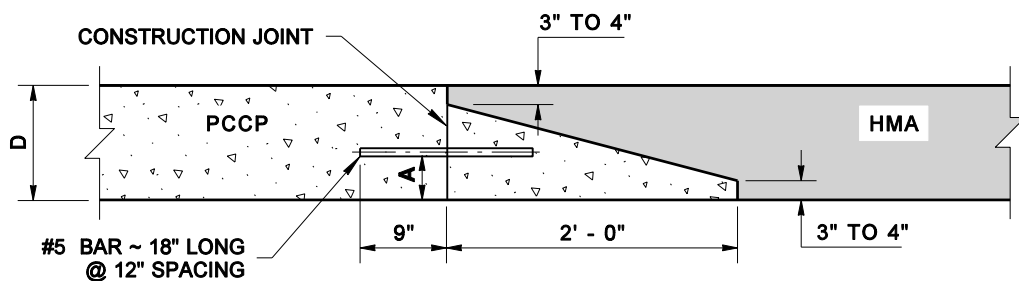

ELEVATION VIEW

HMA TRANSITION DETAIL

DEPTH OF PCCP (D)	A
12"	15"
D	1.25 x D

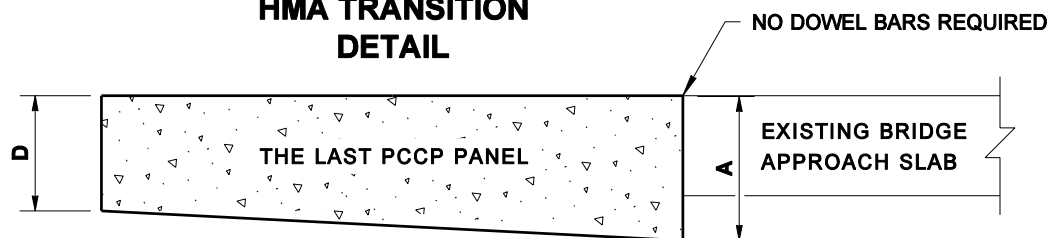

ELEVATION VIEW

EXISTING APPROACH SLAB TRANSITION DETAIL

USE ON GRANULAR BASES ONLY
NO TAPER REQUIRED ON ASPHALT BASES

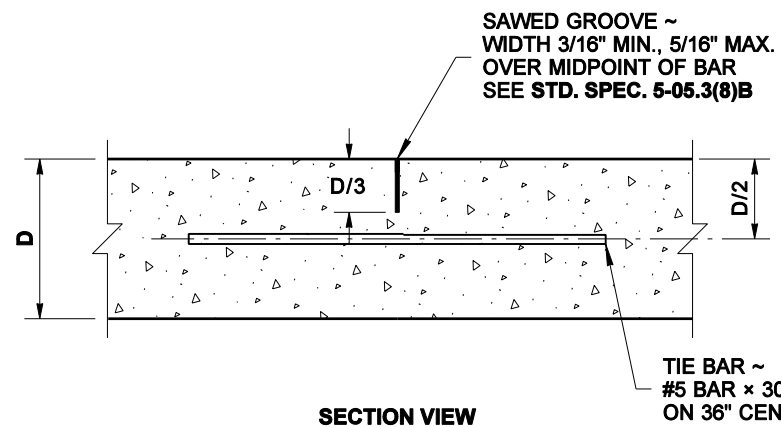

SECTION VIEW

LONGITUDINAL CONTRACTION JOINT

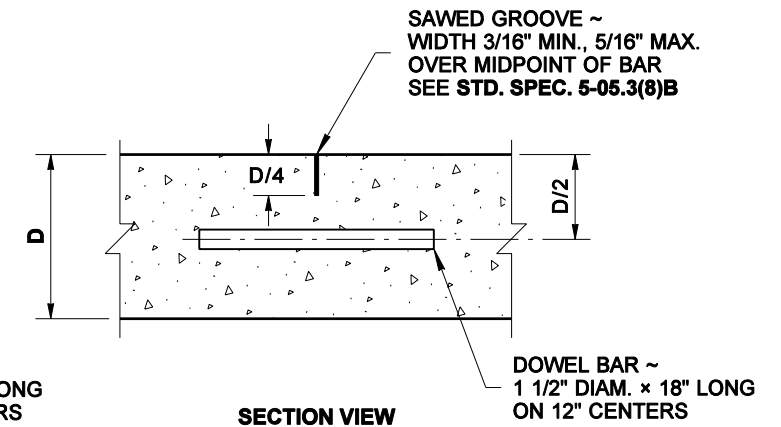

SECTION VIEW

TRANSVERSE CONTRACTION JOINT

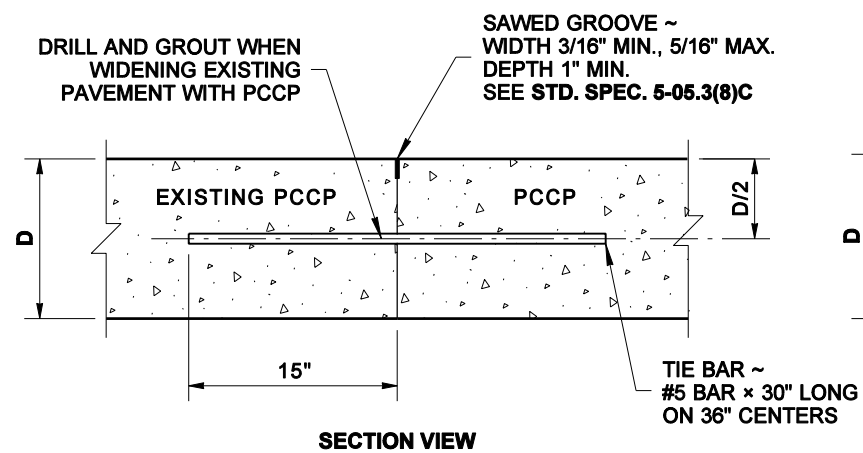

SECTION VIEW

PCCP TO PCCP LONGITUDINAL CONSTRUCTION JOINT

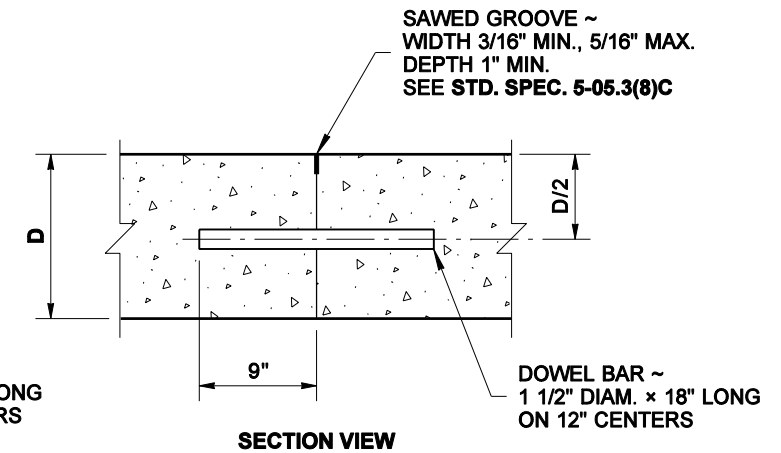

SECTION VIEW

TRANSVERSE CONSTRUCTION JOINT

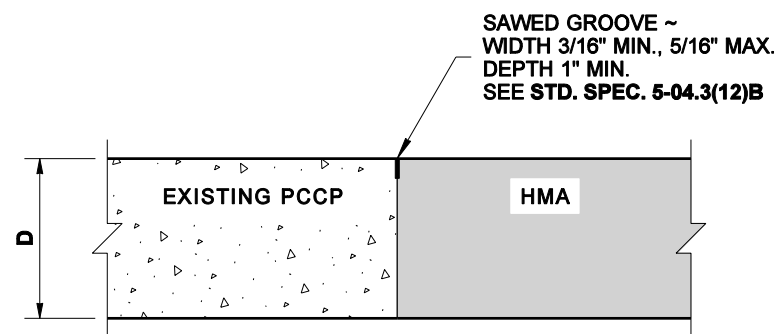

SECTION VIEW

PCCP TO HMA LONGITUDINAL JOINT



NOTE: THIS PLAN IS NOT A LEGAL ENGINEERING DOCUMENT UNLESS IT IS SIGNED BY THE ENGINEER AND APPROVED BY THE BOARD OF ENGINEERS. THE ENGINEER'S SIGNATURE AND SEAL MUST BE FILED AT THE WASHINGTON STATE DEPARTMENT OF TRANSPORTATION. A COPY MAY BE OBTAINED UPON REQUEST.

CEMENT CONCRETE PAVEMENT JOINTS
STANDARD PLAN A-40.10-02

SHEET 1 OF 1 SHEET

APPROVED FOR PUBLICATION

Pasco Bakotich III 06-02-11
STATE DESIGN ENGINEER DATE



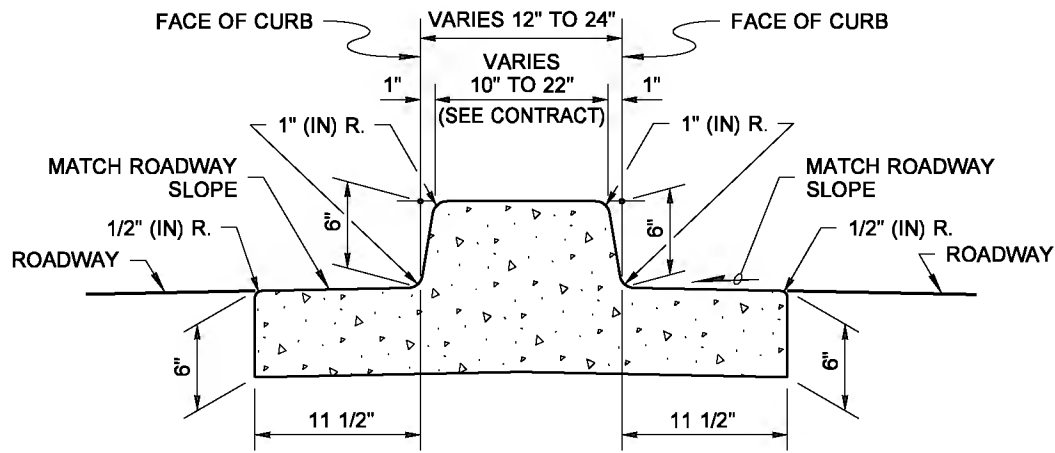

DUAL-FACED CEMENT CONCRETE TRAFFIC CURB AND GUTTER

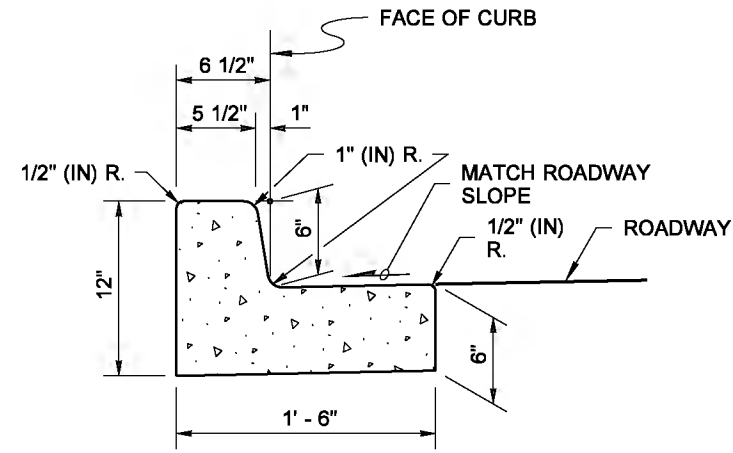

CEMENT CONCRETE TRAFFIC CURB AND GUTTER

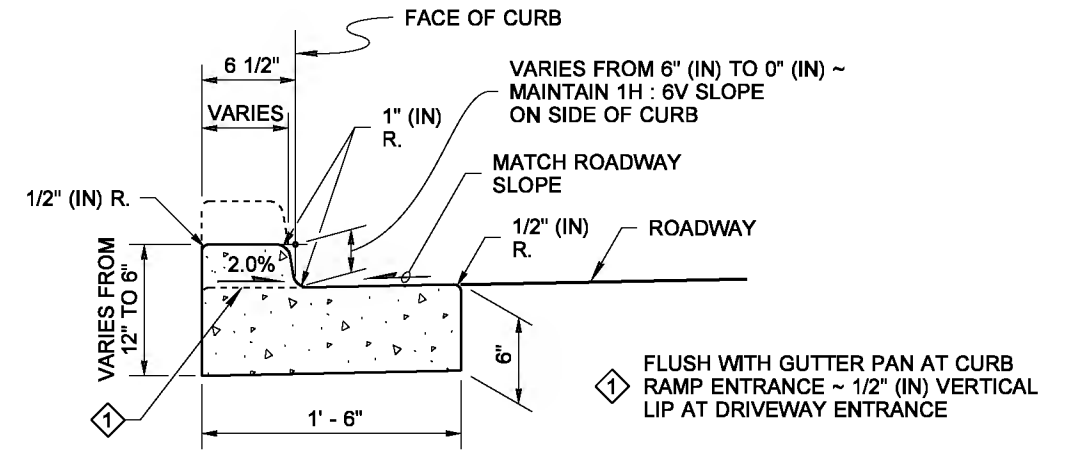

DEPRESSED CURB SECTION AT CURB RAMPS AND DRIVEWAY ENTRANCES

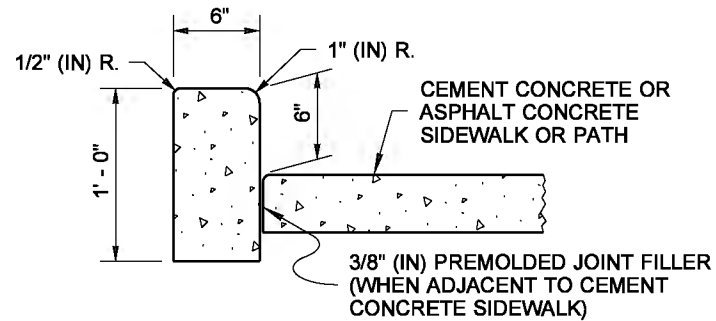

CEMENT CONCRETE PEDESTRIAN CURB

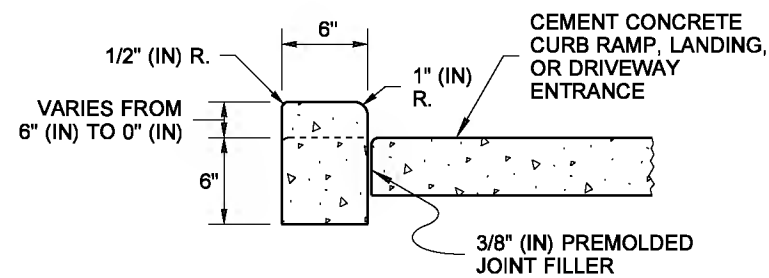

CEMENT CONCRETE PEDESTRIAN CURB AT CURB RAMPS, LANDINGS, AND DRIVEWAY ENTRANCES

NOTE

1. See **Standard Plan F-30.10** for Curb Expansion and Contraction Joint spacing and see **Standard Specification Sections 8-04 and 9-04** for additional requirements.

DRAWN BY: FERN LIDDELL

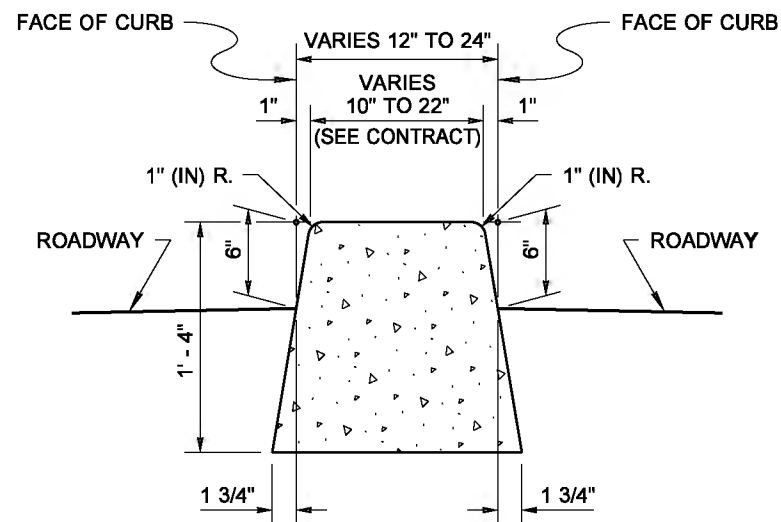

DUAL-FACED CEMENT CONCRETE TRAFFIC CURB

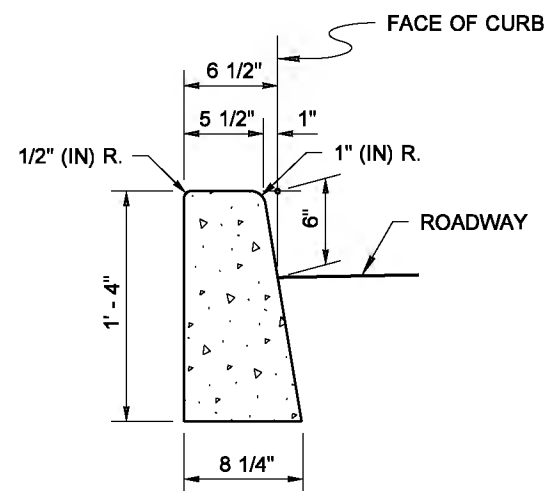

CEMENT CONCRETE TRAFFIC CURB

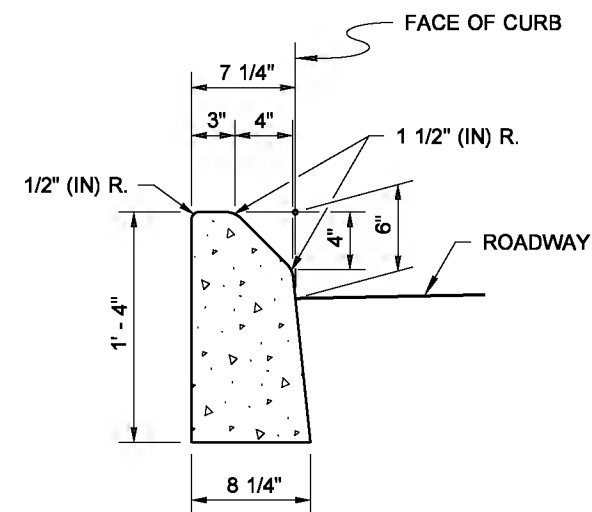

MOUNTABLE CEMENT CONCRETE TRAFFIC CURB

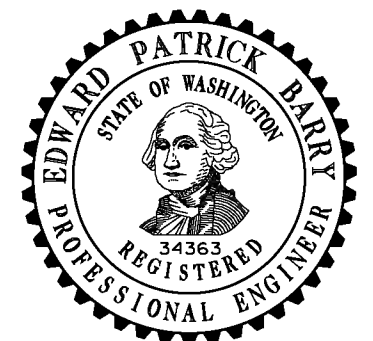

**CEMENT CONCRETE CURBS
STANDARD PLAN F-10.12-03**

SHEET 1 OF 1 SHEET

APPROVED FOR PUBLICATION

STATE DESIGN ENGINEER
Washington State Department of Transportation

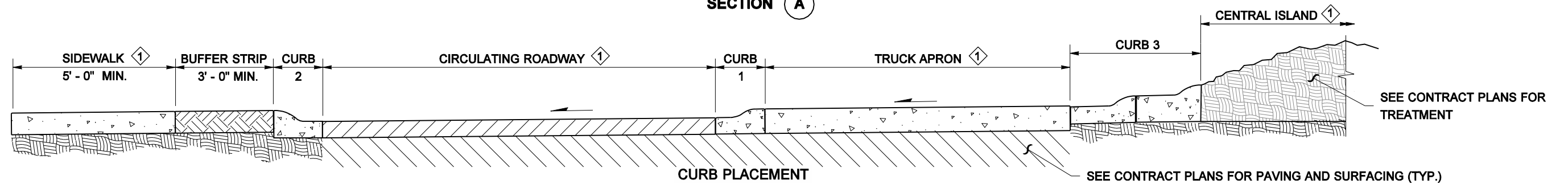
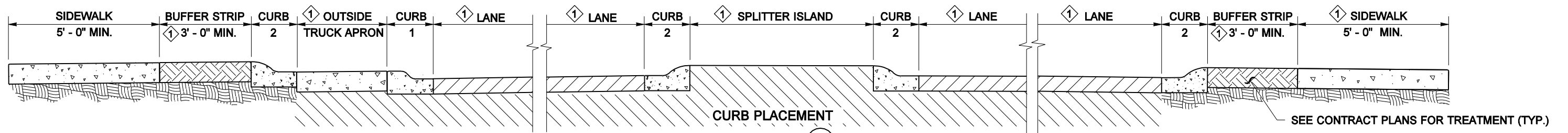

(ROUNDBOUT CONFIGURATION WILL VARY
DEPENDING ON CONTRACT PLANS)

NOTES

1. See **Standard Plan F-30.10** for Curb Expansion and Contraction Joint spacing.

LEGEND

① WIDTH VARIES ~ SEE CONTRACT PLANS

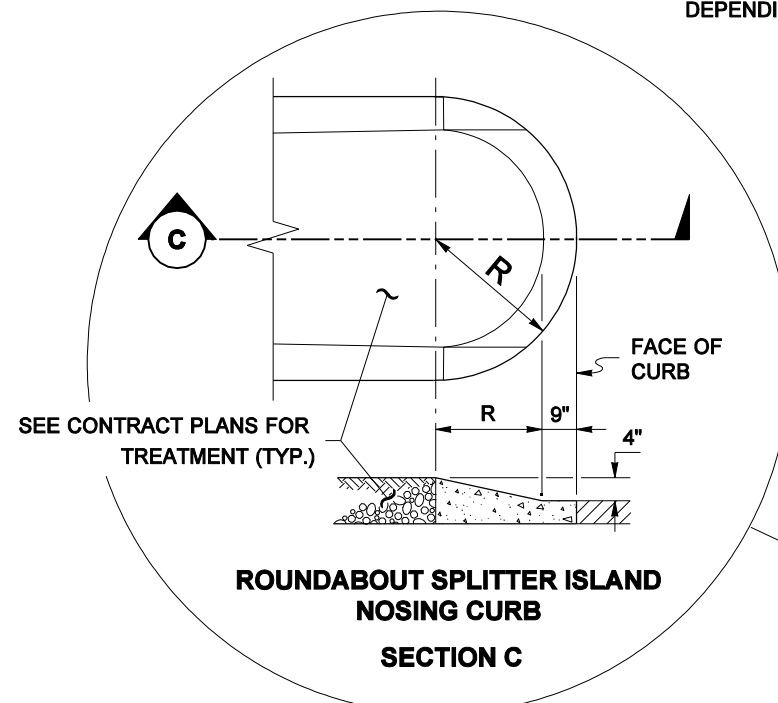
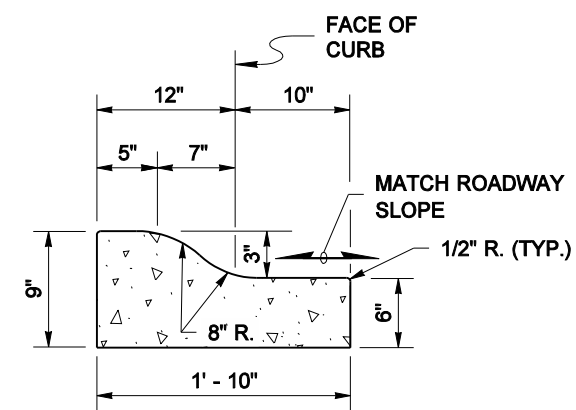

DETAIL

(SEE CONTRACT PLANS FOR R)

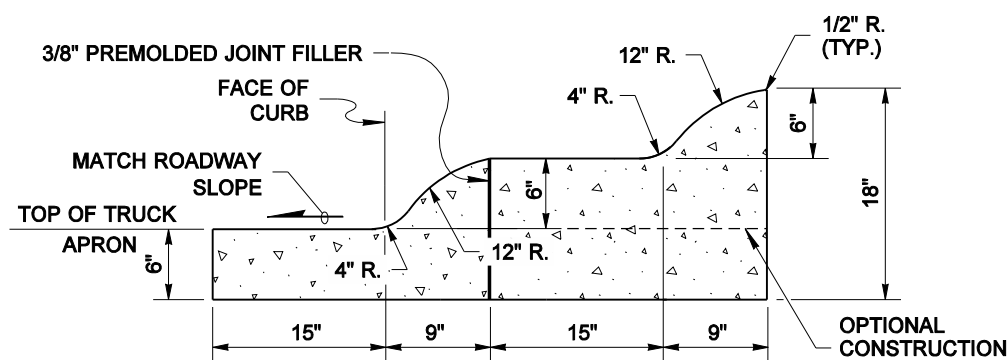
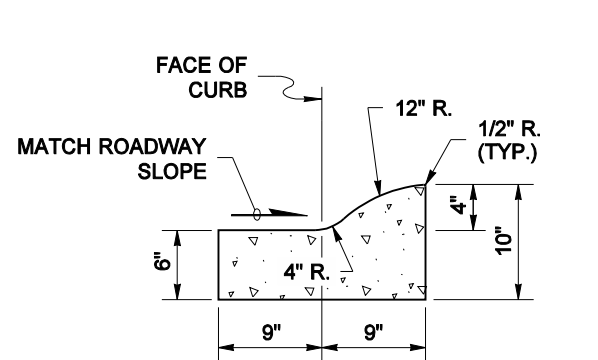
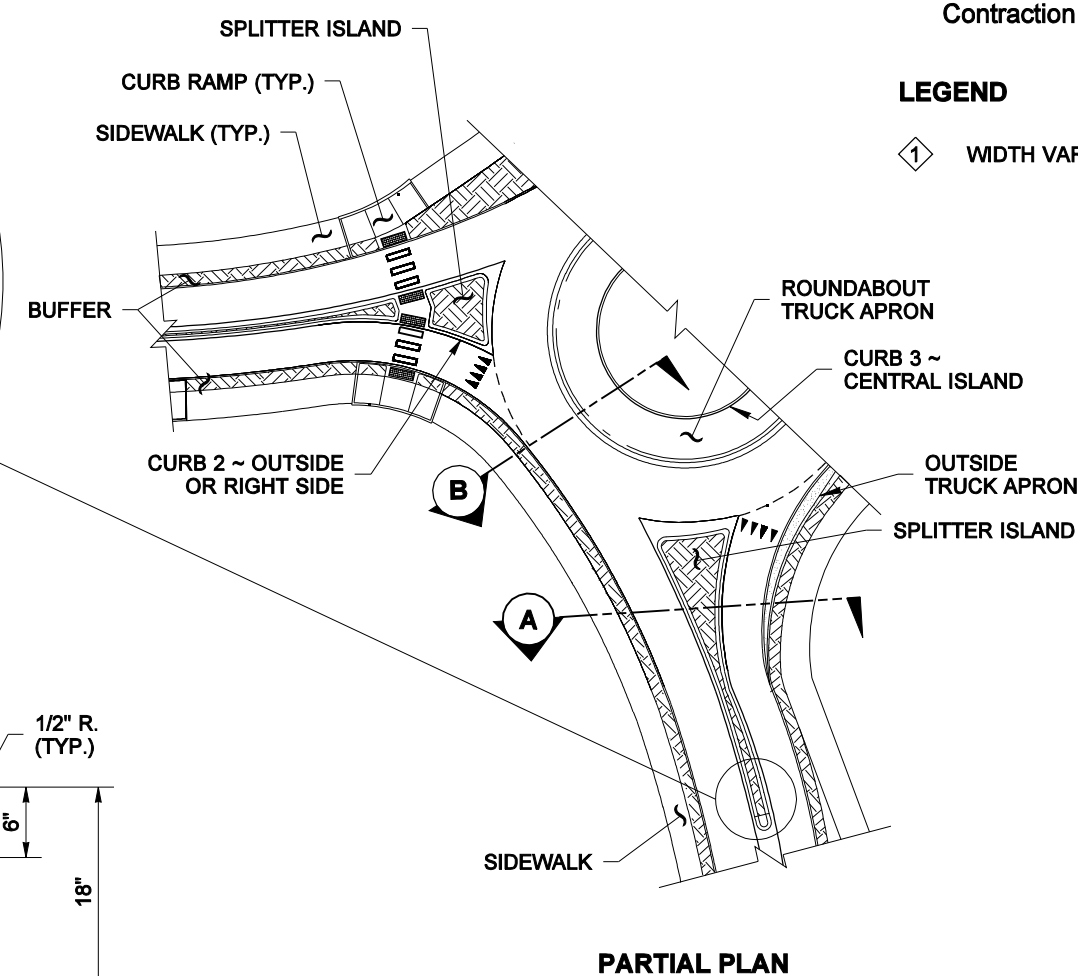

NOTE: THIS PLAN IS NOT A LEGAL ENGINEERING DOCUMENT UNTIL ELECTRONICALLY SIGNED BY THE ENGINEER AND APPROVED FOR PUBLICATION. IT IS KEPT ON FILE AT THE WASHINGTON STATE DEPARTMENT OF TRANSPORTATION. A COPY MAY BE OBTAINED UPON REQUEST.

**ROUNDABOUT CEMENT
CONCRETE CURBS**
STANDARD PLAN F-10.18-00

SHEET 1 OF 1 SHEET

APPROVED FOR PUBLICATION

Pasco Bakotich III 06-27-11
STATE DESIGN ENGINEER DATE



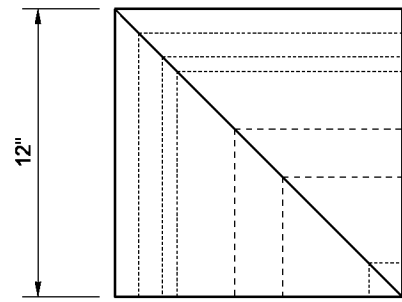

TOP VIEW
INSIDE CORNER BLOCK

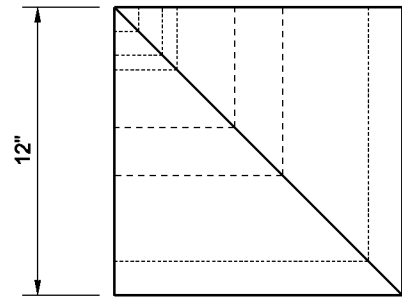

TOP VIEW
OUTSIDE CORNER BLOCK

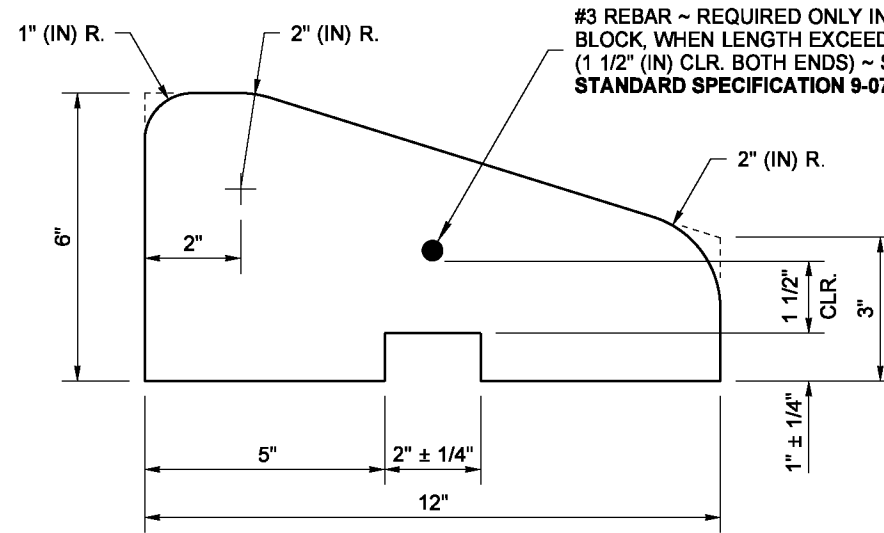

#3 REBAR ~ REQUIRED ONLY IN TANGENT BLOCK, WHEN LENGTH EXCEEDS 30" (IN)
(1 1/2" (IN) CLR. BOTH ENDS) ~ SEE STANDARD SPECIFICATION 9-07

TYPICAL OF ALL
END VIEW

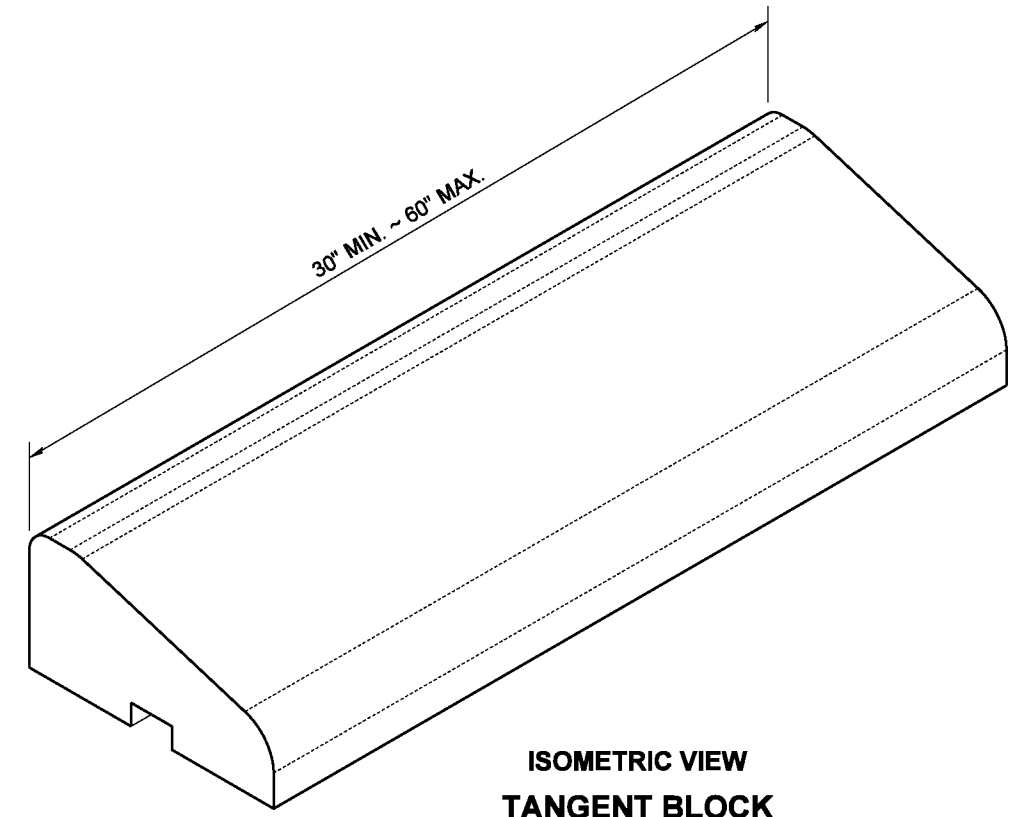

ISOMETRIC VIEW
TANGENT BLOCK

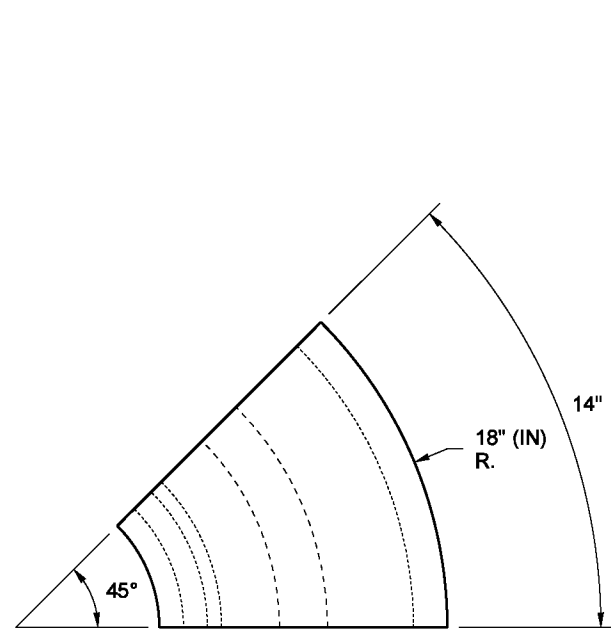

TOP VIEW
18" RADIUS BLOCK

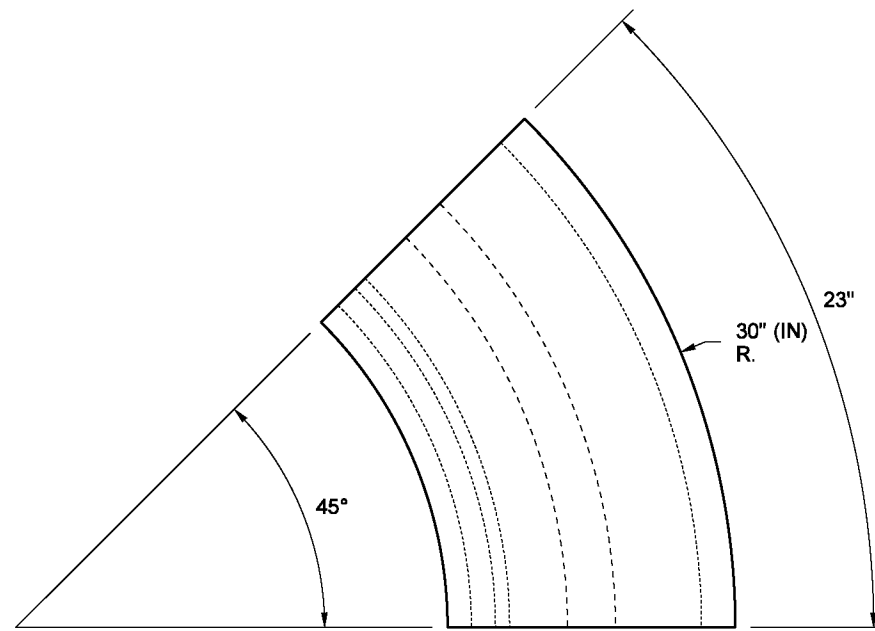

TOP VIEW
30" RADIUS BLOCK

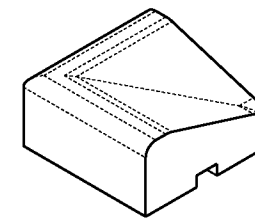

INSIDE CORNER BLOCK

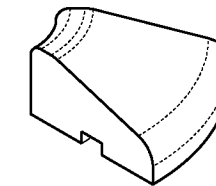

18" (IN) RADIUS BLOCK

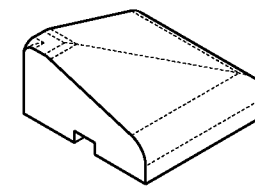

OUTSIDE CORNER BLOCK

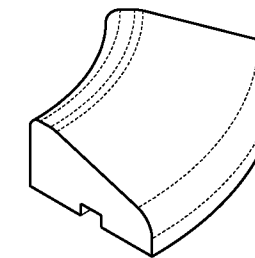

30" (IN) RADIUS BLOCK

ISOMETRIC VIEWS



**PRECAST SLOPED
MOUNTABLE CURB
STANDARD PLAN F-10.62-02**

SHEET 1 OF 2 SHEETS

APPROVED FOR PUBLICATION

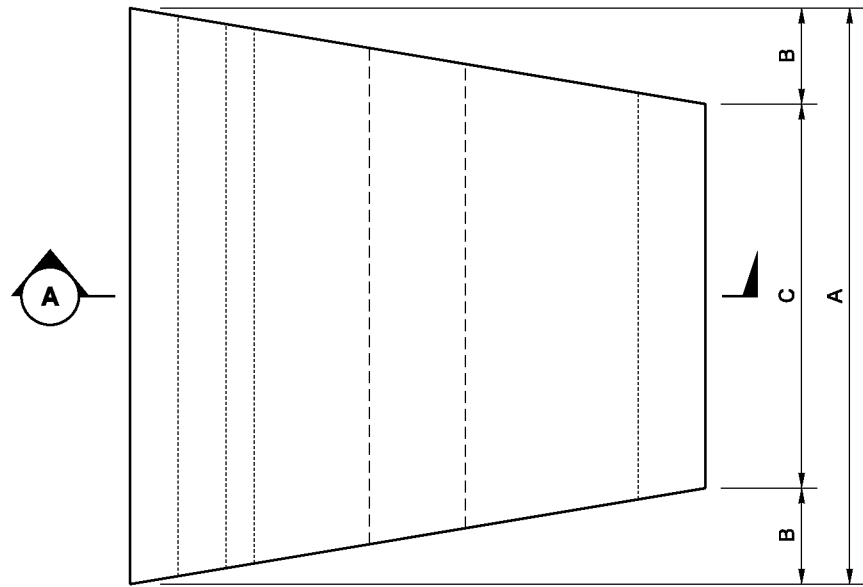

TOP VIEW
INSIDE RADIUS BLOCK

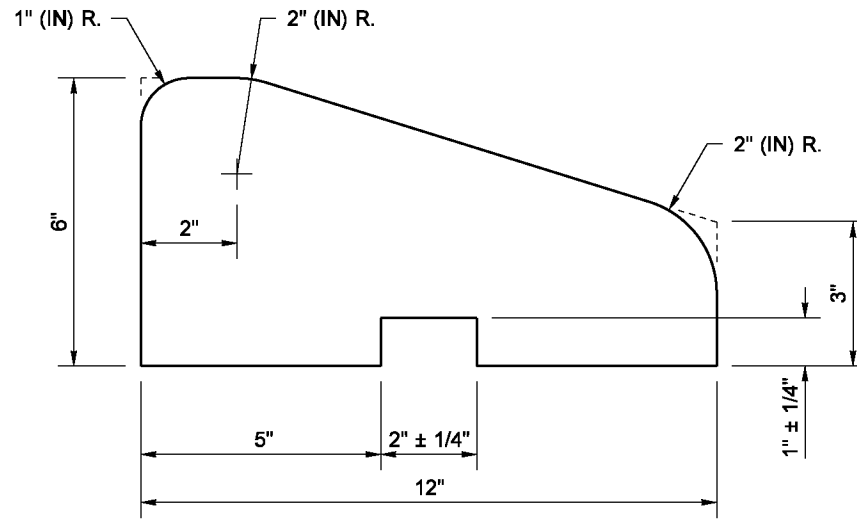

SECTION A

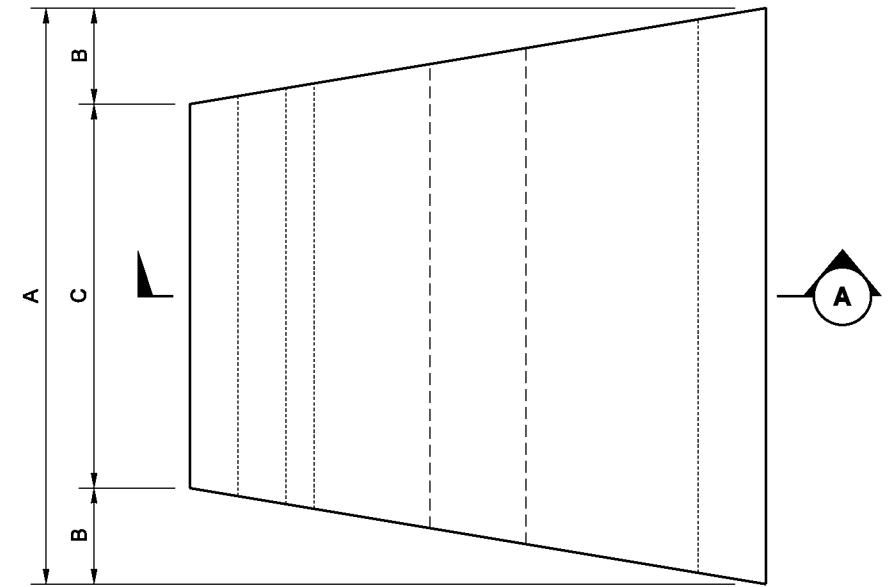

TOP VIEW
OUTSIDE RADIUS BLOCK

CURB RADIUS TABLE			
CURB RADIUS	DIMENSION A	DIMENSION B	DIMENSION C
3'	12"	2"	8"
4' TO 5'	12"	1 1/2"	9"
6'	12"	1"	10"
7'	12"	7/8"	10 1/4"
8'	18"	1 1/8"	15 3/4"
9'	18"	1"	16"
10'	18"	7/8"	16 1/4"
11' TO 13'	18"	3/4"	16 1/2"
14' TO 15'	18"	5/8"	16 3/4"
16' TO 17'	24"	3/4"	22 1/2"
18' TO 22'	24"	5/8"	22 3/4"
23' TO 29'	24"	1/2"	23"
30' TO 34'	30"	1/2"	29"
35' TO 48'	30"	3/8"	29 1/4"
49' TO 60'	30"	1/4"	29 1/2"
OVER 60'	USE TANGENT BLOCK, SEE SHEET 1		

THIS TABLE LISTS THE CALCULATED DIMENSIONS FOR CASTING BLOCKS SUITABLE FOR CONSTRUCTING VARIOUS CURB RADII. CURVED BLOCKS, OR BLOCKS WITH DIFFERENT DIMENSIONS MAY BE ACCEPTABLE WITH PRIOR APPROVAL OF THE ENGINEER.

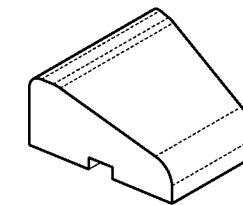

INSIDE RADIUS BLOCK

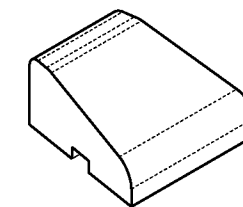

OUTSIDE RADIUS BLOCK

ISOMETRIC VIEWS



PRECAST SLOPED MOUNTABLE CURB
STANDARD PLAN F-10.62-02

SHEET 2 OF 2 SHEETS

APPROVED FOR PUBLICATION

DRAWN BY: FERN LIDDELL

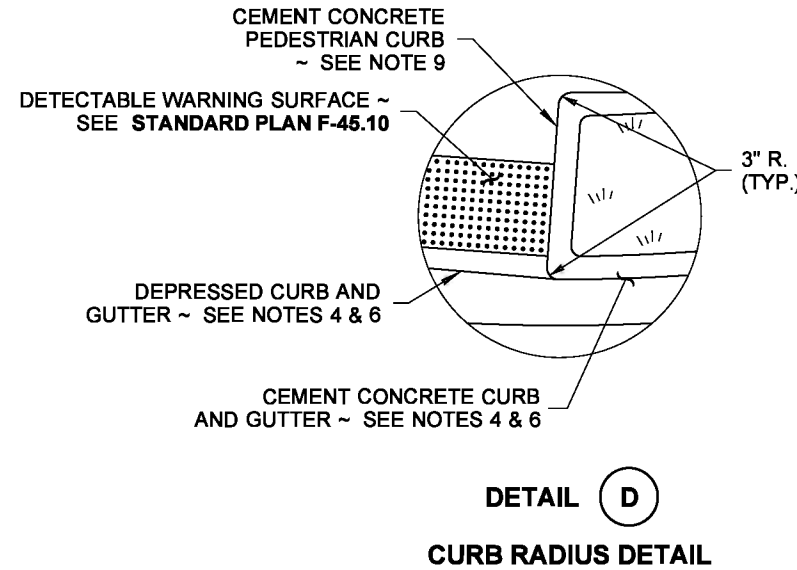
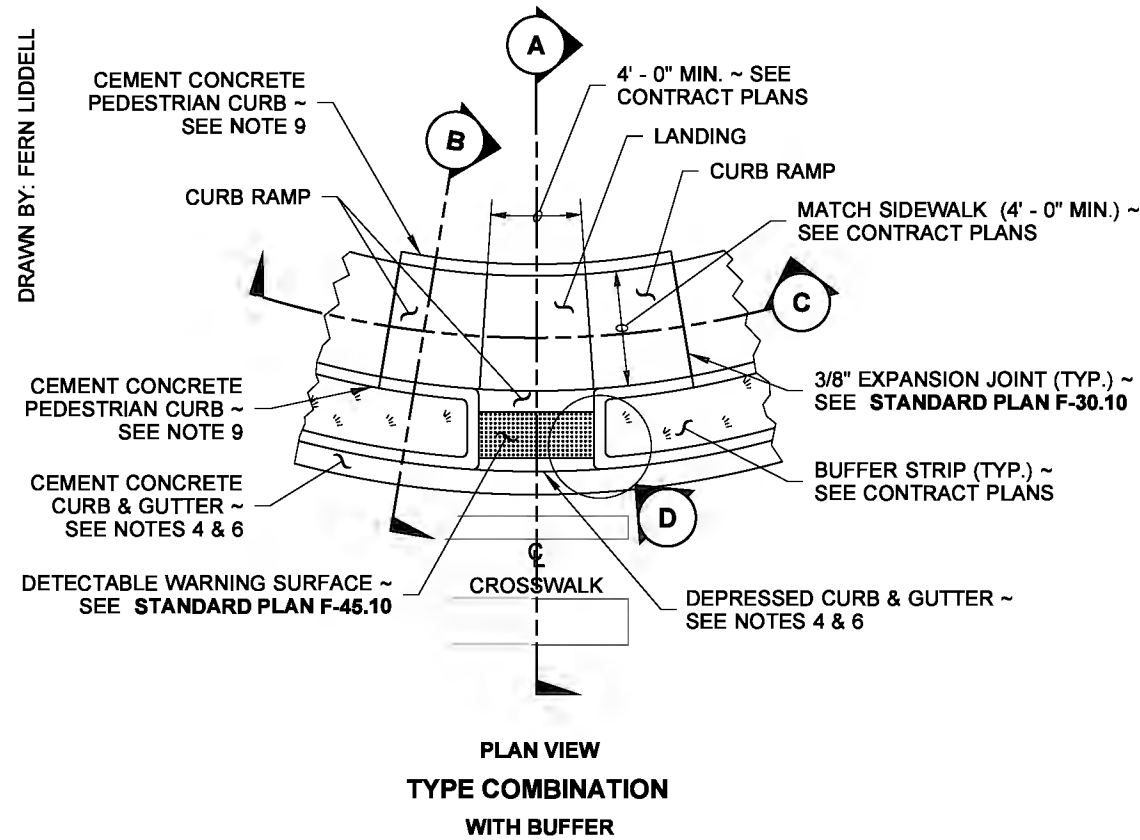

NOTES

1. Provide a separate Curb Ramp for each marked or unmarked crosswalk. Curb Ramp location shall be placed within the width of the associated crosswalk or as shown in the Contract Plans.
2. Where "GRADE BREAK" is called out, the entire length of the grade break between the two adjacent surface planes shall be flush.
3. Do not place Gratings, Junction Boxes, Access Covers, or other appurtenances in front of the Curb Ramp or on any part of the Curb Ramp or Landing.
4. See Contract Plans for the curb design specified. See **Standard Plan F-10.12** for Curb, Curb and Gutter, Depressed Curb, Gutter and Pedestrian Curb details.
5. See **Standard Plan F-30.10** for Cement Concrete Sidewalk Details. See Contract Plans for width and placement of sidewalk.
6. The Bid Item "Cement Concrete Curb Ramp Type __" does not include the adjacent Curb, Curb and Gutter, Depressed Curb and Gutter, Pedestrian Curb, or Sidewalks.
7. The Curb Ramp maximum running slope shall not require the ramp length to exceed 15 feet to avoid chasing the slope indefinitely when connecting to steep grades. When applying the 15-foot max. length, the running slope of the Curb Ramp shall be as flat as feasible.
8. Curb Ramp, Landing and Flares shall receive broom finish. See **Standard Specifications 8-14**.
9. Pedestrian Curb may be omitted if the ground surface at the back of the Curb Ramp and/or Landing will be at the same elevation as the Curb Ramp or Landing and there will not be material to retain.

LEGEND

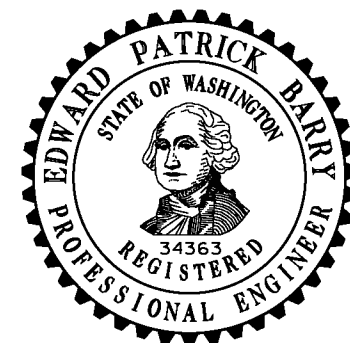
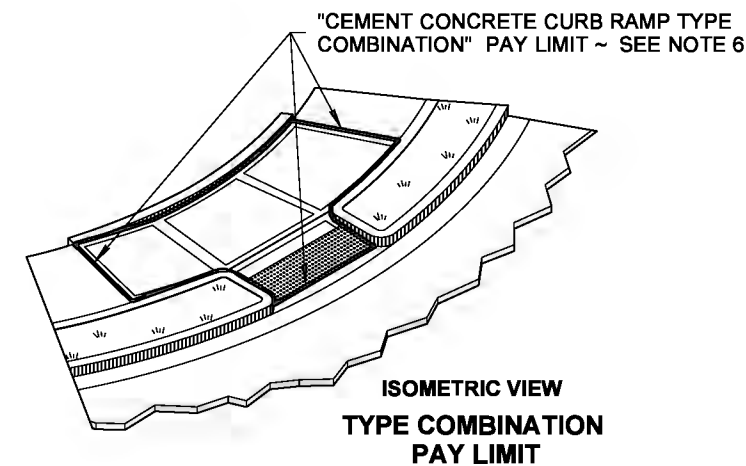
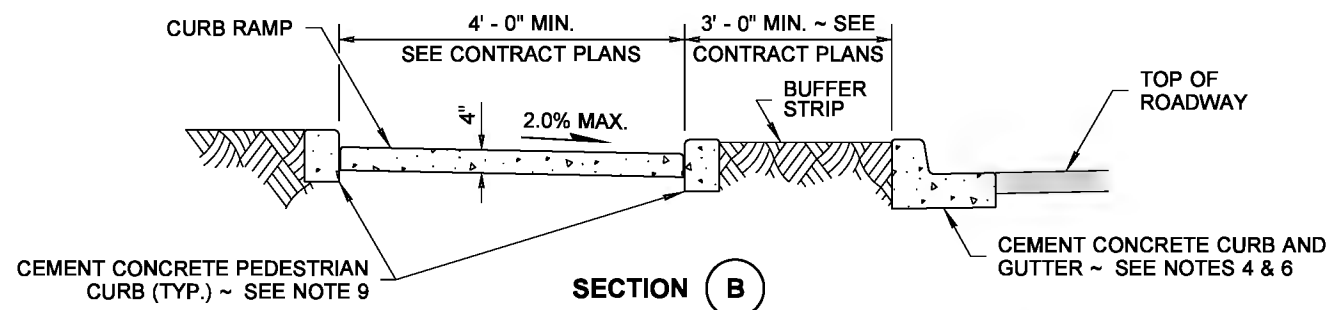
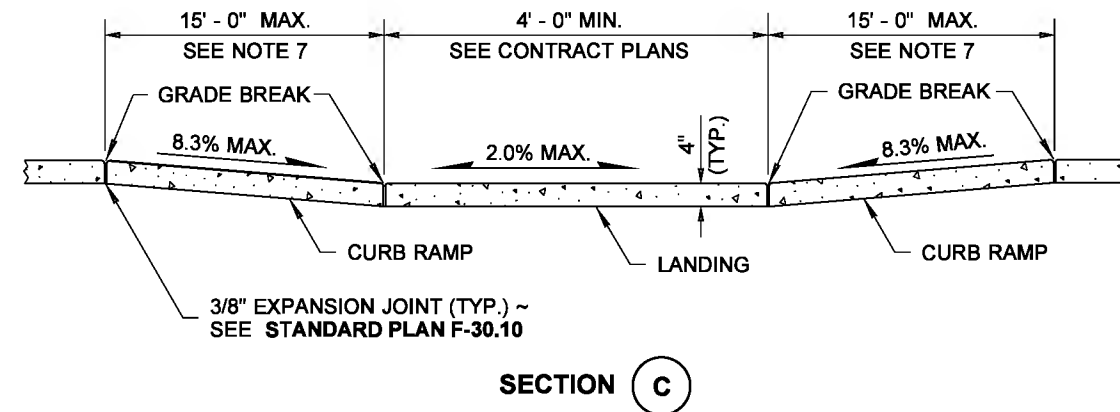
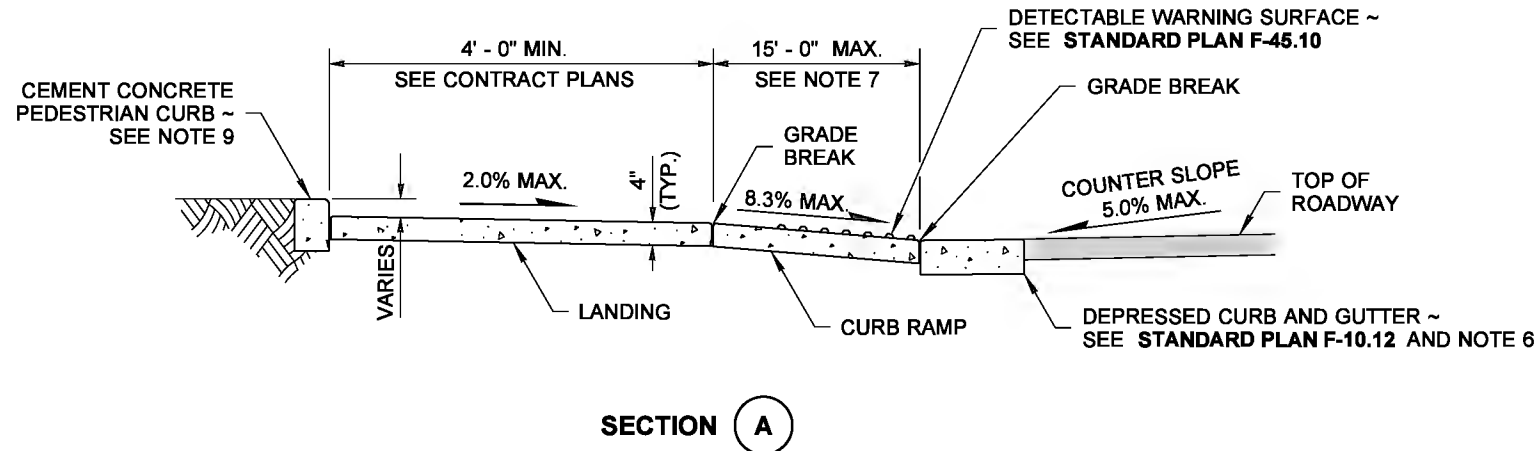

NOTE: THIS PLAN IS NOT A LEGAL ENGINEERING DOCUMENT UNTIL IT IS APPROVED AND SIGNED BY THE ENGINEER AND THE ENGINEER'S SEAL IS FILED AT THE WASHINGTON STATE DEPARTMENT OF TRANSPORTATION. A COPY MAY BE OBTAINED UPON REQUEST.

**COMBINATION CURB RAMP
STANDARD PLAN F-40.14-02**

SHEET 1 OF 1 SHEET

APPROVED FOR PUBLICATION

Pasco Bakotich III 6/20/13
STATE DESIGN ENGINEER DATE

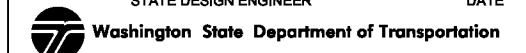

DRAWN BY: FERN LIDDELL

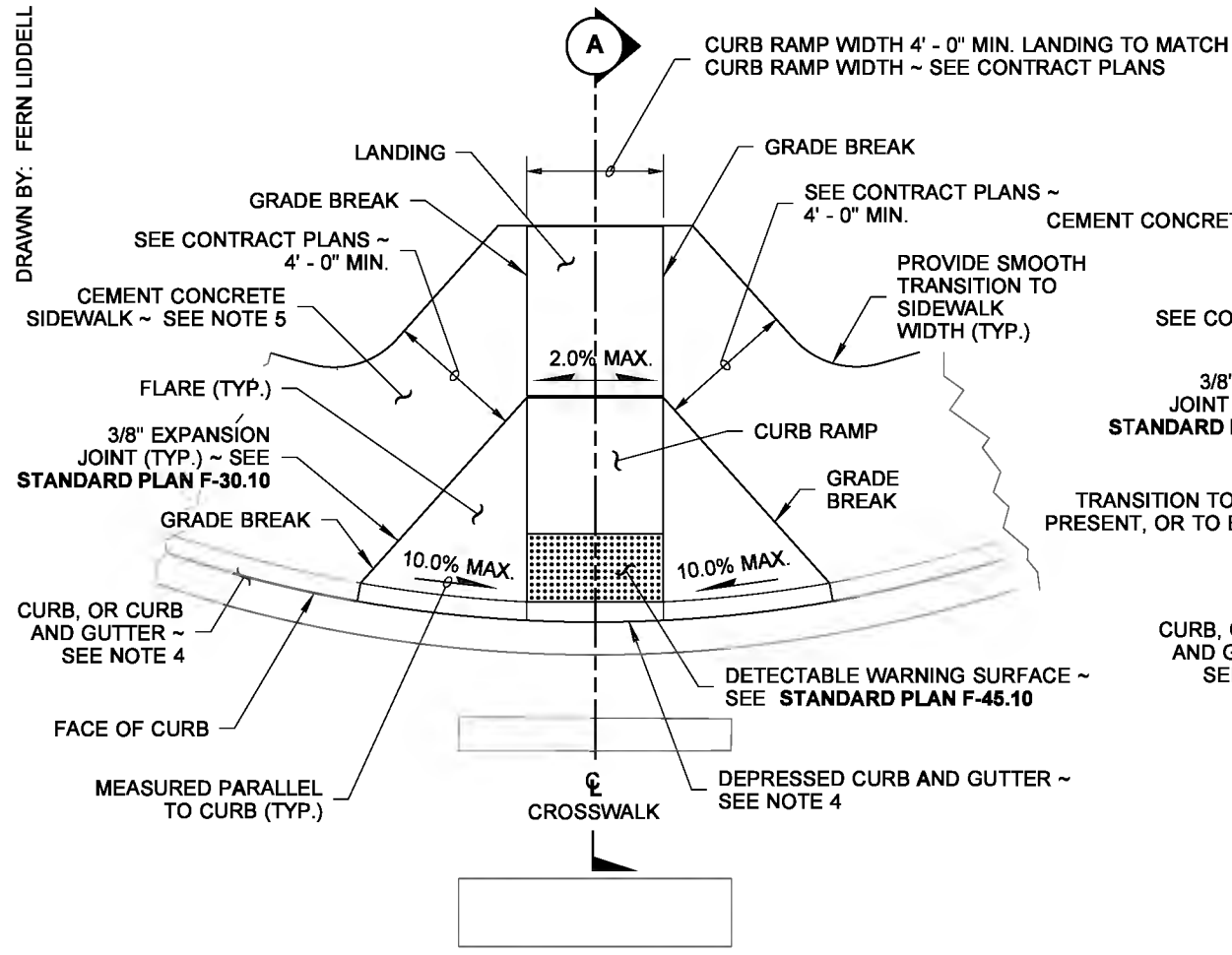

**PLAN VIEW
TYPE PERPENDICULAR A**

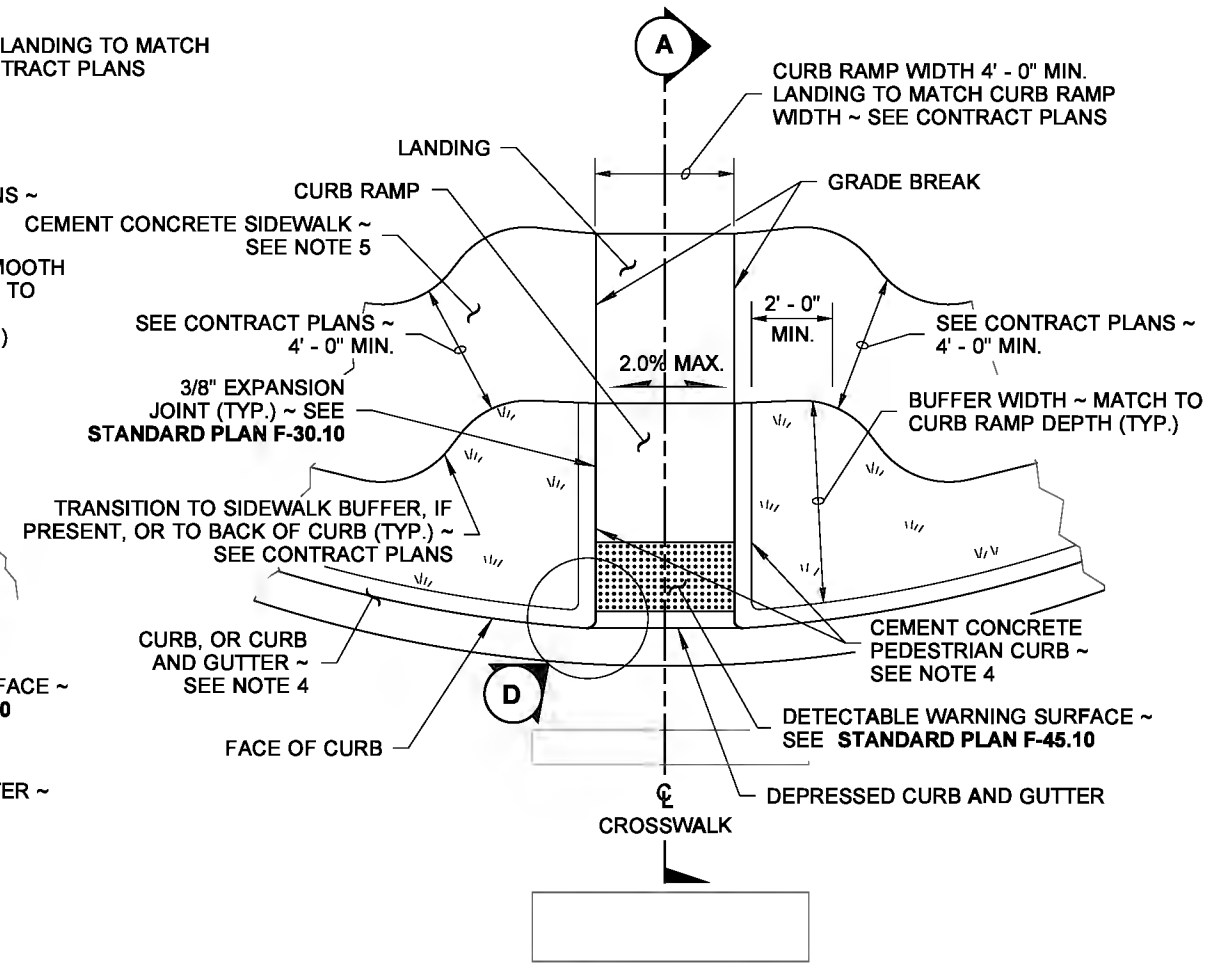

**PLAN VIEW
TYPE PERPENDICULAR B
(SHOWN WITH BUFFER)**

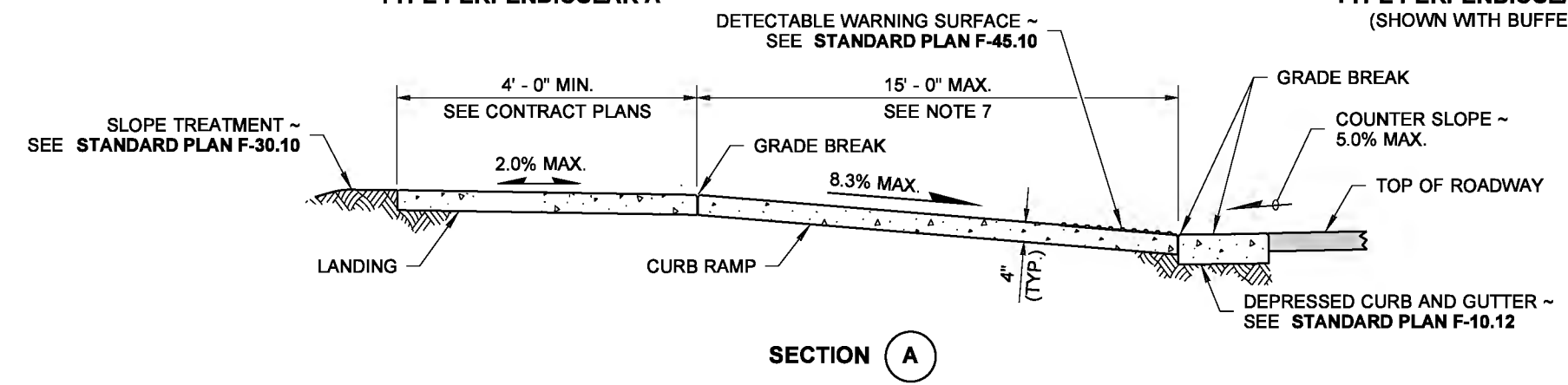

SECTION A

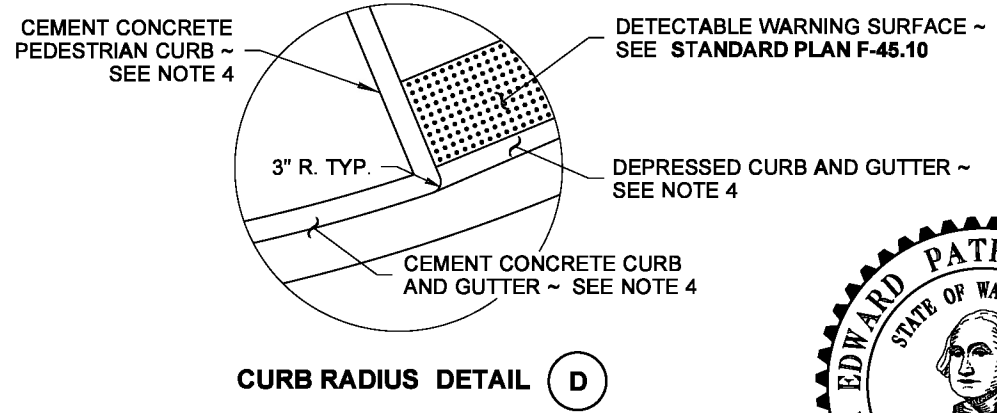

CURB RADIUS DETAIL D

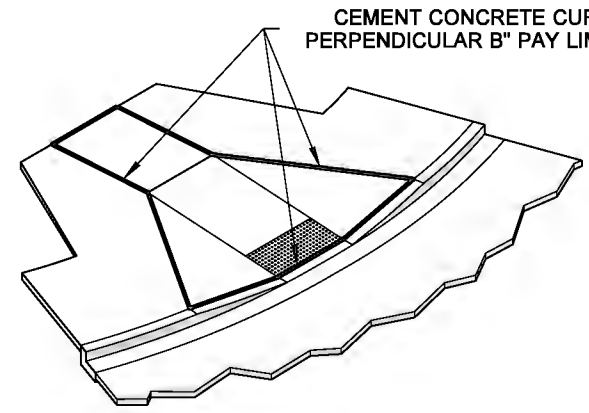

**ISOMETRIC VIEW
TYPE PERPENDICULAR A PAY LIMIT**

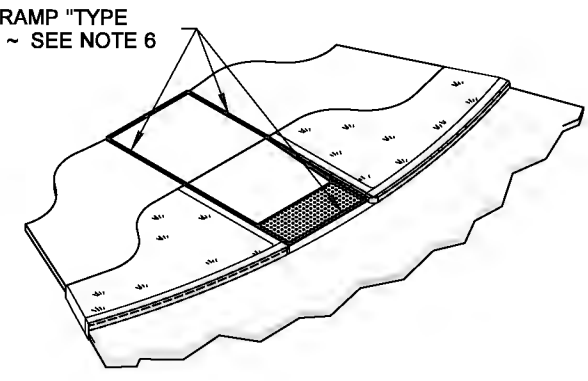

**ISOMETRIC VIEW
TYPE PERPENDICULAR B PAY LIMIT**

NOTES

1. Provide a separate Curb Ramp for each marked or unmarked crosswalk. Curb Ramp location shall be placed within the width of the associated crosswalk or as shown in the Contract Plans.
2. Where "GRADE BREAK" is called out, the entire length of the grade break between the two adjacent surface planes shall be flush.
3. Do not place Gratings, Junction Boxes, Access Covers, or other appurtenances in front of the Curb Ramp or on any part of the Curb Ramp or Landing.
4. See the Contract Plans for the curb design specified. See **Standard Plan F-10.12** for Curb, Curb and Gutter, Depressed Curb and Gutter, and Pedestrian Curb details.
5. See **Standard Plan F-30.10** for Cement Concrete Sidewalk details. See Contract Plans for width and placement of sidewalk.
6. The Bid Item "Cement Concrete Curb Ramp Type ___" does not include the adjacent Curb, Curb and Gutter, Depressed Curb and Gutter, Pedestrian Curb, or Sidewalk.
7. The Curb Ramp maximum running slope shall not require the ramp length to exceed 15-feet to avoid chasing the slope indefinitely when connecting to steep grades. When applying the 15-foot maximum length, the running slope of the Curb Ramp shall as flat as feasible.
8. Curb Ramp, Landing, and Flares shall receive broom finish. See **Standard Specifications 8-14**.

LEGEND

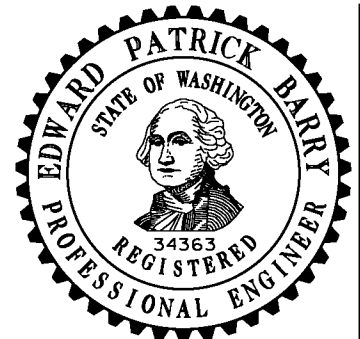

NOTE: THIS PLAN IS NOT A LEGAL ENGINEERING DOCUMENT UNTIL IT IS SIGNED AND SEALED BY THE ORIGINAL DESIGNER. THE ORIGINAL DESIGNER'S SIGNATURE AND SEAL MUST BE FILED AT THE WASHINGTON STATE DEPARTMENT OF TRANSPORTATION. A COPY MAY BE OBTAINED UPON REQUEST.

**PERPENDICULAR
CURB RAMP
STANDARD PLAN F-40.15-02**

SHEET 1 OF 1 SHEET

APPROVED FOR PUBLICATION
Pasco Bakotich III 6/20/13
 STATE DESIGN ENGINEER DATE
 Washington State Department of Transportation

DRAWN BY: FERN LIDDELL

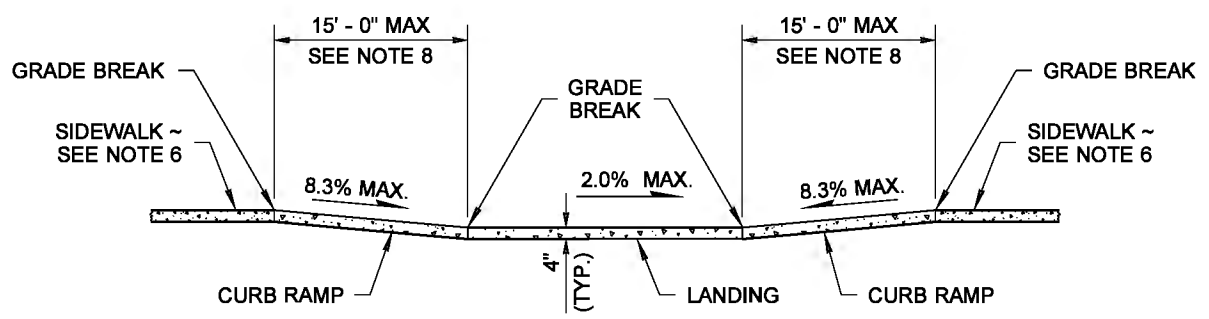
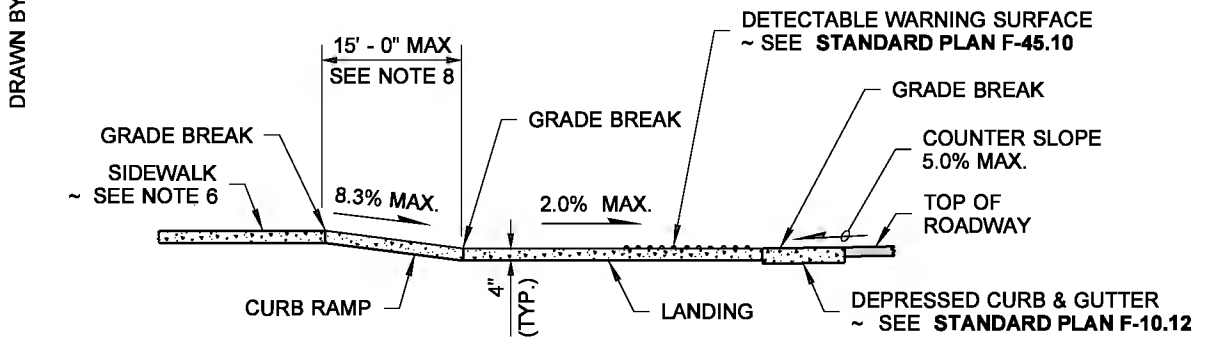
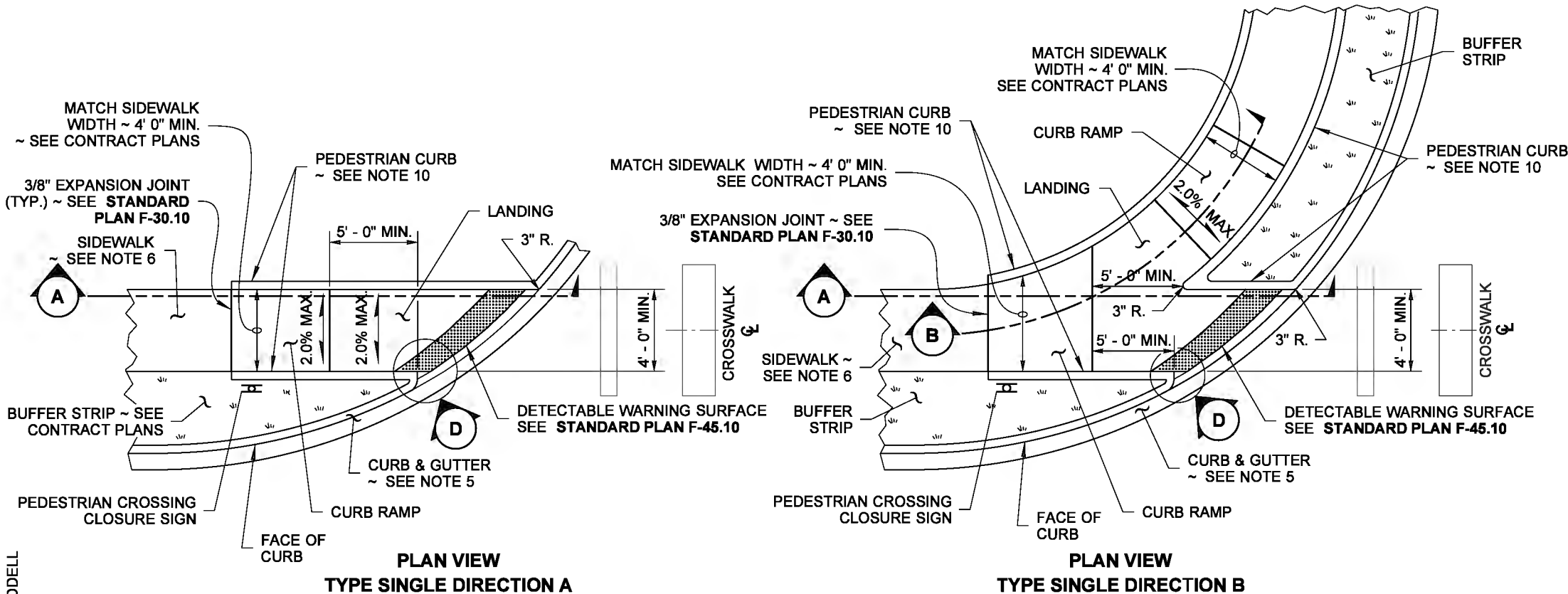

LEGEND
 SLOPE IN EITHER DIRECTION

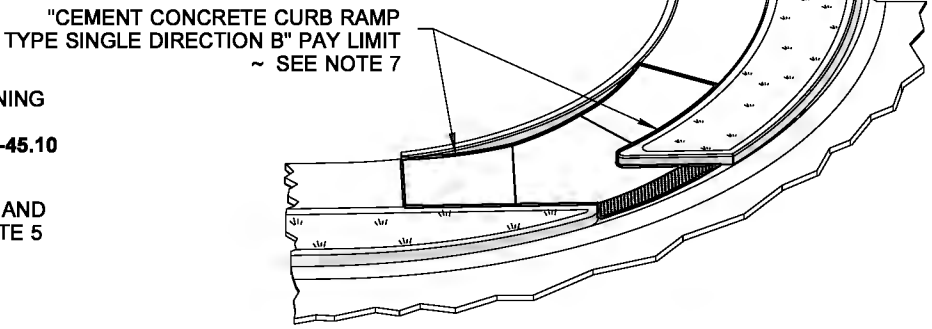
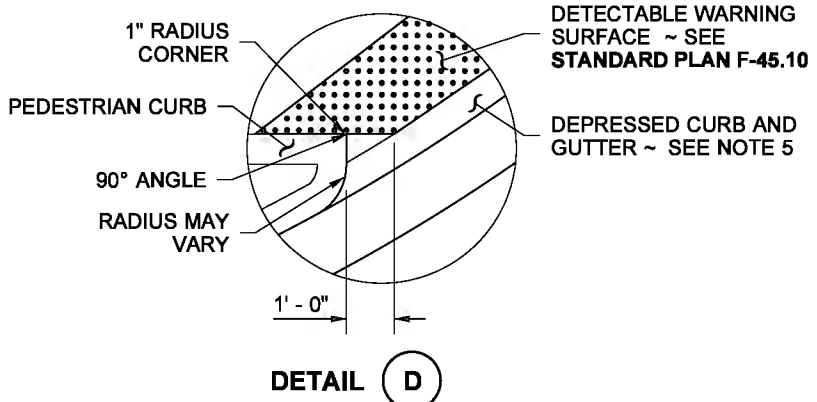
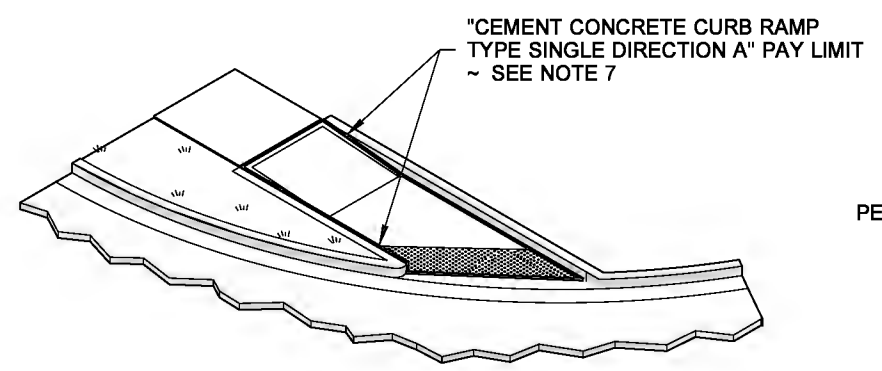

NOTES

1. This plan is to be used where pedestrian crossing in one direction is not permitted.
2. Curb ramp location shall be placed within the width of the associated crosswalk, or as shown in the Contract Plans.
3. Where "GRADE BREAK" is called out, the entire length of the grade break between the two adjacent surface planes shall be flush.
4. Do not place gratings, junction boxes, access covers or other appurtenances in front of the curb ramp or on any part of the curb ramp or landing.
5. See the Contract Documents for the curb design specified. See **Standard Plan F-10.12** for Curb, Curb and Gutter, Depressed Curb and Gutter and Pedestrian Curb details.
6. See **Standard Plan F-30.10** for Cement Concrete Sidewalk Details. See contract plans for width and placement of sidewalk.
7. The bid item "Cement Concrete Curb Ramp Type ___" does not include the adjacent Curb or (Curb and Gutter), Depressed Curb and Gutter, Pedestrian Curb or Sidewalk, or the pedestrian crossing closure sign.
8. The curb ramp maximum running slope shall not require the ramp length to exceed 15 feet to avoid chasing the slope indefinitely when connecting to steep grades. When applying the 15 foot maximum length, the running slope of the curb ramp shall be as flat as feasible.
9. Curb ramps and landings shall receive broom finish. See **Standard Specifications 8-14**.
10. Pedestrian Curb may be omitted if the ground surface at the back of the Curb Ramp and/or landing will be at the same elevation as the Curb Ramp or Landing and there will be no material to retain.

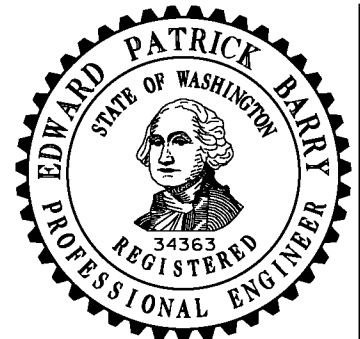

NOTE: THIS PLAN IS NOT A LEGAL ENGINEERING DOCUMENT UNTIL IT IS APPROVED AND SIGNED BY THE ENGINEER AND PROJECT OR FILED AT THE WASHINGTON STATE DEPARTMENT OF TRANSPORTATION. A COPY MAY BE OBTAINED UPON REQUEST.

SINGLE DIRECTION CURB RAMP
STANDARD PLAN F-40.16-02

SHEET 1 OF 1 SHEET

APPROVED FOR PUBLICATION

Pasco Bakotich III 6/20/13
 STATE DESIGN ENGINEER DATE

Washington State Department of Transportation

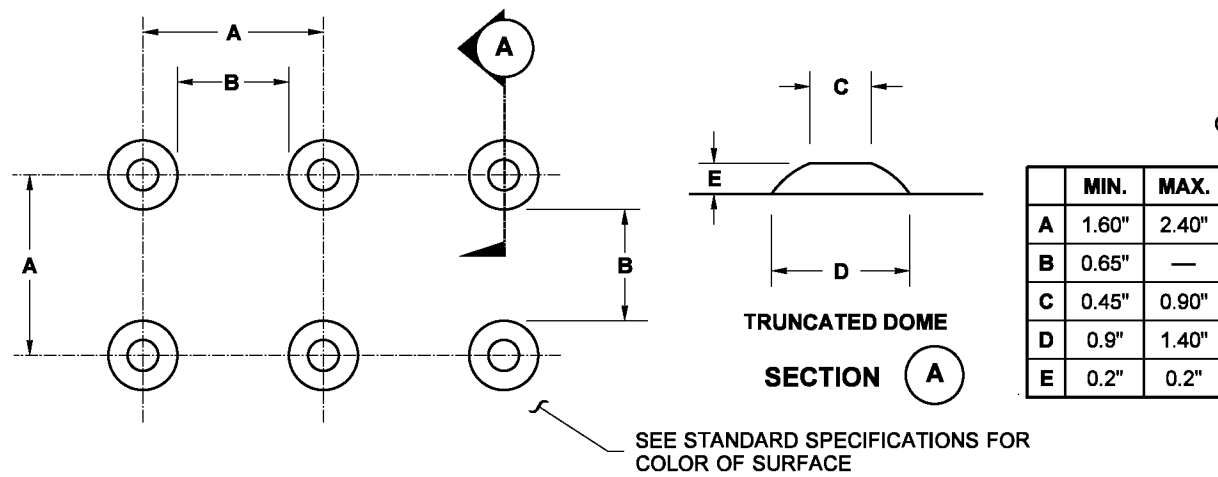

TRUNCATED DOME SPACING
SEE NOTE 3

TRUNCATED DOME DETAILS

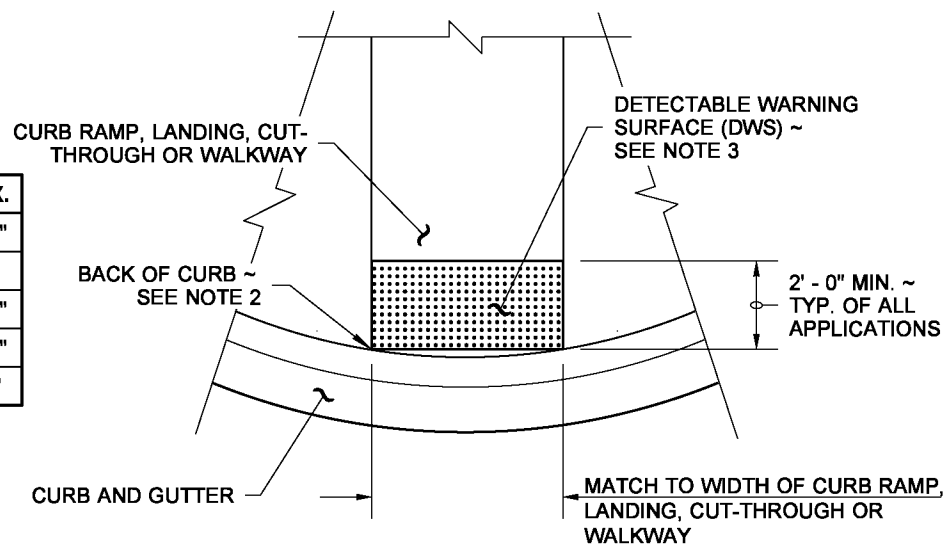

DETECTABLE WARNING SURFACE DETAIL

NOTES

1. The Detectable Warning Surface (DWS) shall extend the full width of the curb ramp (exclusive of flares) or the landing.
2. The Detectable Warning Surface shall be placed at the back of curb, and need not follow the radius.
3. The rows of truncated domes shall be aligned to be perpendicular to the grade break at the back of curb.
4. The rows of truncated domes shall be aligned to be parallel to the direction of travel.
5. If curb and gutter are not present, such as a shared-use path connection, the Detectable Warning Surface shall be placed at the pavement edge.
6. See **Standard Plans** for sidewalk and curb ramp details.
7. If a curb ramp is required, the location of the Detectable Warning Surface must be at the bottom of the ramp and within the required distance from the rail.
8. When the grade break between the curb ramp and the landing is less than or equal to 5 ft. from the back of curb at all points, place the Detectable Warning Surface on the bottom of the curb ramp.

DRAWN BY: FERN LIDDELL

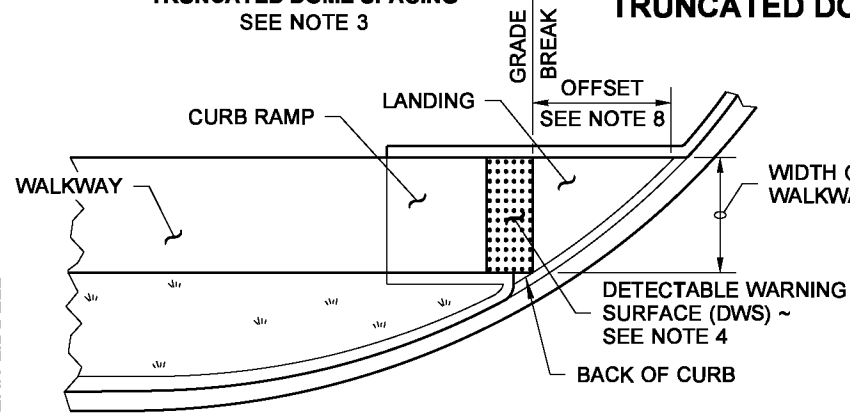

SINGLE DIRECTION CURB RAMP
(GRADE BREAK BETWEEN CURB AND LANDING \leq 5 FT. FROM BACK OF CURB)
(SEE NOTE 6)

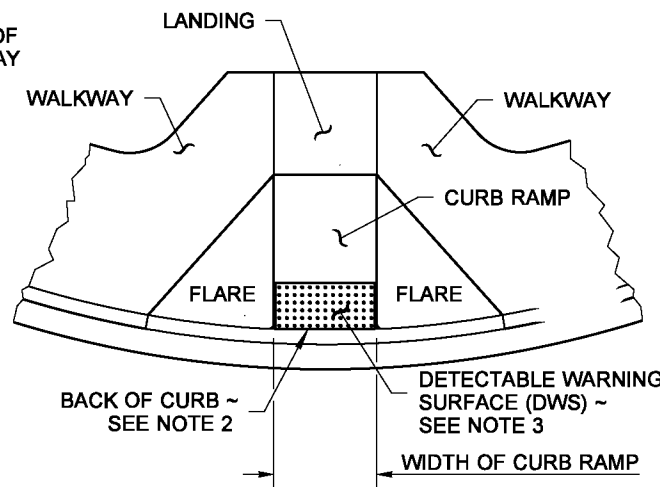

PERPENDICULAR CURB RAMP
(SEE NOTE 6)

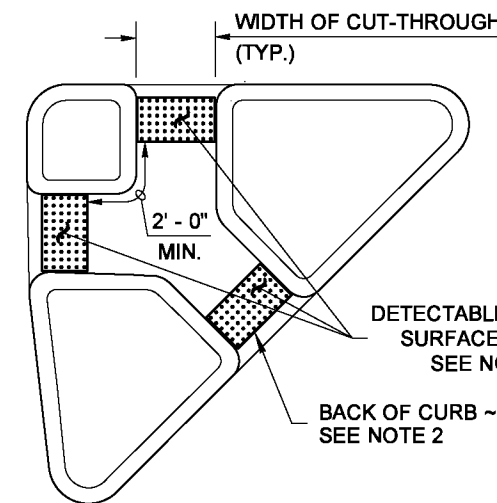

ISLAND CUT-THROUGH

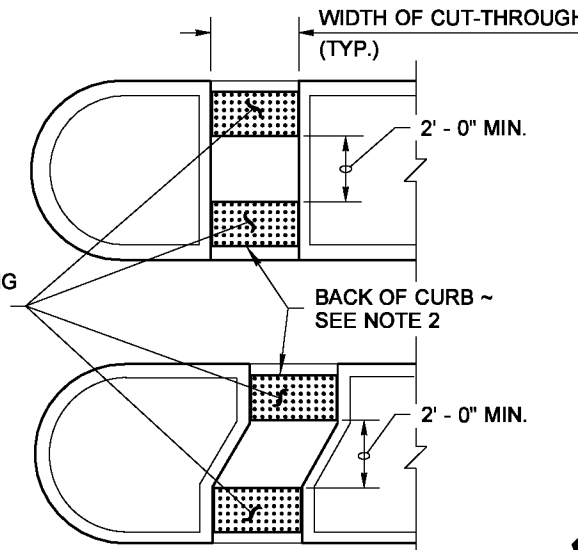

MEDIAN CUT-THROUGH

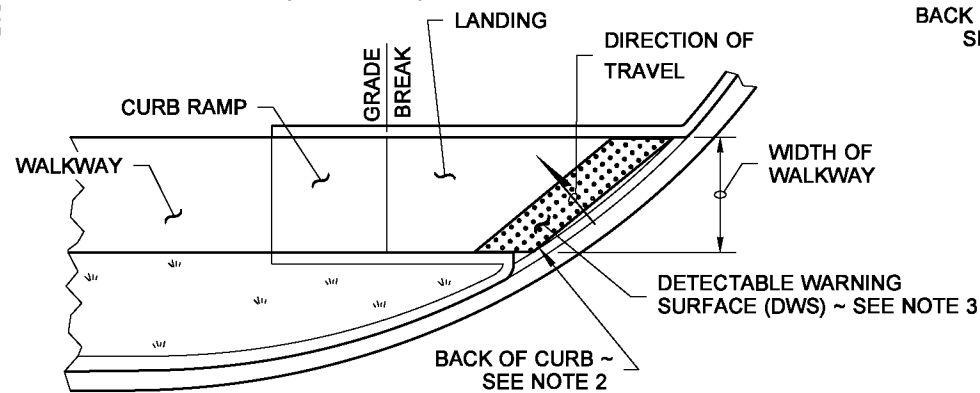

SINGLE DIRECTION CURB RAMP
(GRADE BREAK BETWEEN CURB AND LANDING $>$ 5 FT. FROM BACK OF CURB)
(SEE NOTE 6)

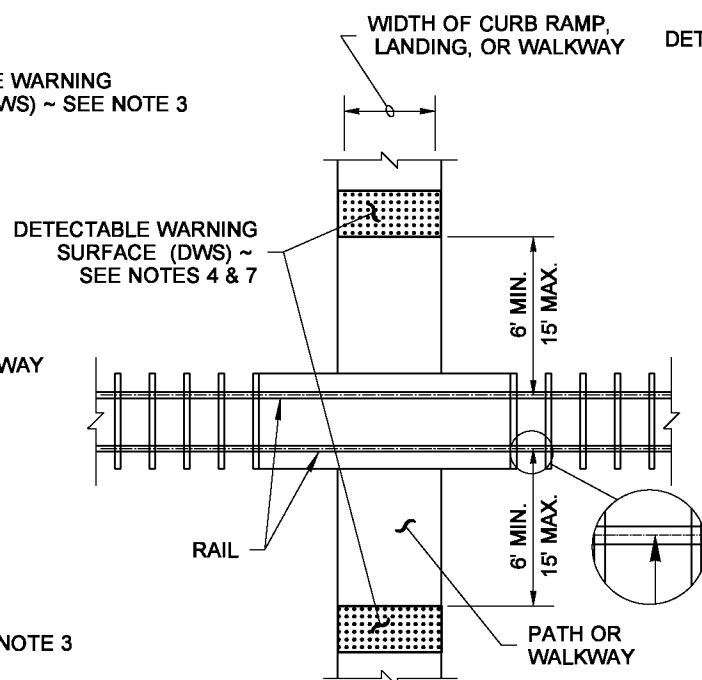

PEDESTRIAN RAILROAD CROSSING

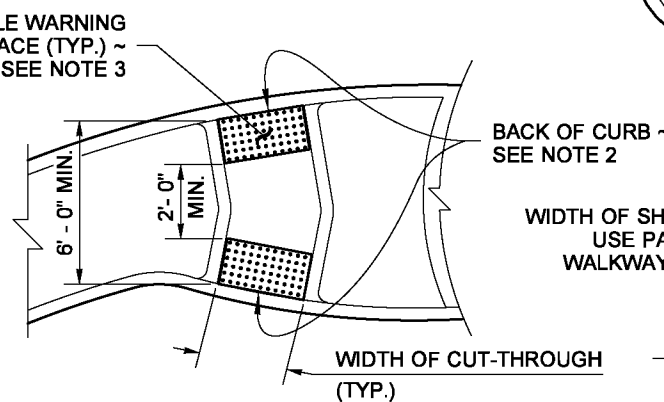

ROUNDABOUT SPLITTER ISLAND

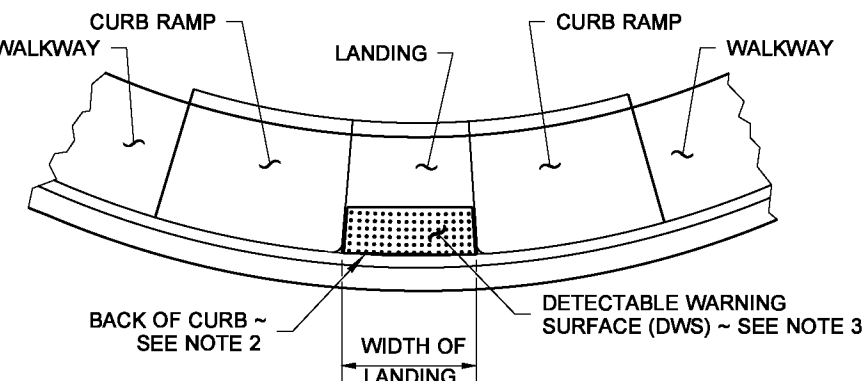

PARALLEL CURB RAMP
(SEE NOTE 6)

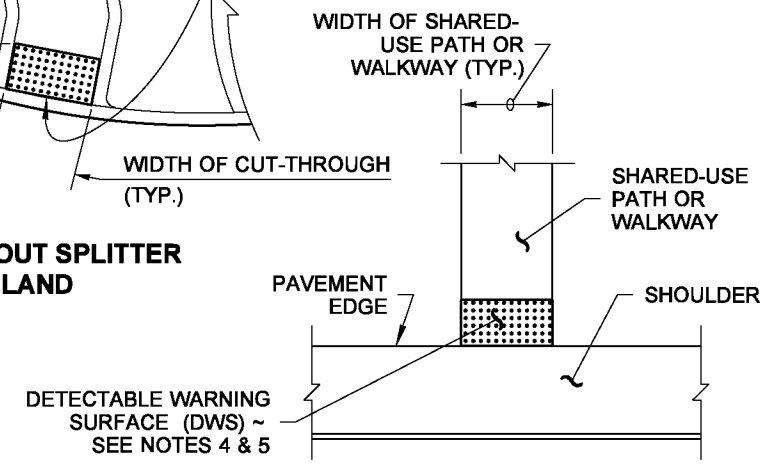

SHARED-USE PATH CONNECTION

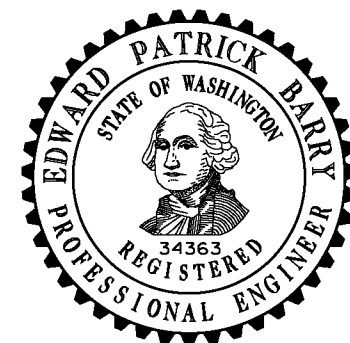

NOTE: THIS PLAN IS NOT A LEGAL ENGINEERING DOCUMENT UNTIL ELECTRONICALLY SIGNED BY THE ENGINEER AND APPROVED FOR PUBLICATION IS KEPT ON FILE AT THE WASHINGTON STATE DEPARTMENT OF TRANSPORTATION. A COPY MAY BE OBTAINED UPON REQUEST.

DETECTABLE WARNING SURFACE
STANDARD PLAN F-45.10-01

SHEET 1 OF 1 SHEET

APPROVED FOR PUBLICATION

Pasco Bakotich III 06/21/12

STATE DESIGN ENGINEER DATE



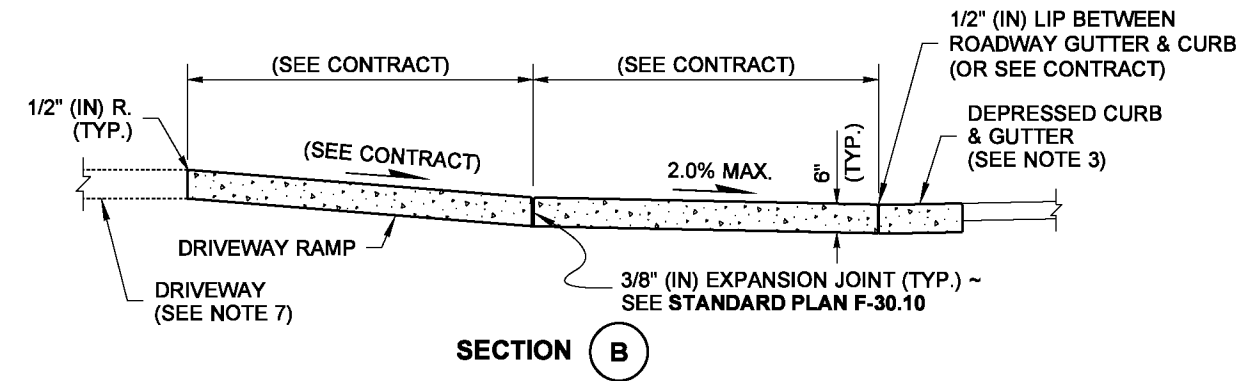
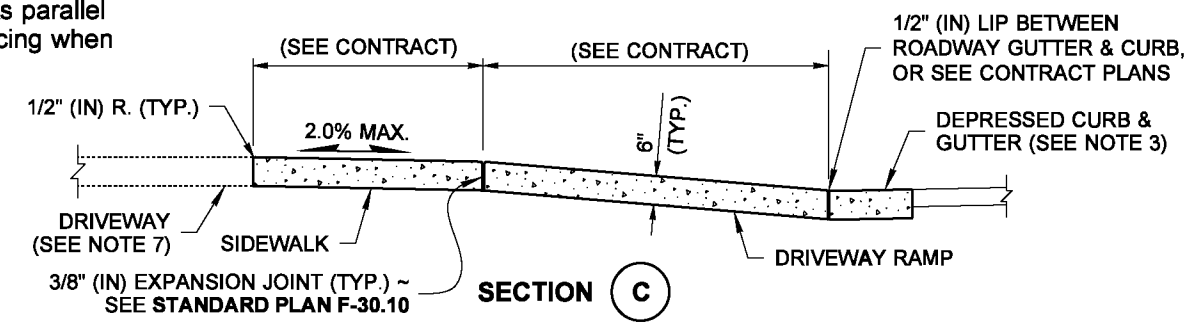
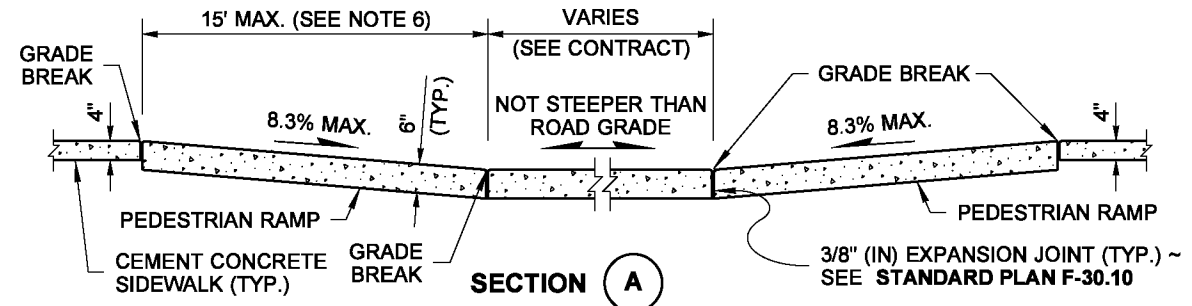
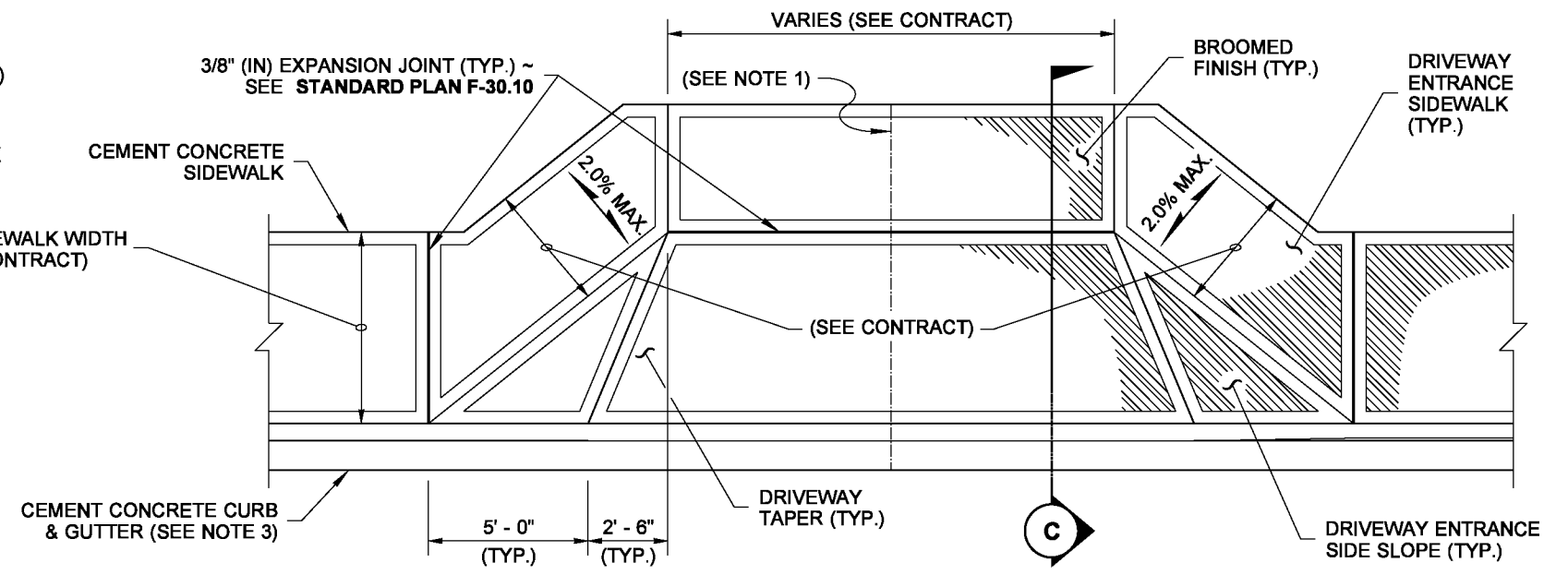
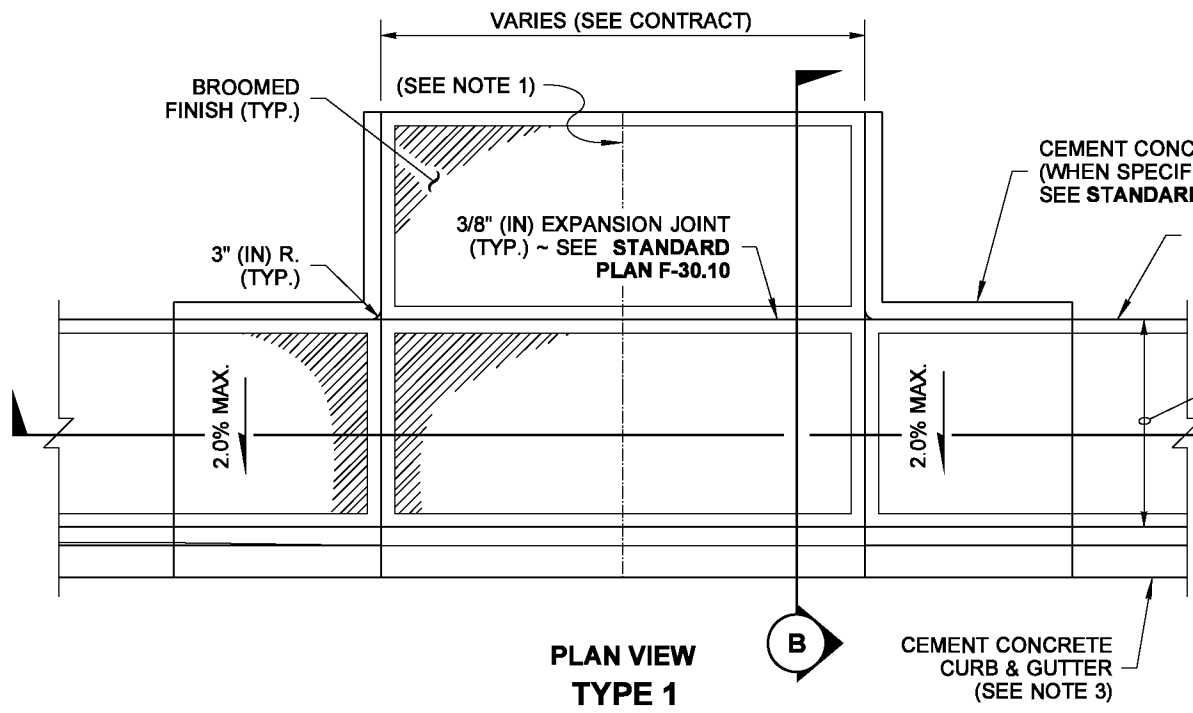

NOTES

1. When the driveway width exceeds 15' (ft), construct a full depth expansion joint with 3/8" (in) joint filler along the driveway centerline. See **Standard Plan F-30.10**. Construct expansion joints parallel with the centerline as required at 15' (ft) maximum spacing when driveway widths exceed 30' (ft).
2. See **Standard Plan F-30.10** for sidewalk details.
3. Curb and gutter shown; see the Contract Plans for the curb design specified. See **Standard Plan F-10.12** for Curb Details.
4. Avoid placing drainage structures, junction boxes or other obstructions in front of driveway entrances.
5. Where "GRADE BREAK" is called out, the entire length of the line between the two adjacent surface planes shall be flush.
6. The curb ramp maximum running slope shall not require the ramp length to exceed 15' (ft) to avoid chasing the slope indefinitely when connecting to steep grades. When applying the 15' (ft) max. length, the running slope of the curb ramp shall be as flat as feasible.
7. Beyond limits shown. Pay item does not include driveway. See Contract Plans.

LEGEND



DRAWN BY: FERN LIDDELL

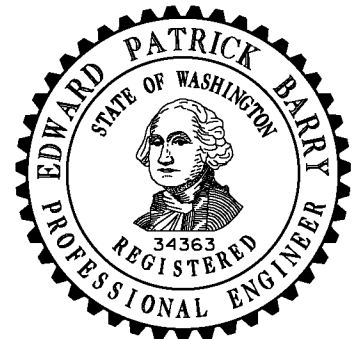
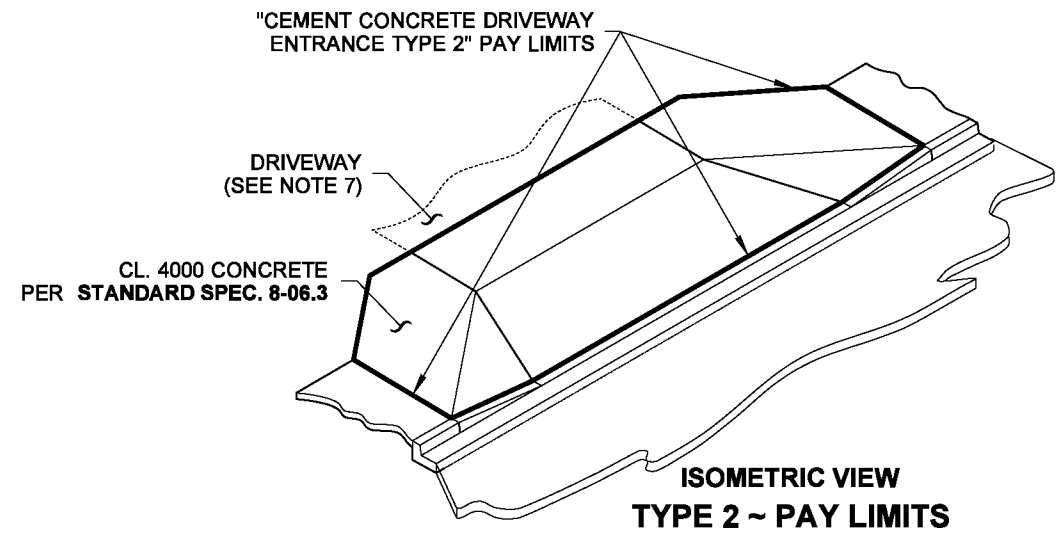
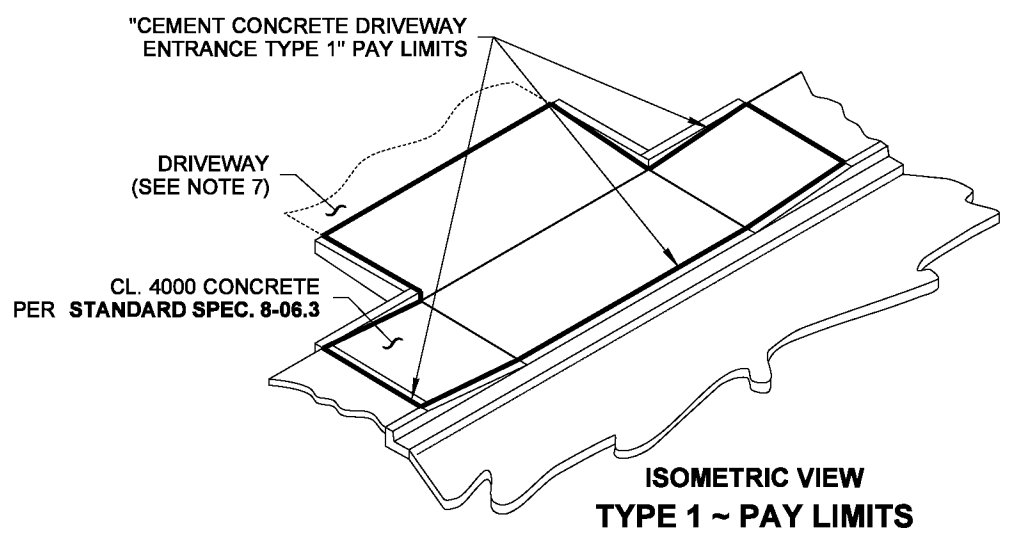

CEMENT CONCRETE DRIVEWAY ENTRANCE TYPES 1, 2, 3, & 4
STANDARD PLAN F-80.10-03
 SHEET 1 OF 2 SHEETS

APPROVED FOR PUBLICATION

STATE DESIGN ENGINEER
 Washington State Department of Transportation

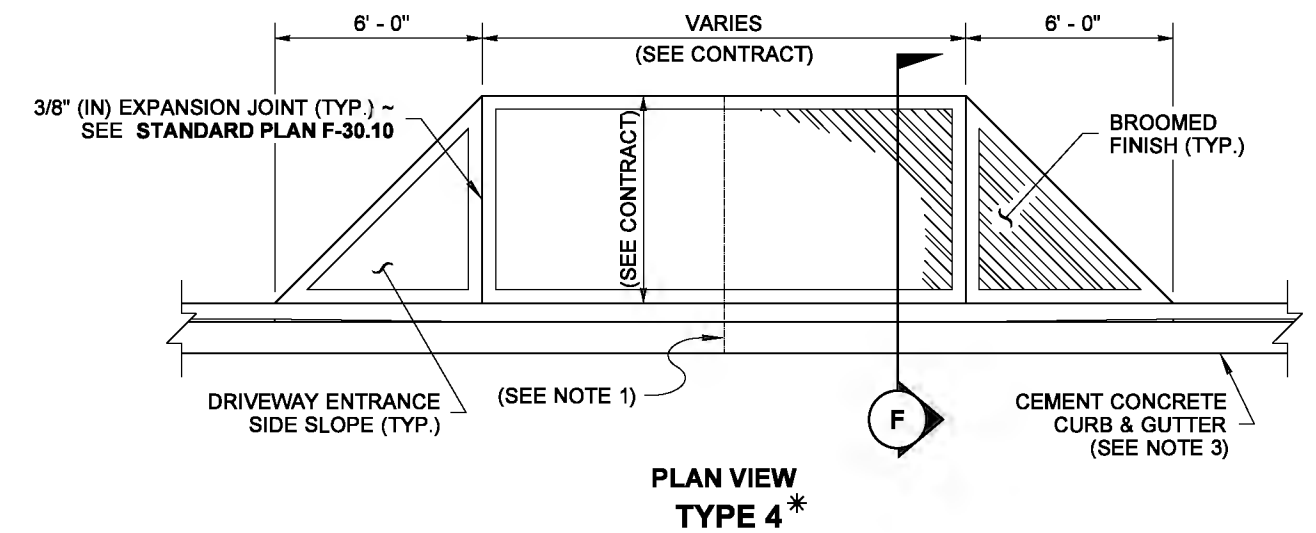
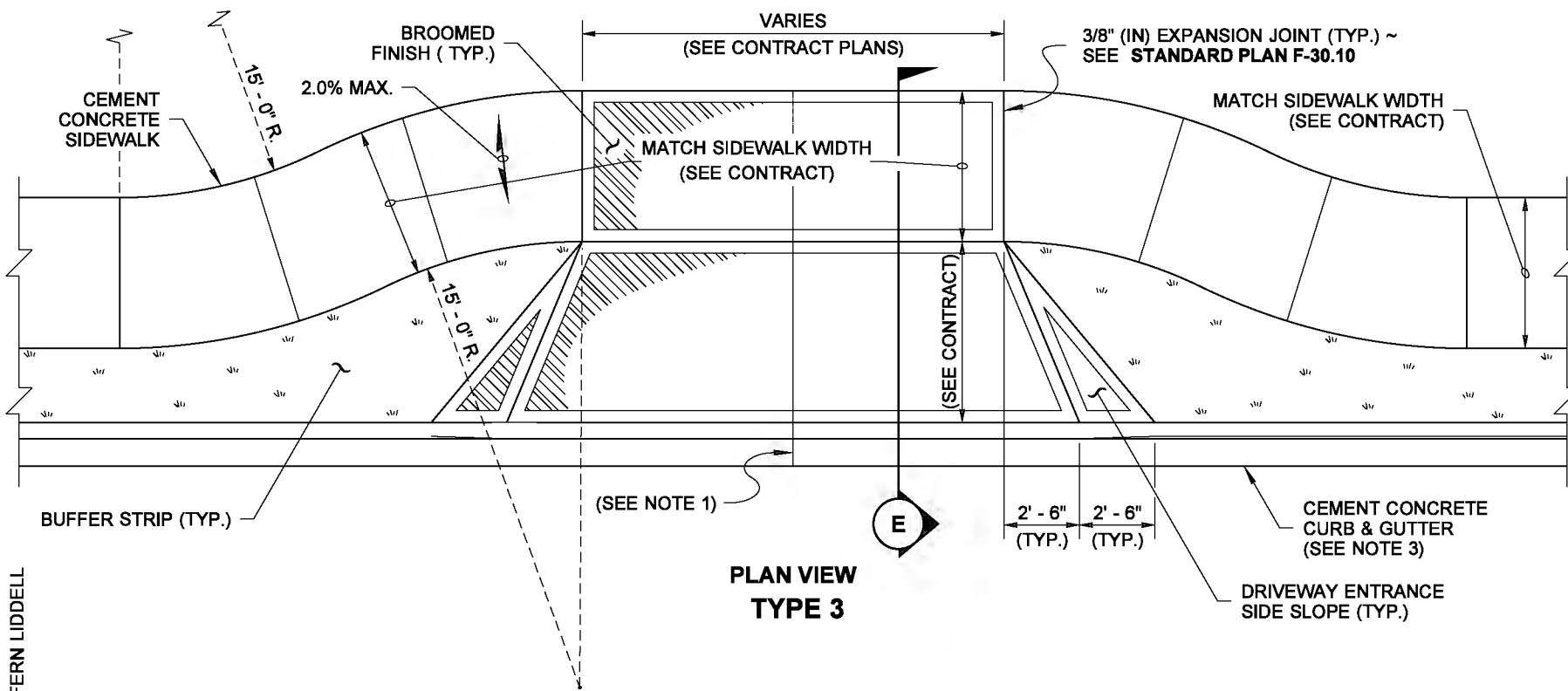

* THIS ENTRANCE TYPE SHALL NOT BE USED ALONG A PEDESTRIAN ROUTE

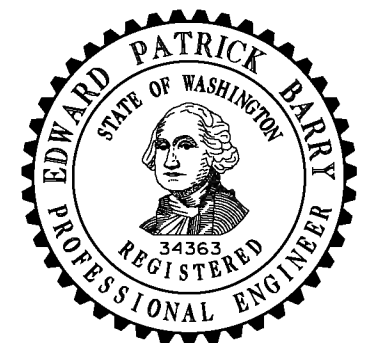
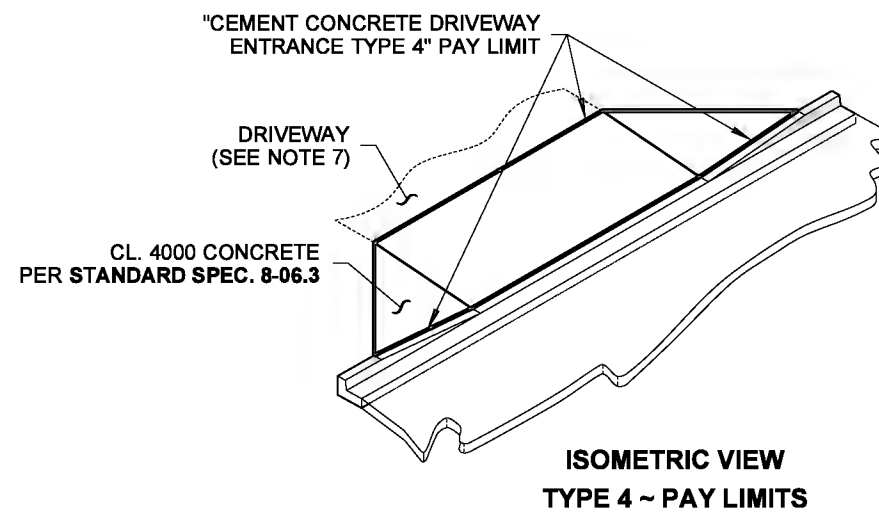
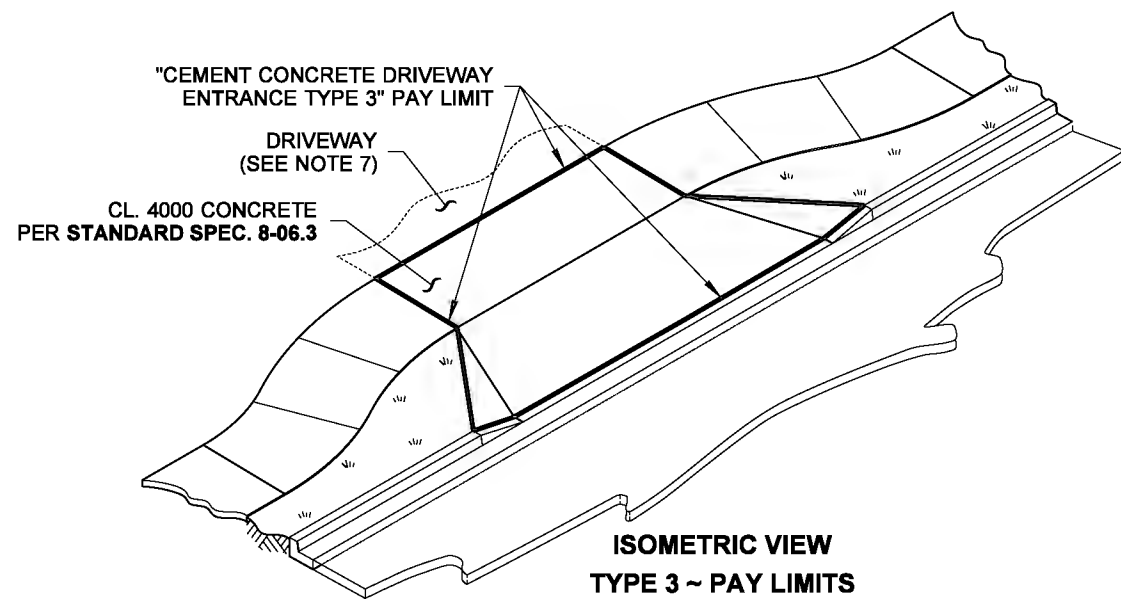
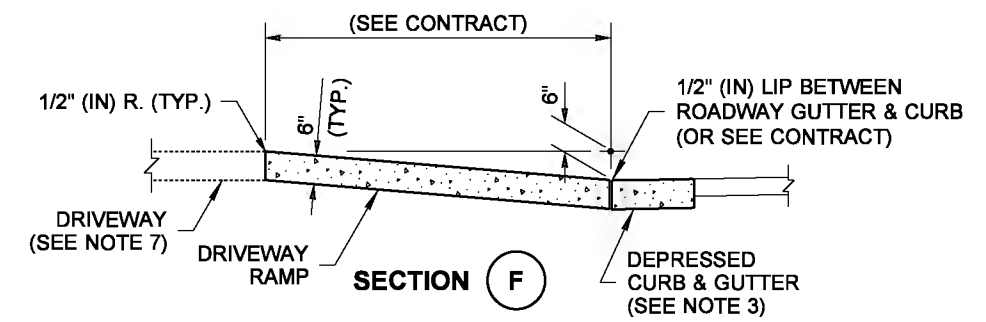
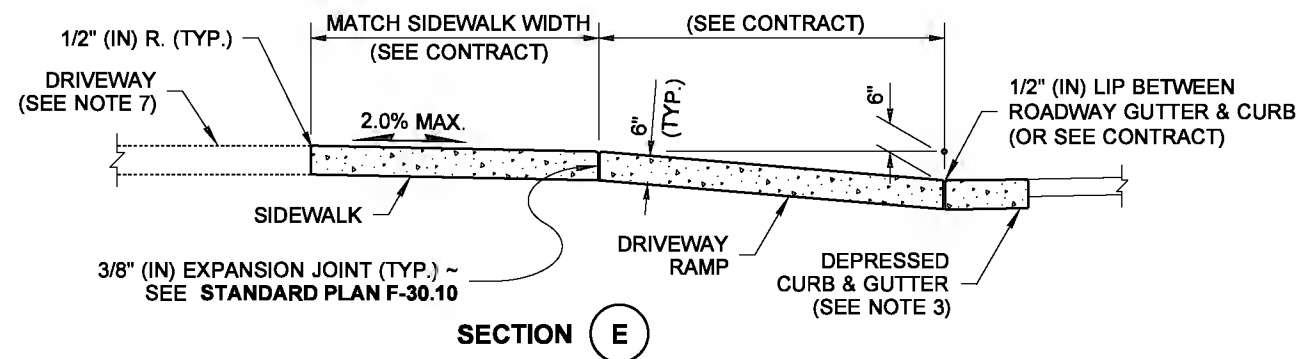

CEMENT CONCRETE DRIVEWAY ENTRANCE TYPES 1, 2, 3, & 4
STANDARD PLAN F-80.10-03

SHEET 2 OF 2 SHEETS

APPROVED FOR PUBLICATION

DRAWN BY: FERN LIDDELL

DRAWN BY: BILL BERENS

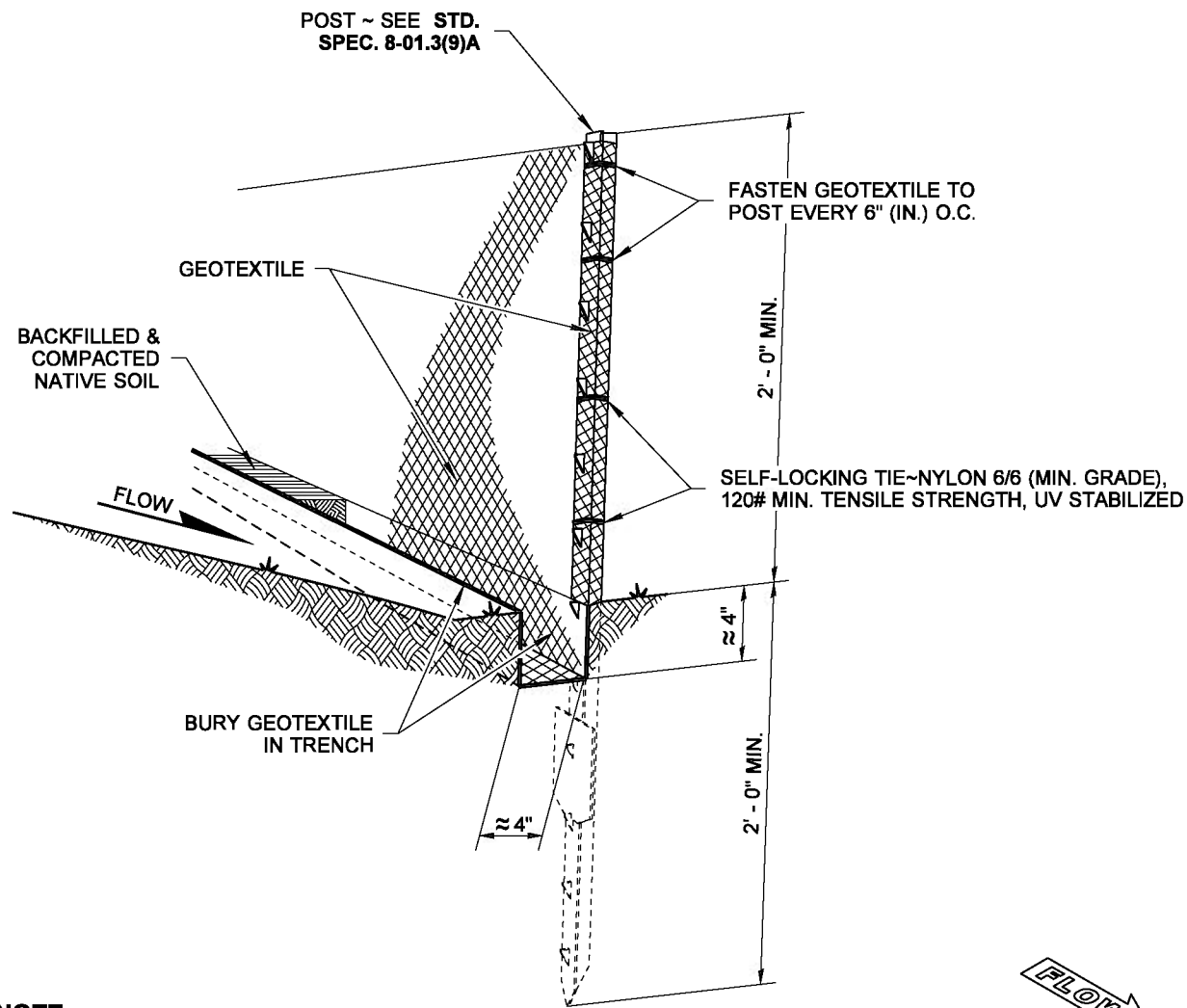

NOTE

DURING EXCAVATION, MINIMIZE DISTURBING THE GROUND AROUND TRENCH AS MUCH AS IS FEASIBLE, AND SMOOTH SURFACE FOLLOWING EXCAVATION TO AVOID CONCENTRATING FLOWS. COMPACTION MUST BE ADEQUATE TO PREVENT UNDERCUTTING FLOWS.

TYPICAL INSTALLATION DETAIL
(STEEL POSTS SHOWN)

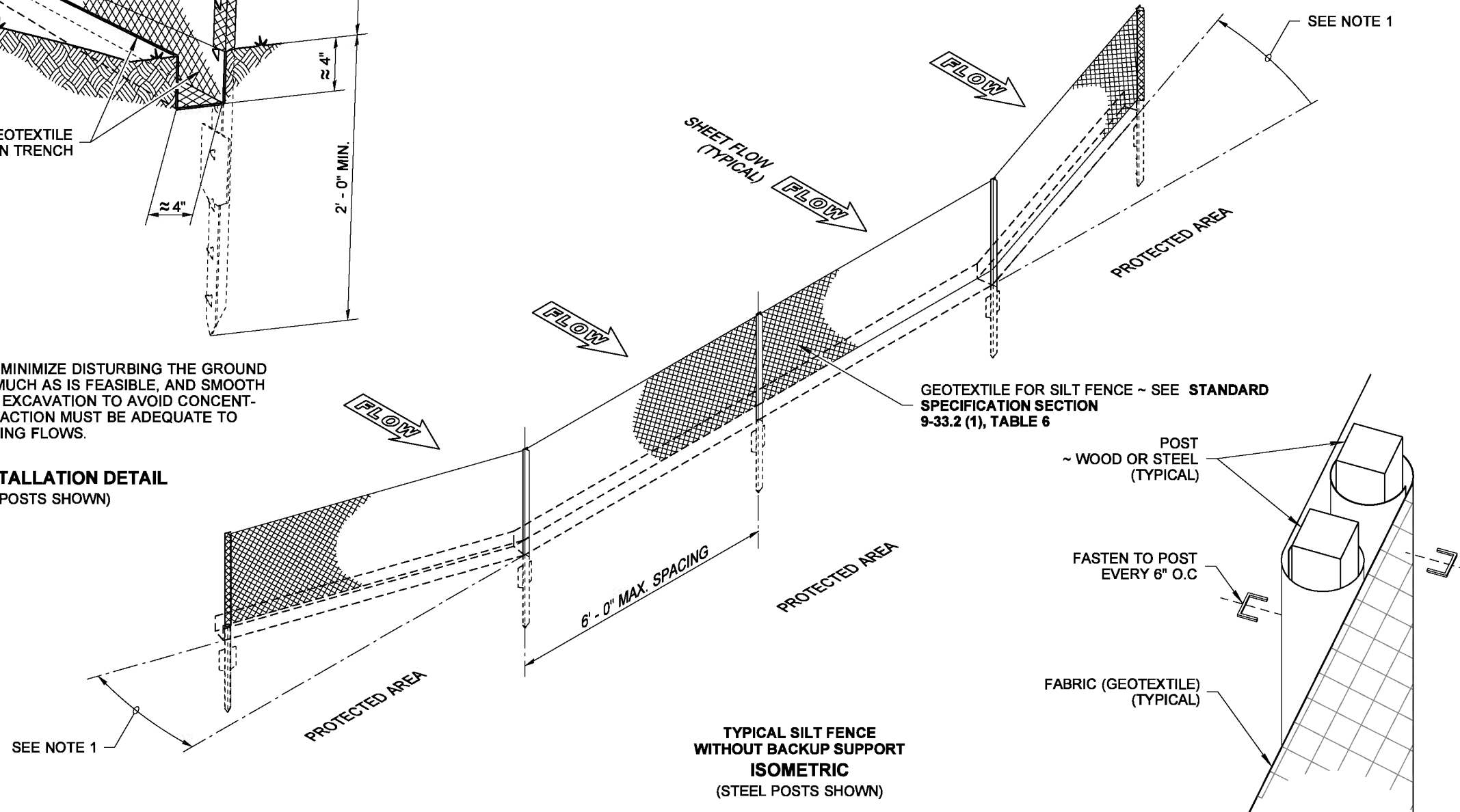

TYPICAL SILT FENCE WITHOUT BACKUP SUPPORT ISOMETRIC
(STEEL POSTS SHOWN)

SPLICED FENCE SECTIONS SHALL BE CLOSE ENOUGH TOGETHER TO PREVENT SILT LADEN WATER FROM ESCAPING THROUGH THE FENCE AT THE OVERLAP.

SPLICE DETAIL
(WOOD POSTS SHOWN)

NOTES

1. Install the ends of the silt fence to point slightly upslope to prevent sediment from flowing around the ends of the fence.
2. Perform maintenance in accordance with **Standard Specifications 8-01.3(9)A and 8-01.3(15)**.
3. Splices shall never be placed in low spots or sump locations. If splices are located in low or sump areas, the fence may need to be reinstalled unless the Project Engineer approves the installation.
4. Install silt fencing parallel to mapped contour lines.

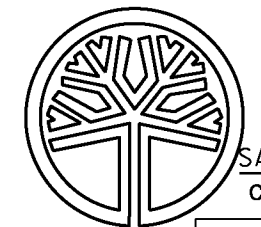

STATE OF WASHINGTON
REGISTERED
LANDSCAPE ARCHITECT

SANDRA L. SALISBURY
CERTIFICATE NO. 000860

NOTE: THIS PLAN IS NOT A LEGAL ENGINEERING DOCUMENT BUT AN ELECTRONIC DUPLICATE. THE ORIGINAL, SIGNED BY THE ENGINEER AND APPROVED FOR PUBLICATION, IS KEPT ON FILE AT THE WASHINGTON STATE DEPARTMENT OF TRANSPORTATION. A COPY MAY BE OBTAINED UPON REQUEST.

SILT FENCE

STANDARD PLAN I-30.15-02

SHEET 1 OF 1 SHEET

APPROVED FOR PUBLICATION

Pasco Bakotich III 3/22/13
STATE DESIGN ENGINEER DATE



Washington State Department of Transportation

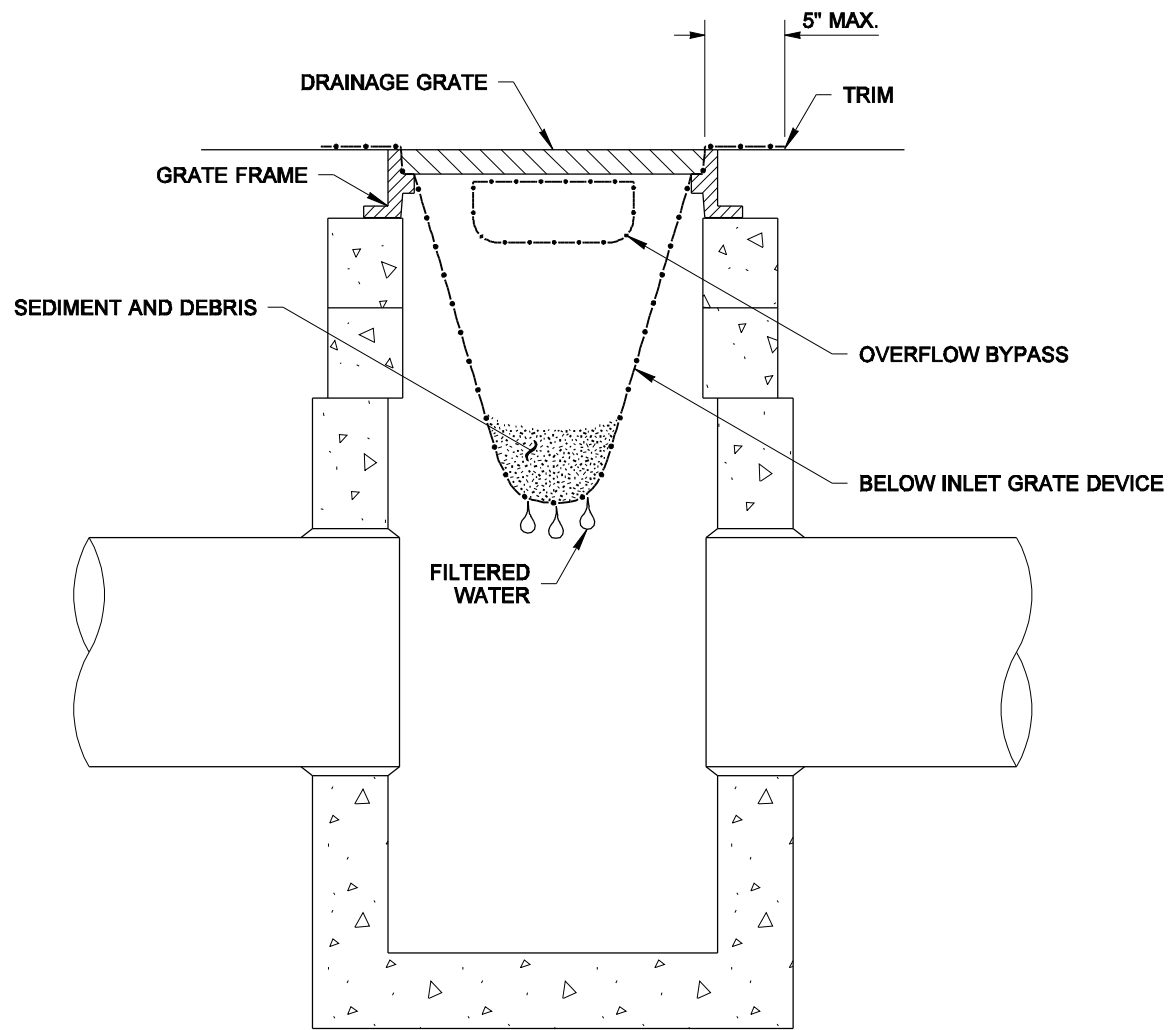

SECTION VIEW
NOT TO SCALE

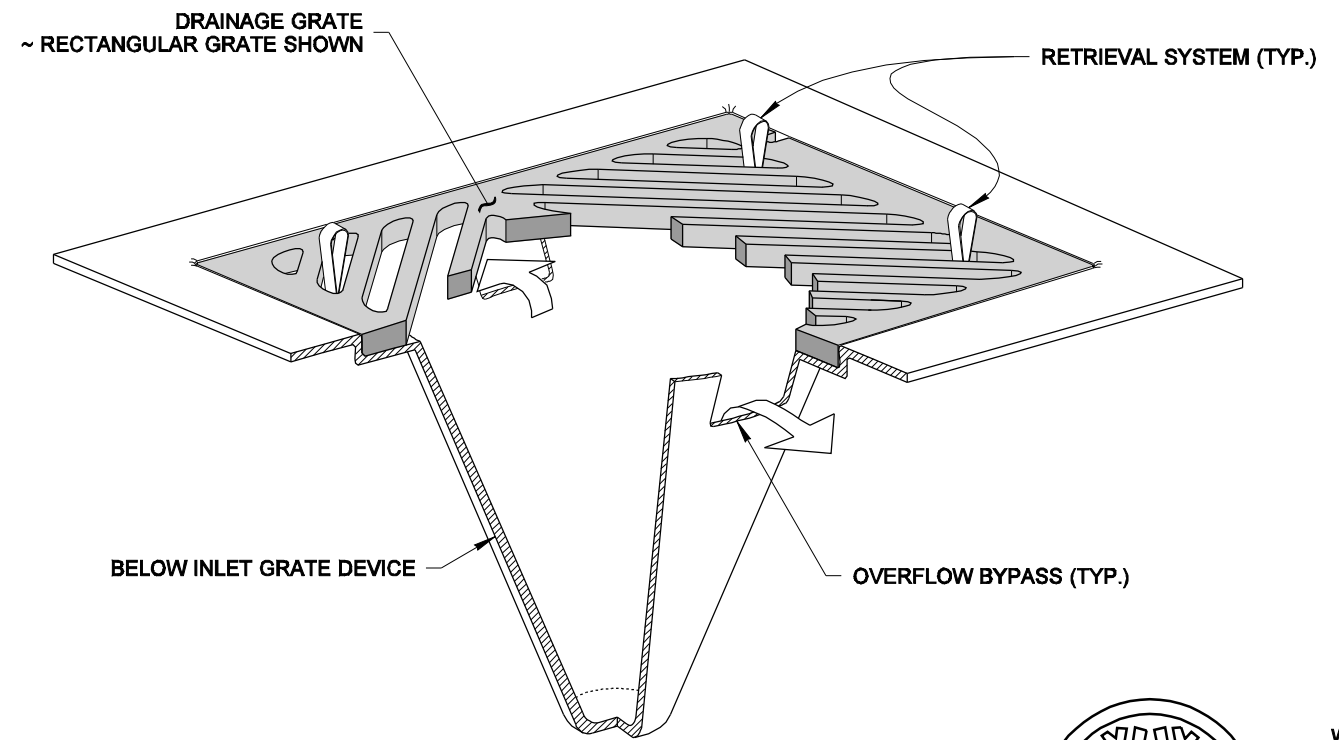

ISOMETRIC VIEW

NOTES

1. Size the Below Inlet Grate Device (BIGD) for the storm water structure it will service.
2. The BIGD shall have a built-in high-flow relief system (overflow bypass).
3. The retrieval system must allow removal of the BIGD without spilling the collected material.
4. Perform maintenance in accordance with Standard Specification 8-01.3(15).

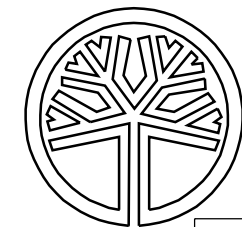

STATE OF WASHINGTON
REGISTERED
LANDSCAPE ARCHITECT

MARK W. MAURER
CERTIFICATE NO. 000598

NOTE: THIS PLAN IS NOT A LEGAL ENGINEERING DOCUMENT BUT AN ELECTRONIC DUPLICATE. THE ORIGINAL, SIGNED BY THE ENGINEER AND APPROVED FOR PUBLICATION, IS KEPT ON FILE AT THE WASHINGTON STATE DEPARTMENT OF TRANSPORTATION. A COPY MAY BE OBTAINED UPON REQUEST.

**STORM DRAIN
INLET PROTECTION
STANDARD PLAN I-40.20-00**

SHEET 1 OF 1 SHEET

APPROVED FOR PUBLICATION

Pasco Bakotich III **09-20-07**
STATE DESIGN ENGINEER DATE



GENERAL NOTES

200 AMP TYPE 120/240 1Ø SERVICE CABINET

1. SEE STD. SPECIFICATION 9-29.24, SERVICE CABINETS.
2. HINGES SHALL HAVE STAINLESS STEEL OR BRASS PINS.
3. CABINETS SHALL BE RATED NEMA 3R AND SHALL INCLUDE TWO RAIN TIGHT VENTS.
4. METERING EQUIPMENT DOOR SHALL BE PAD LOCKABLE. EACH DOOR SHALL BE GASKETED. INSTALL BEST CX CONSTRUCTION CORE ON BOTTOM DOOR. SEE DOOR HINGE DETAIL, STANDARD PLAN J-3b. CONCEALED HEAVY DUTY STAINLESS STEEL LIFT OFF HINGES ARE ALLOWED AS AN ALTERNATIVE TO DOOR HINGE DETAIL SHOWN ON STANDARD PLAN J-3b. UPPER DOOR SHALL HAVE 2 HINGES AND LOWER DOOR SHALL HAVE 3 HINGES. THE LOWER DOOR SHALL HAVE A TWO POSITION DOOR STOP ASSEMBLY.
5. THE FOLLOWING EQUIPMENT WITHIN THE SERVICE ENCLOSURE SHALL HAVE AN APPROPRIATELY ENGRAVED PHENOLIC NAME PLATE ATTACHED WITH SCREWS OR RIVETS: KEY NUMBERS 2, 3, 4, 6, 7, 8, 9, 16 AND 21. KEY NUMBER 4 NAME PLATE SHALL READ: "PHOTOCELL BYPASS TEST ON" AND "PHOTOCELL TEST OFF - AUTOMATIC". SEE SERVICE CABINET DETAIL.
6. METERING ARRANGEMENTS VARY WITH DIFFERENT SERVING UTILITIES. THE UTILITY MAY REQUIRE METER BASE MOUNTING IN THE ENCLOSURE, ON THE SIDE OR ON THE BACK OF THE ENCLOSURE. THE UTILITY MAY REQUIRE THE DIMENSION BETWEEN THE DOOR AND THE FRONT OF THE SAFETY SOCKET BOX TO BE LESS THAN THE 11 INCHES SHOWN IN THE LEFT SIDE- SAFETY SOCKET BOX MOUNTING DETAIL. SEE STANDARD PLAN J-3b FOR SAFETY SOCKET BOX DETAIL. THE CONTRACTOR SHALL VERIFY THE SERVING UTILITY'S REQUIREMENTS PRIOR TO FABRICATION OF AND INSTALLING THE SERVICE EQUIPMENT.
7. DIMENSIONS SHOWN ARE MINIMUM AND SHALL BE ADJUSTED TO ACCOMMODATE THE VARIOUS SIZES OF EQUIPMENT INSTALLED.
8. ALL BUSSWORK SHALL BE HIGH GRADE COPPER AND SHALL EQUAL OR EXCEED THE MAIN BREAKER RATING. ALL BREAKERS SHALL BOLT ONTO THE BUSSWORK. JUMPERING OF BREAKERS SHALL NOT BE ALLOWED. BUSSWORK SHALL ACCOMMODATE ALL FUTURE EQUIPMENT AS SHOWN IN THE BREAKER SCHEDULE.
9. THE PHOTOCELL UNIT SHALL BE CENTERED IN THE PHOTOCELL ENCLOSURE TO PERMIT 360 DEGREE ROTATION OF THE PHOTOCELL WITHOUT REMOVAL OF THE PHOTOCELL UNIT OR PHOTOCELL ENCLOSURE.
10. ALL INTERNAL WIRE RUNS SHALL BE IDENTIFIED WITH "TO - FROM" CODED TAGS LABELED WITH THE CODE LETTERS AND/OR NUMBERS SHOWN ON THE SCHEDULES. APPROVED PVC OR POLYOLEFIN WIRE MARKING SLEEVES SHALL BE USED.
11. ALL NUTS, BOLTS AND WASHERS USED FOR MOUNTING THE PHOTOCELL ENCLOSURE SHALL BE STAINLESS STEEL.
12. A 1% TOLERANCE IS ALLOWED FOR ALL DIMENSIONS.
13. THE PHOTOCELL CIRCUIT SHALL BE INSTALLED IN FLEX CONDUIT WITHIN THE METER COMPARTMENT.
14. INSTALL CONDUIT COUPLINGS ON ALL CONDUITS. PLACE COUPLINGS FLUSH WITH TOP OF CONCRETE FOUNDATION.
15. SEE PLANS FOR BREAKER SCHEDULE.
16. SEAL CABINET TO FOUNDATION WITH A 1/2" BEAD OF SILICONE. APPLY SILICONE TO DRY SURFACE ONLY.
17. THE METER BASE PORTION OF THIS SERVICE WAS DESIGNED TO MEET METERING PORTION OF EUSERC DRAWING 309 REQUIREMENTS.

- KEY**
- 1 METER BASE PER SERVING UTILITY REQUIREMENTS. AS A MINIMUM, THE METER BASE SHALL BE SAFETY SOCKET BOX WITH FACTORY INSTALLED TEST BYPASS FACILITY THAT MEETS THE REQUIREMENTS OF EUSERC DRAWING 305.
 - 2 MAIN BREAKER (SEE BREAKER SCHEDULE)
 - 3 PHOTOCELL BREAKER (SPST 15 AMP - 120/240 VOLT)
 - 4 TEST SWITCH (SPDT SNAP ACTION, POSITIVE CLOSE, 15 AMP - 120/277 VOLT "T" RATED)
 - 5 PHOTOELECTRIC CONTROL, STD. SPEC. 9 - 29.11(2)
 - 6 BRANCH BREAKER (SEE BREAKER SCHEDULE)
 - 7 SIGNAL BREAKER (SEE BREAKER SCHEDULE)
 - 8 CONTACTOR (SEE BREAKER SCHEDULE)
 - 9 RECEPTACLE BREAKER (SPST 20 AMP - 120/240 VOLT)
 - 10 RECEPTACLE, GROUNDED (GFCI 20 AMP - 125 VOLT)
 - 11 NEUTRAL BUSS, 14 LUG COPPER
 - 12 PHOTOCELL ENCLOSURE - ENCLOSURE TO BE FABRICATED FROM 5/8" EXPANDED STEEL MESH WITH WELDED SEAMS AND MOUNTING FLANGES. HOT DIP GALVANIZED AFTER FABRICATION. TYPE 5052 - H32 ALUMINUM WITH 5/8" x 5/8" OPENINGS EQUIVALENT TO 5/8" EXPANDED STEEL MESH MAY BE USED AS ALTERNATIVE MATERIAL. SEE PHOTOCELL ENCLOSURE MOUNTING DETAILS, STANDARD PLAN J-3b.
 - 13 HINGED FRONT FACING DOOR WITH 4" x 4" MIN. POLISHED WIRE GLASS WINDOW.
 - 14 HINGED DEAD FRONT WITH 1/4 TURN FASTENERS OR SLIDE LATCH.
 - 15 CABINET MAIN BONDING JUMPER. BUSS SHALL BE 4 LUG TINNED COPPER. SEE CABINET MAIN BONDING JUMPER DETAIL, STANDARD PLAN J-3b.
 - 16 SPARE BRANCH BREAKER (DPST 20AMP- 120/240 VOLT)
 - 17 METAL WIRING DIAGRAM HOLDER
 - 18 REMOVABLE EQUIPMENT MOUNTING PAN
 - 19 6" x 6" MIN. UNDERGROUND FEED - SERVICE WIREWAY (LEFT REAR CORNER)
 - 20 SCREENED VENTS, 2 REQUIRED, 1 EACH SIDE, LOUVERED PLATES.
 - 21 HEATER BREAKER (SPST 15 AMP - 120/240 VOLT)
 - 22 THERMOSTAT, 40°F CLOSURE - 3 DIFFERENTIAL
 - 23 STRIP HEATER (100 WATT NOMINAL), WITH TERMINAL STRIP COVER.
 - 24 24 CIRCUIT PANEL BOARD - MINIMUM SIZE WITH SEPARATE MAIN BREAKER.
 - 25 LABEL CABINET WITH BUSSWORK RATING.

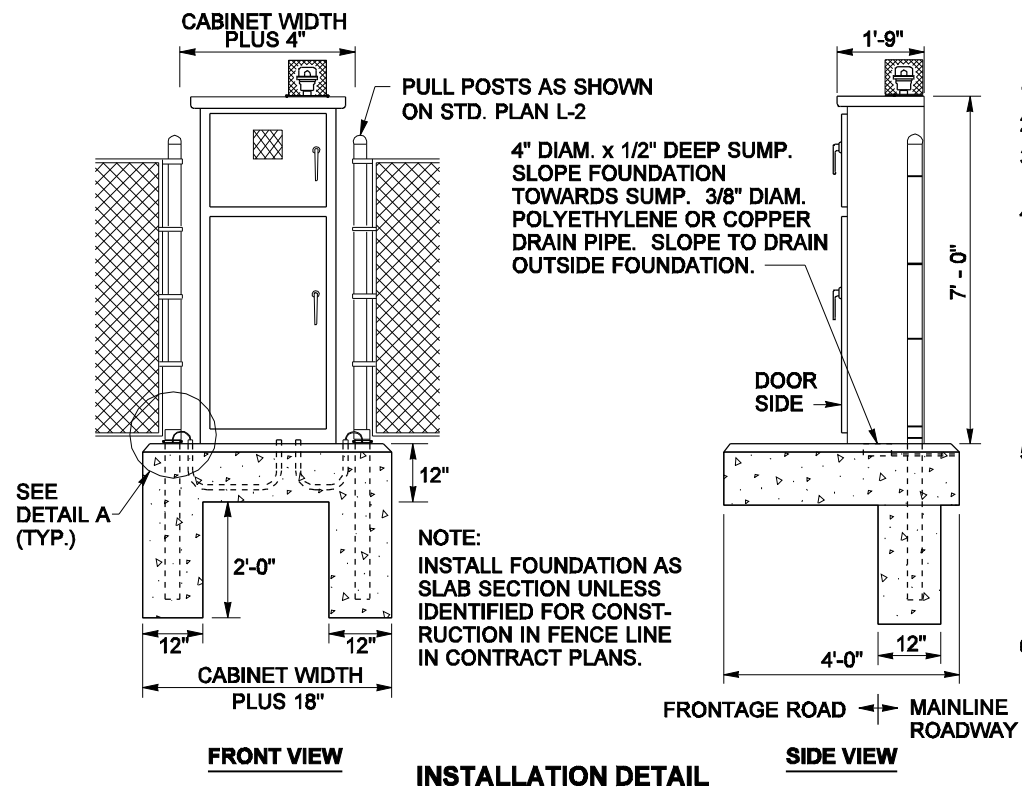

INSTALLATION DETAIL

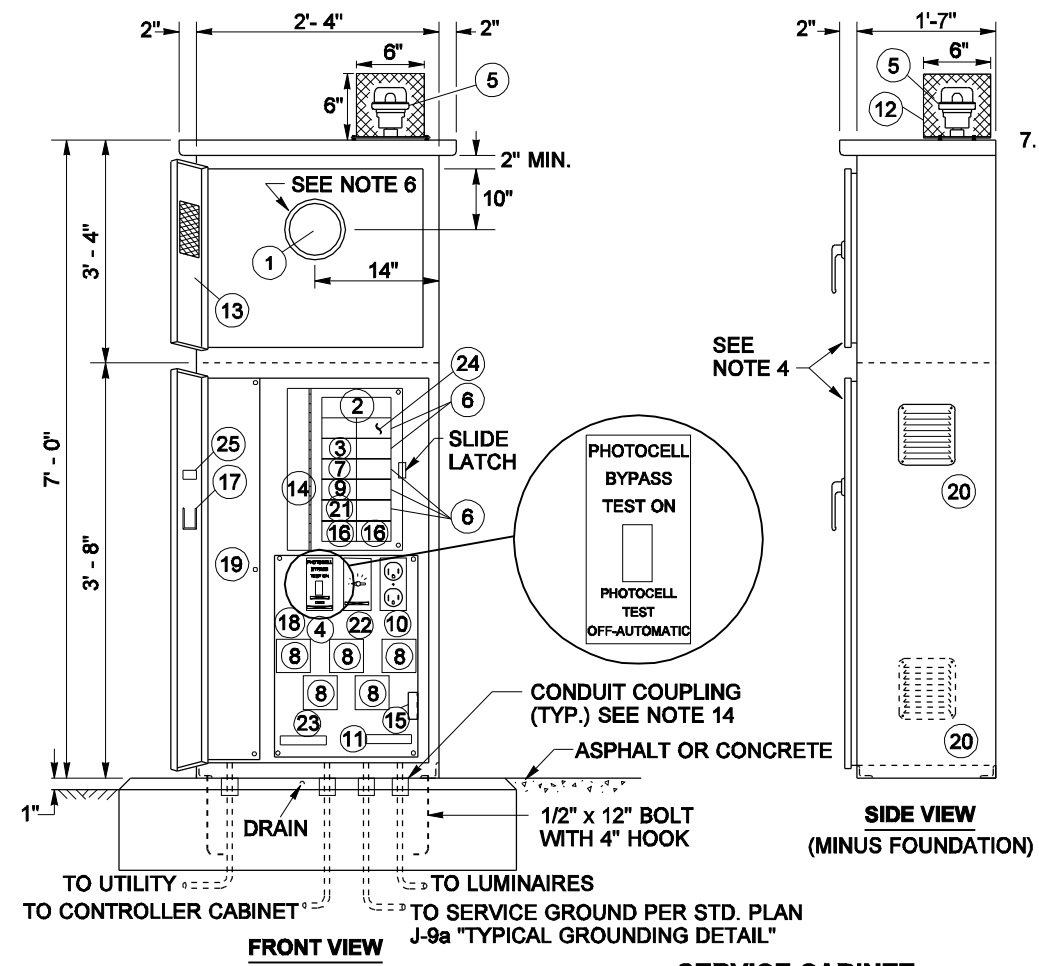

SERVICE CABINET

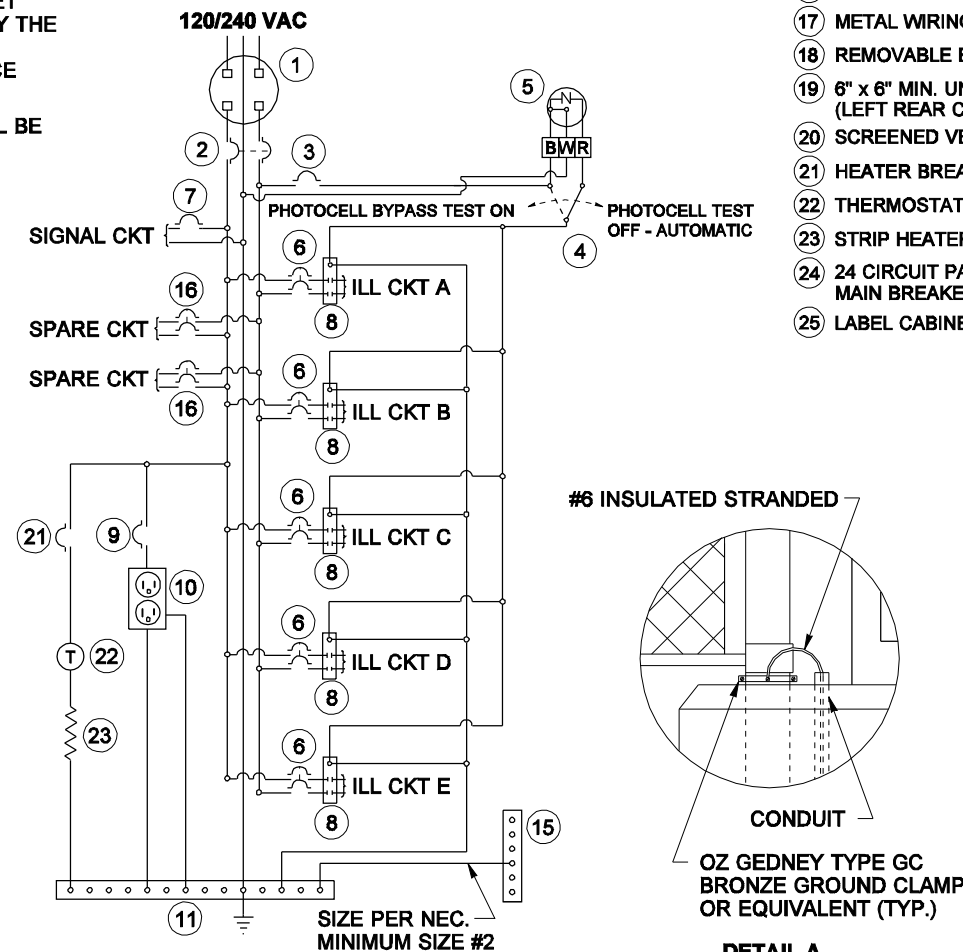

WIRING SCHEMATIC

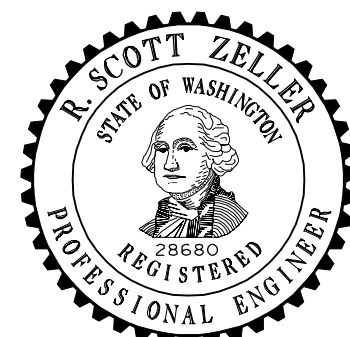

EXPIRES MAY 5, 2003

**SERVICE CABINET TYPE D
(0 - 200 AMP TYPE
120/240 SINGLE PHASE)
STANDARD PLAN J-3c**

SHEET 1 OF 1 SHEET

APPROVED FOR PUBLICATION

Harold J. Peterfeso 06-24-02
STATE DESIGN ENGINEER DATE



NOTE: THIS PLAN IS NOT A LEGAL ENGINEERING DOCUMENT BUT AN ELECTRONIC DIGITAL FILE. THE ORIGINAL, SIGNED BY THE ENGINEER AND APPROVED FOR PUBLICATION, IS KEPT ON FILE AT THE WASHINGTON STATE DEPARTMENT OF TRANSPORTATION. A COPY MAY BE OBTAINED UPON REQUEST.

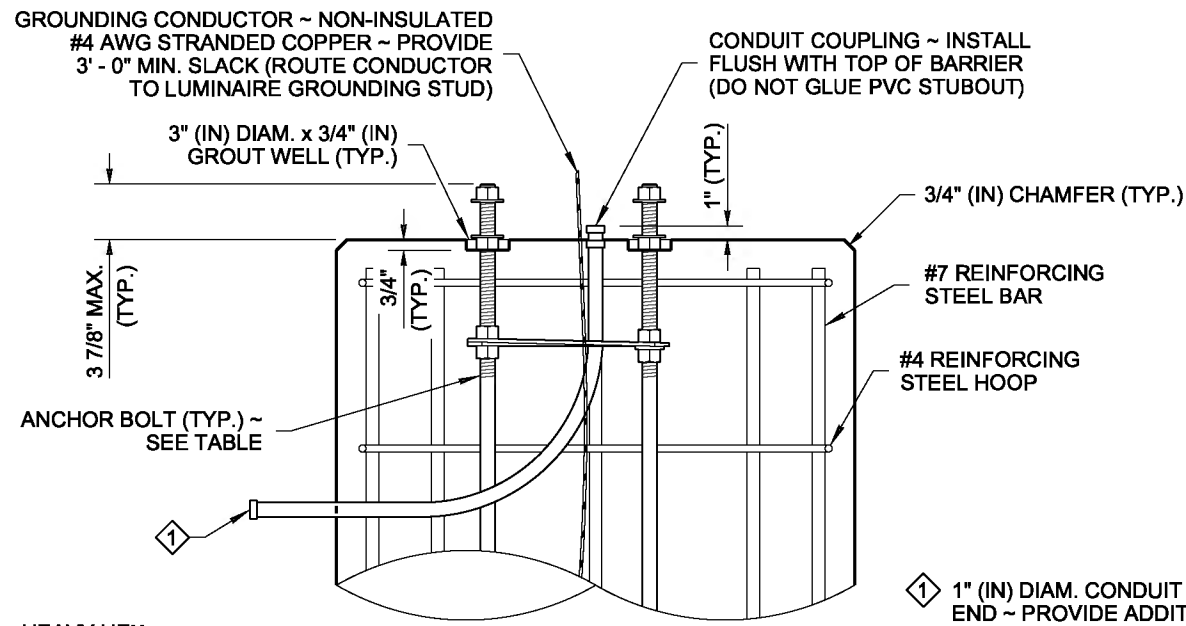

SEE FIXED BASE FOR DETAILS NOT SHOWN

PARTIAL ELEVATION VIEW
SLIP BASE

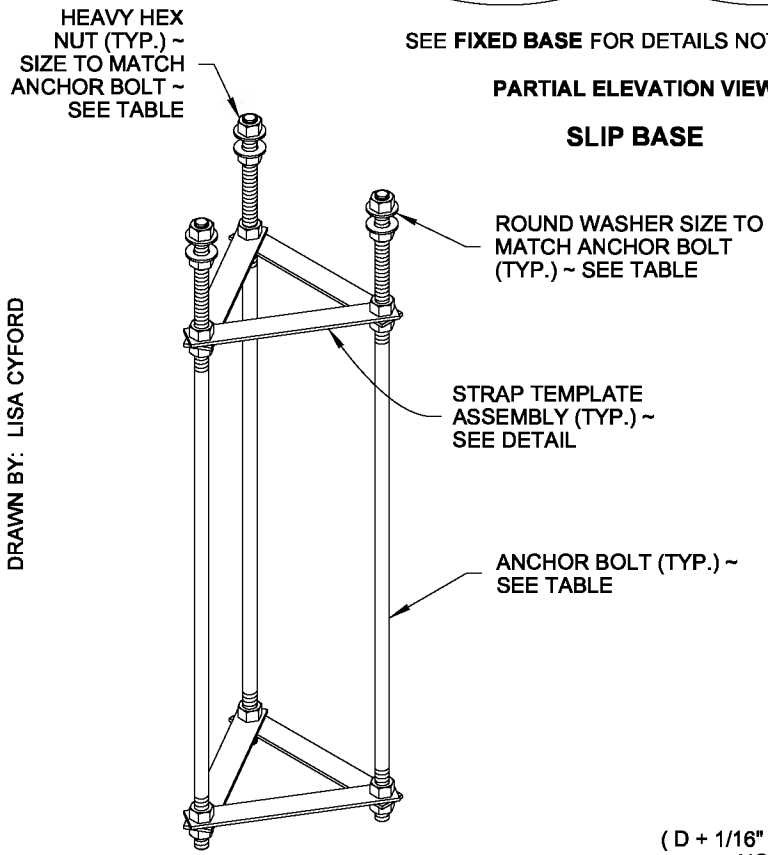

ISOMETRIC VIEW

ANCHOR BOLT ASSEMBLY
(SLIP BASE SHOWN)

ANCHOR BOLT TABLE			
LUMINAIRE HEIGHT (FT) (H1)	MAST ARM TYPE	MAST ARM LENGTH (FT)	ANCHOR BOLT DIAMETER (IN) "D"
20' TO 50'	SINGLE	6' TO 16'	1"
20' TO 50'	DOUBLE	6' TO 8'	1"
20' TO 45'	DOUBLE	10' TO 16'	1"
46' TO 50'	DOUBLE	10' TO 16'	1 1/8"

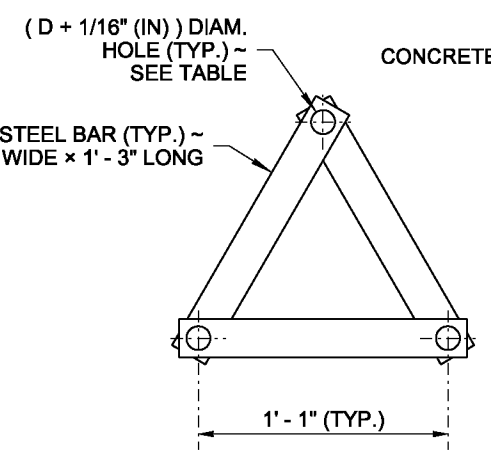

TOP VIEW
STRAP TEMPLATE ASSEMBLY

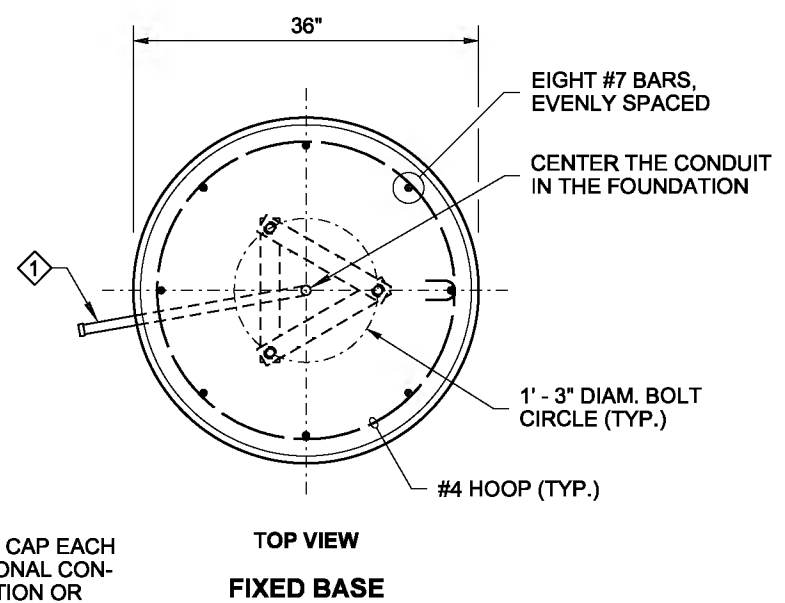

1" (IN) DIAM. CONDUIT ~ CAP EACH END ~ PROVIDE ADDITIONAL CONDUIT FOR COMMUNICATION OR SIGNAL CABLE WHERE SHOWN IN THE CONTRACT

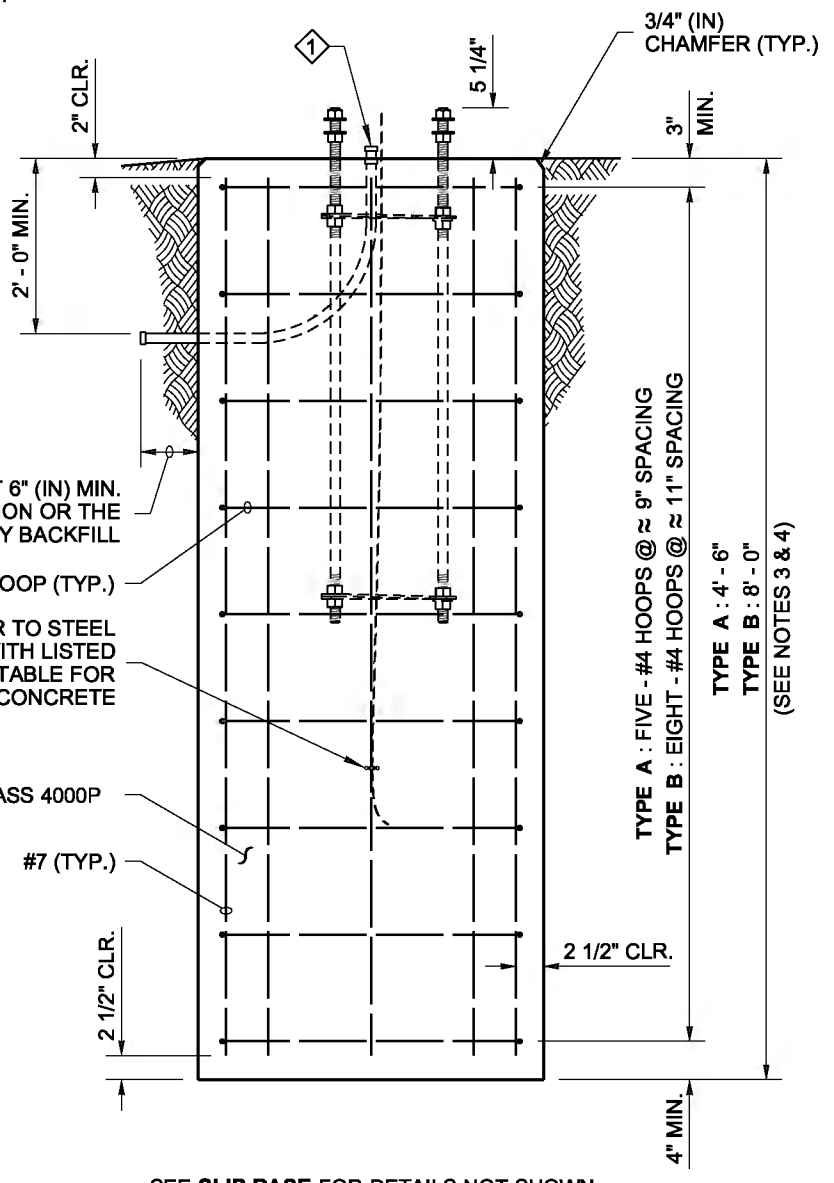

NOTES

- See **Standard Plan J-28.40** for Luminaire Pole base mounting details.
- The Strap Templates shall be held in place by nuts, 6" (in) from the top of the foundation and 3" (in) from the bottom of the anchor bolts. Eighteen heavy duty hex nuts and six round washers are required for a slip base assembly. Eighteen heavy duty hex nuts and six plate washers are required for a fixed base assembly.
- Use Steel Light Standard Foundation **Type A** on level ground or slopes not exceeding 4H : 1V. Use **Type B** for slopes steeper than 4H : 1V, but not exceeding 2H : 1V. Slopes steeper than 2H : 1V shall require a special design.
- These foundations are designed for a minimum of 2000 PSF (**TYPE A**) or 1500 PSF (**TYPE B**) allowable lateral bearing pressure for the soil. A special foundation shall be required for soil with allowable lateral bearing pressure lower than 1500 PSF.
- The Luminaire Pole height shall not exceed 50' (ft) (H1).
- Slip bases shall not be installed on 50' (ft) (H1) poles with Double Mast Arms, nor on poles weighing more than 1000 lbs.
- Slip bases are required on poles installed inside the Design Clear Zone, and on poles installed behind traffic barrier that are within the traffic barrier deflection zone.
- Foundations constructed within Media Filter Drains shall be increased in depth by the depth of the Media Filter Drain.
- Exposed portions of the foundation shall be formed to create a Class 2 surface finish. All forming shall be removed upon completion of foundation construction.
- For excavation, concrete placement, and backfill options, see METHOD 1 and METHOD 2 on Sheet 2 of 2.
- The anchor bolts shall be high-strength steel, manufactured from ASTM F1554 Grade 105, with heavy hex nuts and hardened washers. Galvanize the anchor bolts according to ASTM F2329.
- The foundation shall be grounded in accordance with the requirements of **Standard Specification 8-20.3(4)**.
- See **Standard Plans C-8b** and **C-85.14** for steel light standards on traffic barrier.

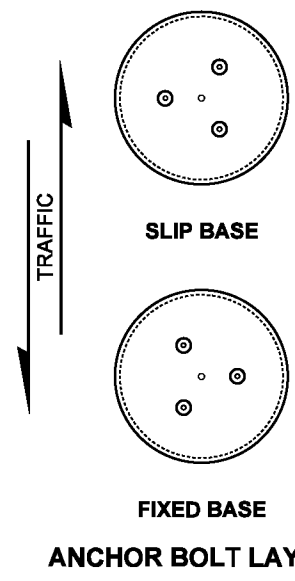

STEEL LIGHT STANDARD FOUNDATION TYPES A & B
STANDARD PLAN J-28.30-03

DRAWN BY: LISA CYFORD

DRAWN BY: LISA CYFORD

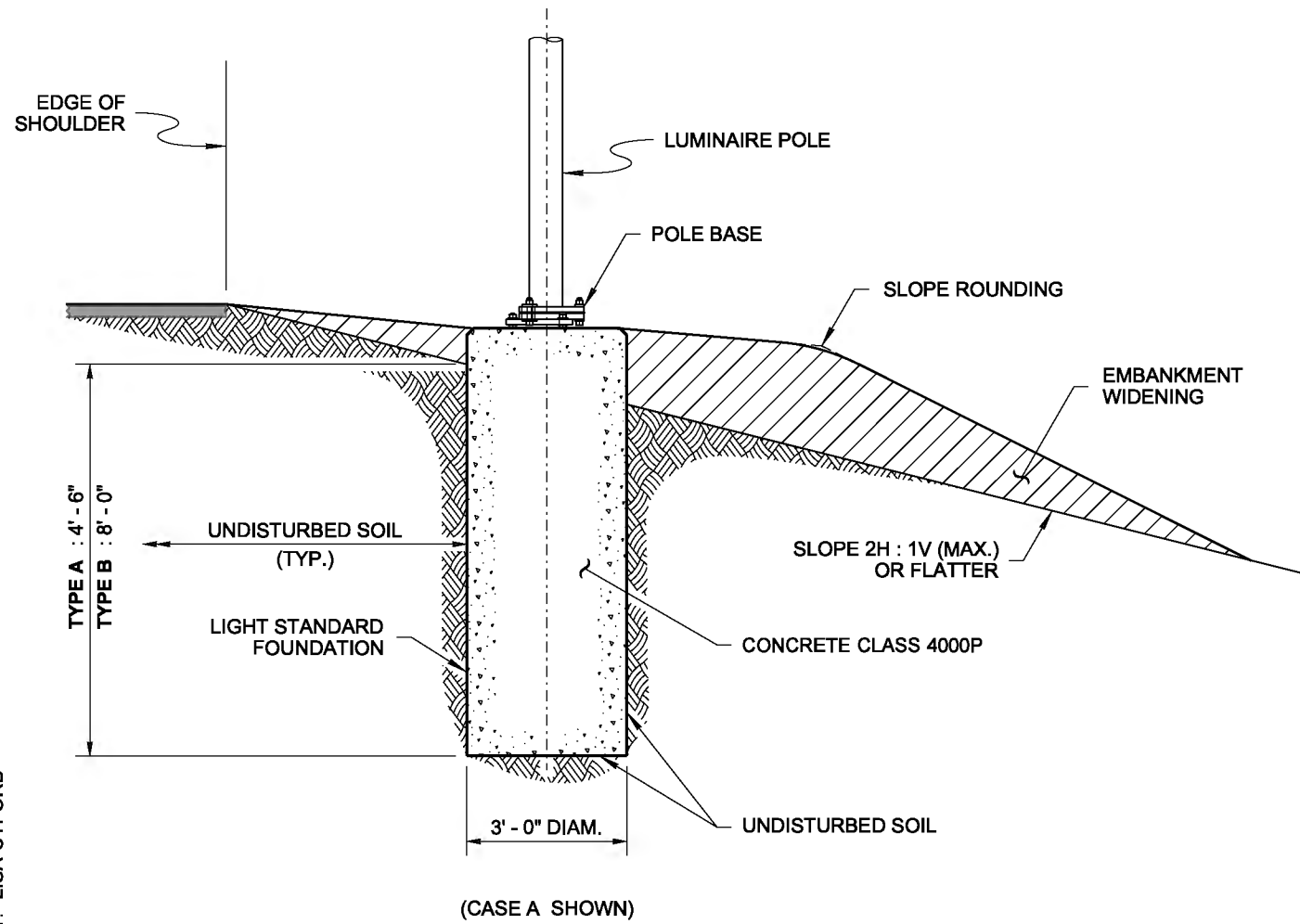

METHOD 1
NO SUBSURFACE FORM

This option is used only when the existing soil in the hole will remain standing and the cement concrete can be placed without causing the soil to collapse. Concrete shall be cast directly against undisturbed soil.

Auger the hole for the foundation. Use a paper or cardboard form to achieve a smooth finish on the final exposed cement concrete. Support the form as necessary to remain plumb.

See **Standard Plans J-28.24** and **J-28.26** for maximum heights of exposed foundation when no embankment widening is to be installed.

Place the concrete foundation.

After concrete has cured, remove the paper or cardboard form portion.

Construct the embankment widening (if required).

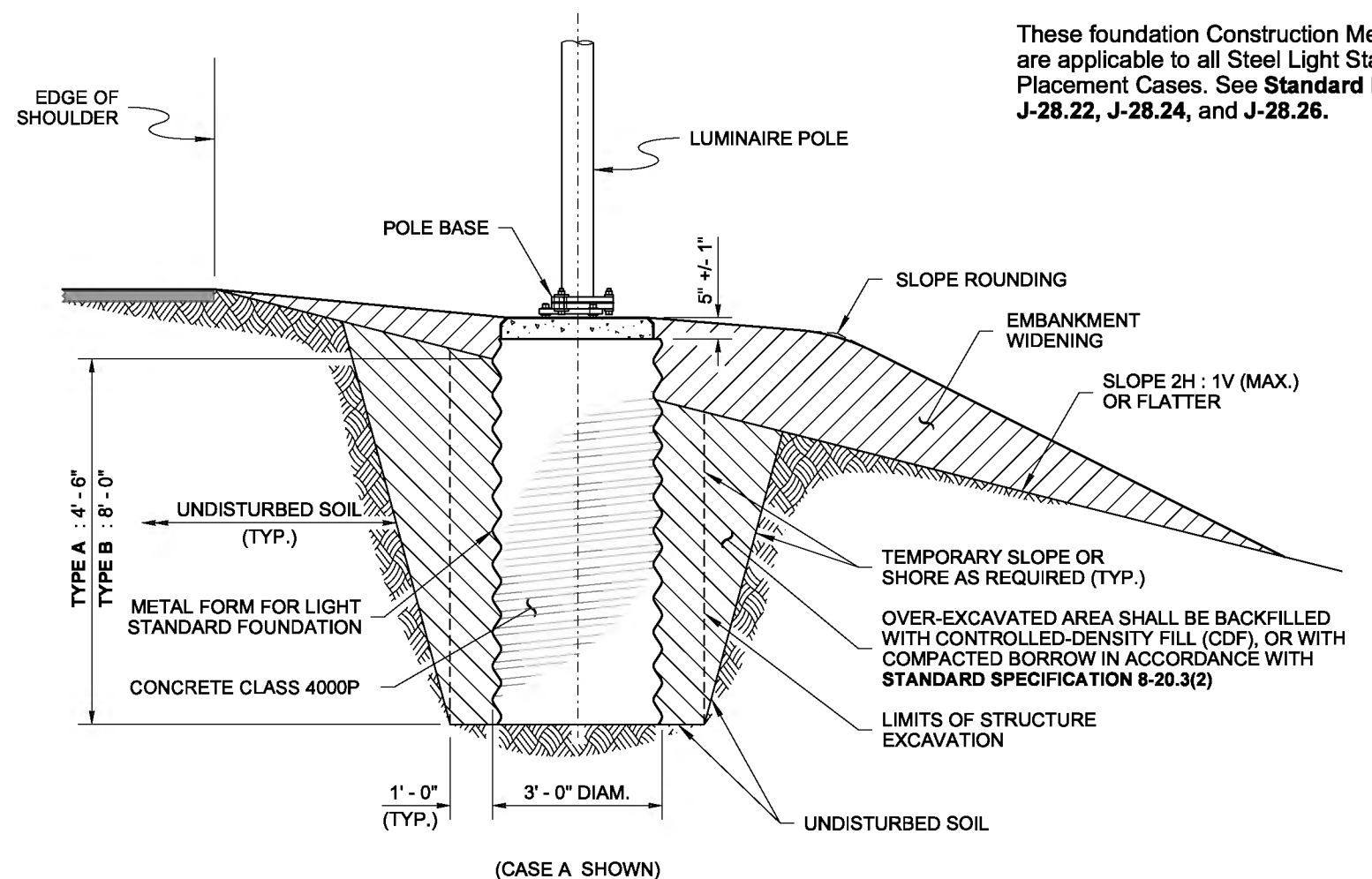

METHOD 2
METAL (SUBSURFACE) FORM REQUIRED

When the existing soil will not retain a vertical face, over-excavate the foundation area and install a 36" (in) diameter corrugated metal (pipe) form. The corrugated metal form shall not extend more than 5" (in) +/- 1" (in) below any portion of the foundation that will remain exposed upon final grading. Continue forming to full height using a paper or cardboard form to achieve a smooth finish on final exposed cement concrete. Support the form as necessary to remain plumb.

See **Standard Plans J-28.24** and **J-28.26** for maximum heights of exposed foundation when no embankment widening is to be installed.

Place the concrete foundation.

After concrete has cured, remove the paper or cardboard form portion.

Backfill with controlled-density fill or compacted borrow in accordance with **Standard Specification 8-20.3(2)**.

Construct the embankment widening (if required).

NOTE

These foundation Construction Methods are applicable to all Steel Light Standard Placement Cases. See **Standard Plans J-28.22, J-28.24, and J-28.26**.

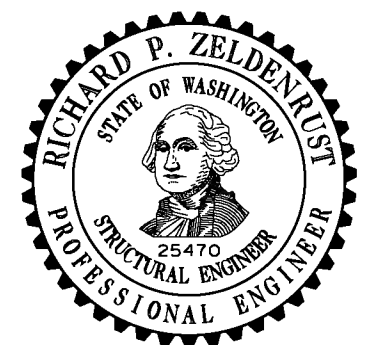

STEEL LIGHT STANDARD FOUNDATION TYPES A & B

STANDARD PLAN J-28.30-03

SHEET 2 OF 2 SHEETS

APPROVED FOR PUBLICATION

STATE DESIGN ENGINEER
Washington State Department of Transportation

CONSTRUCTION METHODS

DRAWN BY: LISA CYFORD

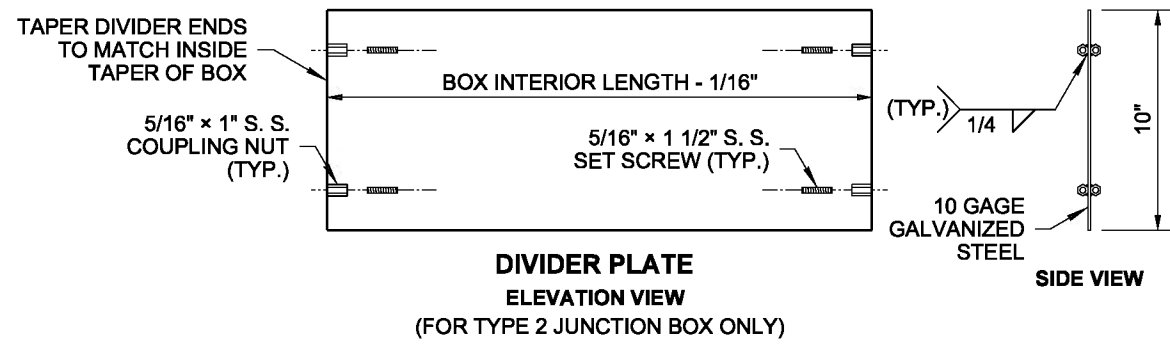

JUNCTION BOX DIMENSION TABLE			
MARK	ITEM	BOX TYPE	
		TYPE 1	TYPE 2
A	OUTSIDE LENGTH OF JUNCTION BOX	22"	33"
B	OUTSIDE WIDTH OF JUNCTION BOX	17"	22 1/2"
C	INSIDE LENGTH OF JUNCTION BOX	18" ~ 19"	28" ~ 29"
D	INSIDE WIDTH OF JUNCTION BOX	13" ~ 14"	17" ~ 18"
E	LID LENGTH	17 5/8"	28 5/8"
F	LID WIDTH	12 5/8"	18 1/8"
CAPACITY ~ CONDUIT DIAMETER		6"	12"

NOTES

- All box dimensions are approximate. Exact configurations vary among manufacturers.
- Minimum lid thickness shown. The diamond pattern shall be a minimum of 28% of the overall thickness. Junction Boxes installed in sidewalks, walkways, and shared-use paths shall have a slip-resistant coating on the lid and lip cover plate, and shall be installed with the surface flush with and matched to the grade of the sidewalk, walkway, or shared-use path. The non-slip lid shall be identified with permanent markings on the underside, indicating the type of surface treatment (see Contract Documents for details) and the year of manufacture. The permanent marking shall be 1/8" inch line thickness formed with a stainless steel weld bead and shall be placed prior to hot-dip galvanizing.
- Lid support members shall be 3/16" minimum thick steel C, L, or T shape, welded to the frame.
- A 1/4-20 NC x 3/4" stainless steel ground stud shall be welded to the bottom of the lid; include (2) stainless steel nuts and (2) stainless steel flat washers.
- Bolts and nuts shall be liberally coated with anti-seize compound.
- Equipment Bonding Jumper shall be # 8 AWG min. x 4' of tinned braided copper.
- The System Identification letters shall be 1/8" line thickness formed by engraving, stamping, or with a S. S. weld bead. See Cover Marking detail. Grind off diamond pattern before forming letters. For System Identification details, see **Standard Specification 9-29.2(4)**.
- When required in the Contract, provide a 10" x 27 1/2", 10 gage divider plate, complete, with fasteners, in each Type 2 Junction Box where specified.
- When required in Contract, provide a 12" deep extension for each Type 2 Junction Box where specified.
- See the Standard Specifications for alternative reinforcement and class of concrete.
- Headed Anchor Shear Studs must be welded to the Steel Cover Lip Plate and wire tied in two places to the vertical Welded Reinforcement Wire when in contact with each other. Wire tie all other Headed Anchor Shear Studs to the horizontal Welded Reinforcement Wire.
- Lid Bolt Down Attachment Tab provides a method of retrofitting by using a mechanical process in lieu of welding. Attachment Tab shown depicts a typical component arrangement; actual configurations of assembly will vary among manufacturers. See approved manufacturers' shop drawings for specifics.
- Unless otherwise noted in the plans or approved by the Engineer, Junction Boxes, Cable Vaults, and Pull Boxes shall not be placed within the sidewalks, walkways, shared use paths, traveled ways or paved shoulders. All Junction Boxes, Cable Vaults, and Pull Boxes placed within the traveled way or paved shoulders shall be Heavy-Duty.
- Distance between the top of the conduit and the bottom of the Junction Box lid shall be 6" min. to 8" max. for final grade of new construction only. See **Standard Specification 8-20.3(5)**. Where adjustments are to be made to existing Junction Boxes, or for interim construction stages during the contract, the limits shall be from 6" min. to 10" max. See **Standard Specification 8-20.3(6)**.

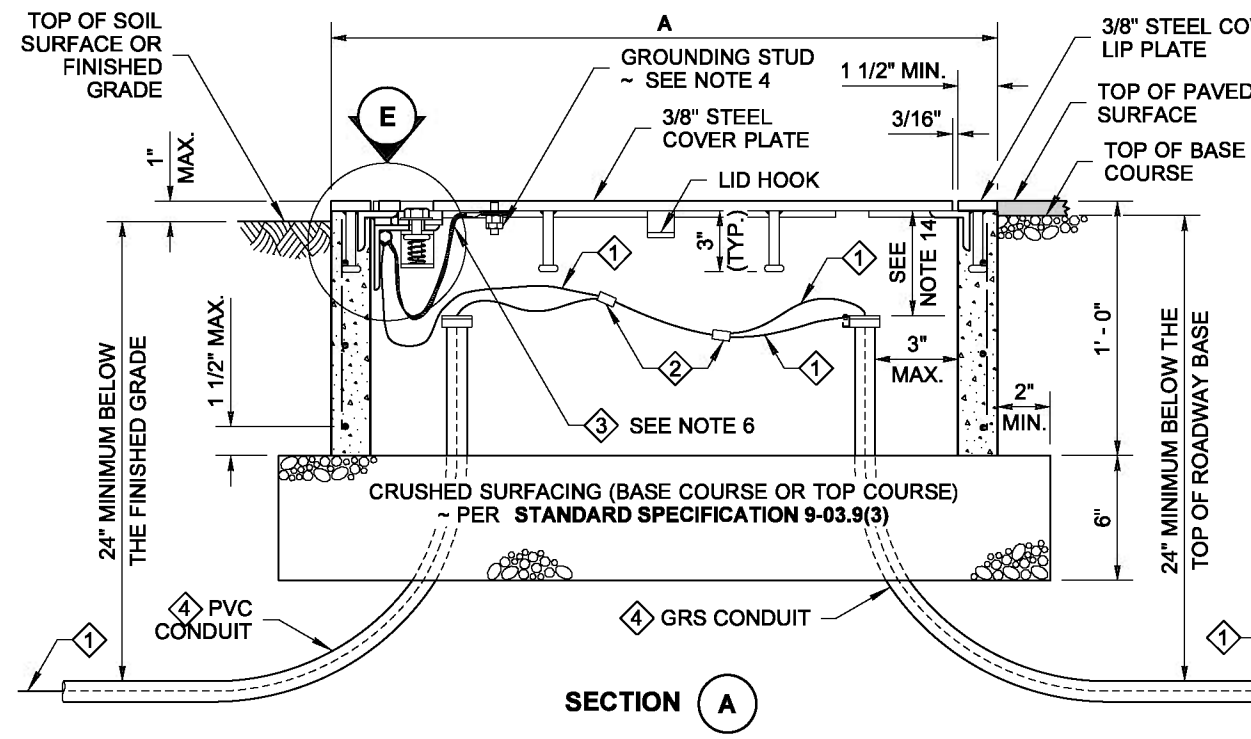
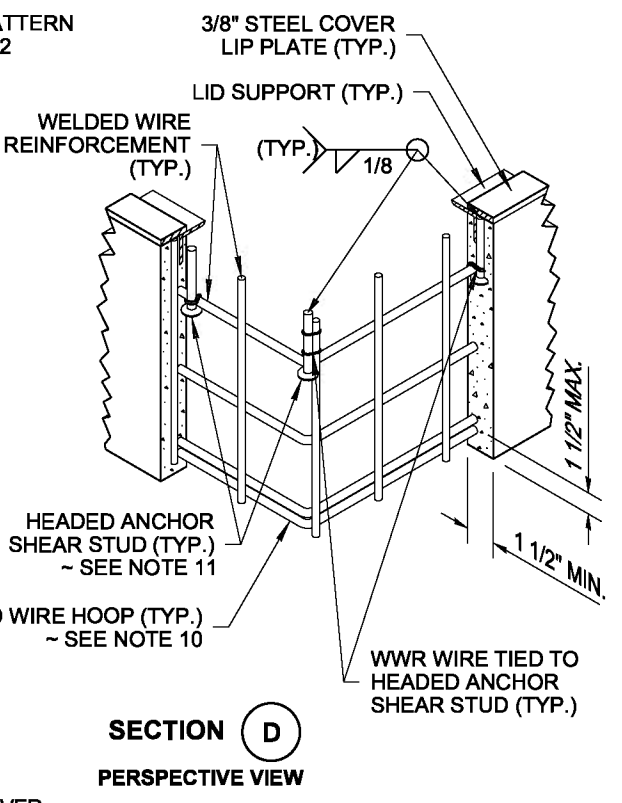
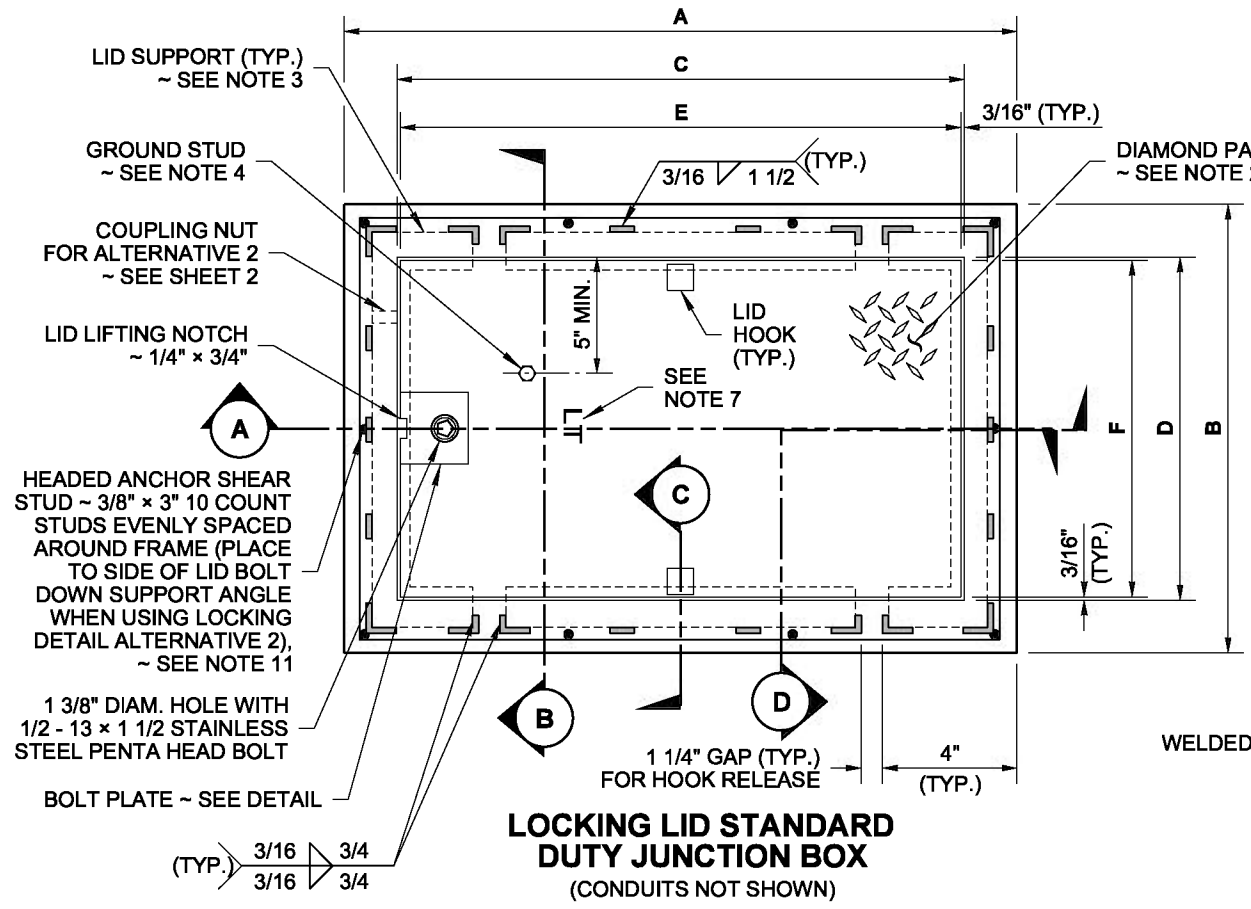

- Equipment Grounding Conductor
- Copper Solderless Crimp Connector
- Equipment Bonding Jumper ~ see note 6
- See Contract for conduit size and number

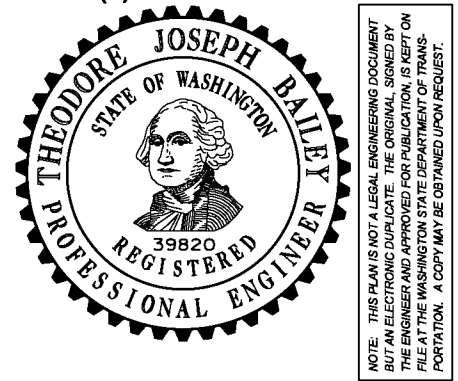
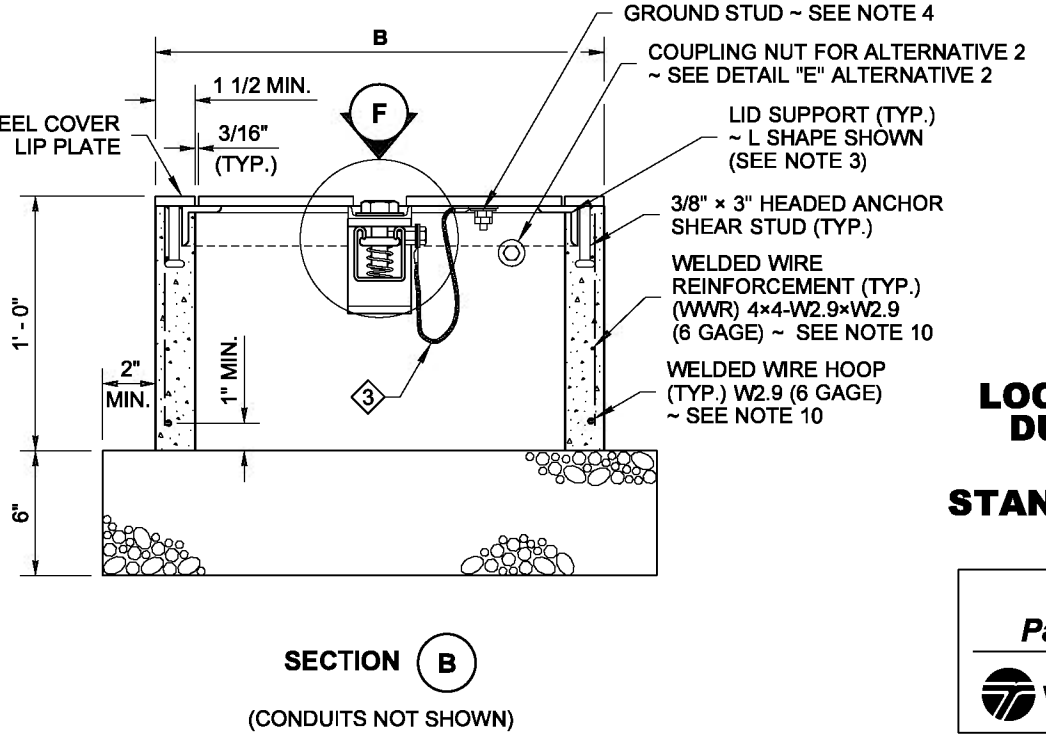
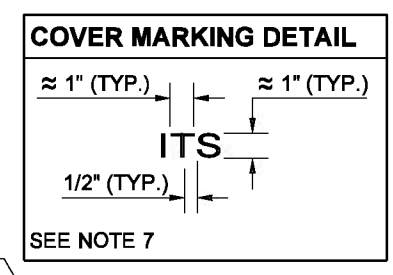

**LOCKING LID STANDARD
DUTY JUNCTION BOX
TYPES 1 & 2
STANDARD PLAN J-40.10-03**

SHEET 1 OF 2 SHEETS

APPROVED FOR PUBLICATION

Pasco Bakotich III 5/20/13
STATE DESIGN ENGINEER DATE

Washington State Department of Transportation

NOTE: THIS PLAN IS NOT A LEGAL ENGINEERING DOCUMENT UNTIL ELECTRONICALLY SIGNED BY THE ENGINEER AND APPROVED FOR PUBLICATION IS FILED AT THE WASHINGTON STATE DEPARTMENT OF TRANSPORTATION. A COPY MAY BE OBTAINED UPON REQUEST.

DRAWN BY: LISA CYFORD

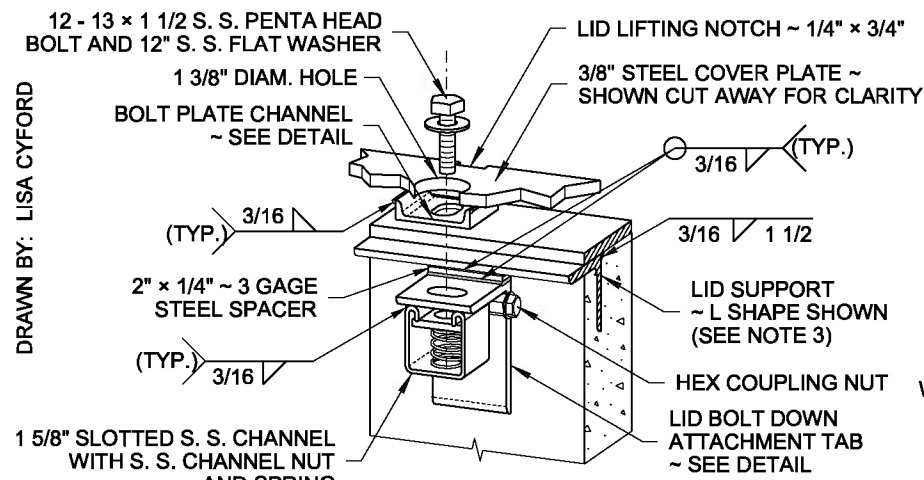

DETAIL F

ALTERNATIVE 1 SHOWN PERSPECTIVE VIEW

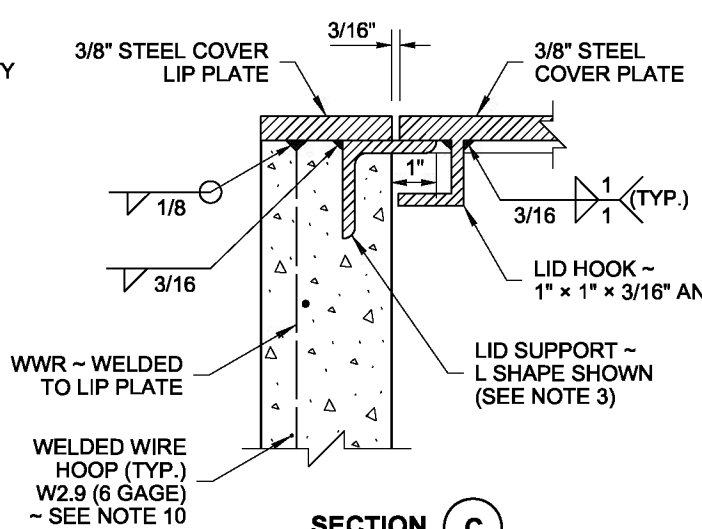

SECTION C

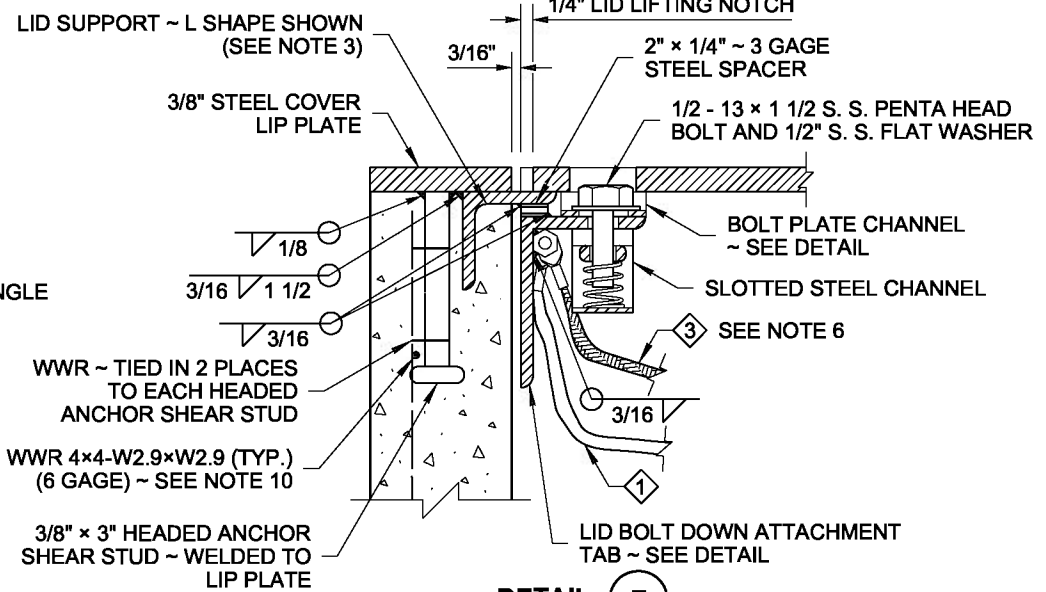

DETAIL E

ALTERNATIVE 1 SHOWN

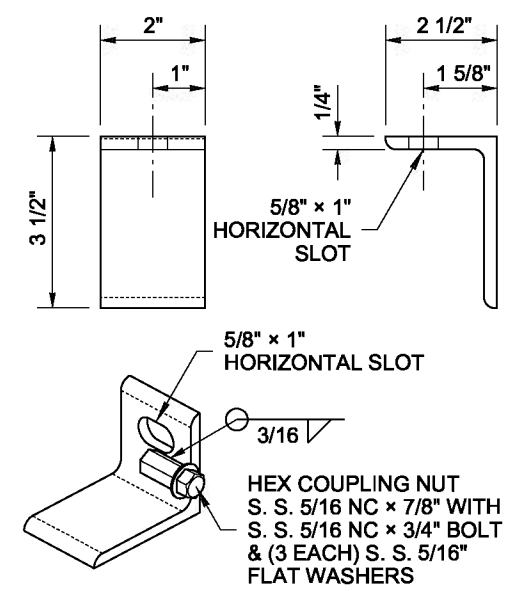

ALTERNATIVE 1 LID BOLT DOWN ATTACHMENT TAB (SEE NOTE 12)

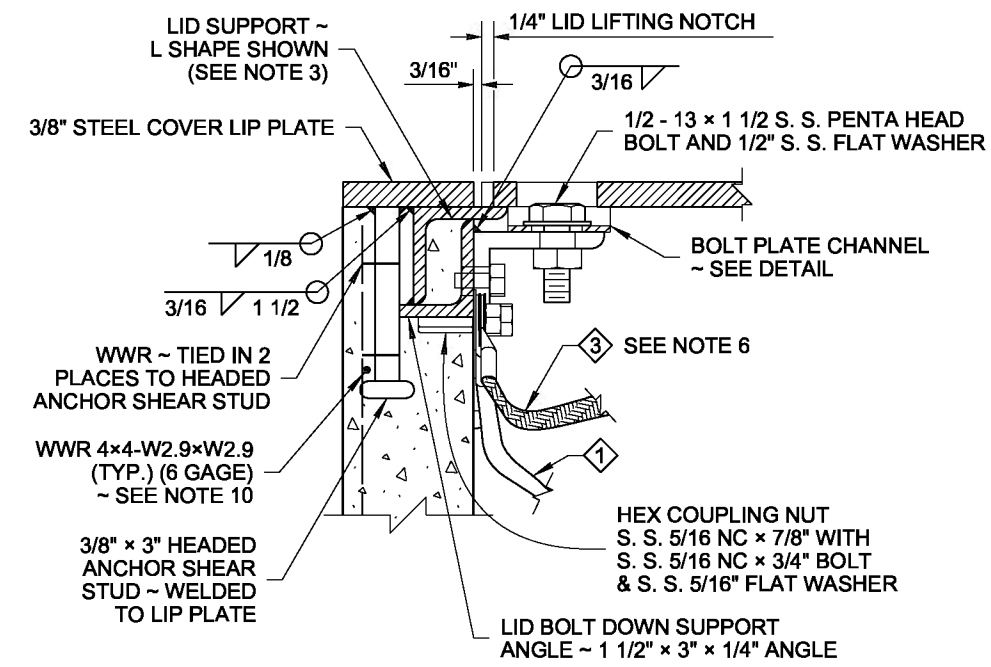

DETAIL E

ALTERNATIVE 2 SHOWN

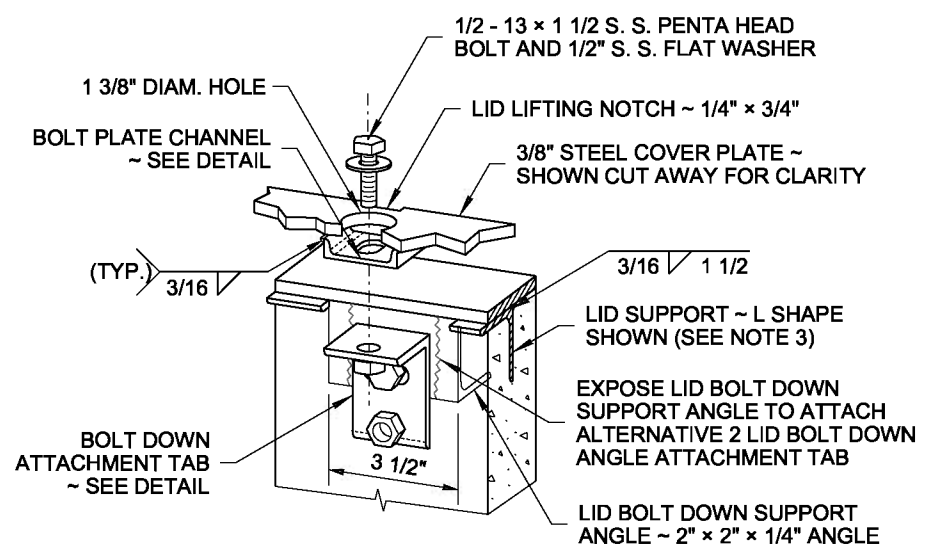

DETAIL F

ALTERNATIVE 2 SHOWN PERSPECTIVE VIEW

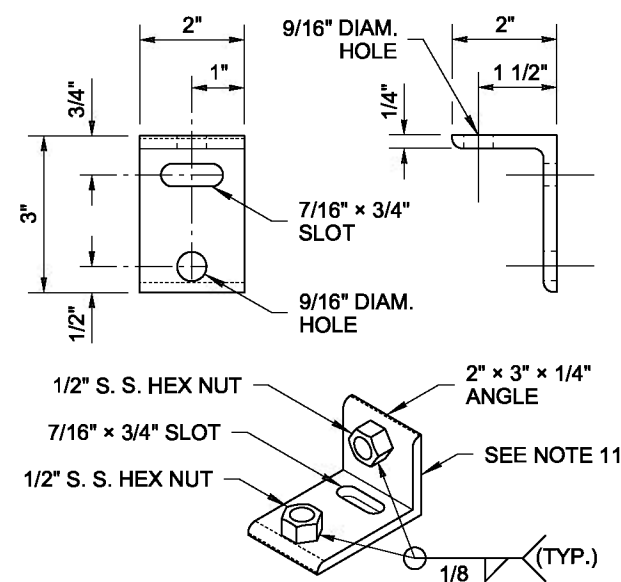

ALTERNATIVE 2 LID BOLT DOWN ATTACHMENT TAB (SEE NOTE 12)

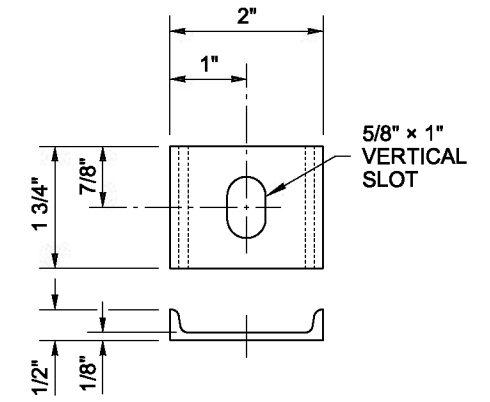

BOLT PLATE CHANNEL

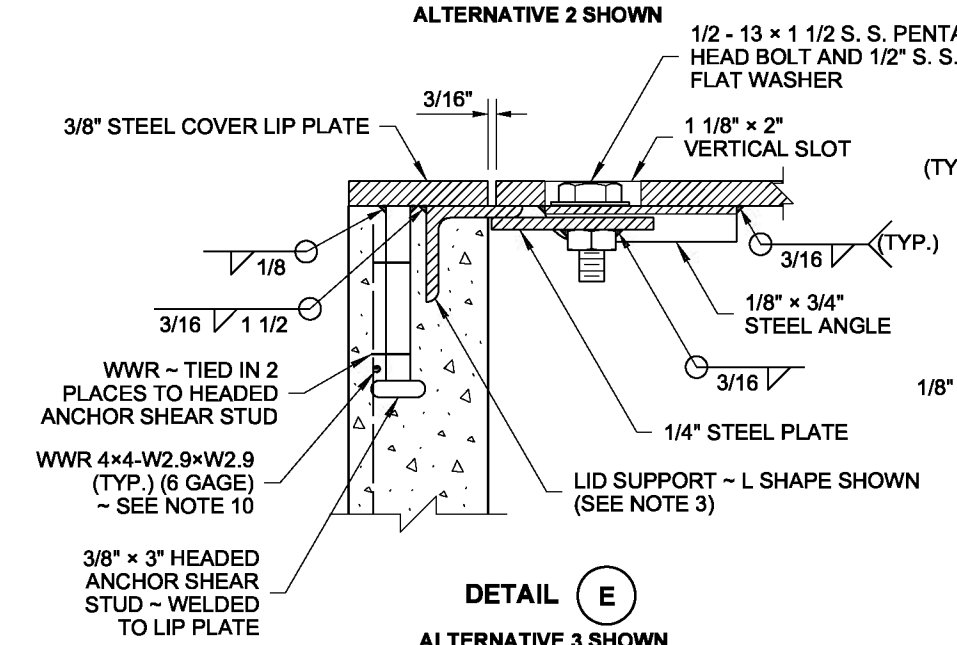

DETAIL E

ALTERNATIVE 3 SHOWN

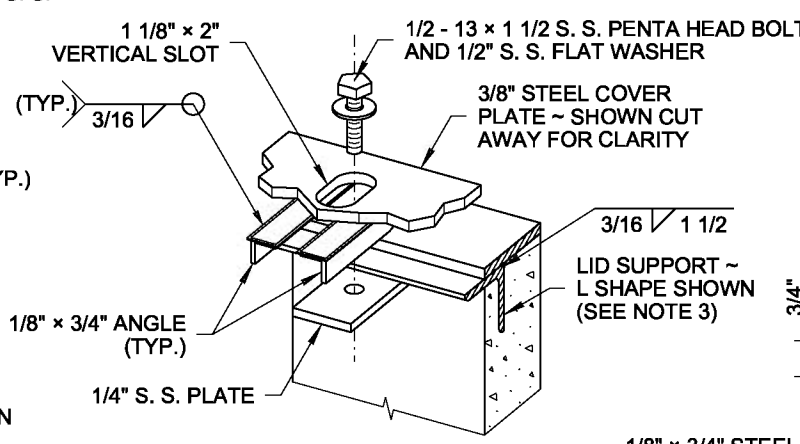

DETAIL F

ALTERNATIVE 3 SHOWN PERSPECTIVE VIEW

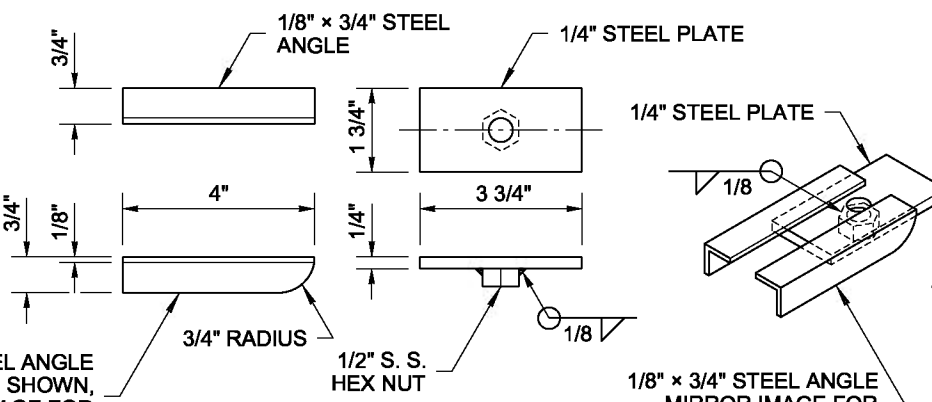

ALTERNATIVE 3 LID BOLT DOWN ATTACHMENT TAB (SEE NOTE 12)

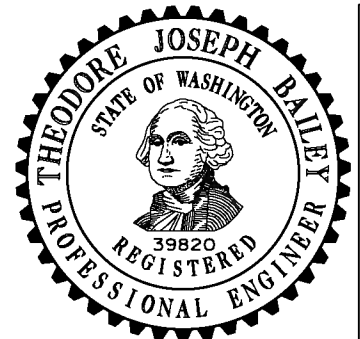

NOTE: THIS PLAN IS NOT A LEGAL ENGINEERING DOCUMENT UNTIL ELECTRONICALLY SIGNED AND SEALED BY THE ENGINEER AND APPROVED FOR PUBLICATION IS FILED AT THE WASHINGTON STATE DEPARTMENT OF TRANSPORTATION. A COPY MAY BE OBTAINED UPON REQUEST.

LOCKING LID STANDARD DUTY JUNCTION BOX TYPES 1 & 2
STANDARD PLAN J-40.10-03

SHEET 2 OF 2 SHEETS

APPROVED FOR PUBLICATION

Pasco Bakotich III 5/20/13
 STATE DESIGN ENGINEER DATE

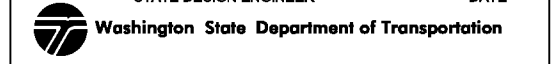

DRAWN BY: ELENA BRUNSTEIN

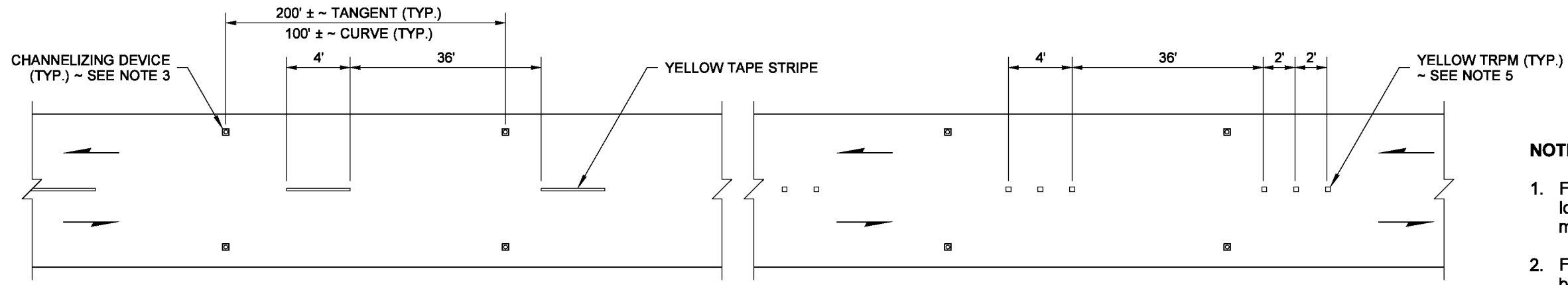

HOT MIXED ASPHALT PAVEMENT

BITUMINOUS SURFACE TREATMENT

TWO-LANE ROADWAY

NOTES

1. For long term projects conflicting pavement markings that are no longer applicable shall be removed or obliterated. Temporary markings shall be used as necessary.
2. For Hot Mixed Asphalt Pavement, a temporary striping tape shall be installed in conjunction with "DO NOT PASS" and "PASS WITH CARE" sign locations.
3. Temporary roadside delineation with Channelization Devices is optional. The appropriate taper length shall be L/2. See Standard Plan K-24.20 for minimum taper length (L).
4. For long term projects a channelization/pavement marking plan should be implemented.
5. Temporary Raised Pavement Marker (TRPM) may be used on a pattern spacing 5' O.C. to simulate a solid line.

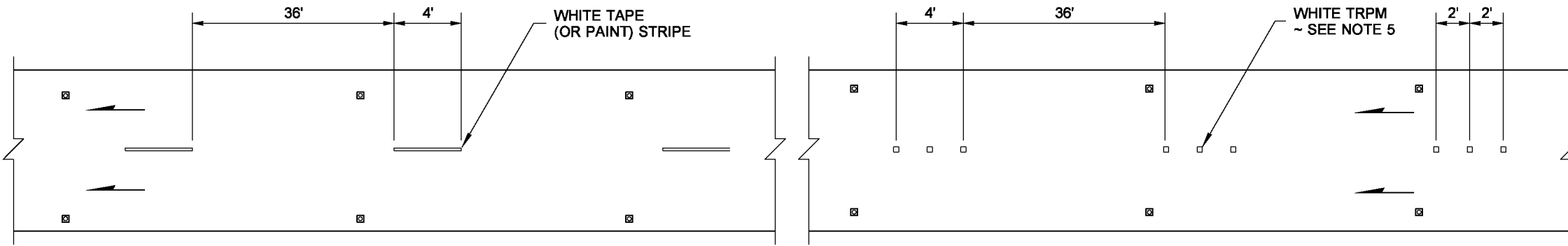

HOT MIXED ASPHALT PAVEMENT

BITUMINOUS SURFACE TREATMENT

ONE-WAY TWO-LANE ROADWAY

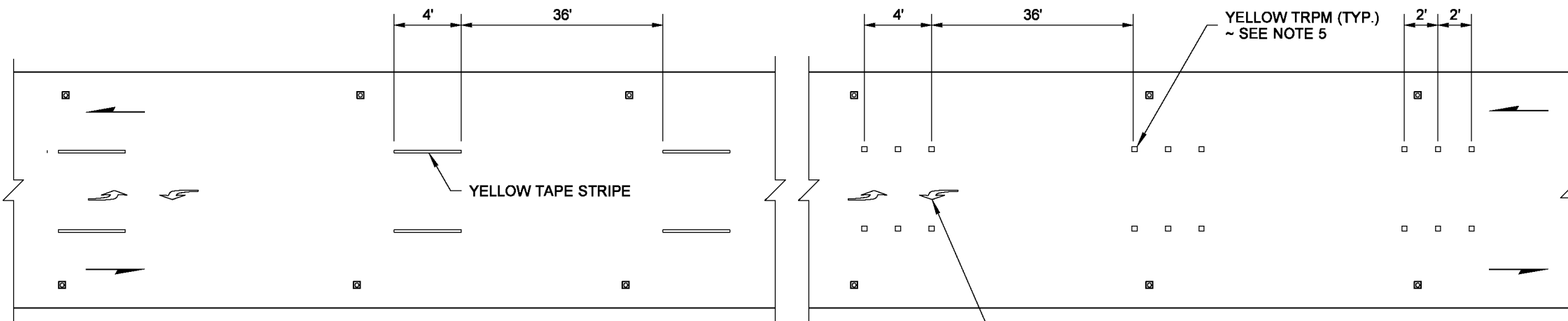

HOT MIXED ASPHALT PAVEMENT

BITUMINOUS SURFACE TREATMENT

TWO-WAY TWO-LANE LEFT TURN ROADWAY



EXPIRES AUGUST 9, 2007

NOTE: THIS PLAN IS NOT A LEGAL ENGINEERING DOCUMENT UNTIL ELECTRONICALLY SIGNED BY THE ENGINEER AND APPROVED FOR PUBLICATION IS FILED AT THE WASHINGTON STATE DEPARTMENT OF TRANSPORTATION. A COPY MAY BE OBTAINED UPON REQUEST.

TEMPORARY CHANNELIZATION
STANDARD PLAN K-70.20-00

SHEET 1 OF 1 SHEET

APPROVED FOR PUBLICATION

Ken L. Smith
STATE DESIGN ENGINEER

02-15-07
DATE



GENERAL NOTES

200 AMP TYPE 120/240 1 ϕ SERVICE CABINET

- SEE STD. SPECIFICATION 9-29.24, SERVICE CABINETS.
- HINGES SHALL HAVE STAINLESS STEEL OR BRASS PINS.
- CABINETS SHALL BE RATED NEMA 3R AND SHALL INCLUDE TWO RAIN TIGHT VENTS.
- METERING EQUIPMENT DOOR SHALL BE PAD LOCKABLE. EACH DOOR SHALL BE GASKETED. INSTALL BEST CX CONSTRUCTION CORE ON BOTTOM DOOR. SEE DOOR HINGE DETAIL, STANDARD PLAN J-3b. CONCEALED HEAVY DUTY STAINLESS STEEL LIFT OFF HINGES ARE ALLOWED AS AN ALTERNATIVE TO DOOR HINGE DETAIL SHOWN ON STANDARD PLAN J-3b. UPPER DOOR SHALL HAVE 2 HINGES AND LOWER DOOR SHALL HAVE 3 HINGES. THE LOWER DOOR SHALL HAVE A TWO POSITION DOOR STOP ASSEMBLY.
- THE FOLLOWING EQUIPMENT WITHIN THE SERVICE ENCLOSURE SHALL HAVE AN APPROPRIATELY ENGRAVED PHENOLIC NAME PLATE ATTACHED WITH SCREWS OR RIVETS: KEY NUMBERS 2, 3, 4, 6, 7, 8, 9, 16 AND 21. KEY NUMBER 4 NAME PLATE SHALL READ: "PHOTOCELL BYPASS TEST ON" AND "PHOTOCELL TEST OFF - AUTOMATIC". SEE SERVICE CABINET DETAIL.
- METERING ARRANGEMENTS VARY WITH DIFFERENT SERVING UTILITIES. THE UTILITY MAY REQUIRE METER BASE MOUNTING IN THE ENCLOSURE, ON THE SIDE OR ON THE BACK OF THE ENCLOSURE. THE UTILITY MAY REQUIRE THE DIMENSION BETWEEN THE DOOR AND THE FRONT OF THE SAFETY SOCKET BOX TO BE LESS THAN THE 11 INCHES SHOWN IN THE LEFT SIDE- SAFETY SOCKET BOX MOUNTING DETAIL. SEE STANDARD PLAN J-3b FOR SAFETY SOCKET BOX DETAIL. THE CONTRACTOR SHALL VERIFY THE SERVING UTILITY'S REQUIREMENTS PRIOR TO FABRICATION OF AND INSTALLING THE SERVICE EQUIPMENT.
- DIMENSIONS SHOWN ARE MINIMUM AND SHALL BE ADJUSTED TO ACCOMMODATE THE VARIOUS SIZES OF EQUIPMENT INSTALLED.
- ALL BUSSWORK SHALL BE HIGH GRADE COPPER AND SHALL EQUAL OR EXCEED THE MAIN BREAKER RATING. ALL BREAKERS SHALL BOLT ONTO THE BUSSWORK. JUMPERING OF BREAKERS SHALL NOT BE ALLOWED. BUSSWORK SHALL ACCOMMODATE ALL FUTURE EQUIPMENT AS SHOWN IN THE BREAKER SCHEDULE.
- THE PHOTOCELL UNIT SHALL BE CENTERED IN THE PHOTOCELL ENCLOSURE TO PERMIT 360 DEGREE ROTATION OF THE PHOTOCELL WITHOUT REMOVAL OF THE PHOTOCELL UNIT OR PHOTOCELL ENCLOSURE.
- ALL INTERNAL WIRE RUNS SHALL BE IDENTIFIED WITH "TO - FROM" CODED TAGS LABELED WITH THE CODE LETTERS AND/OR NUMBERS SHOWN ON THE SCHEDULES. APPROVED PVC OR POLYOLEFIN WIRE MARKING SLEEVES SHALL BE USED.
- ALL NUTS, BOLTS AND WASHERS USED FOR MOUNTING THE PHOTOCELL ENCLOSURE SHALL BE STAINLESS STEEL.
- A 1% TOLERANCE IS ALLOWED FOR ALL DIMENSIONS.
- THE PHOTOCELL CIRCUIT SHALL BE INSTALLED IN FLEX CONDUIT WITHIN THE METER COMPARTMENT.
- INSTALL CONDUIT COUPLINGS ON ALL CONDUITS. PLACE COUPLINGS FLUSH WITH TOP OF CONCRETE FOUNDATION.
- SEE PLANS FOR BREAKER SCHEDULE.
- SEAL CABINET TO FOUNDATION WITH A 1/2" BEAD OF SILICONE. APPLY SILICONE TO DRY SURFACE ONLY.
- THE METER BASE PORTION OF THIS SERVICE WAS DESIGNED TO MEET METERING PORTION OF EUSERC DRAWING 309 REQUIREMENTS.

- KEY**
- METER BASE PER SERVING UTILITY REQUIREMENTS. AS A MINIMUM, THE METER BASE SHALL BE SAFETY SOCKET BOX WITH FACTORY INSTALLED TEST BYPASS FACILITY THAT MEETS THE REQUIREMENTS OF EUSERC DRAWING 305.
 - MAIN BREAKER (SEE BREAKER SCHEDULE)
 - PHOTOCELL BREAKER (SPST 15 AMP - 120/240 VOLT)
 - TEST SWITCH (SPDT SNAP ACTION, POSITIVE CLOSE, 15 AMP - 120/277 VOLT "T" RATED)
 - PHOTOELECTRIC CONTROL, STD. SPEC. 9 - 29.11(2)
 - BRANCH BREAKER (SEE BREAKER SCHEDULE)
 - SIGNAL BREAKER (SEE BREAKER SCHEDULE)
 - CONTACTOR (SEE BREAKER SCHEDULE)
 - RECEPTACLE BREAKER (SPST 20 AMP - 120/240 VOLT)
 - RECEPTACLE, GROUNDED (GFCI 20 AMP - 125 VOLT)
 - NEUTRAL BUSS, 14 LUG COPPER
 - PHOTOCELL ENCLOSURE - ENCLOSURE TO BE FABRICATED FROM 5/8" EXPANDED STEEL MESH WITH WELDED SEAMS AND MOUNTING FLANGES. HOT DIP GALVANIZED AFTER FABRICATION. TYPE 5052 - H32 ALUMINUM WITH 5/8" x 5/8" OPENINGS EQUIVALENT TO 5/8" EXPANDED STEEL MESH MAY BE USED AS ALTERNATIVE MATERIAL. SEE PHOTOCELL ENCLOSURE MOUNTING DETAILS, STANDARD PLAN J-3b.
 - HINGED FRONT FACING DOOR WITH 4" x 4" MIN. POLISHED WIRE GLASS WINDOW.
 - HINGED DEAD FRONT WITH 1/4 TURN FASTENERS OR SLIDE LATCH.
 - CABINET MAIN BONDING JUMPER. BUSS SHALL BE 4 LUG TINNED COPPER. SEE CABINET MAIN BONDING JUMPER DETAIL, STANDARD PLAN J-3b.
 - SPARE BRANCH BREAKER (DPST 20AMP- 120/240 VOLT)
 - METAL WIRING DIAGRAM HOLDER
 - REMOVABLE EQUIPMENT MOUNTING PAN
 - 6" x 6" MIN. UNDERGROUND FEED - SERVICE WIREWAY (LEFT REAR CORNER)
 - SCREENED VENTS, 2 REQUIRED, 1 EACH SIDE, LOUVERED PLATES.
 - HEATER BREAKER (SPST 15 AMP - 120/240 VOLT)
 - THERMOSTAT, 40°F CLOSURE - 3 DIFFERENTIAL
 - STRIP HEATER (100 WATT NOMINAL), WITH TERMINAL STRIP COVER.
 - 24 CIRCUIT PANEL BOARD - MINIMUM SIZE WITH SEPARATE MAIN BREAKER.
 - LABEL CABINET WITH BUSSWORK RATING.

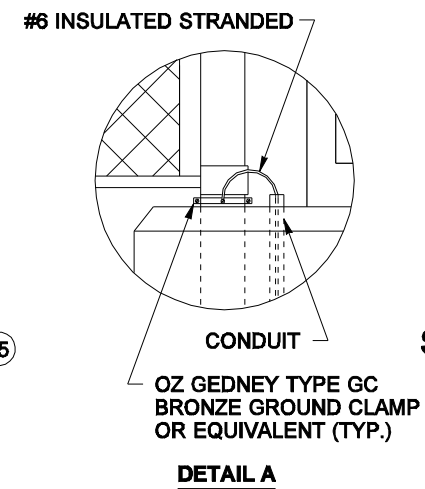
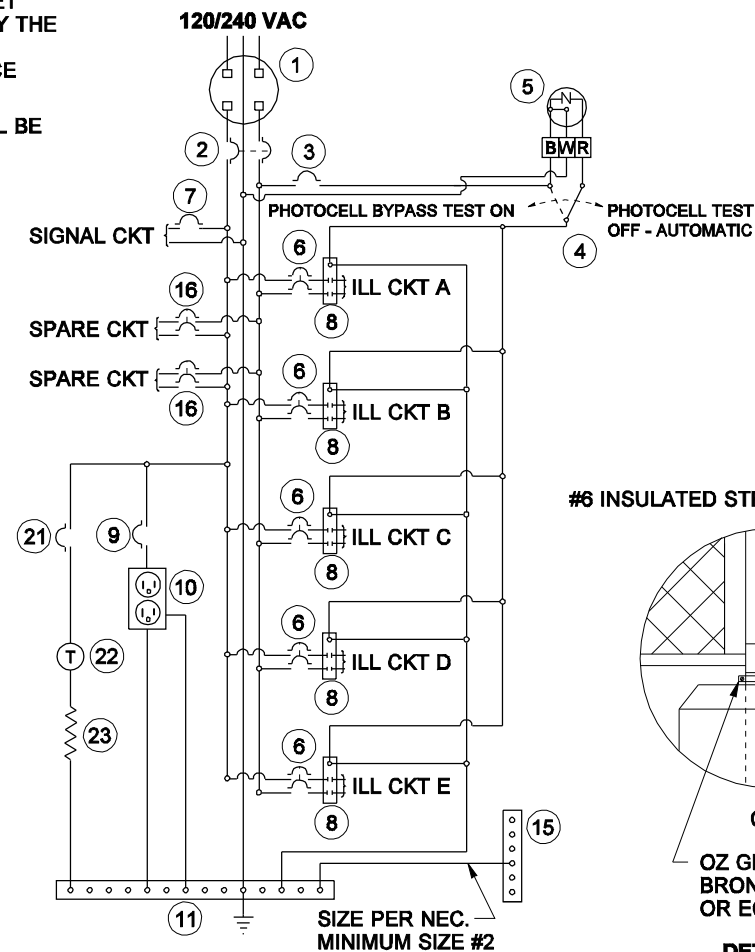
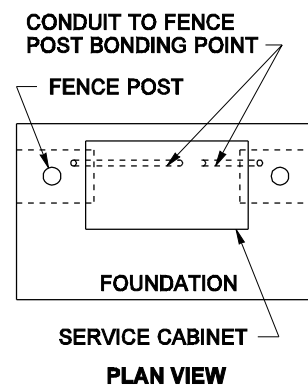
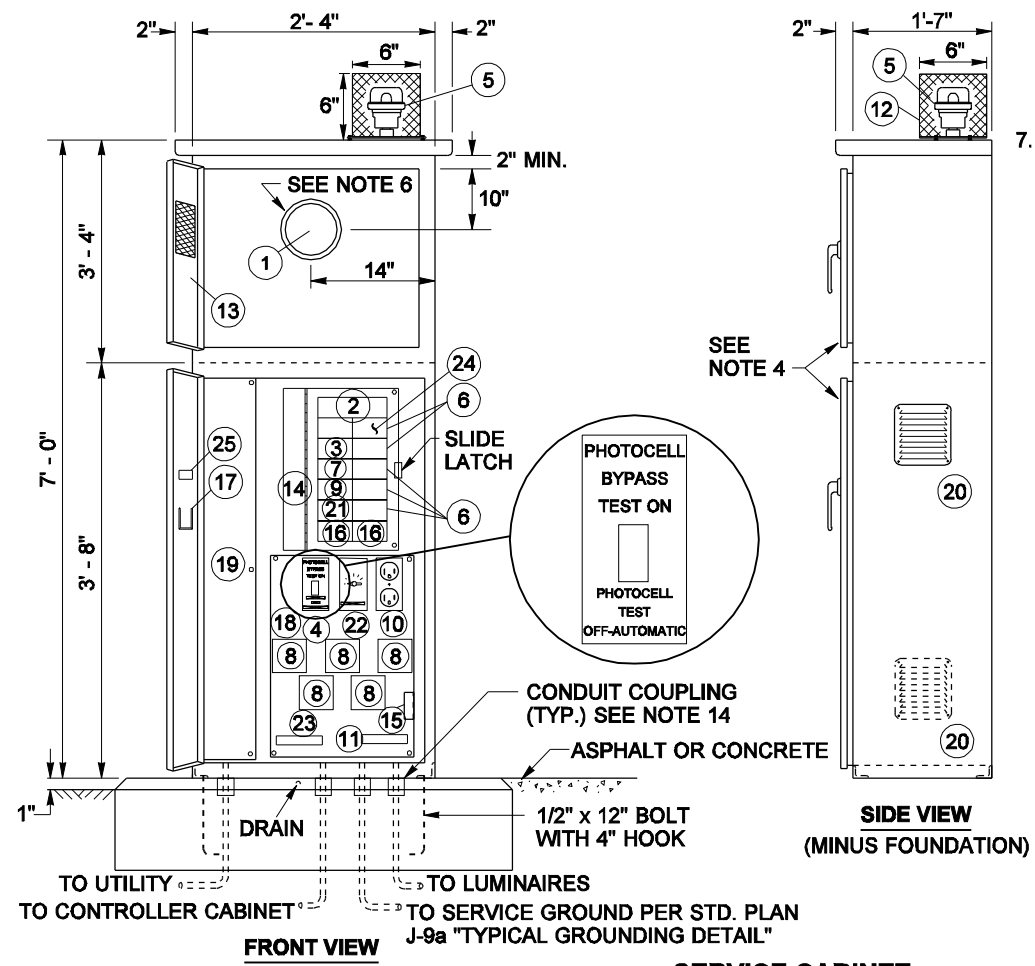
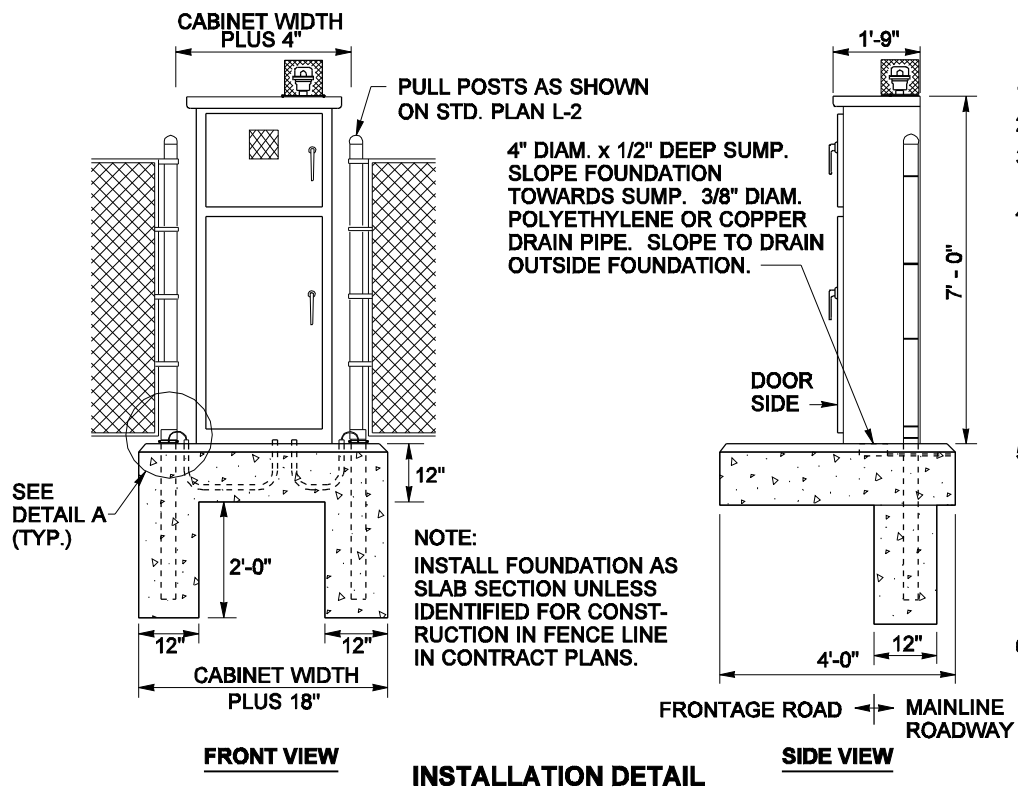

EXPIRES MAY 5, 2003

SERVICE CABINET TYPE D (0 - 200 AMP TYPE 120/240 SINGLE PHASE) STANDARD PLAN J-3c

SHEET 1 OF 1 SHEET

APPROVED FOR PUBLICATION

Harold J. Peterfeso 06-24-02

STATE DESIGN ENGINEER DATE



NOTE: THIS PLAN IS NOT A LEGAL ENGINEERING DOCUMENT BUT AN ELECTRONIC INSTRUMENT. THE ORIGINAL, SIGNED BY THE ENGINEER AND APPROVED FOR PUBLICATION, IS KEPT ON FILE AT THE WASHINGTON STATE DEPARTMENT OF TRANSPORTATION. A COPY MAY BE OBTAINED UPON REQUEST.

DRAWN BY: LISA CYFORD

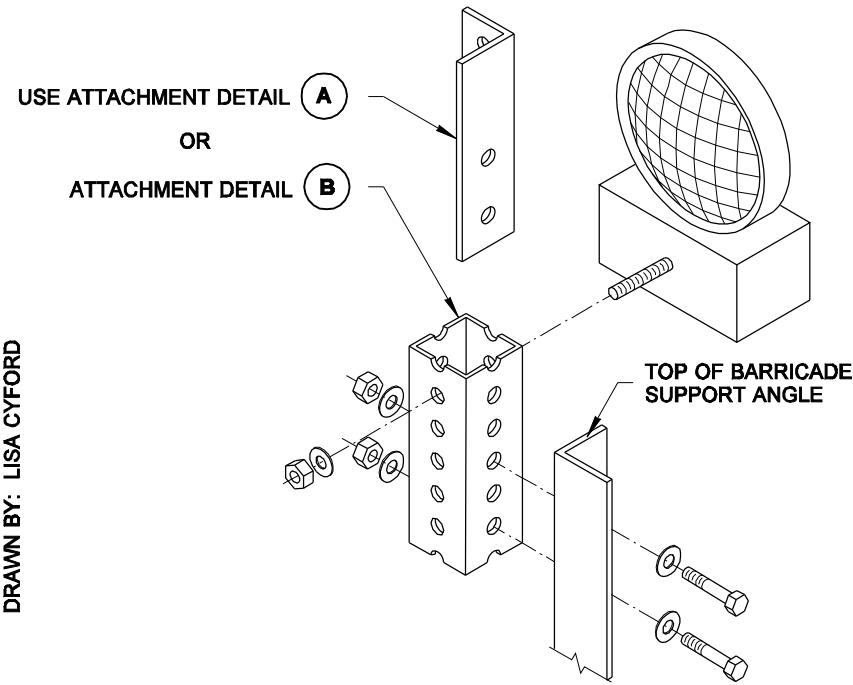

WARNING LIGHT ATTACHMENT DETAIL

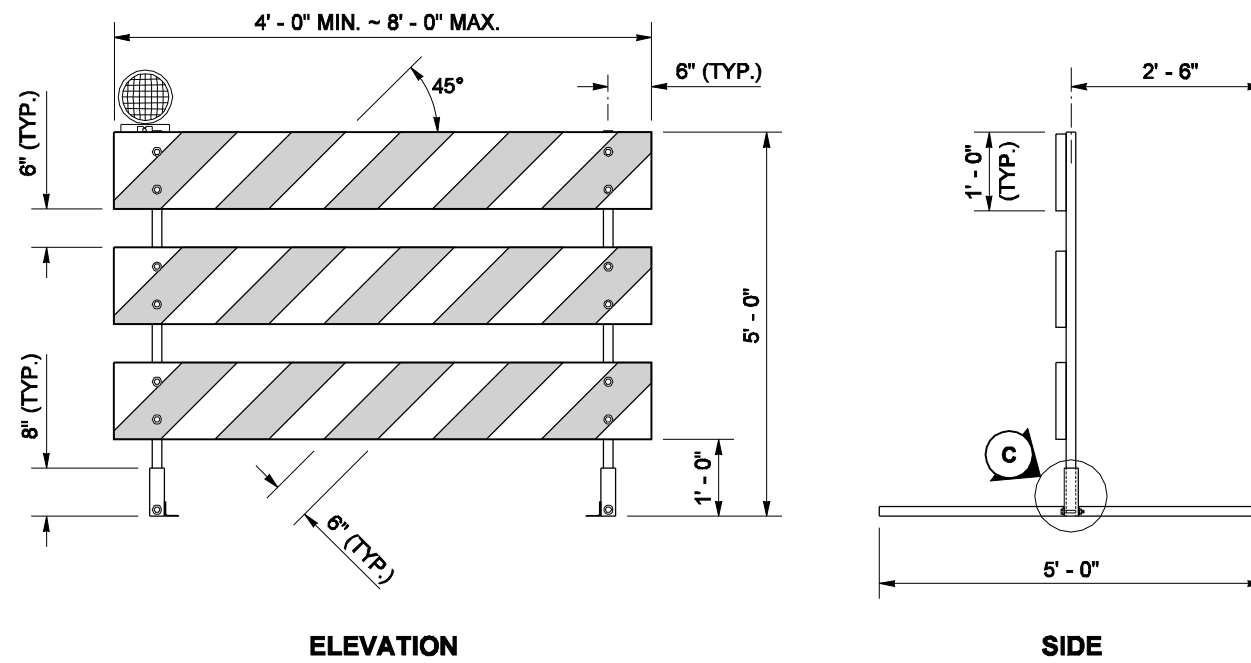

TYPE 3 BARRICADE

NOTES

1. All fasteners may be zinc plated, galvanized or stainless steel. All steel angle and tubular steel shall be hot-rolled, high carbon steel, painted or galvanized.
2. Install one lightweight Type A Low-Intensity flashing warning light on the traffic side of the barricade. Install two Type A Low-Intensity flashing warning lights per barricade when the barricades are used to close a roadway. Attach the light to the barricade according to the light manufacturer's recommendations or use the details shown on this plan.
3. Stripes on barricade rails shall be alternating orange and white retroreflective stripes (sloping downward at an angle of 45 degrees in the direction traffic is to pass).
4. The Type 3 barricade design shown on this plan meets the crash test requirements of NCHRP 350. Alternative designs may be approved if they conform to the NCHRP 350 crash test criteria and the MUTCD.
5. When a sign is mounted on the barricade, it shall be securely bolted to at least two plywood panels. The top of the sign shall not be higher than the top panel of the barricade.
6. When sandbags are used in freezing weather, Urea fertilizer shall be mixed with the sand in a quantity to prevent the sand from freezing.

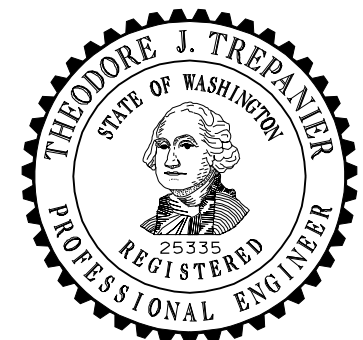
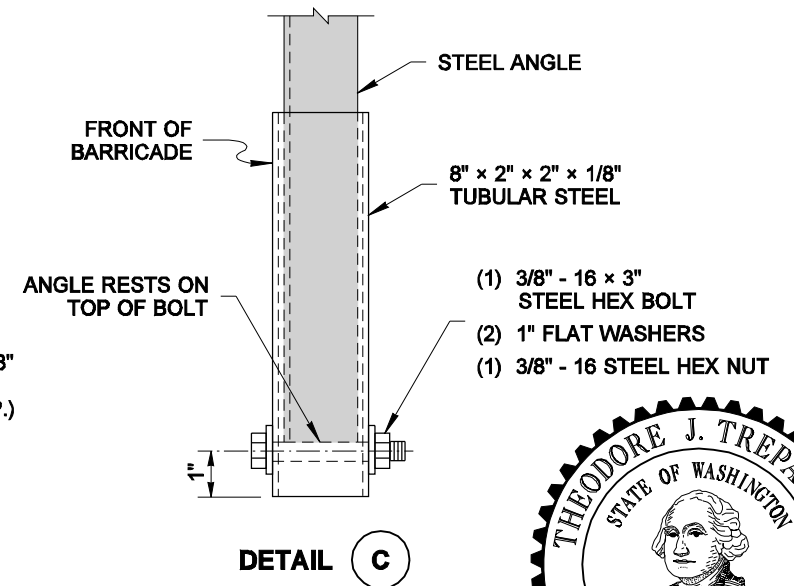
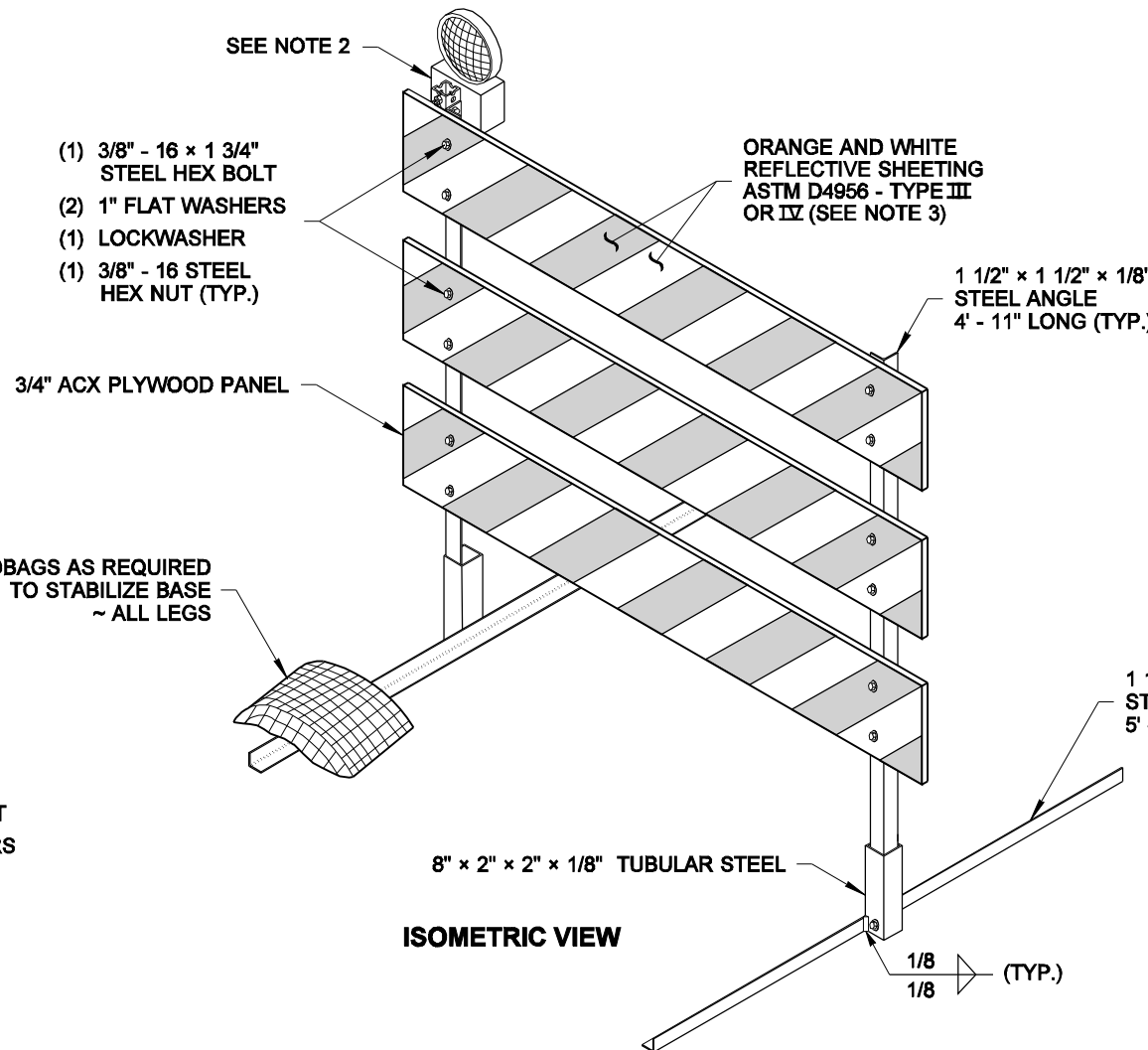
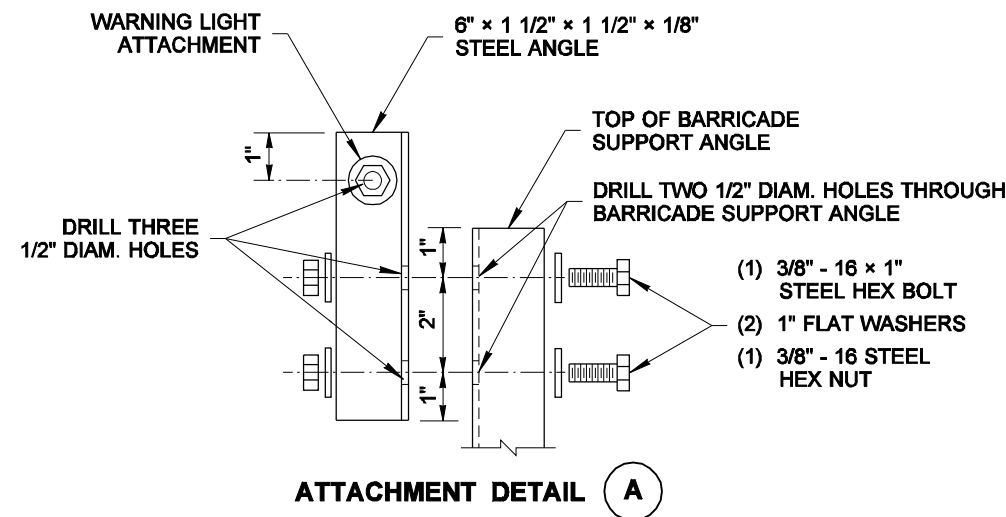

NOTE: THIS PLAN IS NOT A LEGAL ENGINEERING DOCUMENT UNTIL AN ELECTRONIC OR ORIGINAL COPY IS FILED AT THE WASHINGTON STATE DEPARTMENT OF TRANSPORTATION. A COPY MAY BE OBTAINED UPON REQUEST.

TYPE 3 BARRICADE
STANDARD PLAN K-80.20-00
SHEET 1 OF 2 SHEETS

APPROVED FOR PUBLICATION
Kevin J. Dayton 12-20-06
STATE DESIGN ENGINEER DATE
Washington State Department of Transportation

DRAWN BY: LISA CYFORD

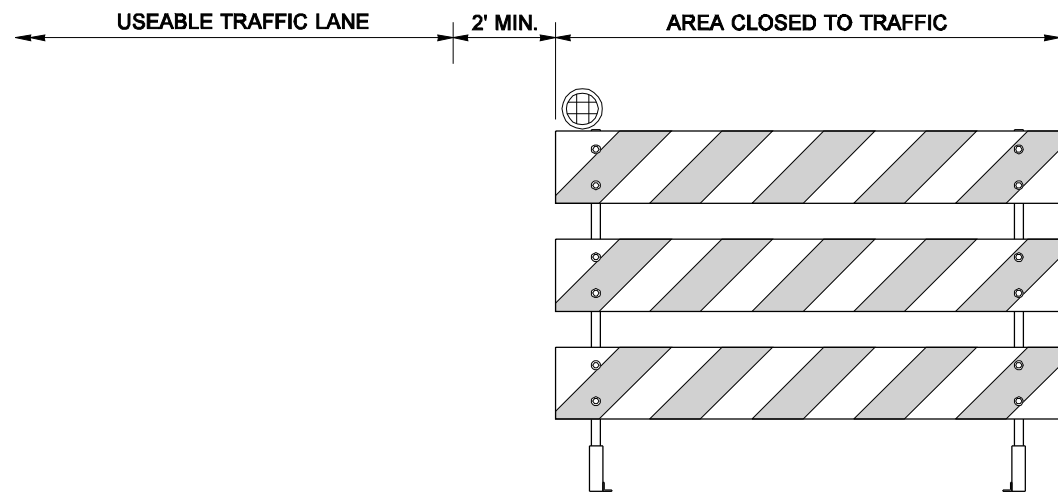

TYPE 3L BARRICADE

STRIPES ON THE BARRICADES SHALL SLOPE
DOWNWARD IN THE DIRECTION TRAFFIC IS TO PASS

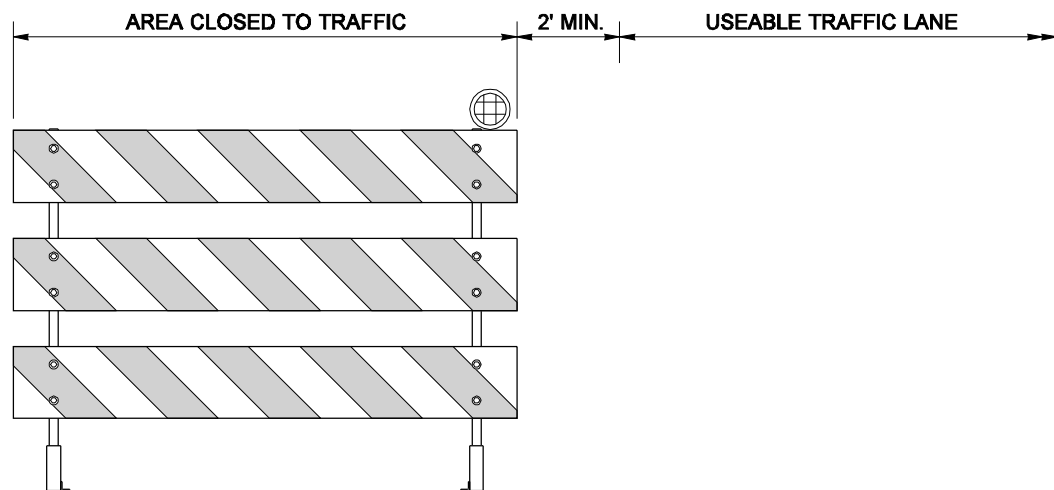

TYPE 3R BARRICADE

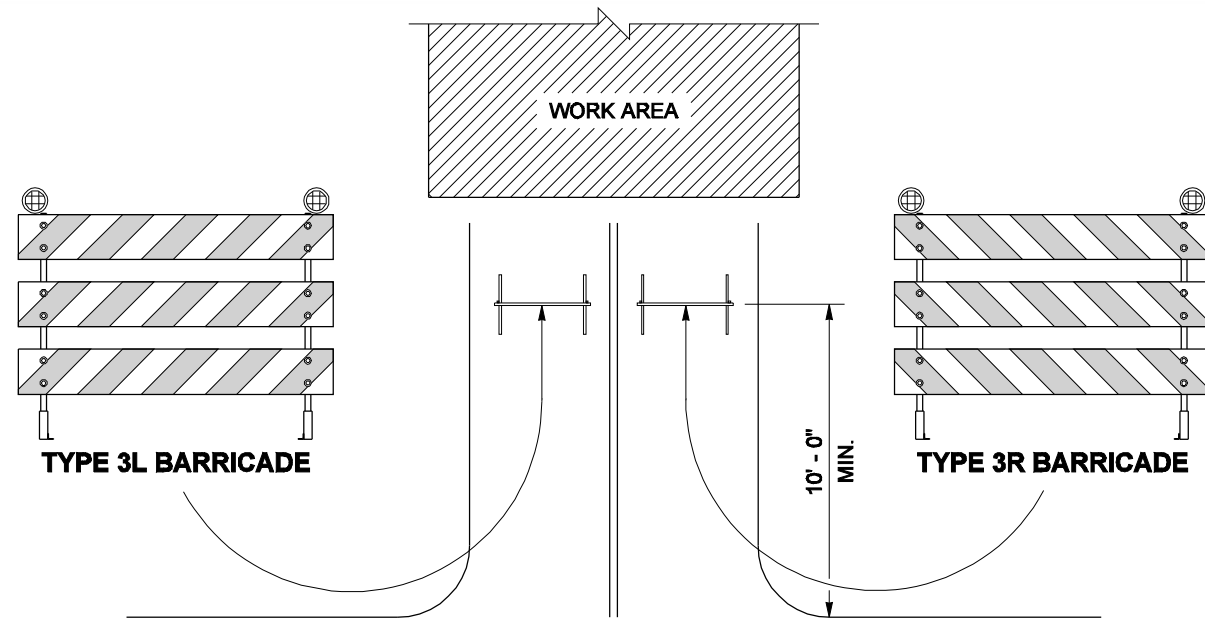

ROAD CLOSURE AT INTERSECTION

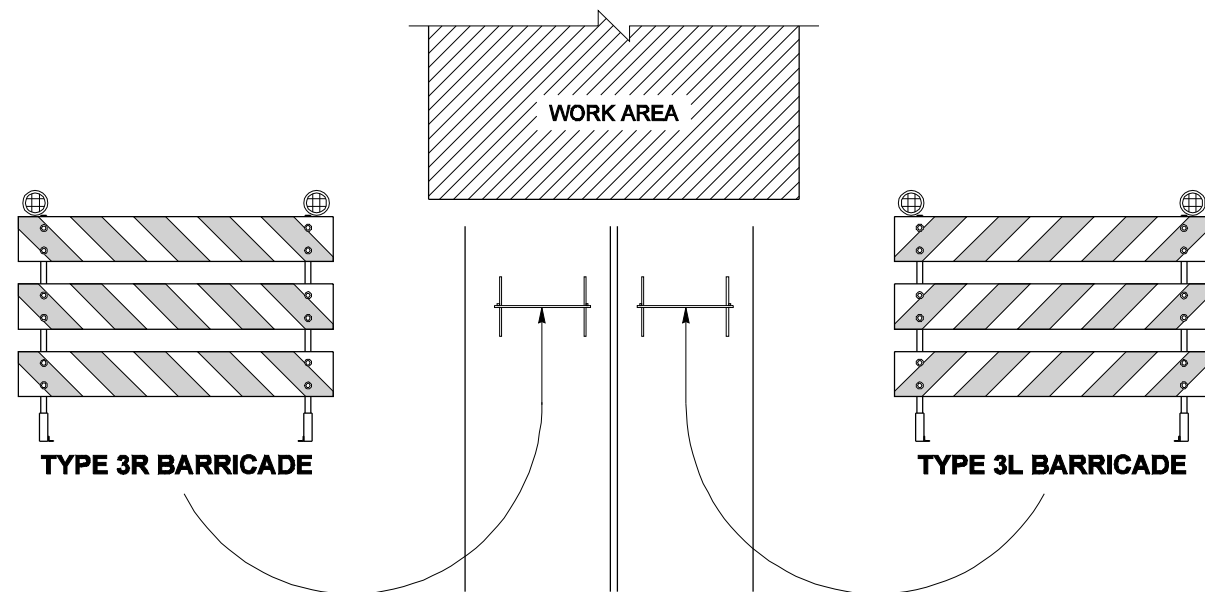

ROAD CLOSURE AT OTHER LOCATIONS

BARRICADE PLACEMENT

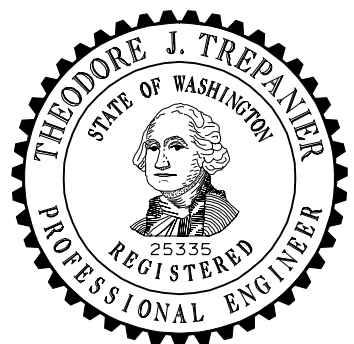

EXPIRES AUGUST 9, 2007

NOTE: THIS PLAN IS NOT A LEGAL ENGINEERING DOCUMENT
UNTIL AN ELECTRONIC DIGITAL SIGNATURE IS APPLIED TO THE ORIGINAL SIGNED BY
THE ENGINEER AND APPROVED FOR PUBLICATION IS KEPT ON
FILE AT THE WASHINGTON STATE DEPARTMENT OF TRANSPORTATION. A COPY MAY BE OBTAINED UPON REQUEST.

TYPE 3 BARRICADE

STANDARD PLAN K-80.20-00

SHEET 2 OF 2 SHEETS

APPROVED FOR PUBLICATION

Kevin J. Dayton 12-20-06

STATE DESIGN ENGINEER DATE



Washington State Department of Transportation

DRAWN BY: MARK SUJKA

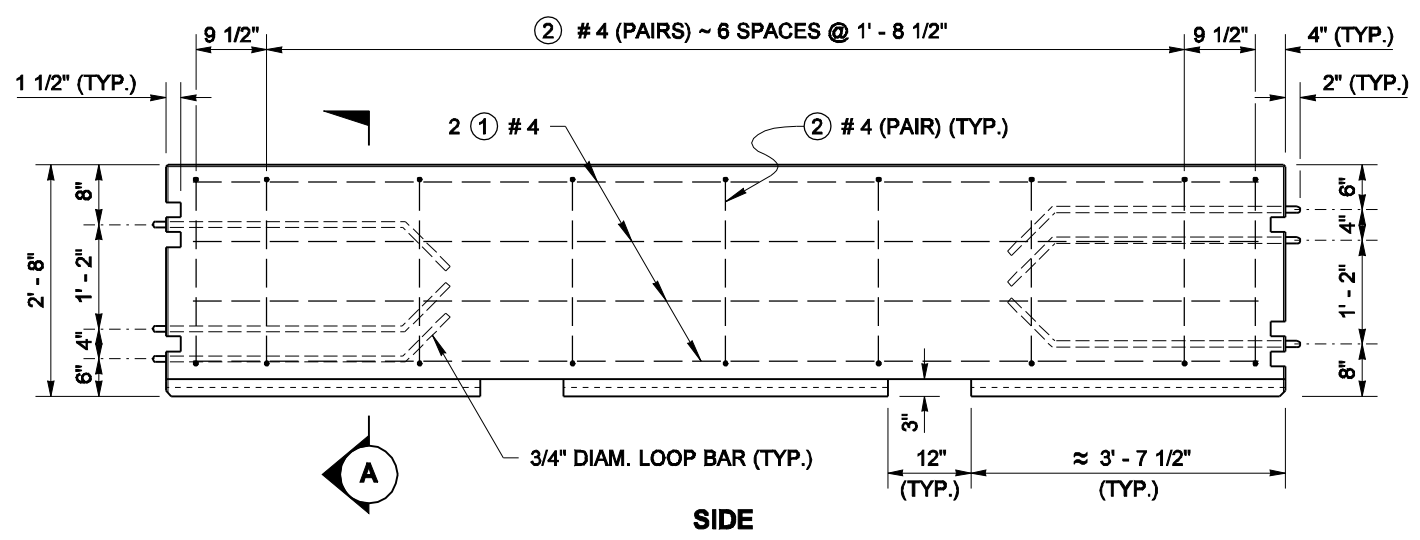
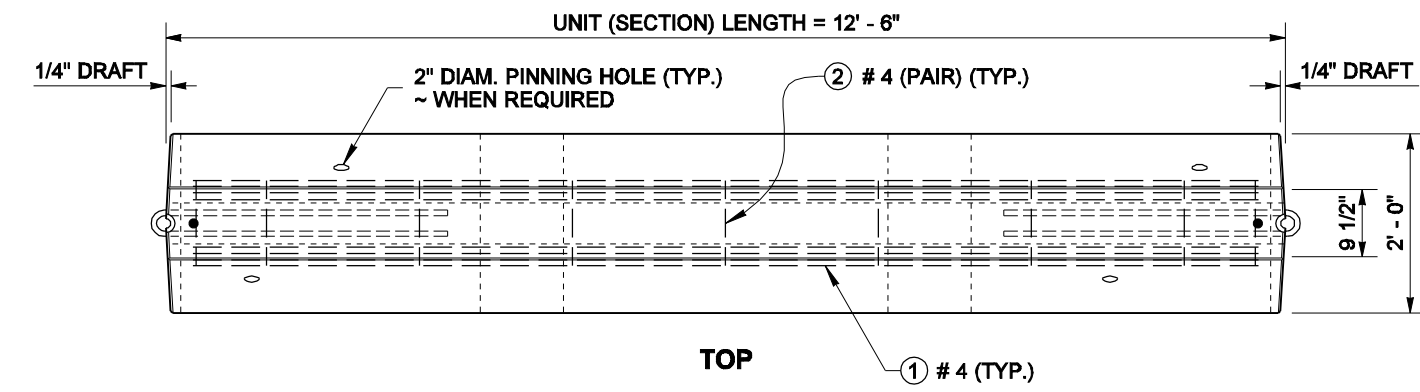
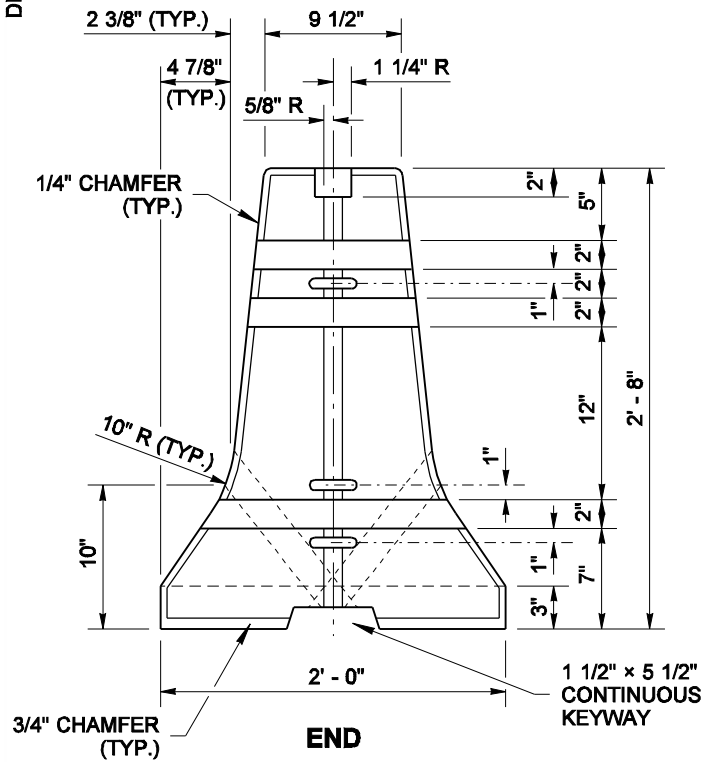

NOTES

1. The reinforcing steel details for the NARROW BASE barrier are the same as those shown for the 2' wide barrier except that the bars along the vertical face run vertically with a 1 1/2" clearance.
2. The vertical dimensions for the slots and loop bar locations on the NARROW BASE barrier are the same as those shown on the END views of the 2' wide barrier.

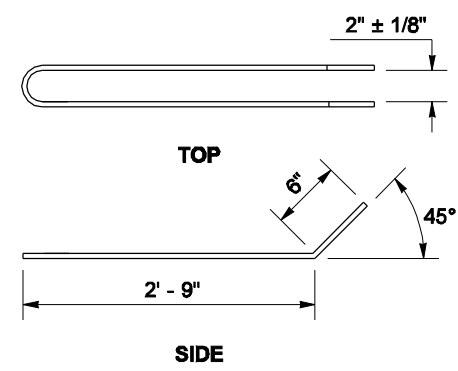
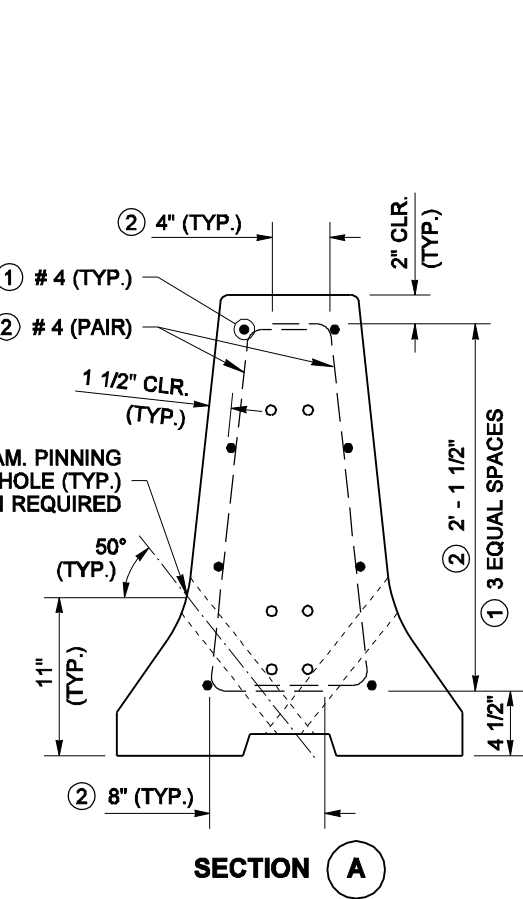
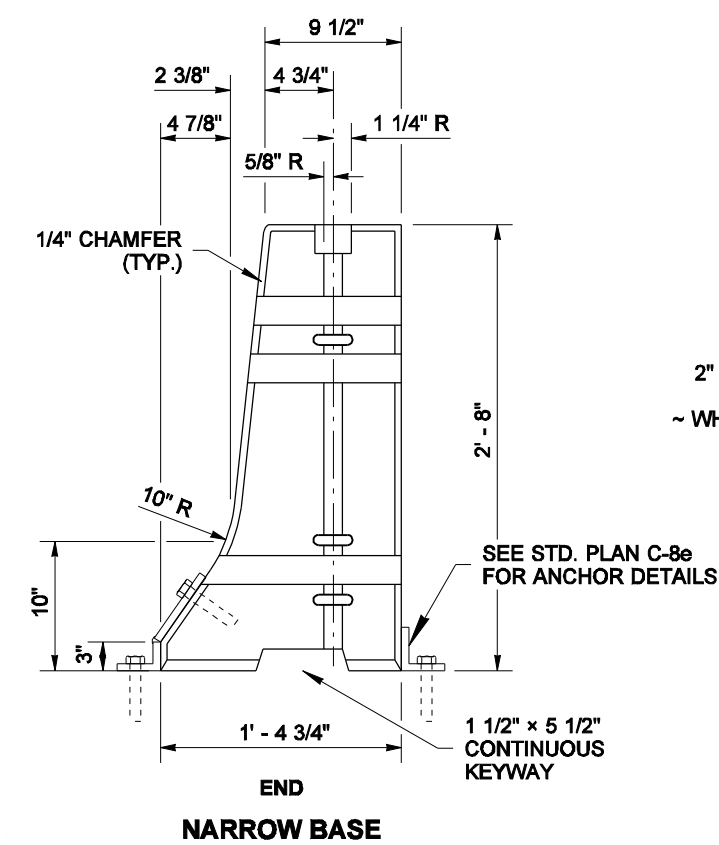
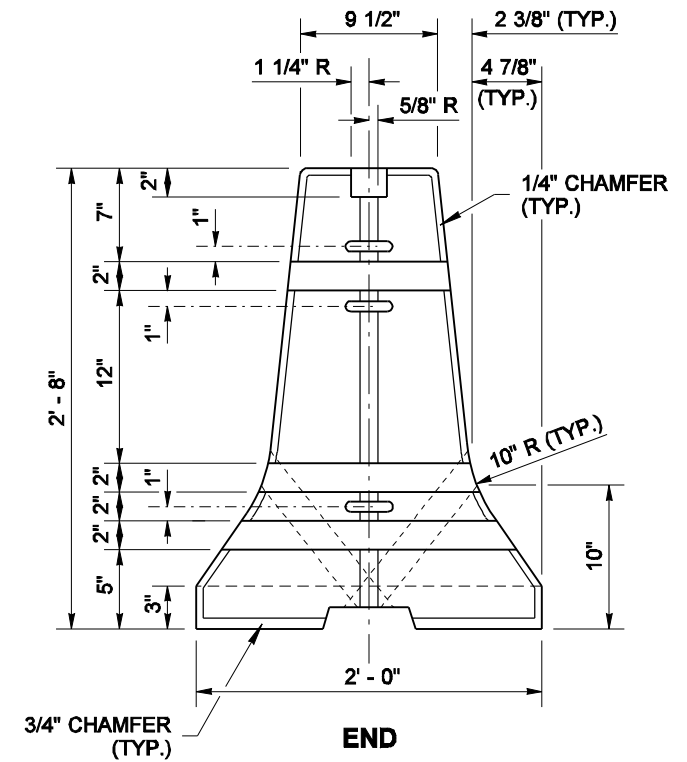

ALTERNATIVE LOOP BAR
 3/4" DIAM. (ASTM A 36)
 HOT DIP GALVANIZE AFTER FABRICATION (ASTM A 123)

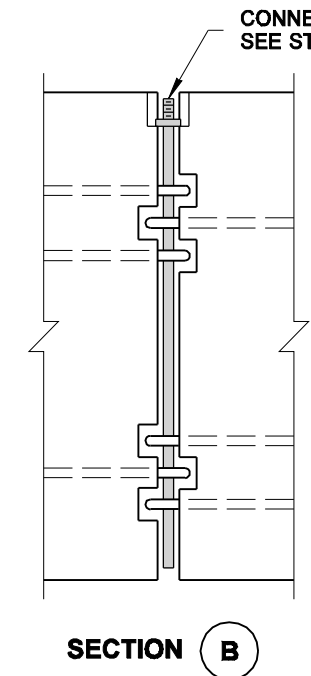
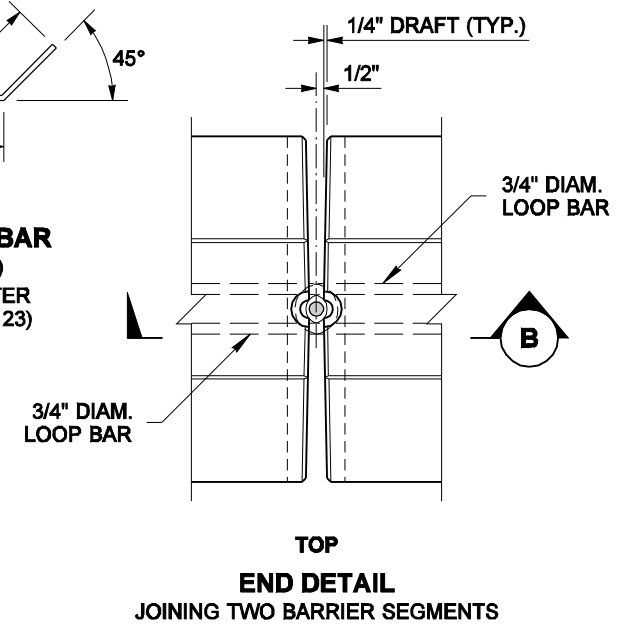

EXPIRES JULY 24, 2008

ALTERNATIVE TEMPORARY CONC. BARRIER (F-SHAPE) STANDARD PLAN K-80.30-00

SHEET 1 OF 1 SHEET

APPROVED FOR PUBLICATION

Ken L. Smith 02-21-07
 STATE DESIGN ENGINEER DATE



NOTE: THIS PLAN IS NOT A LEGAL ENGINEERING DOCUMENT BUT AN ELECTRONIC DUPLICATE. THE ORIGINAL, SIGNED BY THE ENGINEER AND APPROVED FOR PUBLICATION, IS KEPT ON FILE AT THE WASHINGTON STATE DEPARTMENT OF TRANSPORTATION. A COPY MAY BE OBTAINED UPON REQUEST.

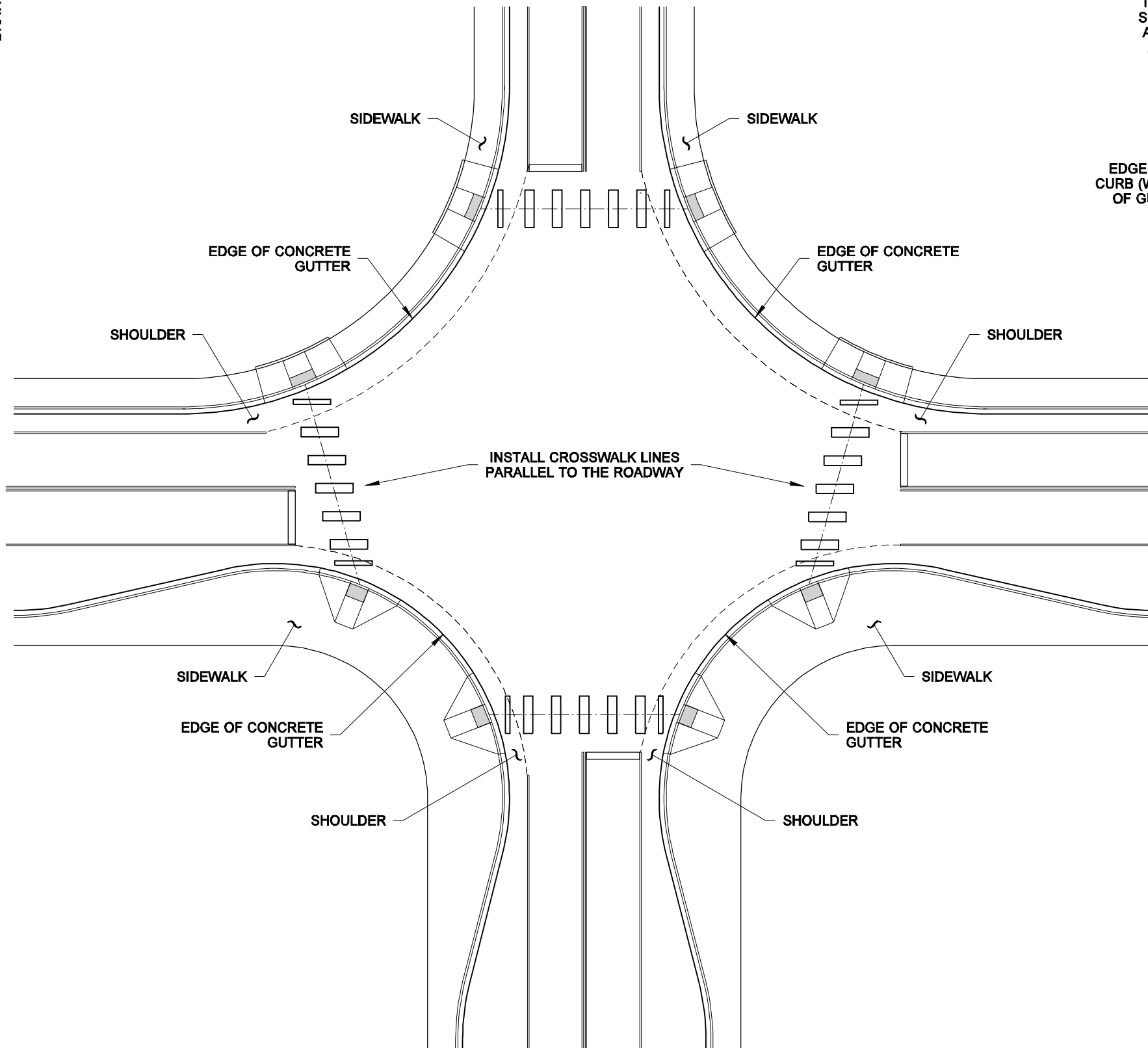

TYPICAL APPLICATIONS

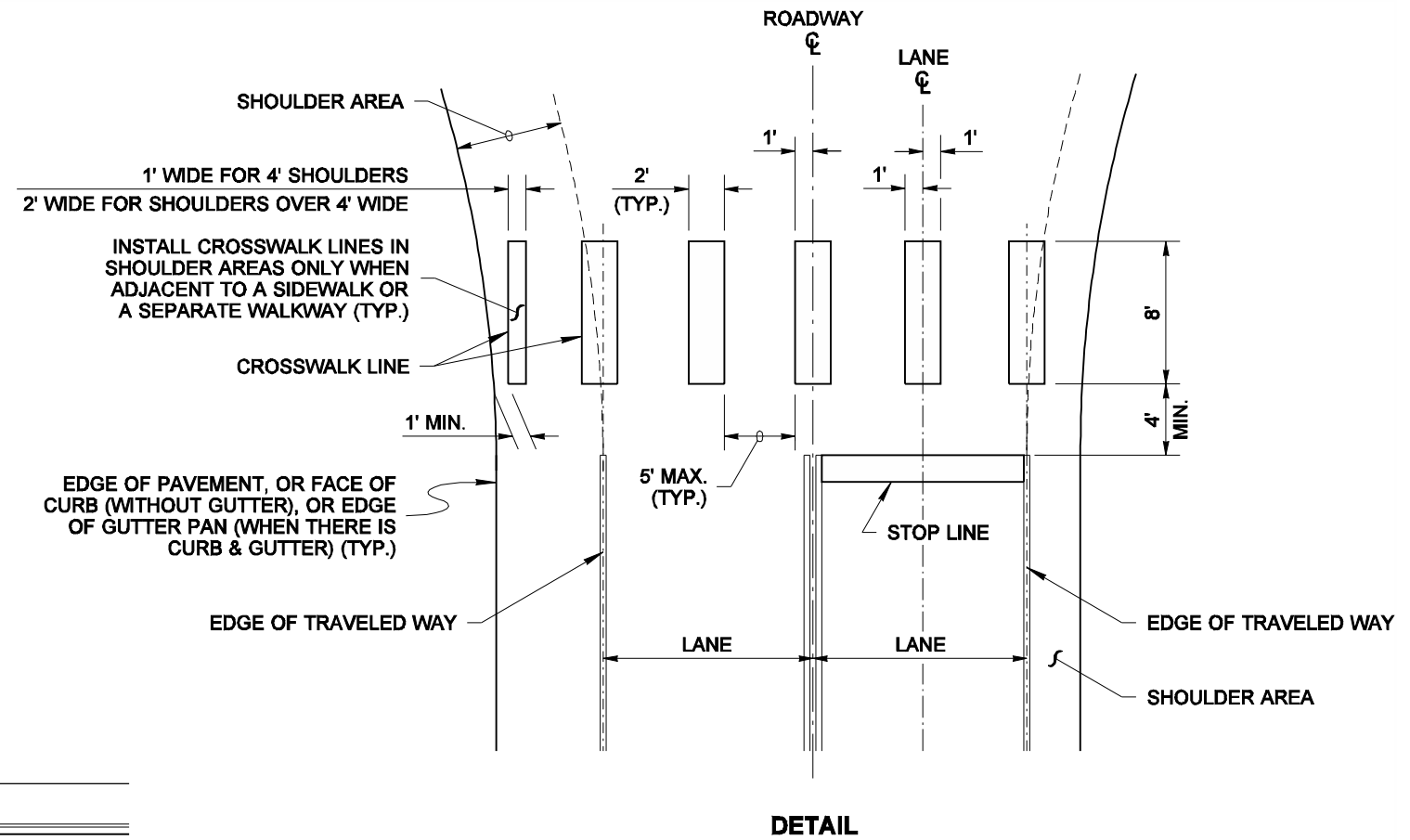

NOTES

1. See the Contract Plans for locations of crosswalk centerlines.
2. To the maximum extent possible, curb ramp centerline should be perpendicular to the crosswalk centerline.
3. To the maximum extent possible, crosswalks should be perpendicular to the centerline of the traveled way.

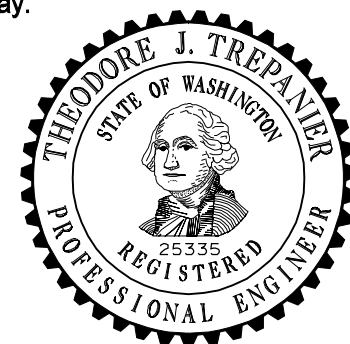

EXPIRES AUGUST 9, 2007

NOTE: THIS PLAN IS NOT A LEGAL ENGINEERING DOCUMENT BUT AN ELECTRONIC DUPLICATE. THE ORIGINAL, SIGNED BY THE ENGINEER AND APPROVED FOR PUBLICATION, IS KEPT ON FILE AT THE WASHINGTON STATE DEPARTMENT OF TRANSPORTATION. A COPY MAY BE OBTAINED UPON REQUEST.

CROSSWALK LAYOUT

STANDARD PLAN M-15.10-01

SHEET 1 OF 1 SHEET

APPROVED FOR PUBLICATION

Ken L. Smith

STATE DESIGN ENGINEER

02-06-07

DATE



Washington State Department of Transportation

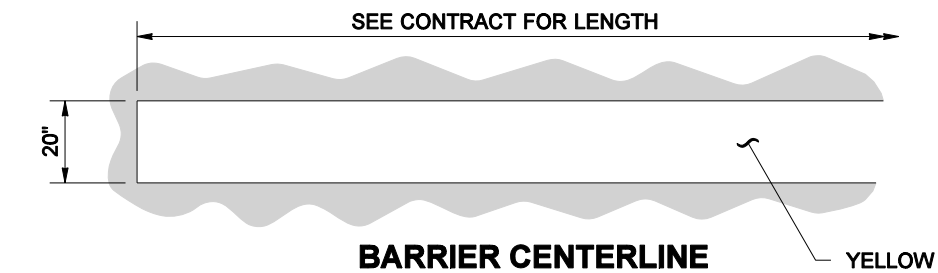
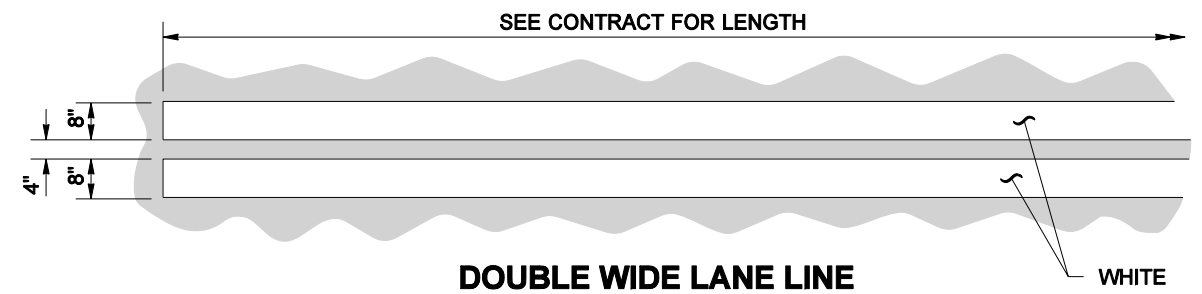
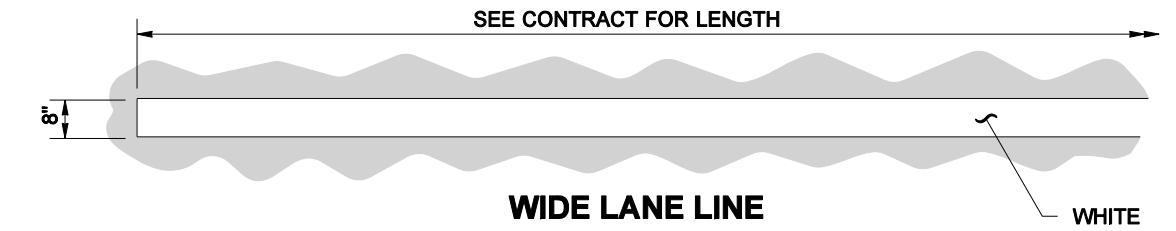
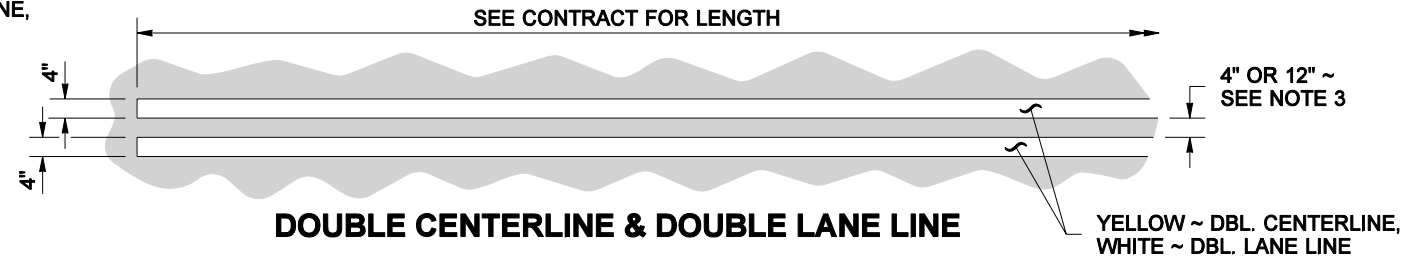
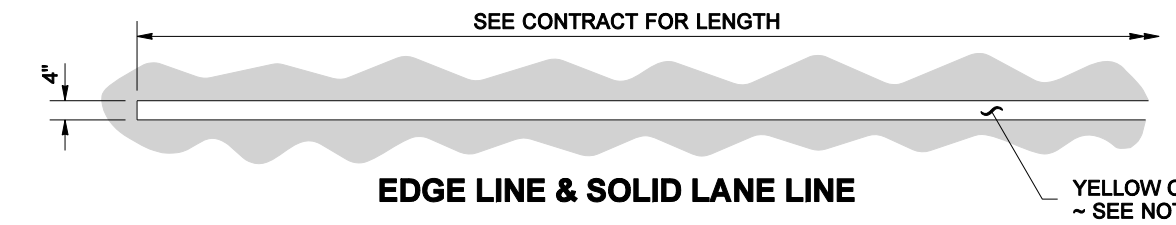
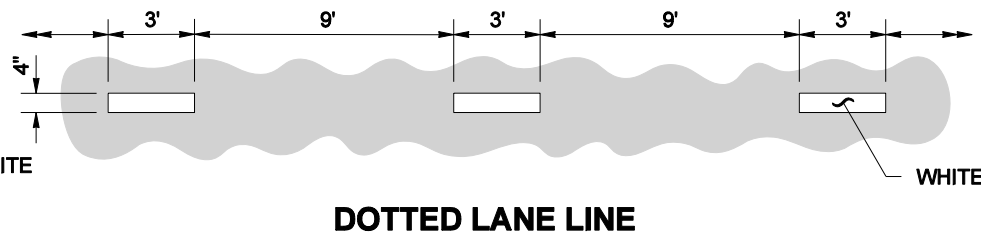
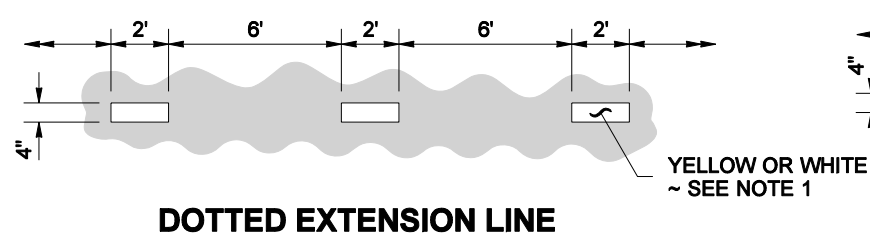
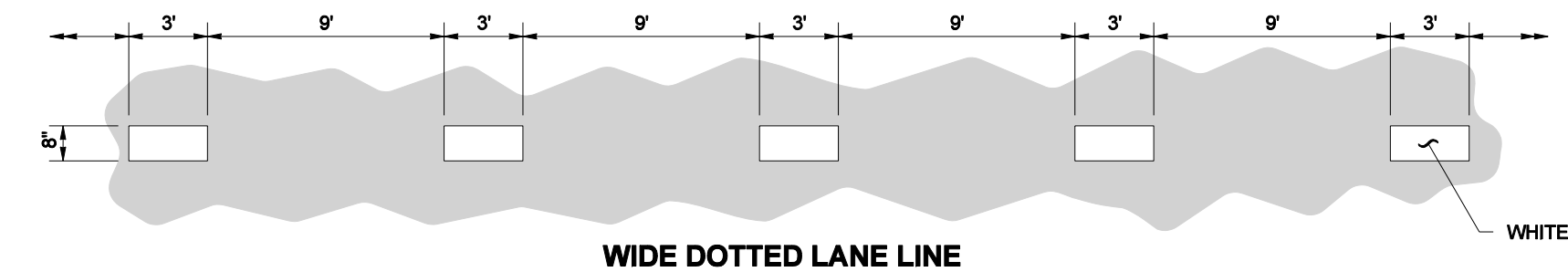
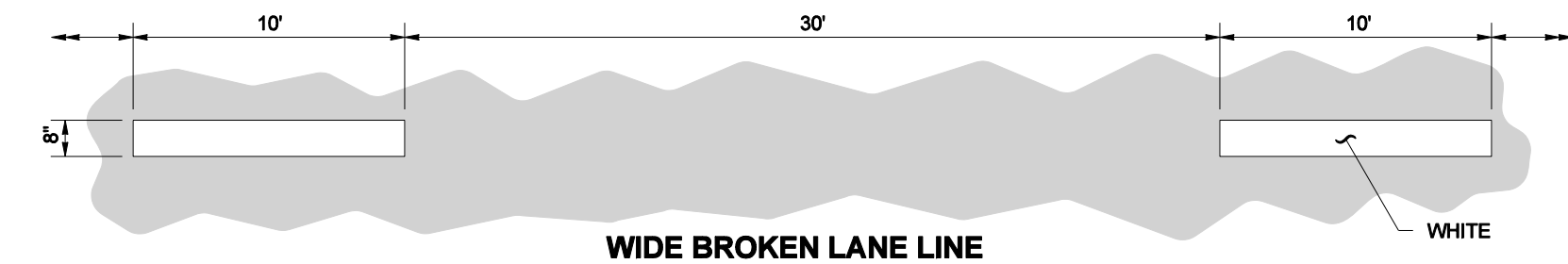
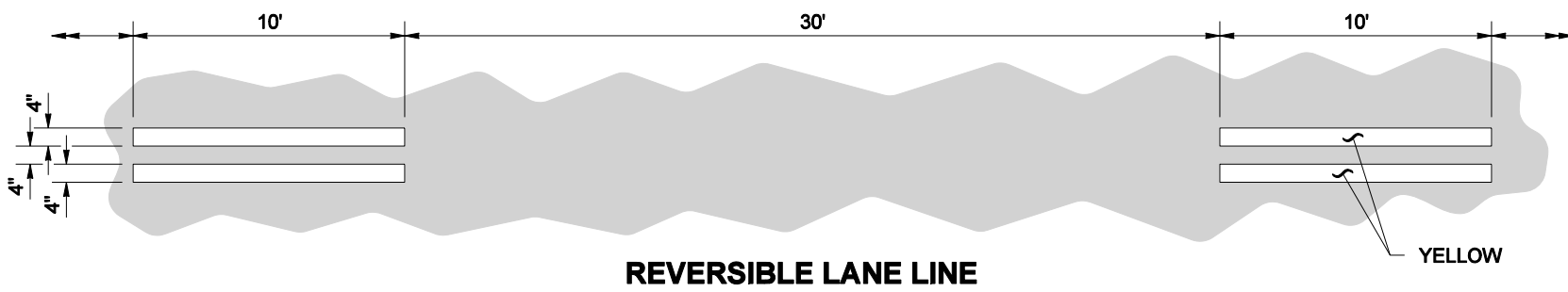
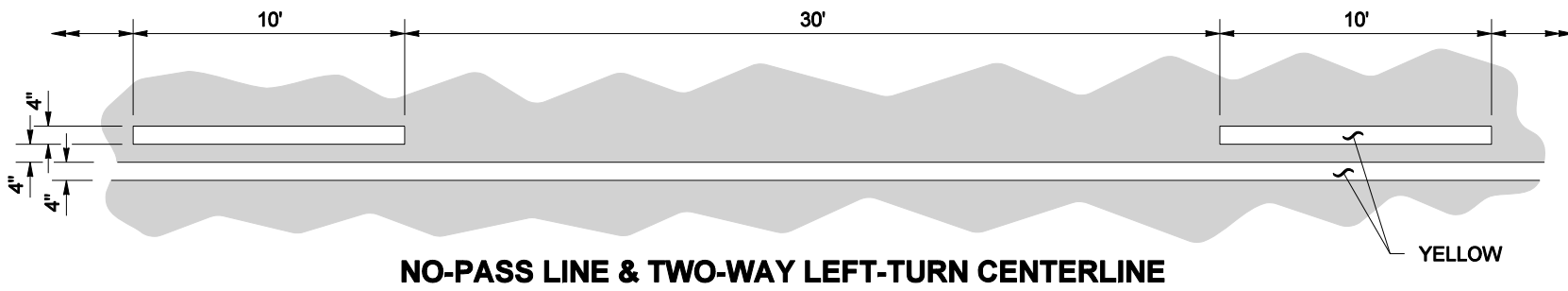
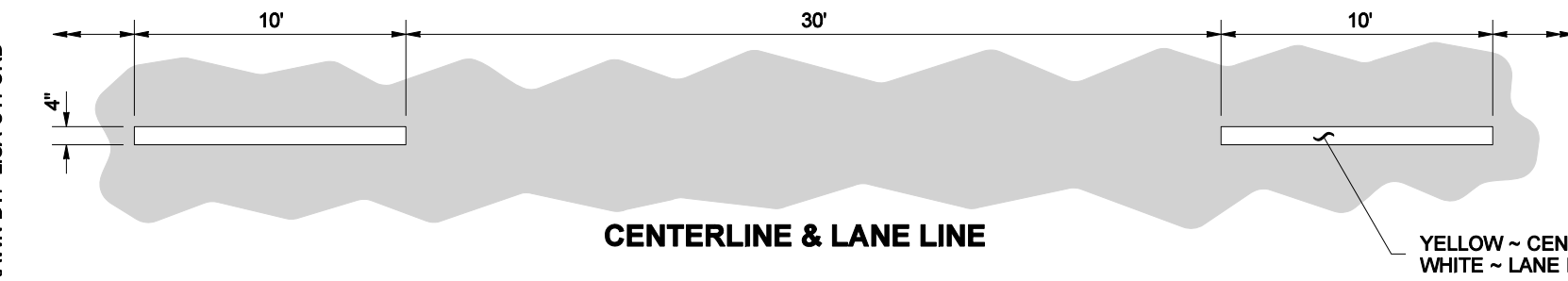

NOTES

1. Dotted Extension Line shall be the same color as the line it is extending.
2. Edge Line shall be white on the right edge of traveled way, and yellow on the left edge of traveled way (on one-way roadways). Solid Lane Line shall be white.
3. The distance between the lines of the Double Centerline shall be 12" everywhere, except 4" for left-turn channelization and narrow roadways with lane widths of 10 feet or less. Local Agencies (on non-state routes) may specify a 4" distance for all locations. The distance between the lines of the Double Lane Line shall be 4".

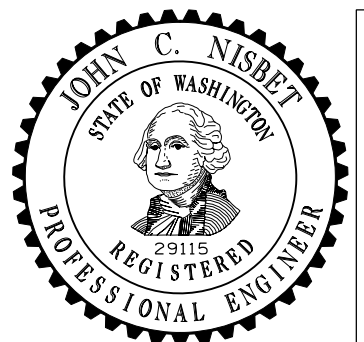

NOTE: THIS PLAN IS NOT A LEGAL ENGINEERING DOCUMENT UNTIL IT IS APPROVED BY THE ENGINEER. THE ENGINEER'S APPROVAL IS VALID ONLY IF THE ENGINEER HAS FILED AT THE WASHINGTON STATE DEPARTMENT OF TRANSPORTATION. A COPY MAY BE OBTAINED UPON REQUEST.

LONGITUDINAL MARKING PATTERNS

STANDARD PLAN M-20.10-02

SHEET 1 OF 1 SHEET

APPROVED FOR PUBLICATION

Pasco Bakotich III 06-03-11

STATE DESIGN ENGINEER DATE



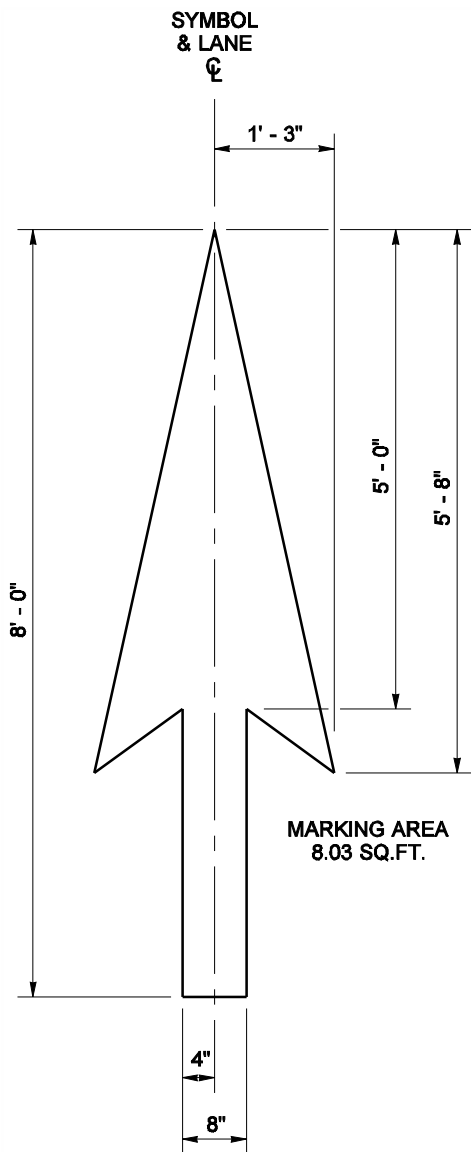

**TYPE 1S
TRAFFIC ARROW**

MARKING AREA
8.03 SQ.FT.

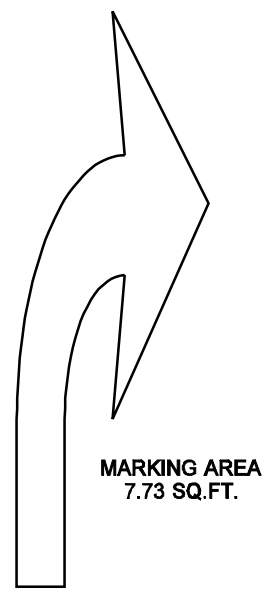

MARKING AREA
7.73 SQ.FT.

**TYPE 2SR (RIGHT)
TRAFFIC ARROW**
MIRROR IMAGE OF
TYPE 2SL TRAFFIC ARROW
(SHOWN AT REDUCED SCALE)

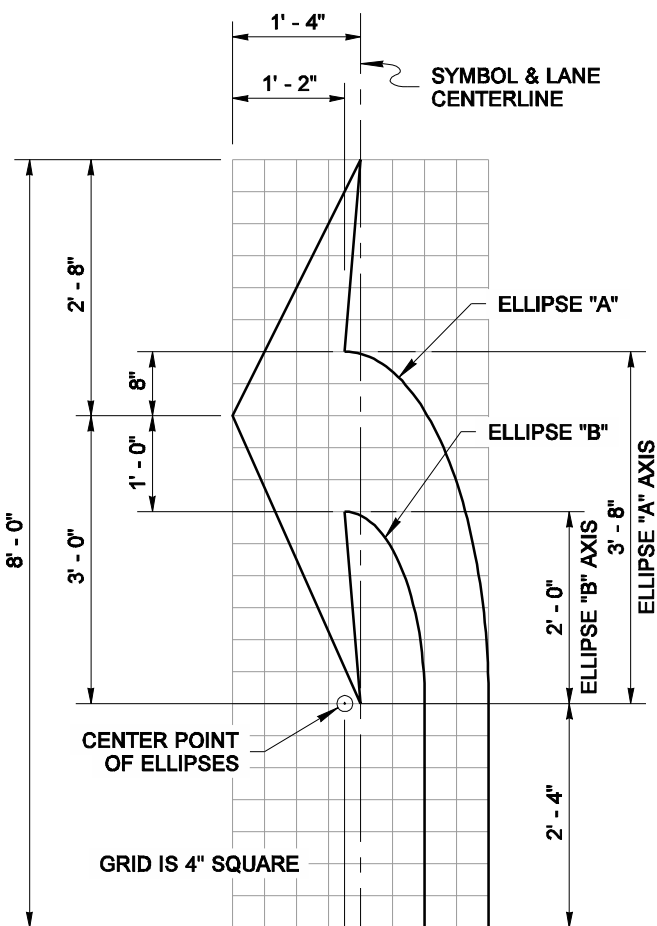

MARKING AREA
7.73 SQ.FT.

TYPE 2SL (LEFT) TRAFFIC ARROW

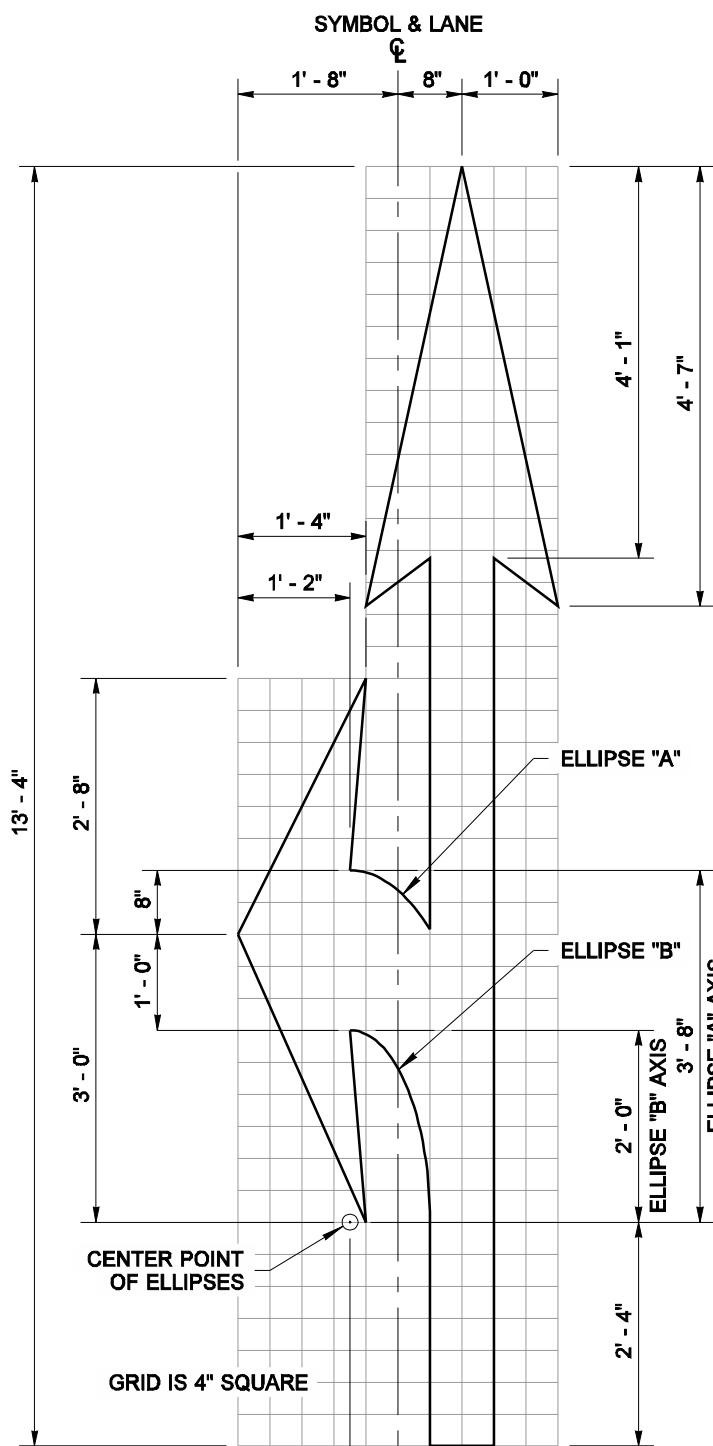

MARKING AREA
14.83 SQ.FT.

TYPE 3SL (LEFT) TRAFFIC ARROW

NOTE

Use the dimensions shown on this plan for each type Traffic Arrow being placed on roadways with a posted speed limit of 40 mph or lower.

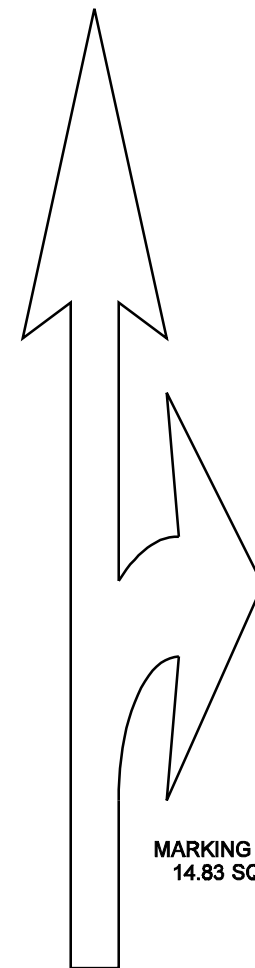

MARKING AREA
14.83 SQ.FT.

**TYPE 3SR (RIGHT)
TRAFFIC ARROW**
MIRROR IMAGE OF
TYPE 3SL TRAFFIC ARROW
(SHOWN AT REDUCED SCALE)

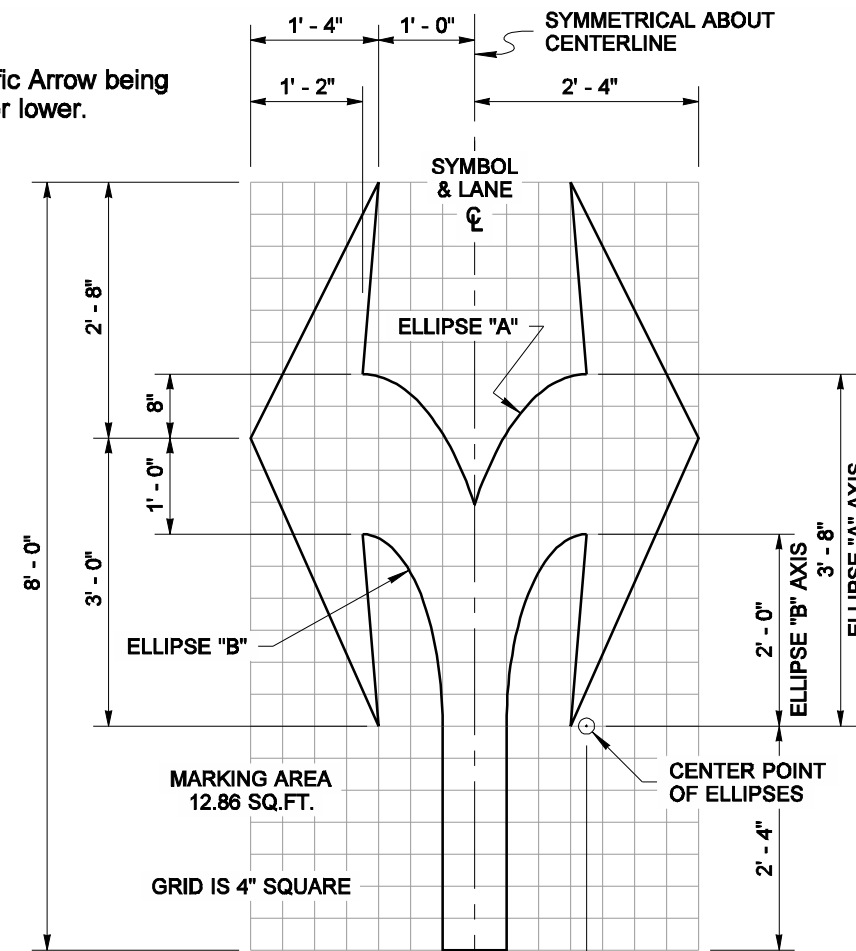

MARKING AREA
12.86 SQ.FT.

**TYPE 4S
TRAFFIC ARROW**

DRAWN BY: MARK SUJKA



EXPIRES AUGUST 9, 2007

**SYMBOL MARKINGS
TRAFFIC ARROWS FOR
LOW SPEED ROADWAYS
STANDARD PLAN M-24.40-01**

SHEET 1 OF 2 SHEETS

APPROVED FOR PUBLICATION

Harold J. Peterfeso 05-31-06

STATE DESIGN ENGINEER

DATE



Washington State Department of Transportation

NOTE: THIS PLAN IS NOT A LEGAL ENGINEERING DOCUMENT BUT AN ELECTRONIC DIGITAL FILE. THE ORIGINAL, SIGNED BY THE ENGINEER AND APPROVED FOR PUBLICATION, IS KEPT ON FILE AT THE WASHINGTON STATE DEPARTMENT OF TRANSPORTATION. A COPY MAY BE OBTAINED UPON REQUEST.

DRAWN BY: MARK SUJKA

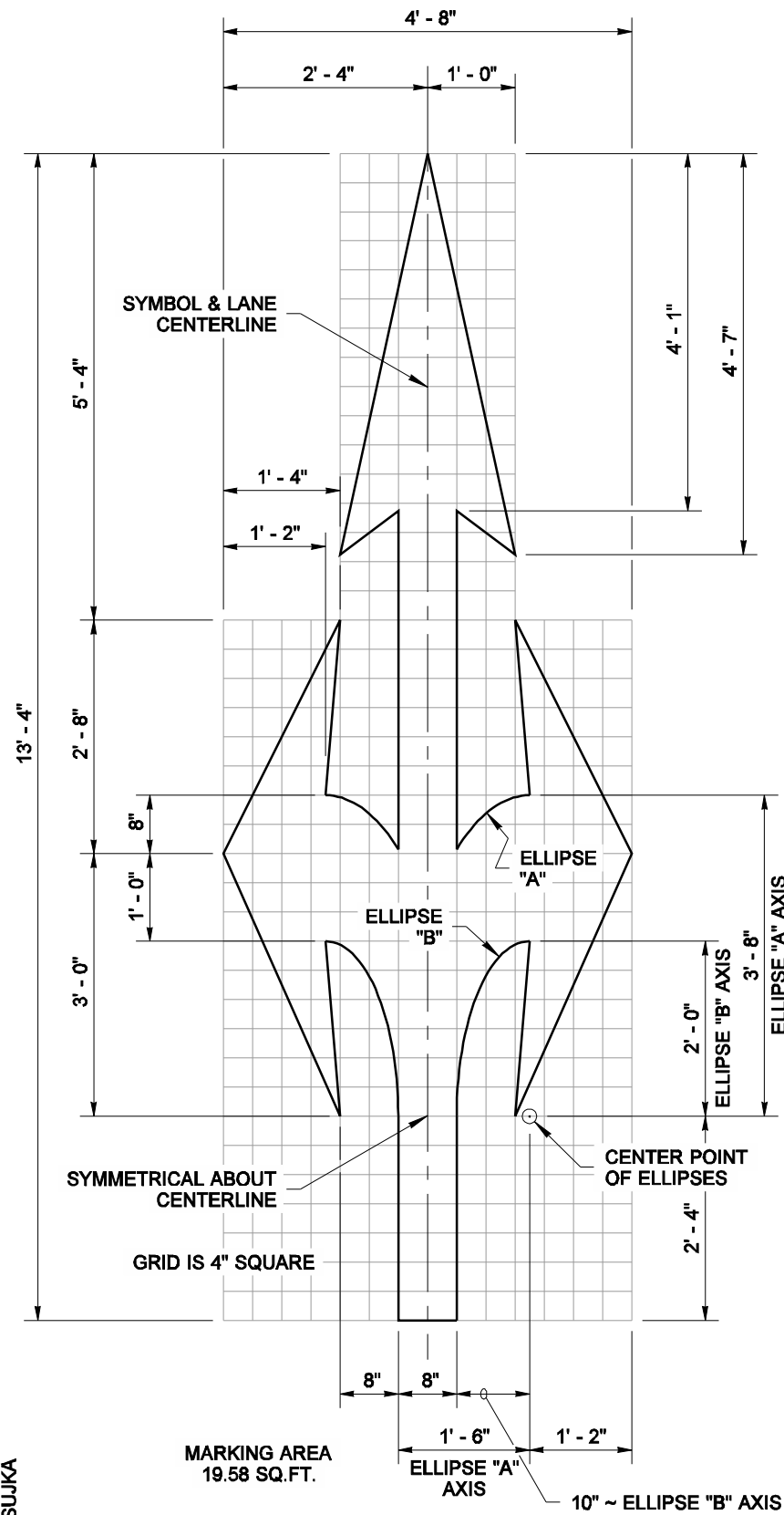

TYPE 7S TRAFFIC ARROW

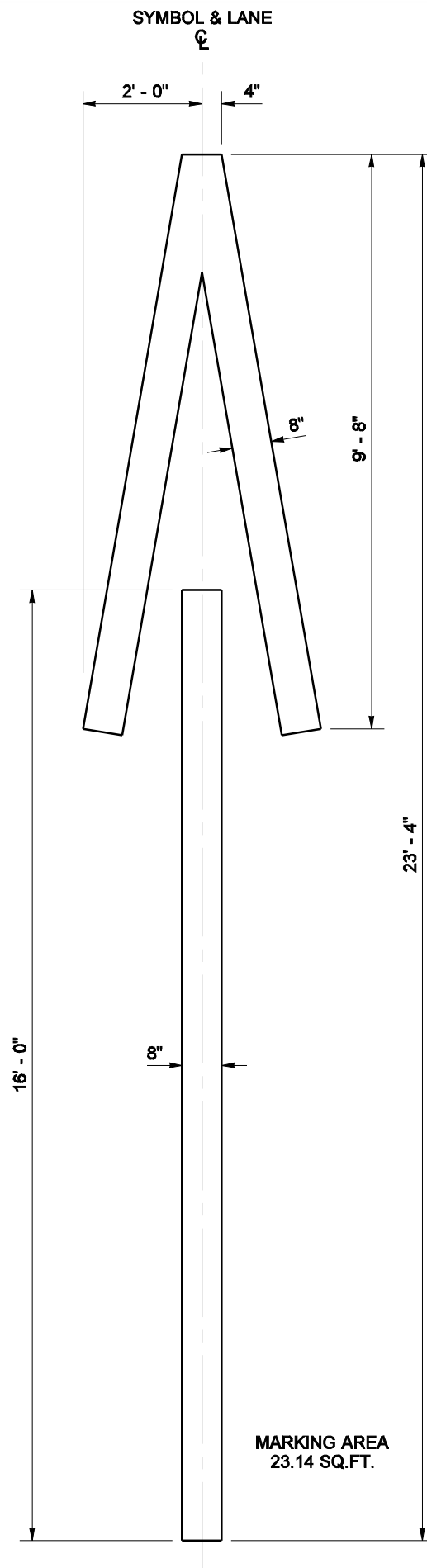

TYPE 5 TRAFFIC ARROW

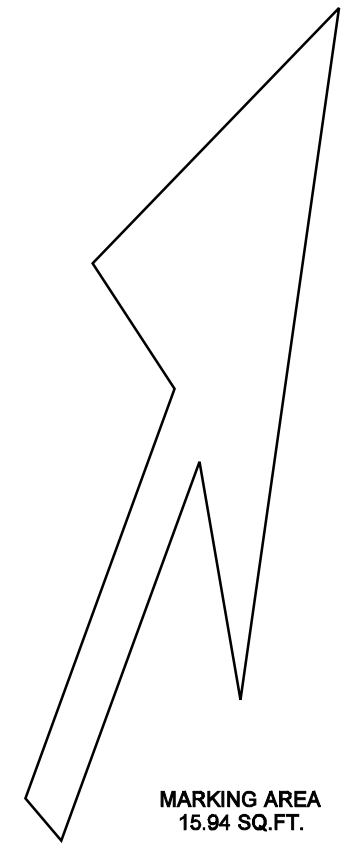
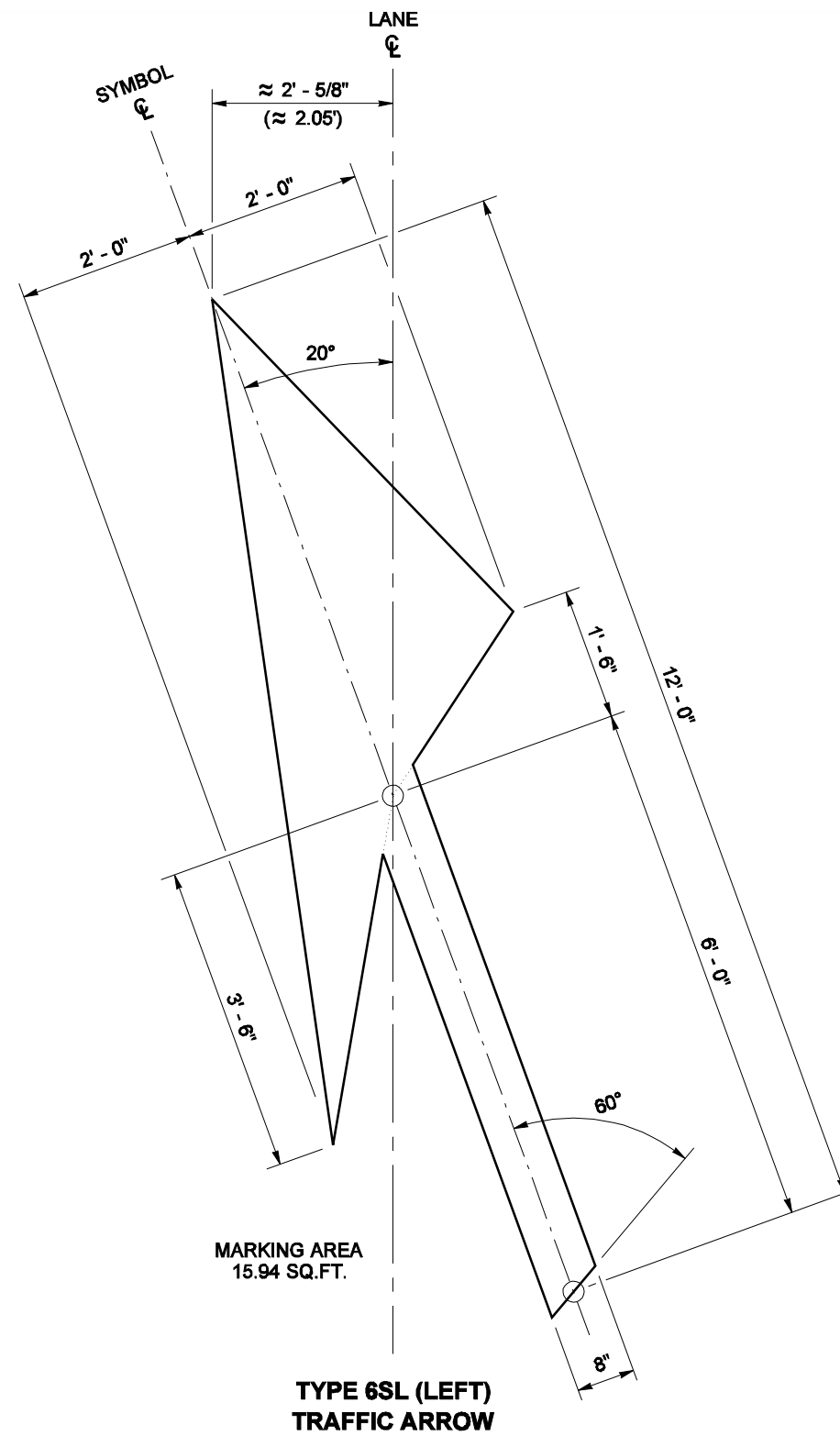

TYPE 6SR (RIGHT) TRAFFIC ARROW
MIRROR IMAGE OF TYPE 6SL (MIRRORED ABOUT LANE CENTERLINE) (SHOWN AT REDUCED SCALE)



EXPIRES AUGUST 9, 2007

SYMBOL MARKINGS TRAFFIC ARROWS FOR LOW SPEED ROADWAYS STANDARD PLAN M-24.40-01

SHEET 2 OF 2 SHEETS

APPROVED FOR PUBLICATION

Harold J. Peterfeso 05-31-06

STATE DESIGN ENGINEER DATE



NOTE: THIS PLAN IS NOT A LEGAL ENGINEERING DOCUMENT BUT AN ELECTRONIC DUPLICATE. THE ORIGINAL, SIGNED BY THE ENGINEER AND APPROVED FOR PUBLICATION, IS KEPT ON FILE AT THE WASHINGTON STATE DEPARTMENT OF TRANSPORTATION. A COPY MAY BE OBTAINED UPON REQUEST.

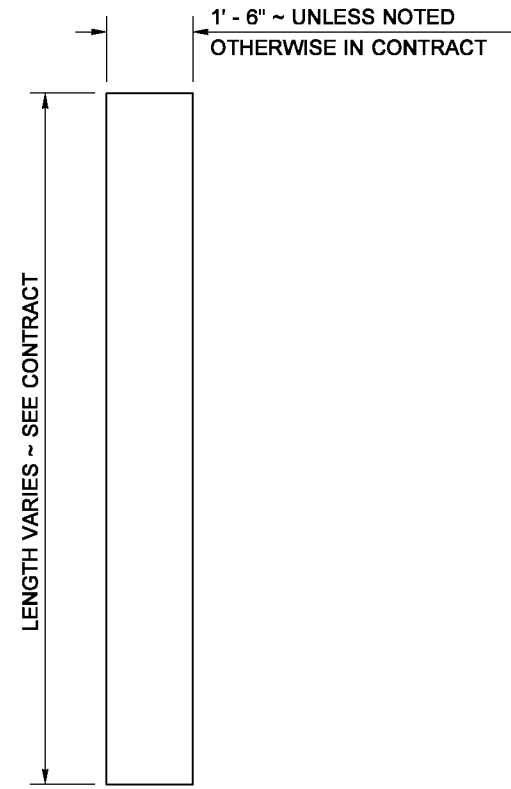

STOP LINE

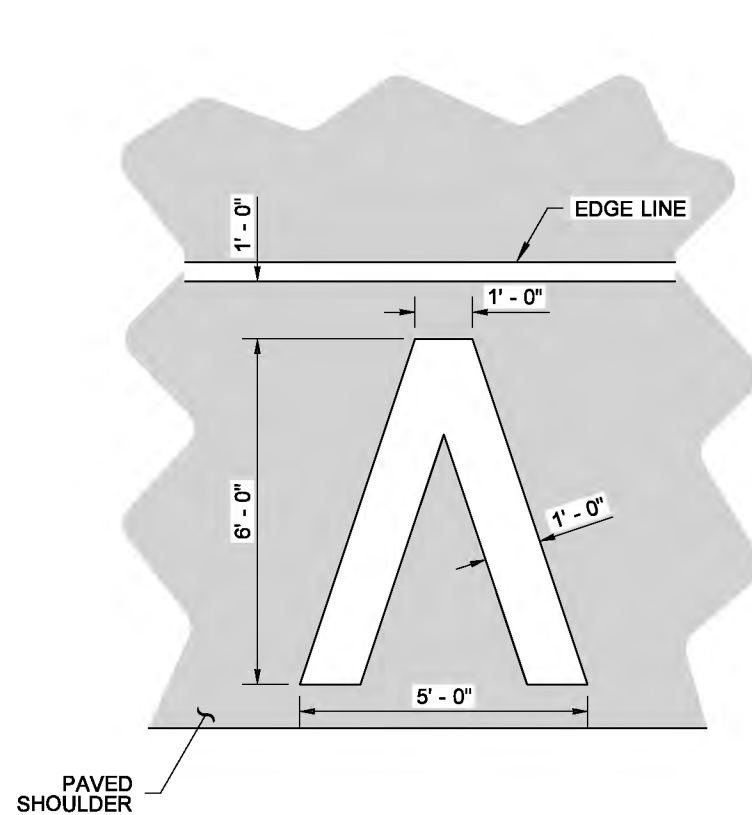

MARKING AREA = 11.73 SQ.FT.
HALF-MILE MARKER

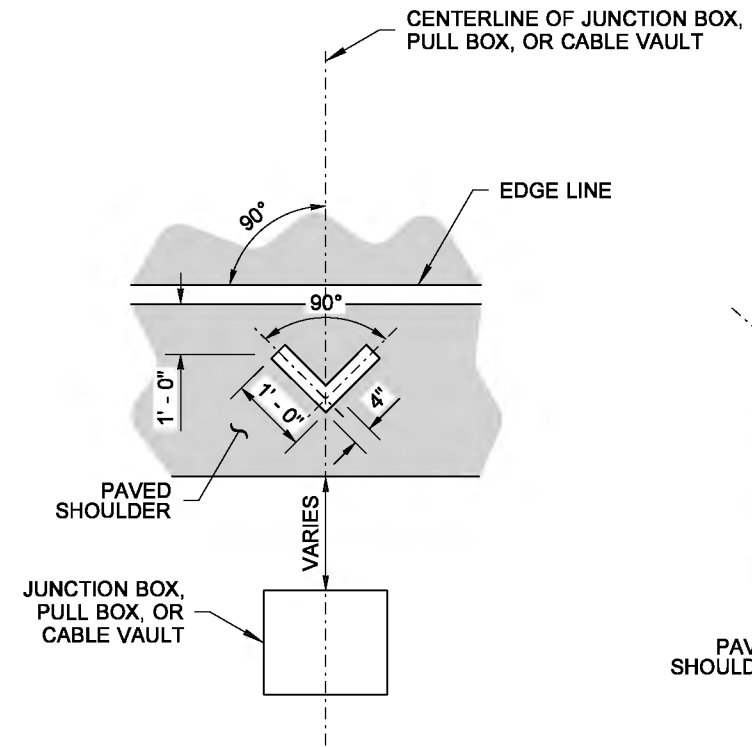

MARKING AREA = 0.56 SQ. FT.
**JUNCTION BOX, PULL BOX,
OR CABLE VAULT MARKINGS**

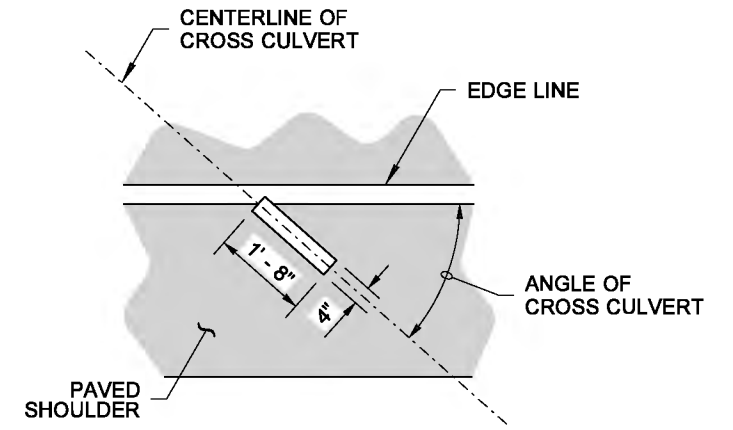

MARKING AREA = 0.56 SQ.FT.
CROSS CULVERT

DRAINAGE MARKING

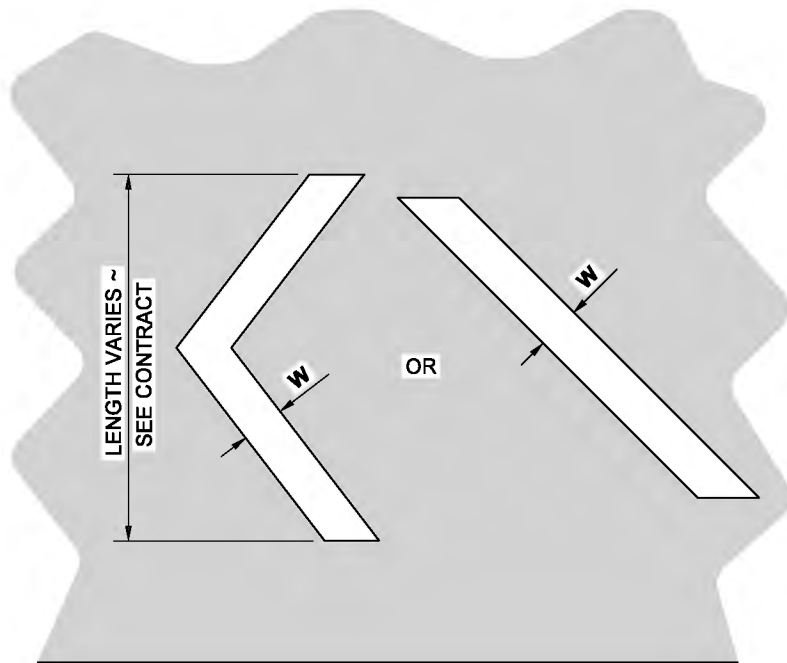

WHITE OR YELLOW ~ SEE CONTRACT
CHEVRON OR DIAGONAL

CROSSHATCH MARKING

W = 8" (IN) FOR POSTED SPEED LIMIT OF 40 MPH OR LOWER
W = 12" (IN) FOR POSTED SPEED LIMIT OF 45 MPH OR HIGHER

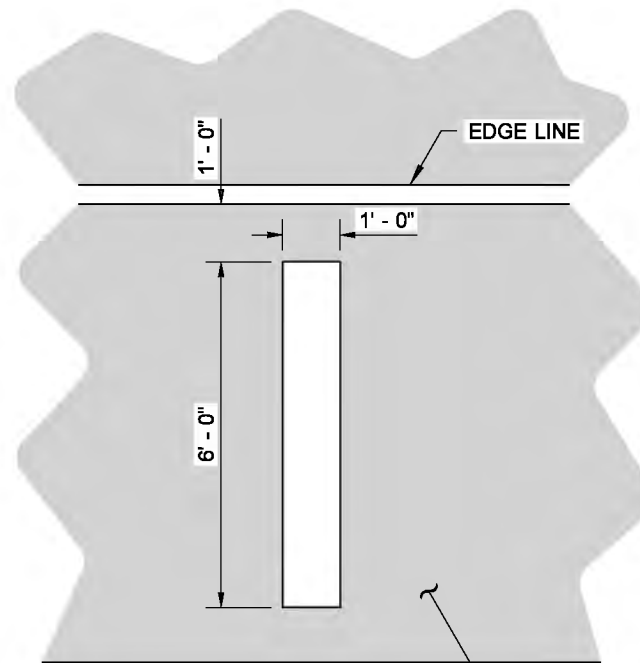

MARKING AREA = 6.00 SQ.FT.
FULL MILE MARKER

AERIAL SURVEILLANCE MARKERS

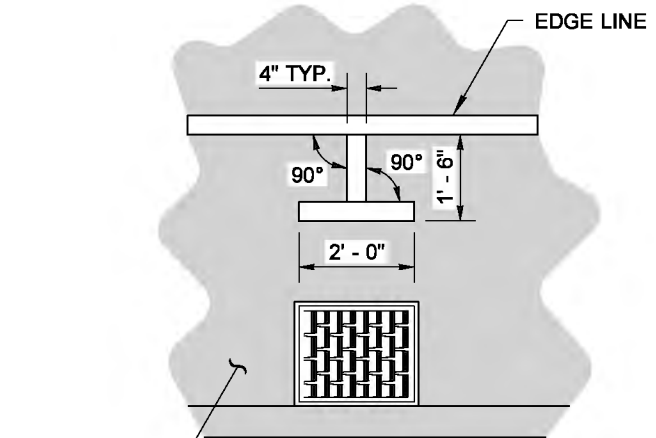

MARKING AREA = 1.06 SQ.FT.
DRAINAGE STRUCTURE INLET

DRAINAGE MARKING

NOTE

1. If Rumble Strips are present, install marking outside of the Rumble Strip.



**SYMBOL MARKINGS
MISCELLANEOUS**

STANDARD PLAN M-24.60-04

SHEET 1 OF 2 SHEETS

APPROVED FOR PUBLICATION

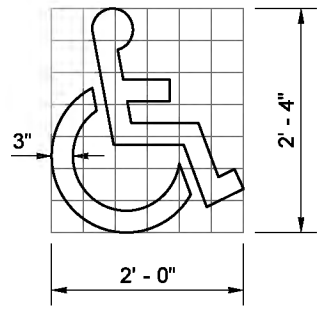

GRID IS 4" (IN) SQUARE MARKING AREA = 1.41 SQ.FT.
ACCESS PARKING SPACE SYMBOL (MINIMUM)

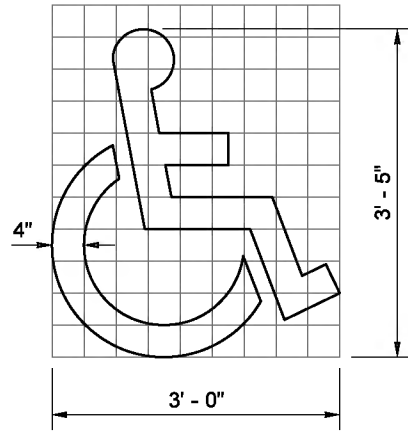

GRID IS 4" (IN) SQUARE MARKING AREA = 3.09 SQ.FT.
ACCESS PARKING SPACE SYMBOL (STANDARD)

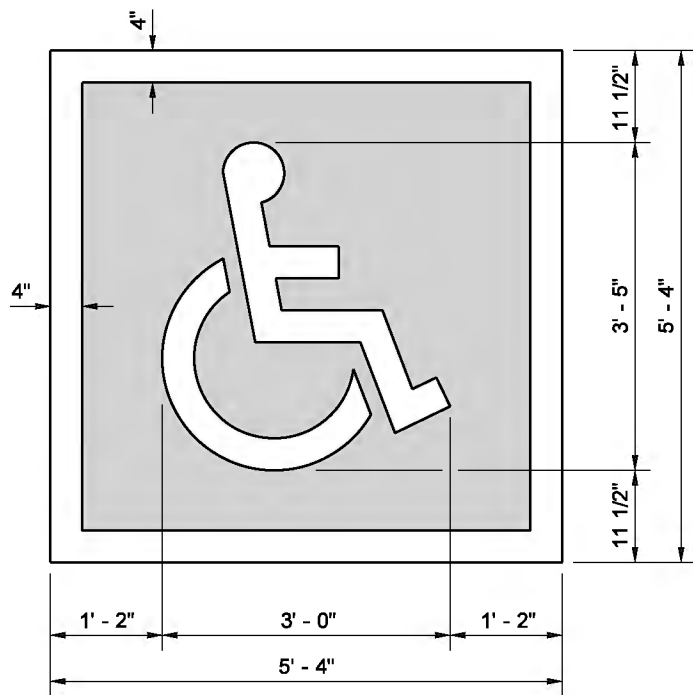

TOTAL MARKING AREA = 28.44 SQ.FT.
 WHITE = 9.76 SQ.FT. BLUE = 18.69 SQ.FT.
ACCESS PARKING SPACE SYMBOL (STANDARD) WITH BLUE BACKGROUND AND WHITE BORDER (REQUIRED FOR CEMENT CONCRETE SURFACES)

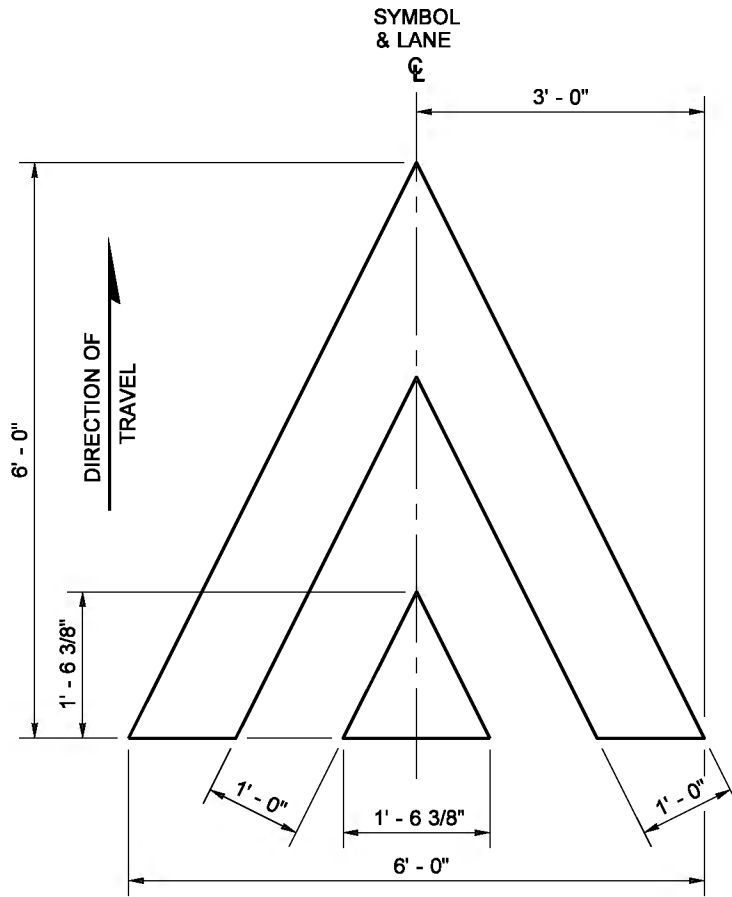

MARKING AREA = 12.08 SQ.FT.
SPEED BUMP SYMBOL

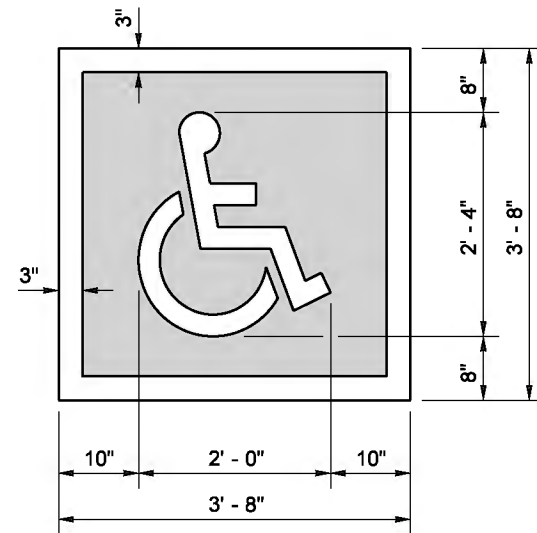

TOTAL MARKING AREA = 13.44 SQ.FT.
 WHITE = 4.82 SQ.FT. BLUE = 8.62 SQ.FT.
ACCESS PARKING SPACE SYMBOL (MINIMUM) WITH BLUE BACKGROUND AND WHITE BORDER (REQUIRED FOR CEMENT CONCRETE SURFACES)

SYMBOL MARKING		A	B	C	D	USE	MARKING AREA
YIELD AHEAD SYMBOL	TYPE 1	6' - 0"	2' - 6"	13' - 0"	N/A	LESS THAN 45 MPH	25.90 SQ.FT.
	TYPE 2	6' - 0"	3' - 0"	20' - 0"	N/A	45 MPH OR GREATER	36.54 SQ.FT.
YIELD LINE SYMBOL	TYPE 1	1' - 0"	6"	1' - 6"	6"	LESS THAN 45 MPH	0.75 SQ.FT.
	TYPE 2	2' - 0"	1' - 0"	3' - 0"	1' - 0"	45 MPH OR GREATER	3.00 SQ.FT.
	TYPE 2	2' - 0"	1' - 0"	3' - 0"	1' - 0"	ROUNDBOUNT ENTRY *	3.00 SQ.FT.

* MINIMUM OF 4 IN LANE

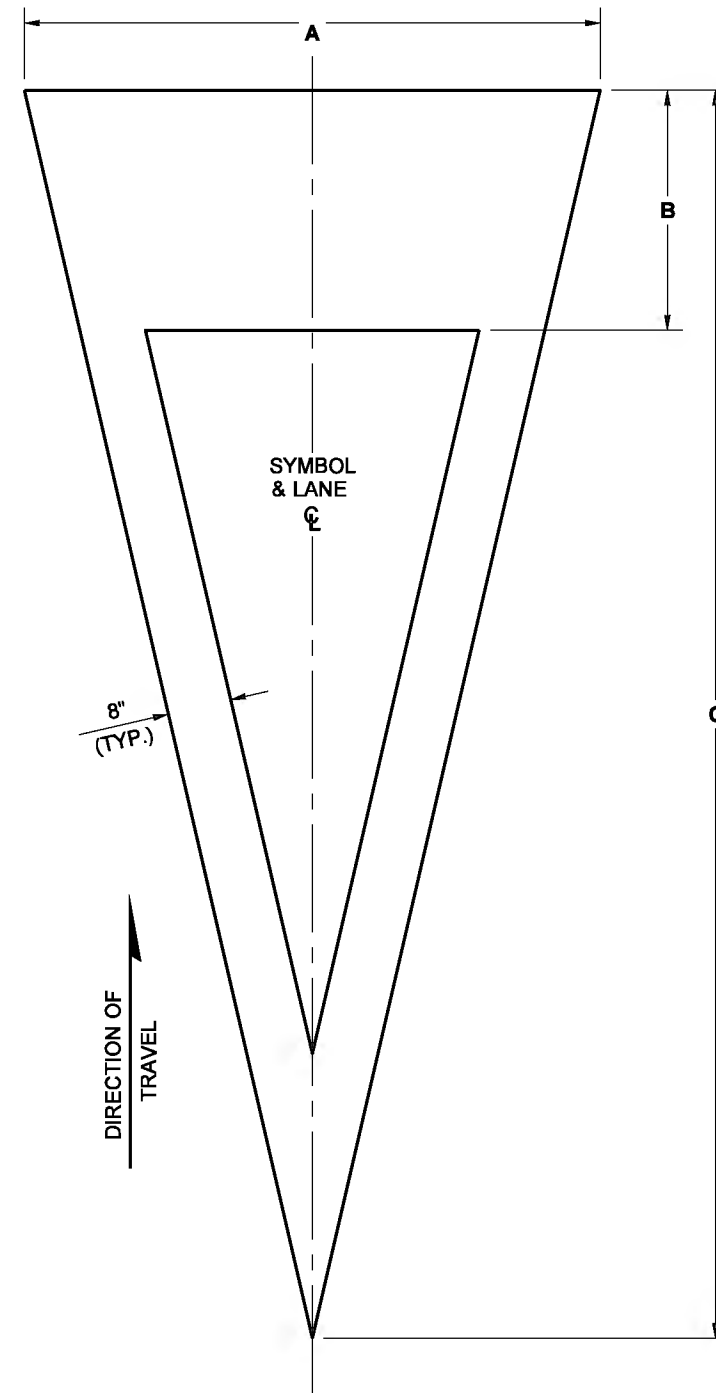

YIELD AHEAD SYMBOL

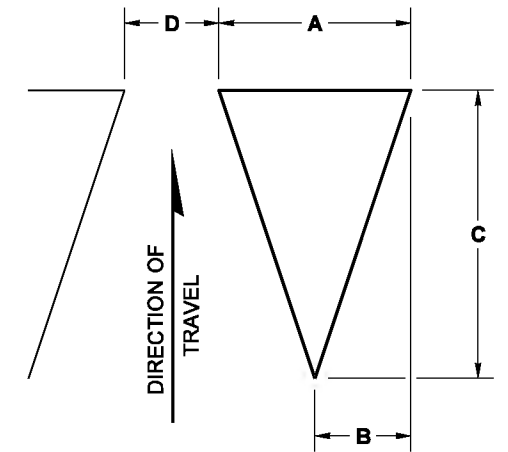

YIELD LINE SYMBOL (MULTIPLE SYMBOLS REQUIRED FOR TRANSVERSE YIELD LINE - SEE CONTRACT)



SYMBOL MARKINGS MISCELLANEOUS
STANDARD PLAN M-24.60-04

SHEET 2 OF 2 SHEETS

APPROVED FOR PUBLICATION

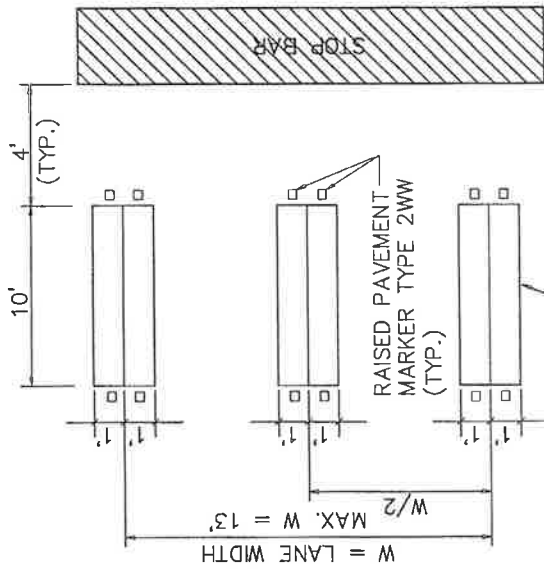

WHITE THERMOPLASTIC
OR PAINT
STANDARD 10 FT. CROSSWALK

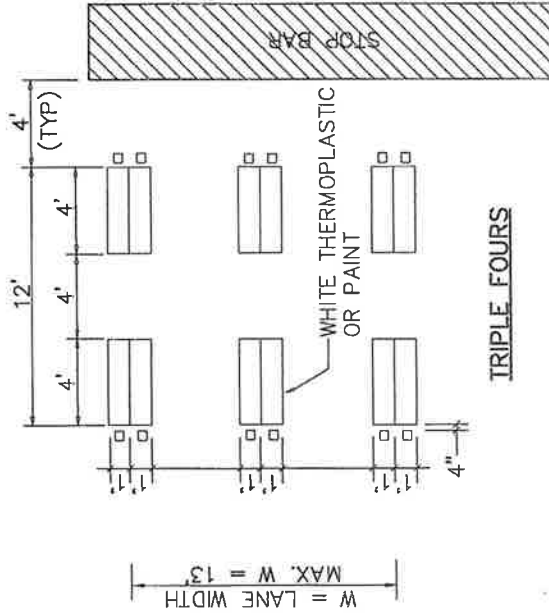

TRIPLE FOURS



SNOHOMISH COUNTY PUBLIC WORKS

7-110

CROSSWALK DETAIL

APPROVED BY:

Steven E. Johnson 2-10-03

COUNTY ROAD ENGINEER

DATE

