

Stack Short Plat

Preliminary Drainage Report

Prepared for

Stack Design, LLC

8825 34th Ave NE, Suite L-410
Marysville, WA 98271

Prepared by

LDC, Inc.

20210 142nd Ave NE
Woodinville, WA 98072
(425) 806-1869

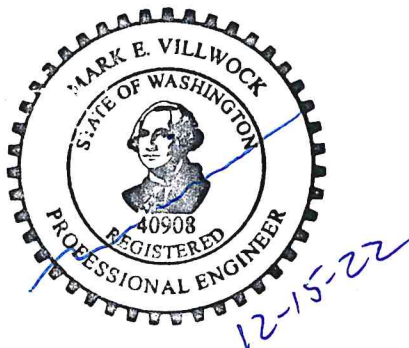

December 2022

Job No: C22-144

TABLE OF CONTENTS

Section	Title	
1	Project Overview	1-1
2	Risk Assessment Analysis and Temporary Erosion and Sediment Control Analysis and Design	2-1
3	Downstream Analysis	3-1
4	Detention and Water Quality Facility Analysis and Design	4-1
5	Conveyance Analysis and Design	5-1
6	Operations and Maintenance Manual	6-1
7	Special Reports and Studies	7-1

APPENDICES

#	Title
1	Project Overview
3	Resource Review
4	Site Hydrology, Infiltration, and Water Quality Facility Analysis
5	Conveyance Data and Analysis

SECTION I: PROJECT OVERVIEW

The proposed Stack Short Plat project consists of parcel #30050900202200, located at 3807 122nd St NE in Marysville, WA. The project proposes the development of 5 new single-family lots, along with associated accesses and utilities on the 1.31-acre site. In addition to onsite development, the project proposes frontage improvements along the northern margin of 122nd St NE, to include minor pavement widening and construction of new sidewalk. See Vicinity Map in Appendix 1 for relative location.

EXISTING SITE

The existing site is made up of parcel #30050900202200, totaling 1.31 acres. The parcel is currently developed with one single-family residence and two outbuildings, along with associate drive accesses. Some tree cover is present immediately surrounding the home and outbuildings, while the remainder of the parcel is maintained as lawn/landscaped area.

According to USDA Soil Mapping, site soils consist primarily of Custer Fine Sandy Loam, a Hydrologic Group C/D soil which is primarily associated with glacial outwash deposits. USGS surficial mapping (*Distribution and description of the geologic units in the Marysville quadrangle, Washington, prepared by J.P. Minard, 1980*) is consistent with these findings, indicating Vashon recessional outwash (Marysville sand member) throughout the project site and surrounding areas. Geotechnical analysis prepared by Terra Associates, Inc. (dated August 31, 2022) indicates approximately 6 to 9 inches of organic topsoil underlain by 1.5 to 5 feet of loose to medium dense, fine to course-grained sand and gravel. Groundwater and mottling/oxidation staining was observed as shallow ad 9 to 12 inches below grade at the northwest corner of the site, and as deep as 5 feet below grade on the southern portion of the site.

Due to the presence of shallow groundwater, full infiltration of developed flows is not considered feasible across the site. However, geotechnical analysis does indicate that limited infiltration may be utilized in areas where deeper groundwater is observed near the southern and eastern portions of the site. A preliminary design infiltration

rates of 0.3 in/hr is recommended for these systems, subject to further infiltration testing.

DOWNSTREAM ANALYSIS

The site lies within a single threshold discharge area and contains a single natural discharge point at its southwestern margin. In the existing condition, site runoff flows generally westward as sheet flow over gentle slopes and collects within an existing drainage swale which runs north-south along the western property boundary. Flow conveys southward within the existing swale and discharges to the existing City of Marysville stormwater conveyance system near the southwestern corner of the site, at the northern margin of 122nd St NE. The existing City conveyance system carries flow southward across 122nd St NE, where it redirects westward. Flow continues westward along the southern margin of 122nd St NE for approximately 950 LF, before discharging to the I-5 ROW near the intersection of 122nd St NE and 35th Ave NE. Flow continues southward for approximately 850 LF within the existing drainage swales along the eastern margin of I-5 before exiting the 0.25-mile boundary of analysis. All flow emanating from the site eventually discharges to Quilceda Creek, which in turn outlets to Possession Sound.

For a detailed analysis of existing flowpath(s) downstream of the site discharge point, see the narrative in Section 3.0 along with Figure 3.0, “Downstream Analysis Map”.

PROPOSED DEVELOPMENT

The Stack Short Plat project proposes the development of 5 new single-family lots, along with associated accesses and utilities on the 1.31-acre site. Additionally, the project proposes frontage improvements along the northern margin of 122nd St NE, to include minor pavement widening and construction of new sidewalk. In total, the project will disturb 1.285 acres and create 0.69 acres of new impervious surfaces.

This project is vested under the 2019 DOE Manual, and the City of Marysville Engineering Design and Development Standards (EDDS).

PROPOSED DRAINAGE SYSTEM

Stormwater management for this project adheres to the requirements of the 2019 Stormwater Management Manual for Western Washington (SWMMWW). In compliance with the requirements of the DOE Manual, runoff from developed/disturbed surfaces will be collected, treated and infiltrated/otherwise released to natural drainage courses at allowable rates. Stormwater management for this project will be achieved by means of two infiltration galleries, located near the southern and northeastern portions of the site. Infiltration gallery #1, located near the western edge of the proposed access road at the southern margin of the site, will collect and partially infiltrate all onsite flows, with the exception of roof areas associated with Lot 5. This area will be routed to infiltration gallery #2, located near the northeastern portion of the site.

Due to spatial constraints and limited depth to restrictive features onsite, full infiltration of all developed flows is infeasible. The proposed gallery facilities will infiltrate approximately 99% of incoming flows, while the remaining flow will be discharged through respective overflow structures to the existing City of Marysville stormwater conveyance system located at the eastern and southwestern margins of the site. As calculated 100-year peak bypass flows represent less than 0.15cfs increase relative to the predeveloped condition, additional flow control facilities will not be provided.

Infiltration and associated peak flow calculations have been completed using WWHM2012. See Section 4.0 for additional description and calculations concerning the proposed stormwater flow control measures.

WATER QUALITY

The single-family nature of the development requires a basic water quality treatment level. Basic water quality treatment will be achieved by means of a StormFilter Manhole cartridge filtration structure located upstream of Infiltration Gallery 1. Further discussion of the proposed water quality structure can be found in Section 4.2.

EROSION/SEDIMENTATION CONTROL

Erosion control measures that will be utilized during construction will include a combination of silt fence, storm drain inlet protection, interceptor swales, and a temporary sediment pond. A TESC plan and SWPPP report detailing proposed erosion control measures will be provided as part of a forthcoming construction plan submittal. See Section 2.0 for preliminary discussion of how SWPPP Elements will be addressed.

MINIMUM REQUIREMENTS

Per the 2019 DOE Manual, Minimum Requirements 1-9 apply to the proposed development.

Minimum Requirement #1: Preparation of Stormwater Site Plans: This Report along with the Preliminary Plans satisfies this minimum requirement.

Minimum Requirement #2: Construction Stormwater Pollution Prevention: See Section 2 of this Report for preliminary discussion of proposed SWPPP BMP Elements. A SWPPP report and associated TESC plan will be provided as part of a forthcoming construction submittal.

Minimum Requirement #3: Source Control of Pollution: Permanent source control BMPs are not applicable for the subject site since the associated activities for the new residence do not fall within the types of facilities listed within the DOE manual.

Minimum Requirement #4: Preservation of Natural Drainage Systems and Outfalls:

The site contains one onsite discharge location that lies within a single threshold discharge basin. Existing runoff conveys westward/southwestward across the site and discharges to the existing City of Marysville conveyance system beneath 122nd St NE.

In the developed condition, site runoff will be collected and infiltrated onsite to the extent feasible. Peak flows in excess of infiltration system capabilities, as well as bypassed frontage areas, will be released to the existing City conveyance system in a manner consistent with the predeveloped flowpath.

Minimum Requirement #5: Onsite Stormwater Management:

This project is required to comply with List #2: Onsite Stormwater Management BMPs for Projects Triggering Minimum Requirements #1 through #9. To accomplish this, stormwater management BMPs were assessed for feasibility in the order that they appeared, with the highest priority BMPs selected for lawn, roof, and other hard surfaces as applicable to the project.

In general, BMP T5.13 (Post-Construction Soil Quality and Depth) was deemed feasible for this project, and will be applied to all disturbed areas which are classified as pervious in the developed condition.

Due to the extent of clearing/grading and spatial constraints associated with the proposed development, it was determined that dispersion BMPs (including Full Dispersion) are generally unsuitable for this project. In addition, shallow groundwater observed at various locations throughout the site precludes the use of full infiltration. However, geotechnical analysis does indicate that limited infiltration may be utilized in areas where deeper groundwater is observed near the southern and eastern portions of the site. A preliminary design infiltration rates of 0.3 in/hr is recommended for these systems, subject to further infiltration testing.

In accordance with geotechnical recommendations, developed condition flows will be collected and routed to one of two infiltration galleries, located at the southern and northeastern margins of the site. The proposed galleries will infiltrate approximately 99% of incoming flows, while remaining flows in excess of the provided capacity will discharge through an associated overflow structure to the existing City stormwater conveyance system.

Please refer to Appendix 1 for a copy of List #2 BMPs in the order required for consideration by the 2019 DOE Manual, as well as associated feasibility/infeasibility criteria.

Minimum Requirement #6: Runoff Treatment: As this project proposes a single-family development, basic treatment is required. The project proposes a StormFilter Manhole cartridge filtration structure located upstream of Infiltration Gallery #1, which will provide treatment for all PGIS areas onsite. Due to topographic constraints, flows associated with proposed frontage improvements cannot be collected and will bypass the proposed treatment facility in the developed condition. As bypassed PGIS falls below the 5,000sf threshold for water quality treatment, no additional measures will be required. See Onsite Stormwater Analysis in Section 4.0 of this report for further discussion.

Minimum Requirement #7: Flow Control: Stormwater management for this project will be achieved by means of two infiltration galleries, located near the southern and northeastern portions of the site. Infiltration Gallery #1, located near the western edge of the proposed access road at the southern margin of the site, will collect and partially infiltrate all onsite flows, with the exception of roof areas associated with Lot 5. This area will be routed to Infiltration Gallery #2, located near the northeastern portion of the site.

Due to spatial constraints and limited depth to restrictive features onsite, full infiltration of all developed flows is infeasible. The proposed gallery facilities will

infiltrate approximately 99% of incoming flows, while the remaining flow will be discharged through respective overflow structures to the existing City of Marysville stormwater conveyance system located at the eastern and southwestern margins of the site. As calculated 100-year peak bypass flows represent less than 0.15cfs increase relative to the predeveloped condition, additional flow control facilities will not be required.

Infiltration and associated peak flow calculations have been completed using WWHM2012. See Section 4.0 for additional description and calculations concerning the proposed stormwater flow control measures.

Minimum Requirement #8: Wetlands Protection: No wetlands or associated buffer areas have been located on or immediately adjacent to the site.

Minimum Requirement #9: Operation and Maintenance: See Operations and Maintenance in Section 5.0 of this report.

Appendix 1: Project Overview

1. Figure 1.0 - Vicinity Map
2. Figure 2.0 - Existing Conditions Map
3. List #2 Feasibility Matrix

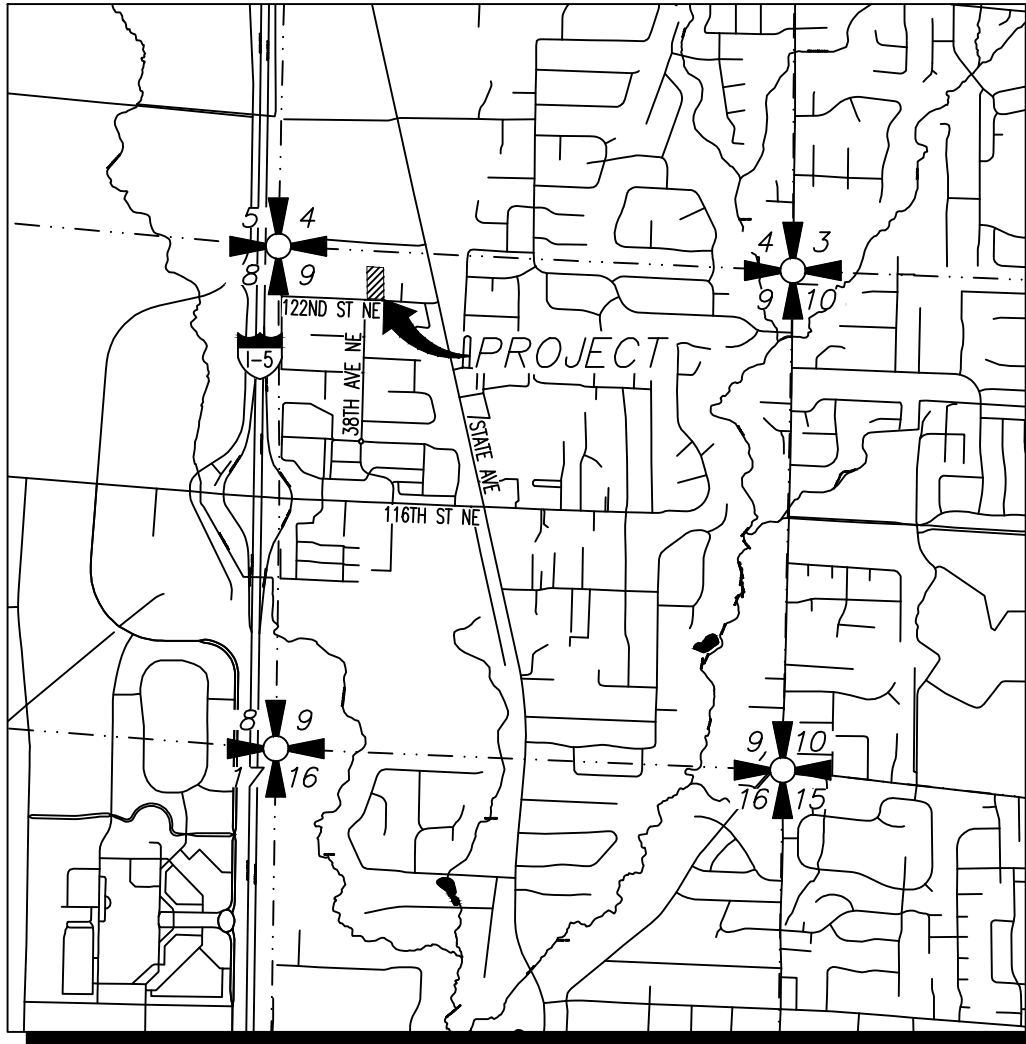

VICINITY MAP

SCALE: 1"=2000'

LDC

Surveying
Engineering
Planning

Kent Woodinville Olympia

20210 142nd Avenue NE
Woodinville, WA 98072

T 425.806.1869

www.LDCcorp.com

F 425.482.2893

STACK DESIGN & CONSTRUCTION, LLC

STACK SHORT PLAT

VICINITY MAP

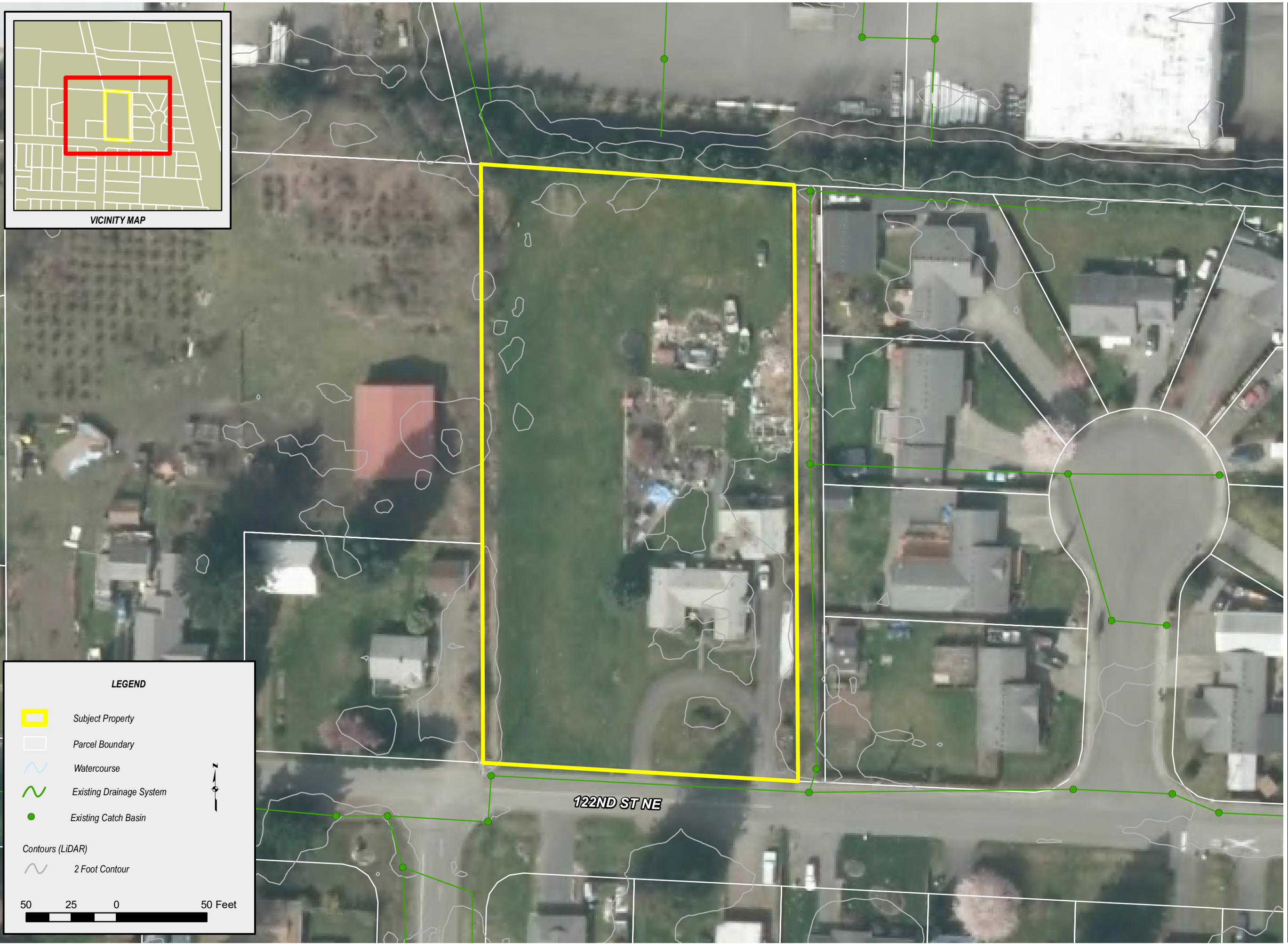

LEGEND

- Subject Property
- Parcel Boundary
- ~ Watercourse
- ~ Existing Drainage System
- Existing Catch Basin

Contours (LiDAR)

- ~ 2 Foot Contour

50 25 0 50 Feet

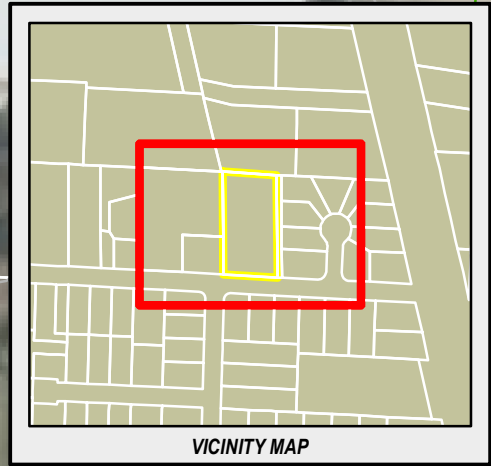

STACK DESIGN AND CONSTRUCTION, LLC

**STACK SHORT PLAT
EXISTING CONDITIONS MAP**

NAD 1983 HARN
STATEPLANE WASHINGTON
NORTH FIPS 4601 FEET

REVISION:
JOB NUMBER: C22-144
DRAWING NAME: C22-144-2.0
DESIGNER: JSMITH
DRAWING BY: SWILSON
DATE: 9/9/2022
SCALE: AS SHOWN
JURISDICTION: MARYSVILLE

**FIGURE:
2.0**

LDC

Woodinville
20210 142nd Avenue NE
Woodinville, WA 98072
T: 425.806.1869 www.LDCcorp.com

Kent
1851 Central Pl S, #101
Kent, WA 98030
F: 425.482.2893

SOURCE AGENCY	DESCRIPTION
SNHOMISH COUNTY GIS	PARCEL BOUNDARY
SNHOMISH COUNTY GIS	CONTOURS GENERATED FROM BARE EARTH LIDAR (KING COUNTY). THIS DATA HAS A STATED VERTICAL ACCURACY OF APPROXIMATELY 1 FOOT.

Date: 9/9/2022
 LDC Project No: C22-144
 Project Name: Stack Short Plat

List #2 Summary Matrix				
BMP #	BMP Name	BMP Criteria	Feasible or Infeasible	Comment
Lawn and Landscaped Areas:				
T5.13	Post-Construction Soil Quality and Depth	Establish minimum soil quality and depth to provide increased stormwater and pollutant removal function.	Feasible	All pervious areas will be amended, as necessary, in accordance with BMP T5.13.
Roofs:				
T5.30	Full Dispersion	Development must protect at least 65% of the site in a forest or native condition, and a 100' vegetated flowpath must be provided for discharged flows.	Infeasible	Less than 65% of site area will be left "undisturbed" due to proposed development activities.
T5.10A	Downspout Full Infiltration Systems	Field testing must indicate a native soil saturated hydraulic conductivity greater than 0.30 in/hr, and at least 1' of vertical separation must be available between the facility and confining layer(s) or groundwater. Adequate setbacks from proposed structures must also be observed.	Feasible	Preliminary geotechnical investigation suggests design infiltration rates of 0.3 in/hr onsite, pending further testing. Due to shallow groundwater constraints near the NW corner of the site, individual downspout infiltration facilities cannot be provided. Instead, roof areas will be collected and routed to one of two infiltration gallery facilities located near the southern and northeastern portions of the site.
T7.30	Bioretention	Bioretention facilities must provide a minimum horizontally projected surface area below the overflow which is at least 5% of the total surface area draining to it. Slopes through bioretention facilities must not exceed 10 percent.	N/A	N/A
T5.10B	Downspout Dispersion Systems	A minimum 25' vegetated flowpath must be provided for dispersed flows.	N/A	N/A
T5.10C	Perforated Stub-out Connections	Provide a length of perforated pipe within a gravel filled trench to accommodate infiltration, while observing setback criteria.	N/A	N/A
Other Hard Surfaces:				
T5.30	Full Dispersion	Development must protect at least 65% of the site in a forest or native condition, and a 100' vegetated flowpath must be provided for discharged flows.	Infeasible	Less than 65% of site area will be left "undisturbed" due to proposed development activities.
T5.15	Permeable Pavement	If outwash soils are present, field testing must indicate a native soil saturated hydraulic conductivity greater than 0.30 in/hr. Pavement slopes must not exceed 10 percent.	Infeasible	The native soils are not conducive to treatment and therefore basic treatment must be provided prior to infiltration. Therefore this BMP is infeasible. Stormwater runoff from the proposed roadways and sidewalks will be collected, conveyed to a mechanical treatment facility and infiltrated within one of two infiltration basins.
T5.14B	Bioretention	Bioretention facilities must provide a minimum horizontally projected surface area below the overflow which is at least 5% of the total surface area draining to it.	Infeasible	N/A
T5.12	Sheet Flow Dispersion	Provide a "transition zone" and minimum 10' vegetated flowpath to attenuate flows from driveways/hard surfaces.	Infeasible	N/A

SECTION 2.0: RISK ASSESSMENT ANALYSIS AND TEMPORARY EROSION AND SEDIMENT CONTROL DESIGN

Temporary Erosion and Sediment Control

A Stormwater Pollution Prevention Plan (SWPPP) and TESC plan will be provided as part of a forthcoming construction plan submittal. The SWPPP report is modeled under the guidelines of Volume II, Section 3.0 of the 2019 DOE Manual. Construction SWPPP Elements #1 through #12 are addressed below.

Element #1 - Mark Clearing Limits: All clearing limits will be delineated with high visibility plastic/metal or silt fencing.

Element #2 - Establish Construction Access: A single construction entrance will serve as access to the site for construction vehicles from 122nd St NE.

Element #3 - Control Flow Rates: A temporary sediment pond with associated control riser will be provided to control flow rates during construction. Sediment pond design and associated sizing calculations will be provided as part of a forthcoming construction plan submittal.

Element #4 - Install Sediment Controls: Storm drain inlet protection, silt fencing, and a temporary sediment pond will be utilized to contain sediments within the clearing limits.

Element #5 - Stabilize Soils: Any exposed soils will be stabilized with plastic covering and/or temporary and permanent seeding. Further information will be provided as part of the Grading and Erosion Control Notes on the forthcoming construction plans.

Element #6 - Protect Slopes: Slopes shall be protected with plastic covering and/or temporary and permanent seeding, as specified under Element #5.

Element #7 - Protect Drain Inlets: All storm drain inlets shall be protected throughout all stages of construction.

Element #8 - Stabilize Channels and Outlets: Temporary interceptor swales and outlets shall be stabilized with mulch or seeding, check dams, and riprap pads as necessary.

Element #9 - Control Pollutants: Pollutants shall be controlled as specified in the Pollutant Control Notes on the forthcoming construction plans.

Element #10 - Control De-Watering: Disposal options for de-watering water are as specified in the De-Watering Control Notes. Concrete handling will be used for sediment trapping and turbidity reduction.

Element #11 - Maintain BMPs: Maintenance of the BMPs is specified within the Construction Sequence and Grading and Erosion Control Notes, provided as part of a forthcoming construction plan submittal.

Element #12: Manage the Project: The Grading and Erosion Control Notes specify seasonal work limitations. Maintenance of the BMPs is specified within the Construction Sequence and Grading and Erosion Control Notes, provided as part of a forthcoming construction plan submittal.

Element #13: Protect LID BMPs: Two infiltration gallery facilities will be constructed to manage onsite stormwater in the developed condition. Excavation/compaction activities within the infiltration gallery footprints shall be conducted under the guidance of a geotechnical engineer to prevent excessive compaction/sedimentation during construction. Similarly, the proposed rock gallery volume shall be protected from sedimentation throughout construction.

SECTION 3.0: DOWNSTREAM ANALYSIS REPORT

Task 1. Study Area Definition and Maps

Snohomish County LiDAR, survey, and 2012 aerial photography were the best topographical references available for the area containing the site. The limits of the downstream analysis extend roughly 0.25 miles beyond the subject property's natural discharge location (See Figure 3.0, Downstream Analysis Map).

Task 2. Resource Review

All resources below have been reviewed for existing and potential issues near the project site:

- **Adopted Basin Plans**
No Adopted Basin Plans were located that include the project site.
- **Drainage Basin**
This site is located in the Lower West Fork Quilceda Subbasin.
- **Floodplain / Floodway (FEMA) maps**
According to FEMA floodplain mapping, the subject property is not within a floodplain. Reference the FEMA FIS study in Appendix 3 as necessary.
- **Critical Areas Map**
City of Marysville critical areas mapping does not indicate any critical areas or associated buffers on or immediately adjacent to the site.

- **Drainage Complaints**

There are no known drainage complaints within the immediate downstream flowpath of the site.

- **Road Drainage Problems**

No road drainage issues were identified.

- **Soil Survey**

According to USDA Soil Mapping, site soils consist primarily of Custer Fine Sandy Loam, a Hydrologic Group C/D soil which is primarily associated with glacial outwash deposits. USGS surficial mapping (*Distribution and description of the geologic units in the Marysville quadrangle, Washington, prepared by J.P. Minard, 1980*) is consistent with these findings, indicating Vashon recessional outwash (Marysville sand member) throughout the project site and surrounding areas. Geotechnical analysis prepared by Terra Associates, Inc. (dated August 31, 2022) indicates approximately 6 to 9 inches of organic topsoil underlain by 1.5 to 5 feet of loose to medium dense, fine to course-grained sand and gravel. Groundwater and mottling/oxidation staining was observed as shallow ad 9 to 12 inches below grade at the northwest corner of the site, and as deep as 5 feet below grade on the southern portion of the site.

Due to the presence of shallow groundwater, full infiltration of developed flows is not considered feasible across the site. However, geotechnical analysis does indicate that limited infiltration may be utilized in areas where deeper groundwater is observed near the southern and eastern portions of the site. A preliminary design infiltration rates of 0.3 in/hr is recommended for these systems, subject to further infiltration testing.

- **Wetland Inventory Maps**
No wetland areas have been identified on or immediately adjacent to the site.

- **Migrating River Studies**
Migrating River Studies are not applicable to the proposed development.

- **Section 303d List of Polluted Waters**
Washington State Department of Ecology's Water Quality Assessment for Washington does not contain any listings downstream of the project site within the typical 0.25-mile analysis distance.

- **Water Quality Problems**
No known water quality problems are present onsite or within 0.25-miles of the site.

- **Stormwater Compliance Plans**
Not applicable to the proposed project.

Task 3. Field Inspection, Upstream & Downstream Analysis (See Figure 3.0, Appendix 3)

On September 8th, 2022, a site visit was conducted to assess site conditions and verify the downstream flowpath. The following observations were verified during the visit.

Onsite Basin:

The site is currently developed with one single-family residence and two outbuildings, along with associate drive accesses. Some tree cover is present immediately surrounding the home and outbuildings, while the remainder of the parcel is maintained as lawn/landscaped area. Site slopes are generally gentle, and trend west/southwest towards an existing drainage swale which extends north-south along the western property boundary. Existing stormwater runoff flows generally westward to the existing drainage swale, which carries flow southward and discharges to the City of Marysville conveyance system within 122nd St NE, near the southwestern corner of the property. Discharged flows appear to follow a single downstream flowpath (Flowpath A), which is further characterized below.

Flowpath A:

The site lies within a single threshold discharge area and contains a single natural discharge point at its southwestern margin. In the existing condition, site runoff flows generally westward as sheet flow over gentle slopes and collects within an existing drainage swale which runs north-south along the western property boundary. Flow conveys southward within the existing swale and discharges to the existing City of Marysville stormwater conveyance system near the southwestern corner of the site, at the northern margin of 122nd St NE. The existing City conveyance system carries flow southward across 122nd St NE, where it redirects westward. Flow continues westward along the southern margin of 122nd St NE for approximately 950 LF, before discharging to the I-5 ROW near the intersection of 122nd St NE and 35th Ave NE. Flow continues southward for approximately 850 LF within the existing drainage swales along the eastern margin of I-5 before exiting the 0.25-mile boundary of analysis. All flow emanating from the site eventually discharges to Quilceda Creek, which in turn outlets to Possession Sound.

Task 4. Drainage System Description and Problem Descriptions

Based on all resources available including visual inspection of each downstream flowpath, no downstream drainage issues were identified. All flows are adequately carried into/through existing drainage structures/conveyances.

Task 5. Mitigation of Existing or Potential Drainage Problems (not applicable for Level 1 Analysis)

No evidence of existing or potential problems with upstream or downstream drainage conveyances/infrastructure was encountered. No mitigation is required for these drainage discharge routes.

Appendix 3: Resource Review

1. Figure 3.0 - Downstream Analysis Map
2. Downstream Analysis Photographs
3. FEMA Floodplain Map
4. USDA Soils Map

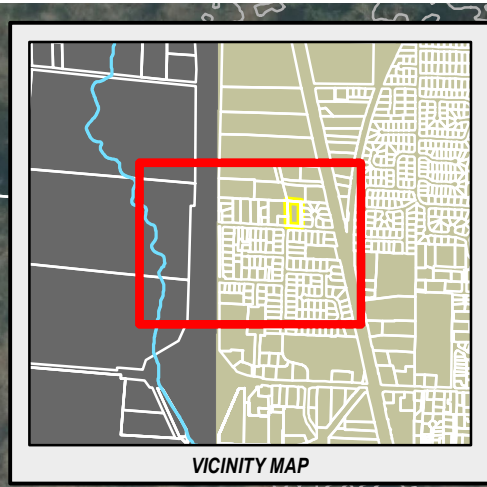

VICINITY MAP

LEGEND

- Subject Property
- Parcel Boundary
- Watercourse
- Downstream Flowpath
- Existing Drainage System
- Existing Catch Basin

Contours (LiDAR)

- 2 Foot Contour



STACK DESIGN AND CONSTRUCTION, LLC

STACK SHORT PLAT
DOWNSTREAM ANALYSIS MAP

NAD 1983 HARN
STATEPLANE WASHINGTON
NORTH FIPS 4601 FEET

REVISION:
JOB NUMBER: C22-144
DRAWING NAME: C22-144-3.0
DESIGNER: JSMITH
DRAWING BY: SWILSON
DATE: 9/9/2022
SCALE: AS SHOWN
JURISDICTION: MARYSVILLE

FIGURE:
3.0



Woodville
20210 142nd Avenue NE
Woodville, WA 98072
T: 425.306.1869 www.LDCcorp.com

Kent
1851 Central Pl S, #101
Kent, WA 98030
F: 425.482.2893

SOURCE INFORMATION

SOURCE AGENCY	DESCRIPTION
SNOHOMISH COUNTY GIS	PARCEL BOUNDARY
SNOHOMISH COUNTY GIS	CONTOURS GENERATED FROM BARE EARTH LIDAR (KING COUNTY). THIS DATA HAS A STATED VERTICAL ACCURACY OF APPROXIMATELY 1 FOOT.



Image 1: Facing northward from the southwest portion of the site near 122nd St NE. Onsite runoff generally flows west/southwestward as sheet flow over gentle slopes and collects within an existing drainage swale running north-south along the western property boundary.



Image 2: Facing southward towards 122nd St NE along the western edge of the property. Site runoff flowing westward into the swale is directed southward, where it enters the existing City of Marysville conveyance system via a 12” culvert at the southwestern corner of the property, along the northern margin of 122nd St NE.



Image 3: Flow within the existing onsite drainage swale enters a 12" culvert near the southwestern corner of the property. Flow crosses southward beneath 122nd St NE before continuing westward in the existing City of Marysville stormwater conveyance system along the southern margin of 122nd St NE.



Image 4: Facing westward on 122nd St NE near the southeast corner of the site. Stormwater runoff entering the existing City stormwater system is conveyed southward and subsequently westward along 122nd St NE, eventually discharging to the I-5 ROW near the intersection of 122nd St NE and 35th Ave NE.

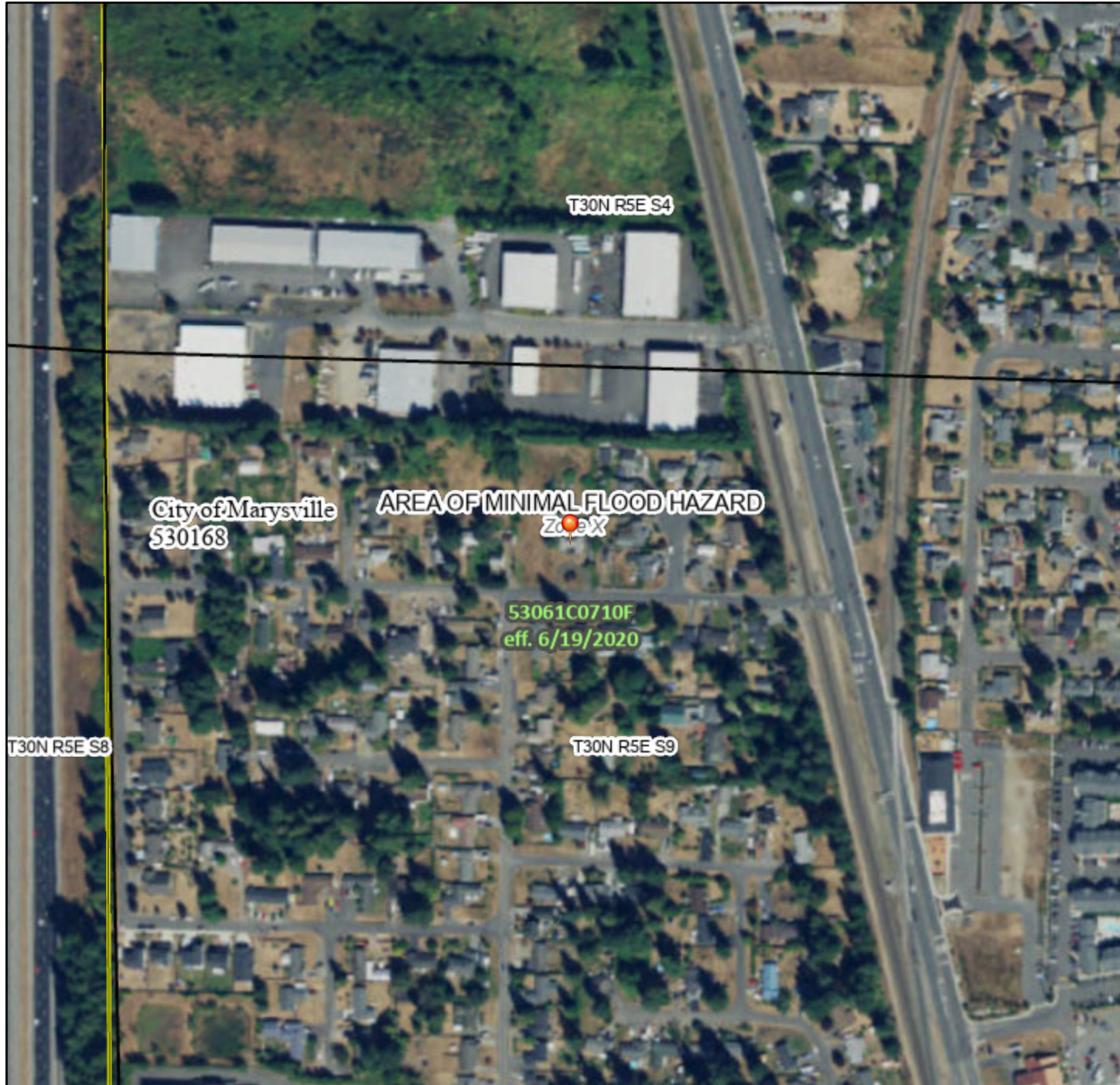

Image 5: Facing westward at the intersection of 122nd St NE and 35th Ave NE, where flow within the City conveyance system discharges to an existing drainage swale along the eastern margin of the I-5 ROW. Flow continues southward within the existing drainage swales along the eastern margin of I-5 before exiting the 0.25-mile boundary of analysis.

National Flood Hazard Layer FIRMMette



122°11'6"W 48°6'34"N



0 250 500 1,000 1,500 2,000 Feet 1:6,000

Basemap: USGS National Map: Orthoimagery: Data refreshed October, 2020

122°10'29"W 48°6'10"N

Legend

SEE FIS REPORT FOR DETAILED LEGEND AND INDEX MAP FOR FIRM PANEL LAYOUT

SPECIAL FLOOD HAZARD AREAS		Without Base Flood Elevation (BFE) <i>Zone A, V, A99</i>
		With BFE or Depth <i>Zone AE, AO, AH, VE, AR</i>
		Regulatory Floodway
OTHER AREAS OF FLOOD HAZARD		0.2% Annual Chance Flood Hazard, Areas of 1% annual chance flood with average depth less than one foot or with drainage areas of less than one square mile <i>Zone X</i>
		Future Conditions 1% Annual Chance Flood Hazard <i>Zone X</i>
		Area with Reduced Flood Risk due to Levee. See Notes. <i>Zone X</i>
		Area with Flood Risk due to Levee <i>Zone D</i>
OTHER AREAS		NO SCREEN Area of Minimal Flood Hazard <i>Zone X</i>
		Effective LOMRs
GENERAL STRUCTURES		Area of Undetermined Flood Hazard <i>Zone D</i>
		Channel, Culvert, or Storm Sewer
		Levee, Dike, or Floodwall
OTHER FEATURES		20.2 Cross Sections with 1% Annual Chance
		17.5 Water Surface Elevation
		Coastal Transect
		Base Flood Elevation Line (BFE)
		Limit of Study
MAP PANELS		Jurisdiction Boundary
		Coastal Transect Baseline
		Profile Baseline
		Hydrographic Feature
		Digital Data Available
		No Digital Data Available
		Unmapped
		The pin displayed on the map is an approximate point selected by the user and does not represent an authoritative property location.



This map complies with FEMA's standards for the use of digital flood maps if it is not void as described below. The basemap shown complies with FEMA's basemap accuracy standards

The flood hazard information is derived directly from the authoritative NFHL web services provided by FEMA. This map was exported on **9/7/2022 at 5:13 PM** and does not reflect changes or amendments subsequent to this date and time. The NFHL and effective information may change or become superseded by new data over time.

This map image is void if the one or more of the following map elements do not appear: basemap imagery, flood zone labels, legend, scale bar, map creation date, community identifiers, FIRM panel number, and FIRM effective date. Map images for unmapped and unmodernized areas cannot be used for regulatory purposes.

Custom Soil Resource Report Soil Map



Map Scale: 1:615 if printed on A portrait (8.5" x 11") sheet.

0 5 10 20 30 Meters

0 25 50 100 150 Feet

Map projection: Web Mercator Corner coordinates: WGS84 Edge tics: UTM Zone 10N WGS84

MAP LEGEND

Area of Interest (AOI)

 Area of Interest (AOI)

Soils

 Soil Map Unit Polygons

 Soil Map Unit Lines

 Soil Map Unit Points

Special Point Features

-  Blowout
-  Borrow Pit
-  Clay Spot
-  Closed Depression
-  Gravel Pit
-  Gravelly Spot
-  Landfill
-  Lava Flow
-  Marsh or swamp
-  Mine or Quarry
-  Miscellaneous Water
-  Perennial Water
-  Rock Outcrop
-  Saline Spot
-  Sandy Spot
-  Severely Eroded Spot
-  Sinkhole
-  Slide or Slip
-  Sodic Spot

-  Spoil Area
-  Stony Spot
-  Very Stony Spot
-  Wet Spot
-  Other
-  Special Line Features

Water Features

 Streams and Canals

Transportation

-  Rails
-  Interstate Highways
-  US Routes
-  Major Roads
-  Local Roads

Background

 Aerial Photography

MAP INFORMATION

The soil surveys that comprise your AOI were mapped at 1:24,000.

Warning: Soil Map may not be valid at this scale.

Enlargement of maps beyond the scale of mapping can cause misunderstanding of the detail of mapping and accuracy of soil line placement. The maps do not show the small areas of contrasting soils that could have been shown at a more detailed scale.

Please rely on the bar scale on each map sheet for map measurements.

Source of Map: Natural Resources Conservation Service
 Web Soil Survey URL:
 Coordinate System: Web Mercator (EPSG:3857)

Maps from the Web Soil Survey are based on the Web Mercator projection, which preserves direction and shape but distorts distance and area. A projection that preserves area, such as the Albers equal-area conic projection, should be used if more accurate calculations of distance or area are required.

This product is generated from the USDA-NRCS certified data as of the version date(s) listed below.

Soil Survey Area: Snohomish County Area, Washington
 Survey Area Data: Version 23, Aug 31, 2021

Soil map units are labeled (as space allows) for map scales 1:50,000 or larger.

Date(s) aerial images were photographed: Aug 16, 2020—Aug 19, 2020

The orthophoto or other base map on which the soil lines were compiled and digitized probably differs from the background imagery displayed on these maps. As a result, some minor shifting of map unit boundaries may be evident.

Map Unit Legend

Map Unit Symbol	Map Unit Name	Acres in AOI	Percent of AOI
13	Custer fine sandy loam	1.4	100.0%
Totals for Area of Interest		1.4	100.0%

Map Unit Descriptions

The map units delineated on the detailed soil maps in a soil survey represent the soils or miscellaneous areas in the survey area. The map unit descriptions, along with the maps, can be used to determine the composition and properties of a unit.

A map unit delineation on a soil map represents an area dominated by one or more major kinds of soil or miscellaneous areas. A map unit is identified and named according to the taxonomic classification of the dominant soils. Within a taxonomic class there are precisely defined limits for the properties of the soils. On the landscape, however, the soils are natural phenomena, and they have the characteristic variability of all natural phenomena. Thus, the range of some observed properties may extend beyond the limits defined for a taxonomic class. Areas of soils of a single taxonomic class rarely, if ever, can be mapped without including areas of other taxonomic classes. Consequently, every map unit is made up of the soils or miscellaneous areas for which it is named and some minor components that belong to taxonomic classes other than those of the major soils.

Most minor soils have properties similar to those of the dominant soil or soils in the map unit, and thus they do not affect use and management. These are called noncontrasting, or similar, components. They may or may not be mentioned in a particular map unit description. Other minor components, however, have properties and behavioral characteristics divergent enough to affect use or to require different management. These are called contrasting, or dissimilar, components. They generally are in small areas and could not be mapped separately because of the scale used. Some small areas of strongly contrasting soils or miscellaneous areas are identified by a special symbol on the maps. If included in the database for a given area, the contrasting minor components are identified in the map unit descriptions along with some characteristics of each. A few areas of minor components may not have been observed, and consequently they are not mentioned in the descriptions, especially where the pattern was so complex that it was impractical to make enough observations to identify all the soils and miscellaneous areas on the landscape.

The presence of minor components in a map unit in no way diminishes the usefulness or accuracy of the data. The objective of mapping is not to delineate pure taxonomic classes but rather to separate the landscape into landforms or landform segments that have similar use and management requirements. The delineation of such segments on the map provides sufficient information for the development of resource plans. If intensive use of small areas is planned, however, onsite investigation is needed to define and locate the soils and miscellaneous areas.

Custom Soil Resource Report

An identifying symbol precedes the map unit name in the map unit descriptions. Each description includes general facts about the unit and gives important soil properties and qualities.

Soils that have profiles that are almost alike make up a *soil series*. Except for differences in texture of the surface layer, all the soils of a series have major horizons that are similar in composition, thickness, and arrangement.

Soils of one series can differ in texture of the surface layer, slope, stoniness, salinity, degree of erosion, and other characteristics that affect their use. On the basis of such differences, a soil series is divided into *soil phases*. Most of the areas shown on the detailed soil maps are phases of soil series. The name of a soil phase commonly indicates a feature that affects use or management. For example, Alpha silt loam, 0 to 2 percent slopes, is a phase of the Alpha series.

Some map units are made up of two or more major soils or miscellaneous areas. These map units are complexes, associations, or undifferentiated groups.

A *complex* consists of two or more soils or miscellaneous areas in such an intricate pattern or in such small areas that they cannot be shown separately on the maps. The pattern and proportion of the soils or miscellaneous areas are somewhat similar in all areas. Alpha-Beta complex, 0 to 6 percent slopes, is an example.

An *association* is made up of two or more geographically associated soils or miscellaneous areas that are shown as one unit on the maps. Because of present or anticipated uses of the map units in the survey area, it was not considered practical or necessary to map the soils or miscellaneous areas separately. The pattern and relative proportion of the soils or miscellaneous areas are somewhat similar. Alpha-Beta association, 0 to 2 percent slopes, is an example.

An *undifferentiated group* is made up of two or more soils or miscellaneous areas that could be mapped individually but are mapped as one unit because similar interpretations can be made for use and management. The pattern and proportion of the soils or miscellaneous areas in a mapped area are not uniform. An area can be made up of only one of the major soils or miscellaneous areas, or it can be made up of all of them. Alpha and Beta soils, 0 to 2 percent slopes, is an example.

Some surveys include *miscellaneous areas*. Such areas have little or no soil material and support little or no vegetation. Rock outcrop is an example.

Snohomish County Area, Washington

13—Custer fine sandy loam

Map Unit Setting

National map unit symbol: 2hy0

Elevation: 0 to 150 feet

Mean annual precipitation: 32 to 50 inches

Mean annual air temperature: 48 to 50 degrees F

Frost-free period: 150 to 200 days

Farmland classification: Prime farmland if irrigated and drained

Map Unit Composition

Custer, undrained, and similar soils: 85 percent

Minor components: 15 percent

Estimates are based on observations, descriptions, and transects of the mapunit.

Description of Custer, Undrained

Setting

Landform: Outwash plains

Parent material: Glacial outwash

Typical profile

H1 - 0 to 9 inches: fine sandy loam

H2 - 9 to 35 inches: sand

H3 - 35 to 60 inches: sand

Properties and qualities

Slope: 0 to 2 percent

Depth to restrictive feature: 20 to 40 inches to strongly contrasting textural stratification

Drainage class: Poorly drained

Capacity of the most limiting layer to transmit water (Ksat): Moderately high (0.20 to 0.57 in/hr)

Depth to water table: About 0 to 12 inches

Frequency of flooding: None

Frequency of ponding: None

Maximum salinity: Nonsaline to very slightly saline (0.0 to 2.0 mmhos/cm)

Available water supply, 0 to 60 inches: Low (about 3.1 inches)

Interpretive groups

Land capability classification (irrigated): None specified

Land capability classification (nonirrigated): 5w

Hydrologic Soil Group: C/D

Ecological site: F002XA007WA - Puget Lowlands Wet Forest

Forage suitability group: Wet Soils (G002XN102WA)

Other vegetative classification: Wet Soils (G002XN102WA)

Hydric soil rating: Yes

Minor Components

Norma, undrained

Percent of map unit: 5 percent

Landform: Depressions

Other vegetative classification: Wet Soils (G002XN102WA)

Custom Soil Resource Report

Hydric soil rating: Yes

Indianola

Percent of map unit: 5 percent

Hydric soil rating: No

Custer, drained

Percent of map unit: 5 percent

Landform: Depressions

Other vegetative classification: Soils with Few Limitations (G002XN502WA)

Hydric soil rating: Yes

SECTION 4.0: DETENTION AND WATER QUALITY FACILITY ANALYSIS AND DESIGN

4.1 Predeveloped Hydrology

The predeveloped and developed conditions were modeled in WWHM2012 for the purpose of infiltration sizing and peak flow comparison. Based on the site location, the WWHM model used the Everett Gage and a Precipitation Scale factor of 1.2.

As the existing land coverage within the project boundaries does not total 35% or greater of impervious cover, the project is considered new development. The predeveloped condition (forested) is applied to all the area of the Onsite Basin, while approximately 0.025 acres of impervious area is assigned to the Frontage Basin to reflect the existing pavement which remains tributary to the site in the developed condition.

For visual representation of the following basins, see Figure 4.0, “Predeveloped Hydrology Map” located in Appendix 4. For an additional tabulated summary of the following areas, see the Predeveloped Spreadsheet. A tabulated summary of the predeveloped basins as was modeled in WWHM2012 is as follows:

Table 4-1 - Predeveloped Conditions Areas

Predeveloped Conditions as Modeled in WWHM2012		
Basin	Land Cover	Area
Onsite Basin	C, Forest, Flat	1.240 AC
Frontage Basin	Pavement, Flat	0.025 AC
	C, Forest, Flat	0.020 AC
Total		1.285 AC

4.2 Developed Hydrology

The Stack Short Plat project proposes the development of 5 new single-family lots, along with associated accesses and utilities on the 1.31-acre site. Additionally, the project proposes frontage improvements along the northern margin of 122nd St NE, to include minor pavement widening and construction of new sidewalk. In total, the project will disturb 1.285 acres and create 0.69 acres of new impervious surfaces.

In compliance with the requirements within the City of Marysville EDDS and the 2019 DOE Manual, all runoff from onsite developed/disturbed surfaces will be collected, treated, and infiltrated/released to existing/historic flow paths within allowable flow rates per WWHM2012. The onsite drainage system will consist of catch basins, stormwater conveyance pipe, and two infiltration galleries (Infiltration Gallery #1 and Infiltration Gallery #2), located at the southern and northeastern portions of the site, respectively. Detailed breakdowns of developed ground coverages as modeled in WWHM are included below. For visual representation of the following developed basins, see Figure 5.0, “Developed Hydrology Map” in Appendix 4.

Onsite Basin 1 (To Infiltration Gallery #1):

Onsite Basin 1 is 1.18 acres in the developed condition, consisting of all onsite area to be conveyed to Infiltration Gallery #1. This basin contains all onsite area to-be-developed, with exception of roof area associated with Lot 5 which will be infiltrated separately. For a visual representation of Onsite Basin 1, see Figure 5.0, “Developed Hydrology Map” in Appendix 4. In the developed condition, Onsite Basin 1 has been modeled using WWHM2012 with the following areas and ground cover designations:

Table 4-2.1 - Developed Conditions Areas: Onsite Basin 1

Onsite Basin 1	
Land Cover	Area
Roof, Flat	0.24 AC
Pavement, Flat	0.19 AC
Driveways, Flat	0.03 AC
Sidewalk, Flat	0.06 AC
Pasture, Flat	0.66 AC
Total	1.18 AC

Onsite Basin 2 (To Infiltration Gallery #2):

Onsite Basin 2 is 0.06 acres in the developed condition, consisting of all onsite area to be conveyed to Infiltration Gallery #2. This basin consists solely of roof area associated with Lot 5. For a visual representation of Onsite Basin 2, see Figure 5.0, “Developed Hydrology Map” in Appendix 4. In the developed condition, Onsite Basin 2 has been modeled using WWHM2012 with the following areas and ground cover designations:

Table 4-2.2 - Developed Conditions Areas: Onsite Basin 2

Onsite Basin 2	
Land Cover	Area
Roof, Flat	0.06 AC
Total	0.06 AC

Frontage Basin:

The Frontage Basin is 0.045 acres in the developed condition and consists of a combination of existing and proposed ROW surfaces. Due to topographic constraints and limited infiltration capabilities onsite, this area will bypass Infiltration Gallery #1 and discharge to the existing City stormwater conveyance system within the 122nd St NE ROW. For a visual representation of Onsite Basin 2, see Figure 5.0, “Developed Hydrology Map” in Appendix 4. In the developed condition, The Frontage Basin was modeled using WWHM2012 with the following areas and ground cover designations:

Table 4-2.2 - Developed Conditions Areas: Frontage Basin (87th Ave NE)

Frontage Basin (87 th Ave NE)	
Land Cover	Area
Roads, Flat	0.020 AC
Sidewalks, Flat	0.020 AC
C, Pasture, Flat	0.005 AC
Total	0.045 AC

4.2 Water Quality Treatment

Water Quality Treatment for Pollution Generating Impervious Surface (PGIS) flows associated with Onsite Basin 1 is accomplished through a StormFilter Manhole cartridge filtration facility located upstream of Infiltration Gallery 1. As Onsite Basin 2 contains no PGIS areas and those associated with the Frontage Basin (0.02 AC) fall below the 5,000 sf (0.11 AC) threshold for water quality treatment, no additional measures are proposed. The following is a summary of relevant sizing criteria used to size the StormFilter facility:

72" StormFilter Manhole

WQDFR	0.095 cfs (WWHM2012)
Tributary Impervious Area	0.52 AC
Tributary PGIS	0.22 AC
Specific Flow Rate	8.35 gpm/cartridge
Number of Cartridges	6
Treatment Flow Capacity	0.112 cfs
Cartridge Height	Low Drop
Internal Drop	1.8'

4.3 Infiltration Facilities

The project proposes two infiltration facilities, referred to as Infiltration Gallery #1 and Infiltration Gallery #2, which will serve as the primary means of stormwater management for Onsite Basin 1 and 2, respectively. The proposed infiltration facilities will capture and infiltrate onsite stormwater runoff to the extent feasible, while peak flows in excess of design infiltration capacity will discharge to the existing City of Marysville conveyance system through provided overflow structures. Summaries of Infiltration Galleries #1 and #2, as designed using WWHM2012, are offered on the following pages. Detailed WWHM sizing documentation is provided in Appendix 4.

INFILTRATION GALLERY #1:

Infiltration Gallery #1 Facility Summary

<i>Contributing Basin:</i>	<i>Onsite Basin 1</i>
<i>Modeled Area:</i>	<i>4,083 SF</i>
<i>Provided Area:</i>	<i>4,085 SF</i>
<i>Volume Modeled:</i>	<i>14,291 CF</i>
<i>Volume Provided:</i>	<i>14,298 CF</i>
<i>Reservoir Porosity:</i>	<i>35%</i>
<i>Reservoir Depth:</i>	<i>3.5'</i>
<i>Bottom of Gallery El:</i>	<i>73.0</i>
<i>Riser Height:</i>	<i>3.25'</i>
<i>Overflow El:</i>	<i>76.25</i>
<i>Design Infiltration Rate:</i>	<i>0.3 in/hr</i>
<i>Percent Infiltrated:</i>	<i>99.42%</i>
<i>100-yr Peak Overflow:</i>	<i>0.227 cfs (WWHM 1000-Series)</i>

Table 4.4.1 - Infiltration Gallery #1 Peak Flow Rates by Storm Event

Storm Event	Predeveloped Rate (cfs)	Unmitigated Rate (cfs)	Discharge Rate (cfs)
2-Year	0.039	0.298	0.034
10-Year	0.077	0.507	0.085
50-Year	0.120	0.745	0.172
100-Year	0.141	0.863	0.227

INFILTRATION GALLERY #2:

Infiltration Gallery #2 Facility Summary

<i>Contributing Basin:</i>	<i>Onsite Basin 2</i>
<i>Modeled Area:</i>	<i>630 SF</i>
<i>Provided Area:</i>	<i>630 SF</i>
<i>Volume Modeled:</i>	<i>1,575 CF</i>
<i>Volume Provided:</i>	<i>1,575 CF</i>
<i>Reservoir Porosity:</i>	<i>35%</i>
<i>Reservoir Depth:</i>	<i>2.5'</i>
<i>Bottom of Gallery El:</i>	<i>75.0</i>
<i>Riser Height:</i>	<i>2.4'</i>
<i>Overflow El:</i>	<i>77.4</i>
<i>Design Infiltration Rate:</i>	<i>0.3 in/hr</i>
<i>Percent Infiltrated:</i>	<i>99.91%</i>
<i>100-yr Peak Overflow:</i>	<i>0.227 cfs (WWHM 1000-Series)</i>

Table 4.4.2 - Infiltration Gallery #2 Peak Flow Rates by Storm Event

Storm Event	Predeveloped Rate (cfs)	Unmitigated Rate (cfs)	Discharge Rate (cfs)
2-Year	0.002	0.032	0.005
10-Year	0.004	0.051	0.007
50-Year	0.006	0.071	0.010
100-Year	0.007	0.081	0.012

4.4 Peak Flow Comparison

In accordance with Minimum Requirement #5, the project proposes to mitigate developed flows to the extent feasible given observed groundwater constraints, using two separate infiltration gallery facilities. As site constraints limit available infiltration facility footprints, Infiltration Galleries 1 and 2 lack capacity to fully infiltrate developed condition stormwater runoff as detailed in Section 4.3. To assess applicability of additional flow control requirements, a peak flow analysis was performed for the 100-year, 24-hour design storm to assess whether bypassed/discharged flows associated with Onsite Basins 1-2 and the Frontage Basin exceed the 0.15 cfs threshold for flow control per the 2019 DOE Manual.

Predeveloped condition peak flow rates were calculated for the Onsite and Frontage Basins using WWHM2012. Developed condition peak flow rates for the Frontage Basin were calculated directly using WWHM2012. This value, along with peak discharge rates associated with sizing calculations performed for Infiltration Galleries 1 & 2, were combined to obtain the total developed condition peak flow. Ultimately, 100-year developed/unmitigated peak outflows (0.294 cfs) represent a 0.120 cfs increase relative to the predeveloped condition (0.174 cfs). As such, additional flow control measures beyond proposed infiltration activities are not required.

A summary of peak flow calculations as described in this section is provided below. Detailed WWHM documentation is provided in Appendix 4.

Peak Flow Comparison (Onsite & Frontage Basins)

<i>100-year Predeveloped Peak Flow (Onsite & Frontage):</i>	<i>0.174 cfs</i>
<i>100-year Developed Peak Outflow (Gallery 1):</i>	<i>0.227 cfs</i>
<i>100-year Developed Peak Outflow (Gallery 2):</i>	<i>0.012 cfs</i>
<i>100-year Developed Peak Flow (Frontage Basin):</i>	<i>0.055 cfs</i>
<i>100-year Predeveloped Peak (Combined):</i>	<i>0.294 cfs</i>
<i>Peak Flow Increase (Developed - Predeveloped):</i>	<i>0.120 cfs</i>

Appendix 4: Site Hydrology, Detention Analysis and Water Quality Facility Analysis

1. Predeveloped Basin Areas Spreadsheet
2. Figure 4.0 - Predeveloped Hydrology
3. Developed Basin Areas Spreadsheet
4. Figure 5.0 - Developed Hydrology
5. Contech StormFilter Detail
6. Infiltration Gallery 1 - WWHM Output
7. Infiltration Gallery 2 - WWHM Output
8. Peak Flow Analysis - WWHM Output

Predeveloped Areas Spreadsheet	LDC, Inc.	
	20210 142nd Ave NE Woodinville, WA 98072	Tel: (425) 806-1869 Fax: (425) 482-2893

Project Name: Stack Short Plat Project No.: C22-144
Description: Predeveloped Basin(s) Date: 9/9/2022
Calc. By: SJW

Predeveloped Basins

Modeled Basins	Area (Acres)	Existing Impervious (%)	Impervious (Acres)	Lawn (Acres)	Forested (Acres)
Onsite Basin	1.240	0.00%	0.000	0.000	1.240
Frontage Basin	0.045	0.00%	0.025	0.000	0.020
Total Modeled Area	1.285	1.95%	0.025	0.000	1.260

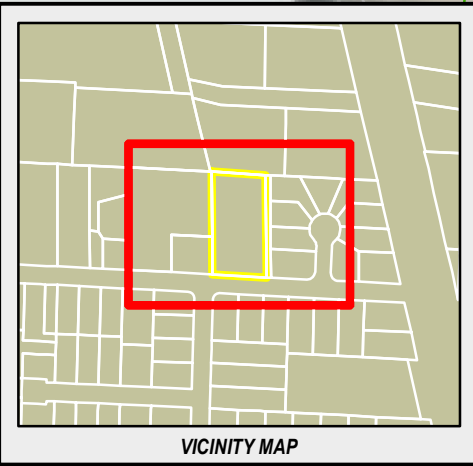

VICINITY MAP

PREDEVELOPED BASIN AREAS	
ONSITE BASIN	
Forested	1.24 AC
TOTAL	1.24 AC
ONSITE BASIN B	
Impervious	0.025 AC
Forested	0.020 AC
TOTAL	0.045 AC
UNDISTURBED (NOT MODELED)	
Forested	0.07 AC
TOTAL	0.07 AC

UNDISTURBED
0.07 AC

ONSITE BASIN
1.24 AC

FRONTAGE BASIN
0.045 AC

LEGEND

- Subject Property
- Parcel Boundary
- Watercourse
- Existing Drainage System
- Existing Catch Basin

Contours (LiDAR)

- 2 Foot Contour

4.0 Predeveloped Hydro.mxd | MOD: 9/9/2022 | swilson

STACK DESIGN AND CONSTRUCTION, LLC

STACK SHORT PLAT

PREDEVELOPED HYDROLOGY MAP

NAD 1983 HARN
STATEPLANE WASHINGTON
NORTH FIPS 4601 FEET

REVISION:
JOB NUMBER: C22-144
DRAWING NAME: C22-144-4.0
DESIGNER: JSMITH
DRAWING BY: SWILSON
DATE: 9/9/2022
SCALE: AS SHOWN
JURISDICTION: MARYSVILLE

FIGURE:
4.0

LDC

Woodinville
20210 142nd Avenue NE
Woodinville, WA 98072
T: 425.386.1869

Kent
1851 Central Pl S, #101
Kent, WA 98030
www.LDCcorp.com
F: 425.482.2893

SOURCE INFORMATION

SOURCE AGENCY	DESCRIPTION
SNOHOMISH COUNTY GIS	PARCEL BOUNDARY
SNOHOMISH COUNTY GIS	CONTOURS GENERATED FROM BARE EARTH LIDAR (KING COUNTY). THIS DATA HAS A STATED VERTICAL ACCURACY OF APPROXIMATELY 1 FOOT.

Developed Areas Spreadsheet	LDC, Inc.	
	20210 142nd Ave NE Woodinville, WA 98072	Tel: (425) 806-1869 Fax: (425) 482-2893

Project Name: Stack Short Plat
Description: Developed Basin(s)

Project No.: C22-144
Date: 9/9/2022
Calc. By: SJW

Developed Basins

Onsite Basin 1 (To Inf Gallery 1)							
	Area (Acres)	Impervious (%)	Impervious (Acres)	Pasture (Acres)	Forested (Acres)	PGIS (Acres)	
Onsite	1.180	44%	0.520	0.660	0.000	0.220	
Pavement	0.190	100.0%	0.190	0.000	0.000	0.190	
Roofs	0.240	100.0%	0.240	0.000	0.000	0.000	
Driveways	0.030	100.0%	0.030	0.000	0.000	0.030	
Sidewalks	0.060	100.0%	0.060	0.000	0.000	0.000	
Pasture	0.660	0.0%	0.000	0.660	0.000	0.000	
Onsite Basin 2 (To Inf Gallery 2)							
Onsite	0.060	100%	0.060	0.000	0.000	0.000	
Roofs	0.060	100.0%	0.060	0.000	0.000	0.000	
Frontage Basin (Bypass)							
122nd St NE	0.045	89%	0.040	0.005	0.000	0.020	
Pavement	0.020	100.0%	0.020	0.000	0.000	0.020	
Sidewalk	0.020	100.0%	0.020	0.000	0.000	0.000	
Pasture	0.005	0.0%	0.000	0.005	0.000	0.000	
Modeled Total	1.285	48%	0.620	0.665	0.000	0.240	
Onsite Total	1.180	44%	0.520	0.660	0.000	0.220	
Frontage Total	0.045	89%	0.040	0.005	0.000	0.020	
Total (To Infiltration Gallery 1)	1.180	44%	0.520	0.660	0.000	0.220	
Total (To Infiltration Gallery 2)	0.060	100%	0.060	0.000	0.000	0.000	
Total (Bypassed)	0.045	89%	0.040	0.005	0.000	0.020	

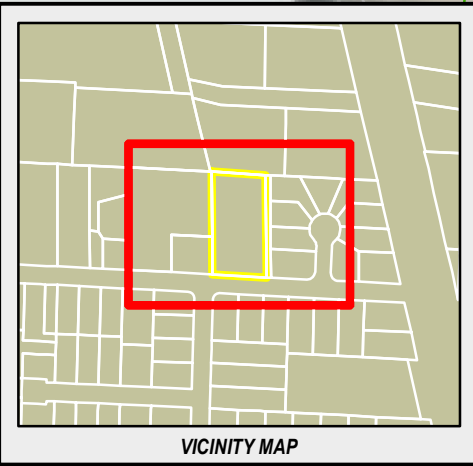

VICINITY MAP

UNDISTURBED
0.07 AC

ONSITE BASIN 2
0.06 AC

ONSITE BASIN 1
1.18 AC

INFILTRATION
GALLERY 1

INFILTRATION
GALLERY 2

FRONTAGE BASIN
0.045 AC

DEVELOPED BASIN AREAS	
ONSITE BASIN 1 (TO GALLERY 1)	
Pavement	0.19 AC
Roofs	0.24 AC
Driveways	0.03 AC
Sidewalks	0.06 AC
Pasture	0.66 AC
TOTAL	1.18 AC
ONSITE BASIN 2 (TO GALLERY 2)	
Roofs	0.06 AC
TOTAL	0.06 AC
FRONTAGE BASIN	
Pavement	0.020 AC
Sidewalks	0.020 AC
Pasture	0.005 AC
TOTAL	0.045 AC
UNDISTURBED (NOT MODELED)	
Forested	0.07 AC
TOTAL	0.07 AC

LEGEND

- Subject Property
- Parcel Boundary
- Watercourse
- Existing Drainage System
- Existing Catch Basin
- Proposed Drainage System
- Proposed Catch Basin

Contours (LiDAR)

- 2 Foot Contour

SOURCE INFORMATION

SOURCE AGENCY	DESCRIPTION
SNOHOMISH COUNTY GIS	PARCEL BOUNDARY
SNOHOMISH COUNTY GIS	CONTOURS GENERATED FROM BARE EARTH LIDAR (KING COUNTY). THIS DATA HAS A STATED VERTICAL ACCURACY OF APPROXIMATELY 1 FOOT.

LDC

Surveying
Engineering
Planning

Kent
1851 Central Pl S, #101
Kent, WA 98030
www.LDCcorp.com
F: 425-482-2893

STACK DESIGN AND CONSTRUCTION, LLC

STACK SHORT PLAT

DEVELOPED HYDROLOGY MAP

NAD 1983 HARN
STATEPLANE WASHINGTON
NORTH FIPS 4601 FEET

REVISION:

JOB NUMBER: C22-144
DRAWING NAME: C22-144-5.0
DESIGNER: JSMITH
DRAWING BY: SWILSON
DATE: 9/9/2022
SCALE: AS SHOWN
JURISDICTION: MARYSVILLE

FIGURE:

5.0

5.0 Developed Hydro.mxd | MOD: 9/9/2022 | swilson

STORMFILTER DESIGN NOTES

STORMFILTER TREATMENT CAPACITY IS A FUNCTION OF THE CARTRIDGE SELECTION AND THE NUMBER OF CARTRIDGES. THE STANDARD MANHOLE STYLE IS SHOWN WITH THE MAXIMUM NUMBER OF CARTRIDGES (7). VOLUME SYSTEM IS ALSO AVAILABLE WITH MAXIMUM 7 CARTRIDGES. Ø6'-0" [1829 mm] MANHOLE STORMFILTER PEAK HYDRAULIC CAPACITY IS 1.5 CFS [42.5 L/s]. IF THE SITE CONDITIONS EXCEED 1.5 CFS [42.5 L/s] AN UPSTREAM BYPASS STRUCTURE IS REQUIRED.

CARTRIDGE SELECTION

CARTRIDGE HEIGHT	27" [686 mm]			18" [458 mm]			LOW DROP		
RECOMMENDED HYDRAULIC DROP (H)	3.05' [930 mm]			2.3' [700 mm]			1.8' [550 mm]		
SPECIFIC FLOW RATE (gpm/sf) [L/s/m ²]	2 [1.30]	1.67* [1.08]	1 [0.65]	2 [1.30]	1.67* [1.08]	1 [0.65]	2 [1.30]	1.67* [1.08]	1 [0.65]
CARTRIDGE FLOW RATE (gpm) [L/s]	22.5 [1.42]	18.79 [1.19]	11.25 [0.71]	15 [0.95]	12.53 [0.79]	7.5 [0.44]	10 [0.63]	8.35 [0.54]	5 [0.32]

* 1.67 gpm/sf [1.08 L/s/m²] SPECIFIC FLOW RATE IS APPROVED WITH PHOSPHOSORB® (PSORB) MEDIA ONLY

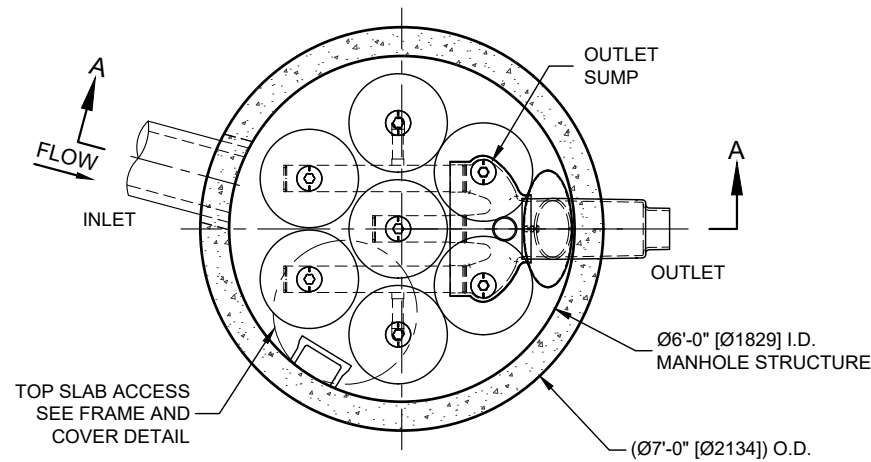

PLAN VIEW
STANDARD OUTLET RISER
FLOWKIT: 42A

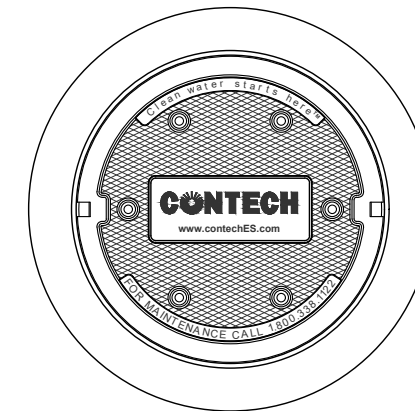

FRAME AND COVER
(DIAMETER VARIES)
N.T.S.

SITE SPECIFIC DATA REQUIREMENTS

STRUCTURE ID	*		
WATER QUALITY FLOW RATE (cfs) [L/s]	*		
PEAK FLOW RATE (cfs) [L/s]	*		
RETURN PERIOD OF PEAK FLOW (yrs)	*		
CARTRIDGE HEIGHT (SEE TABLE ABOVE)	*		
NUMBER OF CARTRIDGES REQUIRED	*		
CARTRIDGE FLOW RATE	*		
MEDIA TYPE (PERLITE, ZPG, PSORB)	*		
PIPE DATA:			
	I.E.	MATERIAL	DIAMETER
INLET PIPE #1	*	*	*
INLET PIPE #2	*	*	*
OUTLET PIPE	*	*	*
RIM ELEVATION			
*			
ANTI-FLOTATION BALLAST		WIDTH	HEIGHT
		*	*
NOTES/SPECIAL REQUIREMENTS:			
* PER ENGINEER OF RECORD			

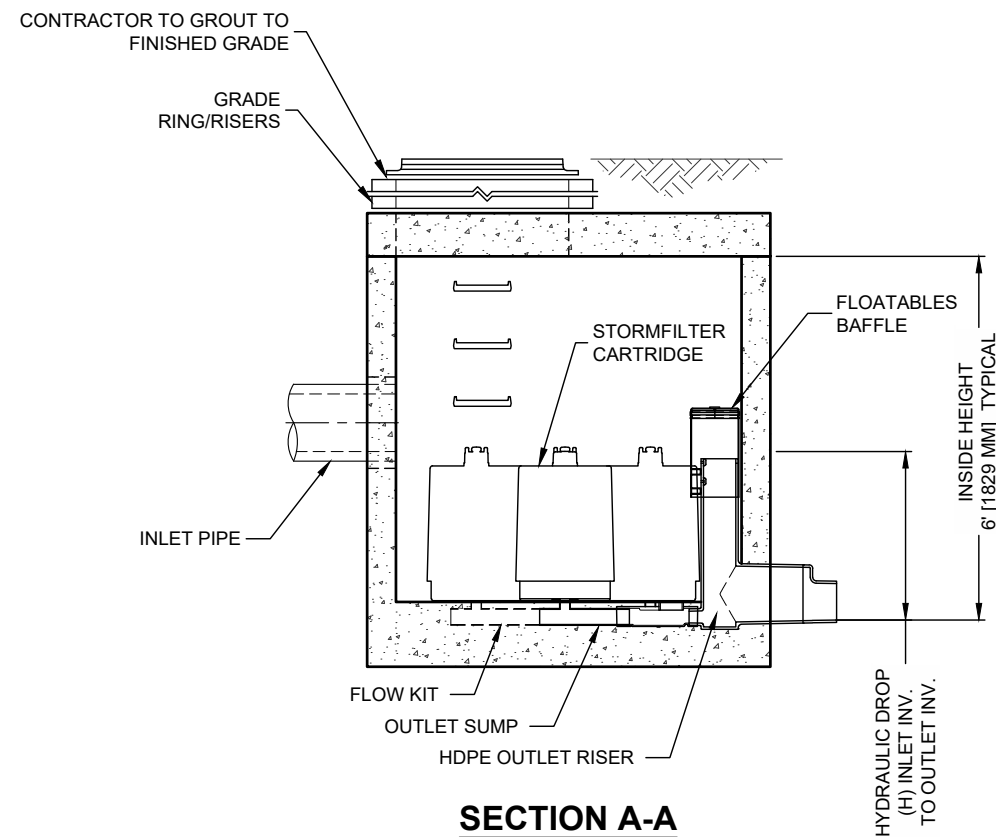

SECTION A-A

GENERAL NOTES

- CONTECH TO PROVIDE ALL MATERIALS UNLESS NOTED OTHERWISE.
- DIMENSIONS MARKED WITH () ARE REFERENCE DIMENSIONS. ACTUAL DIMENSIONS MAY VARY.
- FOR SITE SPECIFIC DRAWINGS WITH DETAILED VAULT DIMENSIONS AND WEIGHTS, PLEASE CONTACT YOUR CONTECH ENGINEERED SOLUTIONS LLC REPRESENTATIVE. www.contechES.com
- STORMFILTER WATER QUALITY STRUCTURE SHALL BE IN ACCORDANCE WITH ALL DESIGN DATA AND INFORMATION CONTAINED IN THIS DRAWING.
- STRUCTURE SHALL MEET AASHTO HS-20 LOAD RATING, ASSUMING EARTH COVER OF 0' - 5' [1524 mm] AND GROUNDWATER ELEVATION AT, OR BELOW, THE OUTLET PIPE INVERT ELEVATION. ENGINEER OF RECORD TO CONFIRM ACTUAL GROUNDWATER ELEVATION. CASTINGS SHALL MEET AASHTO M306 AND BE CAST WITH THE CONTECH LOGO.
- FILTER CARTRIDGES SHALL BE MEDIA-FILLED, PASSIVE, SIPHON ACTUATED, RADIAL FLOW, AND SELF CLEANING. RADIAL MEDIA DEPTH SHALL BE 7-INCHES [178 mm]. FILTER MEDIA CONTACT TIME SHALL BE AT LEAST 38 SECONDS.
- SPECIFIC FLOW RATE IS EQUAL TO THE FILTER TREATMENT CAPACITY (gpm) [L/s] DIVIDED BY THE FILTER CONTACT SURFACE AREA (sq ft)[m²].
- STORMFILTER STRUCTURE SHALL BE PRECAST CONCRETE CONFORMING TO ASTM C-478 AND AASHTO LOAD FACTOR DESIGN METHOD.

INSTALLATION NOTES

- ANY SUB-BASE, BACKFILL DEPTH, AND/OR ANTI-FLOTATION PROVISIONS ARE SITE-SPECIFIC DESIGN CONSIDERATIONS AND SHALL BE SPECIFIED BY ENGINEER OF RECORD.
- CONTRACTOR TO PROVIDE EQUIPMENT WITH SUFFICIENT LIFTING AND REACH CAPACITY TO LIFT AND SET THE STORMFILTER STRUCTURE.
- CONTRACTOR TO INSTALL JOINT SEALANT BETWEEN ALL STRUCTURE SECTIONS AND ASSEMBLE STRUCTURE.
- CONTRACTOR TO PROVIDE, INSTALL, AND GROUT INLET PIPE(S).
- CONTRACTOR TO PROVIDE AND INSTALL CONNECTOR TO THE OUTLET RISER STUB. STORMFILTER EQUIPPED WITH A DUAL DIAMETER HDPE OUTLET STUB AND SAND COLLAR. IF OUTLET PIPE IS LARGER THAN 8 INCHES [200 mm], CONTRACTOR TO REMOVE THE 8 INCH [200 mm] OUTLET STUB AT MOLDED-IN CUT LINE. COUPLING BY FERNCO OR EQUAL AND PROVIDED BY CONTRACTOR.
- CONTRACTOR TO TAKE APPROPRIATE MEASURES TO PROTECT CARTRIDGES FROM CONSTRUCTION-RELATED EROSION RUNOFF.



THIS PRODUCT MAY BE PROTECTED BY ONE OR MORE OF THE FOLLOWING
U.S. PATENTS: 5,322,629; 5,524,576; 5,707,527; 5,985,157; 6,027,639; 6,649,048;
RELATED FOREIGN PATENTS, OR OTHER PATENTS PENDING.

CONTECH
ENGINEERED SOLUTIONS LLC

www.contechES.com

9025 Centre Pointe Dr., Suite 400, West Chester, OH 45069

800-338-1122 513-645-7000 513-645-7993 FAX

SFMH72
STORMFILTER
STANDARD DETAIL

WWHM2012

PROJECT REPORT

INFILTRATION GALLERY 1

General Model Information

Project Name: 20220822 Onsite Infiltration
Site Name:
Site Address:
City:
Report Date: 9/9/2022
Gage: Everett
Data Start: 1948/10/01
Data End: 2009/09/30
Timestep: 15 Minute
Precip Scale: 1.200
Version Date: 2021/08/18
Version: 4.2.18

POC Thresholds

Low Flow Threshold for POC1: 50 Percent of the 2 Year
High Flow Threshold for POC1: 50 Year

DRAFT

Landuse Basin Data
Predeveloped Land Use

Onsite Basin 1

Bypass:	No
GroundWater:	No
Pervious Land Use C, Forest, Flat	acre 1.18
Pervious Total	1.18
Impervious Land Use	acre
Impervious Total	0
Basin Total	1.18

Element Flows To:
Surface Interflow Groundwater

DRAFT

Mitigated Land Use

Onsite Basin 1

Bypass: No

GroundWater: No

Pervious Land Use acre
C, Pasture, Flat 0.66

Pervious Total 0.66

Impervious Land Use acre
ROADS FLAT 0.19
ROOF TOPS FLAT 0.24
DRIVEWAYS FLAT 0.03
SIDEWALKS FLAT 0.06

Impervious Total 0.52

Basin Total 1.18

Element Flows To:

Surface	Interflow	Groundwater
Infiltration Gallery #1	Infiltration Gallery #1	

DRAFT

Routing Elements
Predeveloped Routing

DRAFT

Mitigated Routing

Infiltration Gallery #1

Bottom Length:	63.90 ft.
Bottom Width:	63.90 ft.
Trench bottom slope 1:	0 To 1
Trench Left side slope 0:	0 To 1
Trench right side slope 2:	0 To 1
Material thickness of first layer:	3.5
Pour Space of material for first layer:	0.35
Material thickness of second layer:	0
Pour Space of material for second layer:	0
Material thickness of third layer:	0
Pour Space of material for third layer:	0
Infiltration On	
Infiltration rate:	0.3
Infiltration safety factor:	1
Wetted surface area On	
Total Volume Infiltrated (ac-ft.):	149.633
Total Volume Through Riser (ac-ft.):	0.867
Total Volume Through Facility (ac-ft.):	150.5
Percent Infiltrated:	99.42
Total Precip Applied to Facility:	0
Total Evap From Facility:	0
Discharge Structure	
Riser Height:	3.25 ft.
Riser Diameter:	12 in.
Element Flows To:	
Outlet 1	Outlet 2

Gravel Trench Bed Hydraulic Table

Stage(feet)	Area(ac.)	Volume(ac-ft.)	Discharge(cfs)	Infilt(cfs)
0.0000	0.093	0.000	0.000	0.000
0.0389	0.093	0.001	0.000	0.028
0.0778	0.093	0.002	0.000	0.028
0.1167	0.093	0.003	0.000	0.028
0.1556	0.093	0.005	0.000	0.028
0.1944	0.093	0.006	0.000	0.028
0.2333	0.093	0.007	0.000	0.028
0.2722	0.093	0.008	0.000	0.028
0.3111	0.093	0.010	0.000	0.028
0.3500	0.093	0.011	0.000	0.028
0.3889	0.093	0.012	0.000	0.028
0.4278	0.093	0.014	0.000	0.028
0.4667	0.093	0.015	0.000	0.028
0.5056	0.093	0.016	0.000	0.028
0.5444	0.093	0.017	0.000	0.028
0.5833	0.093	0.019	0.000	0.028
0.6222	0.093	0.020	0.000	0.028
0.6611	0.093	0.021	0.000	0.028
0.7000	0.093	0.023	0.000	0.028
0.7389	0.093	0.024	0.000	0.028
0.7778	0.093	0.025	0.000	0.028
0.8167	0.093	0.026	0.000	0.028
0.8556	0.093	0.028	0.000	0.028

0.8944	0.093	0.029	0.000	0.028
0.9333	0.093	0.030	0.000	0.028
0.9722	0.093	0.031	0.000	0.028
1.0111	0.093	0.033	0.000	0.028
1.0500	0.093	0.034	0.000	0.028
1.0889	0.093	0.035	0.000	0.028
1.1278	0.093	0.037	0.000	0.028
1.1667	0.093	0.038	0.000	0.028
1.2056	0.093	0.039	0.000	0.028
1.2444	0.093	0.040	0.000	0.028
1.2833	0.093	0.042	0.000	0.028
1.3222	0.093	0.043	0.000	0.028
1.3611	0.093	0.044	0.000	0.028
1.4000	0.093	0.045	0.000	0.028
1.4389	0.093	0.047	0.000	0.028
1.4778	0.093	0.048	0.000	0.028
1.5167	0.093	0.049	0.000	0.028
1.5556	0.093	0.051	0.000	0.028
1.5944	0.093	0.052	0.000	0.028
1.6333	0.093	0.053	0.000	0.028
1.6722	0.093	0.054	0.000	0.028
1.7111	0.093	0.056	0.000	0.028
1.7500	0.093	0.057	0.000	0.028
1.7889	0.093	0.058	0.000	0.028
1.8278	0.093	0.060	0.000	0.028
1.8667	0.093	0.061	0.000	0.028
1.9056	0.093	0.062	0.000	0.028
1.9444	0.093	0.063	0.000	0.028
1.9833	0.093	0.065	0.000	0.028
2.0222	0.093	0.066	0.000	0.028
2.0611	0.093	0.067	0.000	0.028
2.1000	0.093	0.068	0.000	0.028
2.1389	0.093	0.070	0.000	0.028
2.1778	0.093	0.071	0.000	0.028
2.2167	0.093	0.072	0.000	0.028
2.2556	0.093	0.074	0.000	0.028
2.2944	0.093	0.075	0.000	0.028
2.3333	0.093	0.076	0.000	0.028
2.3722	0.093	0.077	0.000	0.028
2.4111	0.093	0.079	0.000	0.028
2.4500	0.093	0.080	0.000	0.028
2.4889	0.093	0.081	0.000	0.028
2.5278	0.093	0.082	0.000	0.028
2.5667	0.093	0.084	0.000	0.028
2.6056	0.093	0.085	0.000	0.028
2.6444	0.093	0.086	0.000	0.028
2.6833	0.093	0.088	0.000	0.028
2.7222	0.093	0.089	0.000	0.028
2.7611	0.093	0.090	0.000	0.028
2.8000	0.093	0.091	0.000	0.028
2.8389	0.093	0.093	0.000	0.028
2.8778	0.093	0.094	0.000	0.028
2.9167	0.093	0.095	0.000	0.028
2.9556	0.093	0.097	0.000	0.028
2.9944	0.093	0.098	0.000	0.028
3.0333	0.093	0.099	0.000	0.028
3.0722	0.093	0.100	0.000	0.028
3.1111	0.093	0.102	0.000	0.028

DRAFT

3.1500	0.093	0.103	0.000	0.028
3.1889	0.093	0.104	0.000	0.028
3.2278	0.093	0.105	0.000	0.028
3.2667	0.093	0.107	0.022	0.028
3.3056	0.093	0.108	0.138	0.028
3.3444	0.093	0.109	0.306	0.028
3.3833	0.093	0.111	0.509	0.028
3.4222	0.093	0.112	0.736	0.028
3.4611	0.093	0.113	0.976	0.028
3.5000	0.093	0.114	1.217	0.028

DRAFT

Analysis Results

POC 1

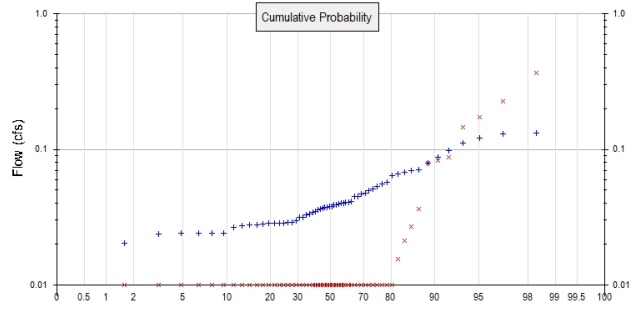
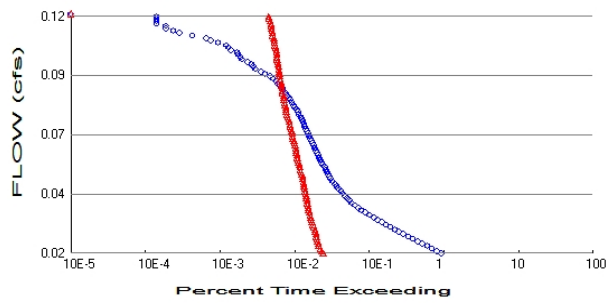

+ Predeveloped x Mitigated

Predeveloped Landuse Totals for POC #1

Total Pervious Area: 1.18
 Total Impervious Area: 0

Mitigated Landuse Totals for POC #1

Total Pervious Area: 0.66
 Total Impervious Area: 0.52

Flow Frequency Method: Log Pearson Type III 17B

Flow Frequency Return Periods for Predeveloped. POC #1

Return Period	Flow(cfs)
2 year	0.039648
5 year	0.060822
10 year	0.077152
25 year	0.100515
50 year	0.119972
100 year	0.141252

Flow Frequency Return Periods for Mitigated. POC #1

Return Period	Flow(cfs)
2 year	0
5 year	0
10 year	0
25 year	0
50 year	0
100 year	0

Annual Peaks

Annual Peaks for Predeveloped and Mitigated. POC #1

Year	Predeveloped	Mitigated
1949	0.040	0.000
1950	0.040	0.000
1951	0.036	0.000
1952	0.029	0.000
1953	0.024	0.000
1954	0.130	0.000
1955	0.051	0.000
1956	0.045	0.027
1957	0.056	0.036
1958	0.040	0.000

1959	0.040	0.000
1960	0.037	0.000
1961	0.070	0.000
1962	0.035	0.000
1963	0.057	0.000
1964	0.041	0.000
1965	0.034	0.000
1966	0.020	0.000
1967	0.041	0.000
1968	0.050	0.021
1969	0.121	0.000
1970	0.029	0.000
1971	0.045	0.000
1972	0.033	0.000
1973	0.031	0.000
1974	0.068	0.000
1975	0.028	0.000
1976	0.028	0.000
1977	0.024	0.000
1978	0.029	0.000
1979	0.079	0.000
1980	0.037	0.000
1981	0.029	0.000
1982	0.038	0.088
1983	0.064	0.000
1984	0.039	0.000
1985	0.047	0.000
1986	0.111	0.226
1987	0.053	0.079
1988	0.027	0.000
1989	0.028	0.000
1990	0.037	0.000
1991	0.038	0.000
1992	0.029	0.000
1993	0.024	0.000
1994	0.026	0.000
1995	0.039	0.000
1996	0.066	0.015
1997	0.131	0.369
1998	0.024	0.000
1999	0.032	0.000
2000	0.024	0.000
2001	0.010	0.000
2002	0.036	0.000
2003	0.028	0.000
2004	0.047	0.083
2005	0.033	0.000
2006	0.088	0.145
2007	0.070	0.000
2008	0.098	0.173
2009	0.030	0.000

DRAFT

Ranked Annual Peaks

Ranked Annual Peaks for Predeveloped and Mitigated. POC #1

Rank	Predeveloped	Mitigated
1	0.1313	0.3690
2	0.1295	0.2261
3	0.1208	0.1732

4	0.1107	0.1453
5	0.0976	0.0875
6	0.0879	0.0831
7	0.0793	0.0790
8	0.0704	0.0361
9	0.0696	0.0270
10	0.0680	0.0210
11	0.0661	0.0154
12	0.0644	0.0000
13	0.0573	0.0000
14	0.0558	0.0000
15	0.0528	0.0000
16	0.0510	0.0000
17	0.0497	0.0000
18	0.0474	0.0000
19	0.0471	0.0000
20	0.0450	0.0000
21	0.0450	0.0000
22	0.0412	0.0000
23	0.0409	0.0000
24	0.0405	0.0000
25	0.0403	0.0000
26	0.0400	0.0000
27	0.0396	0.0000
28	0.0389	0.0000
29	0.0387	0.0000
30	0.0381	0.0000
31	0.0378	0.0000
32	0.0373	0.0000
33	0.0372	0.0000
34	0.0370	0.0000
35	0.0362	0.0000
36	0.0360	0.0000
37	0.0348	0.0000
38	0.0344	0.0000
39	0.0332	0.0000
40	0.0330	0.0000
41	0.0316	0.0000
42	0.0314	0.0000
43	0.0297	0.0000
44	0.0291	0.0000
45	0.0290	0.0000
46	0.0286	0.0000
47	0.0285	0.0000
48	0.0285	0.0000
49	0.0285	0.0000
50	0.0282	0.0000
51	0.0279	0.0000
52	0.0277	0.0000
53	0.0274	0.0000
54	0.0264	0.0000
55	0.0242	0.0000
56	0.0240	0.0000
57	0.0240	0.0000
58	0.0239	0.0000
59	0.0237	0.0000
60	0.0202	0.0000
61	0.0095	0.0000

DRAFT

DRAFT

Duration Flows

Flow(cfs)	Predev	Mit	Percentage	Pass/Fail
0.0198	19607	514	2	Pass
0.0208	16996	488	2	Pass
0.0218	14677	466	3	Pass
0.0229	12739	448	3	Pass
0.0239	10919	441	4	Pass
0.0249	9437	431	4	Pass
0.0259	8168	424	5	Pass
0.0269	7078	416	5	Pass
0.0279	6130	410	6	Pass
0.0289	5313	401	7	Pass
0.0299	4656	396	8	Pass
0.0310	4066	385	9	Pass
0.0320	3548	374	10	Pass
0.0330	3136	364	11	Pass
0.0340	2759	356	12	Pass
0.0350	2449	352	14	Pass
0.0360	2147	342	15	Pass
0.0370	1892	337	17	Pass
0.0380	1656	329	19	Pass
0.0390	1508	324	21	Pass
0.0401	1370	320	23	Pass
0.0411	1250	315	25	Pass
0.0421	1154	312	27	Pass
0.0431	1069	307	28	Pass
0.0441	1009	304	30	Pass
0.0451	949	300	31	Pass
0.0461	888	294	33	Pass
0.0471	825	288	34	Pass
0.0481	777	286	36	Pass
0.0492	733	281	38	Pass
0.0502	686	278	40	Pass
0.0512	648	273	42	Pass
0.0522	622	271	43	Pass
0.0532	602	267	44	Pass
0.0542	583	259	44	Pass
0.0552	561	252	44	Pass
0.0562	538	250	46	Pass
0.0573	506	246	48	Pass
0.0583	487	241	49	Pass
0.0593	473	235	49	Pass
0.0603	457	231	50	Pass
0.0613	440	229	52	Pass
0.0623	424	224	52	Pass
0.0633	408	221	54	Pass
0.0643	394	221	56	Pass
0.0653	380	216	56	Pass
0.0664	368	212	57	Pass
0.0674	353	208	58	Pass
0.0684	341	202	59	Pass
0.0694	333	200	60	Pass
0.0704	322	197	61	Pass
0.0714	313	195	62	Pass
0.0724	302	191	63	Pass
0.0734	293	186	63	Pass

0.0745	284	185	65	Pass
0.0755	276	180	65	Pass
0.0765	265	178	67	Pass
0.0775	257	172	66	Pass
0.0785	241	168	69	Pass
0.0795	234	164	70	Pass
0.0805	226	163	72	Pass
0.0815	212	162	76	Pass
0.0825	205	158	77	Pass
0.0836	195	156	80	Pass
0.0846	187	154	82	Pass
0.0856	177	154	87	Pass
0.0866	166	152	91	Pass
0.0876	160	146	91	Pass
0.0886	150	145	96	Pass
0.0896	146	144	98	Pass
0.0906	135	141	104	Pass
0.0916	128	141	110	Pass
0.0927	120	138	115	Fail
0.0937	111	136	122	Fail
0.0947	99	135	136	Fail
0.0957	85	134	157	Fail
0.0967	75	132	176	Fail
0.0977	63	131	207	Fail
0.0987	59	130	220	Fail
0.0997	56	128	228	Fail
0.1008	50	126	252	Fail
0.1018	42	125	297	Fail
0.1028	40	123	307	Fail
0.1038	37	123	332	Fail
0.1048	36	121	336	Fail
0.1058	30	121	403	Fail
0.1068	28	119	425	Fail
0.1078	26	116	446	Fail
0.1088	20	114	570	Fail
0.1099	16	114	712	Fail
0.1109	14	112	800	Fail
0.1119	9	109	1211	Fail
0.1129	6	107	1783	Fail
0.1139	5	106	2120	Fail
0.1149	4	104	2600	Fail
0.1159	4	104	2600	Fail
0.1169	3	103	3433	Fail
0.1179	3	100	3333	Fail
0.1190	3	96	3200	Fail
0.1200	3	95	3166	Fail



See Section 4.4 for further discussion & supporting peak flow analysis.

The development has an increase in flow durations from 1/2 Predeveloped 2 year flow to the 2 year flow or more than a 10% increase from the 2 year to the 50 year flow.

Water Quality

Water Quality BMP Flow and Volume for POC #1

On-line facility volume: 0 acre-feet

On-line facility target flow: 0 cfs.

Adjusted for 15 min: 0 cfs.

Off-line facility target flow: 0 cfs.

Adjusted for 15 min: 0 cfs.

DRAFT

LID Report

LID Technique	Used for Treatment ?	Total Volume Needs Treatment (ac-ft)	Volume Through Facility (ac-ft)	Infiltration Volume (ac-ft)	Cumulative Volume Infiltration Credit	Percent Volume Infiltrated	Water Quality	Percent Water Quality Treated	Comment
Infiltration Gallery #1 POC	<input type="checkbox"/>	136.95			<input type="checkbox"/>	99.42			
Total Volume Infiltrated		136.95	0.00	0.00		99.42	0.00	0%	No Treat. Credit
Compliance with LID Standard 8% of 2-yr to 50% of 2-yr									Duration Analysis Result = Failed

DRAFT

Model Default Modifications

Total of 0 changes have been made.

PERLND Changes

No PERLND changes have been made.

IMPLND Changes

No IMPLND changes have been made.

DRAFT

Appendix
Predeveloped Schematic



Onsite Basin
1
1.18ac

Mitigated Schematic

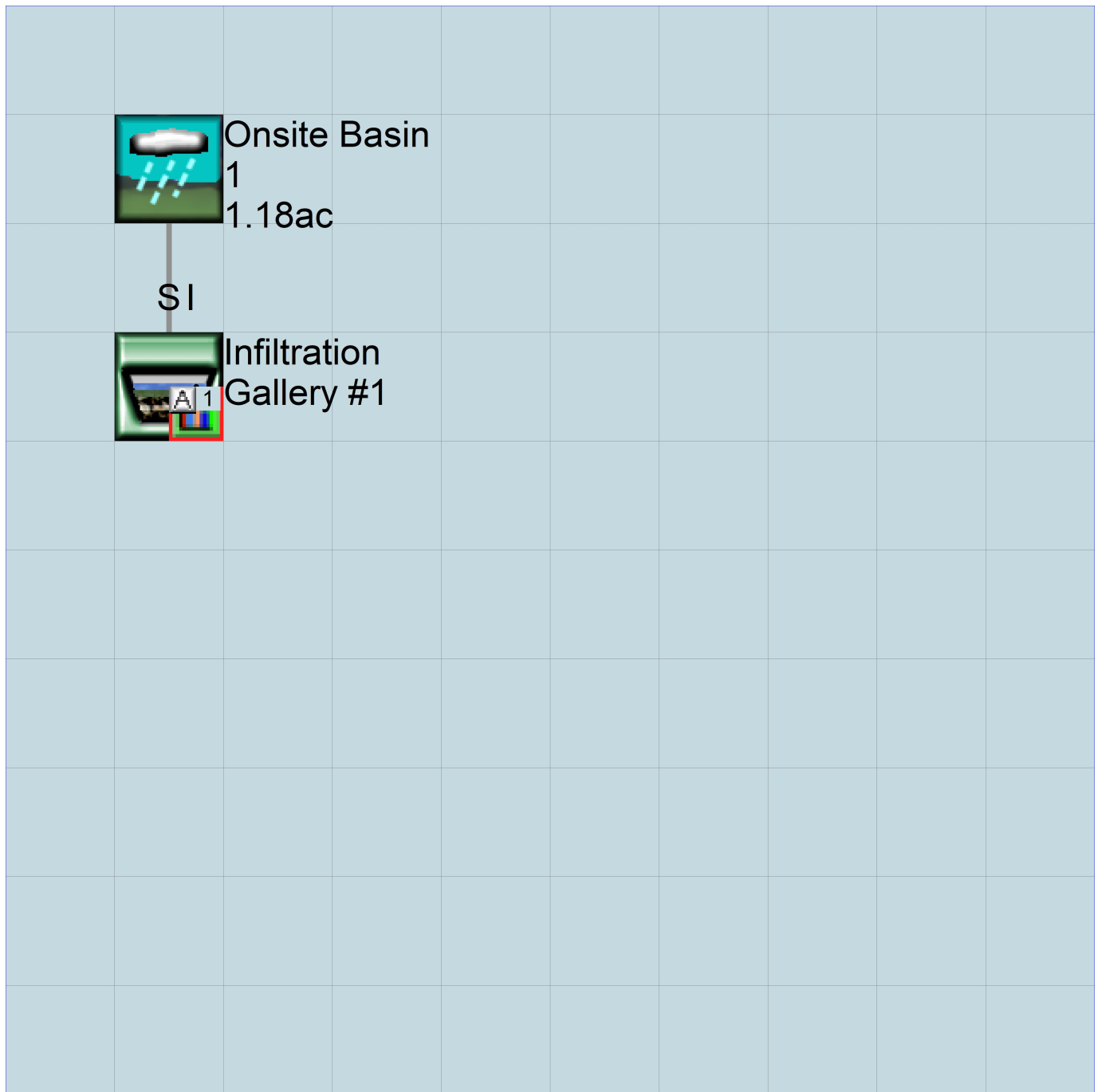

Predeveloped UCI File

RUN

GLOBAL

```
WVHM4 model simulation
START      1948 10 01      END      2009 09 30
RUN INTERP OUTPUT LEVEL   3      0
RESUME     0 RUN         1
UNIT SYSTEM 1
```

END GLOBAL

FILES

```
<File> <Un#> <-----File Name----->***
<-ID->                                     ***
WDM      26      20220822 Onsite Infiltration.wdm
MESSU    25      Pre20220822 Onsite Infiltration.MES
          27      Pre20220822 Onsite Infiltration.L61
          28      Pre20220822 Onsite Infiltration.L62
          30      POC20220822 Onsite Infiltration1.dat
```

END FILES

OPN SEQUENCE

```
INGRP          INDELT 00:15
  PERLND       10
  COPY         501
  DISPLY       1
```

END INGRP

END OPN SEQUENCE

DISPLY

DISPLY-INFO1

```
# - #<-----Title----->***TRAN PIVL DIG1 FIL1  PYR DIG2 FIL2 YRND
1      Onsite Basin 1      MAX      1      2      30      9
```

END DISPLY-INFO1

END DISPLY

COPY

TIMESERIES

```
# - # NPT NMN ***
1      1      1
501    1      1
```

END TIMESERIES

END COPY

GENER

OPCODE

```
#      # OPCD ***
```

END OPCODE

PARM

```
#      #      K ***
```

END PARM

END GENER

PERLND

GEN-INFO

```
<PLS ><-----Name----->NBLKS  Unit-systems  Printer ***
# - #      User  t-series  Engl  Metr  ***
          in  out      ***
```

```
10      C, Forest, Flat      1      1      1      1      27      0
```

END GEN-INFO

*** Section PWATER***

ACTIVITY

```
<PLS > ***** Active Sections *****
# - # ATMP SNOW PWAT  SED  PST  PWG  PQAL MSTL PEST NITR PHOS TRAC ***
10      0      0      1      0      0      0      0      0      0      0      0      0
```

END ACTIVITY

PRINT-INFO

```
<PLS > ***** Print-flags ***** PIVL  PYR
# - # ATMP SNOW PWAT  SED  PST  PWG  PQAL MSTL PEST NITR PHOS TRAC *****
10      0      0      4      0      0      0      0      0      0      0      0      0      1      9
```

END PRINT-INFO

```

PWAT-PARM1
<PLS > PWATER variable monthly parameter value flags ***
# - # CSNO RTOP UZFG VCS VUZ VNN VIFW VIRC VLE INFC HWT ***
10 0 0 0 0 0 0 0 0 0 0 0
END PWAT-PARM1

PWAT-PARM2
<PLS > PWATER input info: Part 2 ***
# - # ***FOREST LZSN INFILT LSUR SLSUR KVARY AGWRC
10 0 4.5 0.08 400 0.05 0.5 0.996
END PWAT-PARM2

PWAT-PARM3
<PLS > PWATER input info: Part 3 ***
# - # ***PETMAX PETMIN INFEXP INFILD DEEPFR BASETP AGWETP
10 0 0 2 2 0 0 0
END PWAT-PARM3

PWAT-PARM4
<PLS > PWATER input info: Part 4 ***
# - # CEPSC UZSN NSUR INTFW IRC LZETP ***
10 0.2 0.5 0.35 6 0.5 0.7
END PWAT-PARM4

PWAT-STATE1
<PLS > *** Initial conditions at start of simulation
ran from 1990 to end of 1992 (pat 1-11-95) RUN 21 ***
# - # *** CEPS SURS UZS IFWS LZS AGWS GWVS
10 0 0 0 0 2.5 1 0
END PWAT-STATE1

END PERLND

IMPLND
GEN-INFO
<PLS ><-----Name-----> Unit-systems Printer ***
# - # User t-series Engl Metr ***
in out ***

END GEN-INFO
*** Section IWATER***

ACTIVITY
<PLS > ***** Active Sections *****
# - # ATMP SNOW IWAT SLD IWG IQAL ***
END ACTIVITY

PRINT-INFO
<ILS > ***** Print-flags ***** PIVL PYR
# - # ATMP SNOW IWAT SLD IWG IQAL *****
END PRINT-INFO

IWAT-PARM1
<PLS > IWATER variable monthly parameter value flags ***
# - # CSNO RTOP VRS VNN RTLI ***
END IWAT-PARM1

IWAT-PARM2
<PLS > IWATER input info: Part 2 ***
# - # *** LSUR SLSUR NSUR RETSC
END IWAT-PARM2

IWAT-PARM3
<PLS > IWATER input info: Part 3 ***
# - # ***PETMAX PETMIN
END IWAT-PARM3

IWAT-STATE1
<PLS > *** Initial conditions at start of simulation
# - # *** RETS SURS
END IWAT-STATE1

```

END IMPLND

SCHEMATIC

<-Source->	<Name> #	<--Area-->	<-factor-->	<-Target->	MBLK	***
Onsite Basin 1***					Tbl#	***
PERLND 10		1.18		COPY 501	12	
PERLND 10		1.18		COPY 501	13	

*****Routing*****
END SCHEMATIC

NETWORK

<-Volume->	<-Grp>	<-Member->	<--Mult-->	Tran	<-Target vols>	<-Grp>	<-Member->	***
<Name> #		<Name> #	#	<-factor-->strg	<Name> #	#	<Name> #	***
COPY 501	OUTPUT	MEAN	1 1	48.4	DISPLY 1	INPUT	TIMSER 1	

<-Volume->	<-Grp>	<-Member->	<--Mult-->	Tran	<-Target vols>	<-Grp>	<-Member->	***
<Name> #		<Name> #	#	<-factor-->strg	<Name> #	#	<Name> #	***

END NETWORK

RCHRES

GEN-INFO

RCHRES	Name	Nexits	Unit Systems	Printer	***
# - #	<----->	<---->	User T-series	Engl Metr LKFG	***
			in out		***

END GEN-INFO
*** Section RCHRES***

ACTIVITY

<PLS > ***** Active Sections *****

#	-	#	HYFG	ADFG	CNFG	HTFG	SDFG	GQFG	OXFG	NUFG	PKFG	PHFG	***
#	-	#	HYFG	ADFG	CNFG	HTFG	SDFG	GQFG	OXFG	NUFG	PKFG	PHFG	***

END ACTIVITY

PRINT-INFO

<PLS > ***** Print-flags ***** PIVL PYR

#	-	#	HYDR	ADCA	CONS	HEAT	SED	GQL	OXRX	NUTR	PLNK	PHCB	PIVL	PYR	*****
#	-	#	HYDR	ADCA	CONS	HEAT	SED	GQL	OXRX	NUTR	PLNK	PHCB	PIVL	PYR	*****

END PRINT-INFO

HYDR-PARM1

RCHRES	Flags for each HYDR Section	***	ODGTFG for each	FUNCT for each	***
# - #	VC A1 A2 A3	ODFVFG for each	***	ODGTFG for each	FUNCT for each
	FG FG FG FG	possible exit	***	possible exit	possible exit
	* * * *	* * * * *		* * * * *	***

END HYDR-PARM1

HYDR-PARM2

#	-	#	FTABNO	LEN	DELTH	STCOR	KS	DB50	***
<----->	<----->	<----->	<----->	<----->	<----->	<----->	<----->	<----->	***

END HYDR-PARM2

HYDR-INIT

RCHRES	Initial conditions for each HYDR section	***
# - #	*** VOL Initial value of COLIND Initial value of OUTDGT	***
	*** ac-ft for each possible exit for each possible exit	
<----->	<----->	*** <----->

END HYDR-INIT

END RCHRES

SPEC-ACTIONS

END SPEC-ACTIONS

FTABLES

END FTABLES

EXT SOURCES

<-Volume->	<Member>	SsysSgap	<--Mult-->	Tran	<-Target vols>	<-Grp>	<-Member->	***
<Name> #	<Name> #	tem	strg	<-factor-->strg	<Name> #	#	<Name> #	***
WDM 2	PREC	ENGL	1.2		PERLND 1	999	EXTNL	PREC
WDM 2	PREC	ENGL	1.2		IMPLND 1	999	EXTNL	PREC

```
WDM      1 EVAP      ENGL      0.76          PERLND    1 999 EXTNL  PETINP
WDM      1 EVAP      ENGL      0.76          IMPLND    1 999 EXTNL  PETINP
```

END EXT SOURCES

EXT TARGETS

```
<-Volume-> <-Grp> <-Member-><--Mult-->Tran <-Volume-> <Member> Tsys Tgap Amd ***
<Name>      #      <Name> # #<-factor->strg <Name>      # <Name>      tem strg strg***
COPY      501 OUTPUT MEAN      1 1      48.4      WDM      501 FLOW      ENGL      REPL
END EXT TARGETS
```

MASS-LINK

```
<Volume>   <-Grp> <-Member-><--Mult-->      <Target>      <-Grp> <-Member->***
<Name>     #      <Name> # #<-factor->      <Name>      <Name> # #***
  MASS-LINK      12
PERLND      PWATER SURO      0.083333      COPY      INPUT  MEAN
  END MASS-LINK      12
```

```
  MASS-LINK      13
PERLND      PWATER IFWO      0.083333      COPY      INPUT  MEAN
  END MASS-LINK      13
```

END MASS-LINK

END RUN

DRAFT

Mitigated UCI File

RUN

GLOBAL

WWM4 model simulation
START 1948 10 01 END 2009 09 30
RUN INTERP OUTPUT LEVEL 3 0
RESUME 0 RUN 1 UNIT SYSTEM 1
END GLOBAL

FILES

<File>	<Un#>	<-----File Name----->	***
<-ID->			***
WDM	26	20220822 Onsite Infiltration.wdm	
MESSU	25	Mit20220822 Onsite Infiltration.MES	
	27	Mit20220822 Onsite Infiltration.L61	
	28	Mit20220822 Onsite Infiltration.L62	
	30	POC20220822 Onsite Infiltration1.dat	

END FILES

OPN SEQUENCE

INGRP INDELT 00:15

PERLND 13
IMPLND 1
IMPLND 4
IMPLND 5
IMPLND 8
RCHRES 1
COPY 1
COPY 501
DISPLY 1

END INGRP

END OPN SEQUENCE

DISPLY

DISPLY-INFO1

#	-	#	<-----Title----->	***	TRAN	PIVL	DIG1	FIL1	PYR	DIG2	FIL2	YRND
1			Infiltration Gallery #1		MAX				1	2	30	9

END DISPLY-INFO1

END DISPLY

COPY

TIMESERIES

#	-	#	NPT	NMN	***
1			1	1	
501			1	1	

END TIMESERIES

END COPY

GENER

OPCODE

OPCODE ***

END OPCODE

PARM

K ***

END PARM

END GENER

PERLND

GEN-INFO

<PLS >	<-----Name----->	NBLKS	Unit-systems	Printer	***		
#	-	#	User	t-series	Engl	Metr	***
			in	out			***
13	C, Pasture, Flat	1	1	1	1	27	0

END GEN-INFO

*** Section PWATER***

ACTIVITY

<PLS >	***** Active Sections *****														
#	-	#	ATMP	SNOW	PWAT	SED	PST	PWG	PQAL	MSTL	PEST	NITR	PHOS	TRAC	***
13			0	0	1	0	0	0	0	0	0	0	0	0	

END ACTIVITY

```

PRINT-INFO
<PLS > ***** Print-flags ***** PIVL  PYR
# - # ATMP SNOW PWAT  SED  PST  PWG  PQAL MSTL PEST NITR PHOS TRAC  *****
13   0   0   4   0   0   0   0   0   0   0   0   0   0   1   9
END PRINT-INFO

```

```

PWAT-PARM1
<PLS > PWATER variable monthly parameter value flags ***
# - # CSNO RTOP UZFG  VCS  VUZ  VNN VIFW VIRG  VLE INFC  HWT ***
13   0   0   0   0   0   0   0   0   0   0   0   0
END PWAT-PARM1

```

```

PWAT-PARM2
<PLS > PWATER input info: Part 2          ***
# - # ***FOREST  LZSN  INFILF  LRSUR  SLSUR  KVARV  AGWRC
13   0   4.5  0.06  400   0.05  0.5   0.996
END PWAT-PARM2

```

```

PWAT-PARM3
<PLS > PWATER input info: Part 3          ***
# - # ***PETMAX  PETMIN  INFEXP  INFILD  DEEPFR  BASETP  AGWETP
13   0   0   2   2   0   0   0
END PWAT-PARM3

```

```

PWAT-PARM4
<PLS > PWATER input info: Part 4          ***
# - # CEPSC  UZSN  NSUR  INTFW  IRC  LZETP ***
13   0.15  0.4  0.3  6   0.5  0.4
END PWAT-PARM4

```

```

PWAT-STATE1
<PLS > *** Initial conditions at start of simulation
ran from 1990 to end of 1992 (pat 1-11-95) RUN 21 ***
# - # *** CEPS  SURS  UZS  IFWS  LZS  AGWS  GWVS
13   0   0   0   0   2.5  1   0
END PWAT-STATE1

```

END PERLND

IMPLND

```

GEN-INFO
<PLS ><-----Name----->  Unit-systems  Printer ***
# - # User t-series Engl Metr ***
# - # in out ***
1   ROADS/FLAT  1  1  1  27  0
4   ROOF TOPS/FLAT  1  1  1  27  0
5   DRIVEWAYS/FLAT  1  1  1  27  0
8   SIDEWALKS/FLAT  1  1  1  27  0

```

```

END GEN-INFO
*** Section IWATER***

```

```

ACTIVITY
<PLS > ***** Active Sections *****
# - # ATMP SNOW IWAT  SLD  IWG IQAL  ***
1   0   0   1   0   0   0
4   0   0   1   0   0   0
5   0   0   1   0   0   0
8   0   0   1   0   0   0
END ACTIVITY

```

```

PRINT-INFO
<ILS > ***** Print-flags ***** PIVL  PYR
# - # ATMP SNOW IWAT  SLD  IWG IQAL  *****
1   0   0   4   0   0   0   1   9
4   0   0   4   0   0   0   1   9
5   0   0   4   0   0   0   1   9
8   0   0   4   0   0   0   1   9
END PRINT-INFO

```

```

IWAT-PARM1
<PLS > IWATER variable monthly parameter value flags ***

```

```

# - # CSNO RTOP VRS VNN RTLI ***
1      0 0 0 0 0
4      0 0 0 0 0
5      0 0 0 0 0
8      0 0 0 0 0

```

END IWAT-PARM1

IWAT-PARM2

```

<PLS > IWATER input info: Part 2 ***
# - # *** LSUR SLSUR NSUR RETSC
1      400 0.01 0.1 0.1
4      400 0.01 0.1 0.1
5      400 0.01 0.1 0.1
8      400 0.01 0.1 0.1

```

END IWAT-PARM2

IWAT-PARM3

```

<PLS > IWATER input info: Part 3 ***
# - # ***PETMAX PETMIN
1      0 0
4      0 0
5      0 0
8      0 0

```

END IWAT-PARM3

IWAT-STATE1

```

<PLS > *** Initial conditions at start of simulation
# - # *** RETS SURS
1      0 0
4      0 0
5      0 0
8      0 0

```

END IWAT-STATE1

END IMPLND

SCHEMATIC

```

<-Source-> <--Area--> <-Target-> MBLK ***
<Name> # <-factor--> <Name> # Tbl# ***
Onsite Basin 1***
PERLND 13 0.66 RCHRES 1 2
PERLND 13 0.66 RCHRES 1 3
IMPLND 1 0.19 RCHRES 1 5
IMPLND 4 0.24 RCHRES 1 5
IMPLND 5 0.03 RCHRES 1 5
IMPLND 8 0.06 RCHRES 1 5

```

*****Routing*****

```

PERLND 13 0.66 COPY 1 12
IMPLND 1 0.19 COPY 1 15
IMPLND 4 0.24 COPY 1 15
IMPLND 5 0.03 COPY 1 15
IMPLND 8 0.06 COPY 1 15
PERLND 13 0.66 COPY 1 13
RCHRES 1 1 COPY 501 17

```

END SCHEMATIC

NETWORK

```

<-Volume-> <-Grp> <-Member-><--Mult-->Tran <-Target vols> <-Grp> <-Member-> ***
<Name> # <Name> # #<-factor-->strg <Name> # # <Name> # # ***
COPY 501 OUTPUT MEAN 1 1 48.4 DISPLY 1 INPUT TIMSER 1

```

```

<-Volume-> <-Grp> <-Member-><--Mult-->Tran <-Target vols> <-Grp> <-Member-> ***
<Name> # <Name> # #<-factor-->strg <Name> # # <Name> # # ***
END NETWORK

```

RCHRES

GEN-INFO

```

RCHRES      Name      Nexits  Unit Systems  Printer      ***
# - #<-----><----> User T-series  Engl Metr LKFG  ***
              in  out
1      Infiltration Gal-016    2    1    1    1    28    0    1
END GEN-INFO
*** Section RCHRES***

```

```

ACTIVITY
<PLS > ***** Active Sections *****
# - # HYFG ADFG CNFG HTFG SDFG GQFG OXFG NUGF PKFG PHFG ***
1      1    0    0    0    0    0    0    0    0    0
END ACTIVITY

```

```

PRINT-INFO
<PLS > ***** Print-flags ***** PIVL  PYR
# - # HYDR ADCA CONS HEAT  SED  GQL  OXRX NUTR  PLNK PHCB  PIVL  PYR  *****
1      4    0    0    0    0    0    0    0    0    0    1    9
END PRINT-INFO

```

```

HYDR-PARM1
RCHRES  Flags for each HYDR Section      ***
# - # VC A1 A2 A3  ODFVFG for each *** ODGTFG for each  FUNCT for each
      FG FG FG FG  possible exit *** possible exit  possible exit
      * * * * * * * * * * * * * * * * * * * * * * * * * * * * * * * * * * * *
1      0 1 0 0    4 5 0 0 0    0 0 0 0 0    2 2 2 2 2
END HYDR-PARM1

```

```

HYDR-PARM2
# - # FTABNO      LEN      DELTH      STCOR      KS      DB50      ***
<---><-----><-----><-----><-----><-----><----->
1      1      0.01      0.0      0.0      0.5      0.0
END HYDR-PARM2

```

```

HYDR-INIT
RCHRES  Initial conditions for each HYDR section      ***
# - # *** VOL      Initial value of COLIND      Initial value of OUTDGT
      *** ac-ft      for each possible exit      for each possible exit
<---><-----><-----><-----><-----><-----><-----><-----><-----><----->
1      0      4.0 5.0 0.0 0.0 0.0      0.0 0.0 0.0 0.0 0.0
END HYDR-INIT
END RCHRES

```

```

SPEC-ACTIONS
END SPEC-ACTIONS
FTABLES

```

```

FTABLE      1
92      5
Depth      Area      Volume      Outflow1      Outflow2      Velocity      Travel Time***
(ft)      (acres)      (acre-ft)      (cfs)      (cfs)      (ft/sec)      (Minutes)***
0.000000  0.093738  0.000000  0.000000  0.000000
0.038889  0.093738  0.001276  0.000000  0.028356
0.077778  0.093738  0.002552  0.000000  0.028356
0.116667  0.093738  0.003828  0.000000  0.028356
0.155556  0.093738  0.005103  0.000000  0.028356
0.194444  0.093738  0.006379  0.000000  0.028356
0.233333  0.093738  0.007655  0.000000  0.028356
0.272222  0.093738  0.008931  0.000000  0.028356
0.311111  0.093738  0.010207  0.000000  0.028356
0.350000  0.093738  0.011483  0.000000  0.028356
0.388889  0.093738  0.012759  0.000000  0.028356
0.427778  0.093738  0.014035  0.000000  0.028356
0.466667  0.093738  0.015310  0.000000  0.028356
0.505556  0.093738  0.016586  0.000000  0.028356
0.544444  0.093738  0.017862  0.000000  0.028356
0.583333  0.093738  0.019138  0.000000  0.028356
0.622222  0.093738  0.020414  0.000000  0.028356
0.661111  0.093738  0.021690  0.000000  0.028356
0.700000  0.093738  0.022966  0.000000  0.028356
0.738889  0.093738  0.024242  0.000000  0.028356
0.777778  0.093738  0.025517  0.000000  0.028356
0.816667  0.093738  0.026793  0.000000  0.028356

```

0.855556	0.093738	0.028069	0.000000	0.028356
0.894444	0.093738	0.029345	0.000000	0.028356
0.933333	0.093738	0.030621	0.000000	0.028356
0.972222	0.093738	0.031897	0.000000	0.028356
1.011111	0.093738	0.033173	0.000000	0.028356
1.050000	0.093738	0.034449	0.000000	0.028356
1.088889	0.093738	0.035724	0.000000	0.028356
1.127778	0.093738	0.037000	0.000000	0.028356
1.166667	0.093738	0.038276	0.000000	0.028356
1.205556	0.093738	0.039552	0.000000	0.028356
1.244444	0.093738	0.040828	0.000000	0.028356
1.283333	0.093738	0.042104	0.000000	0.028356
1.322222	0.093738	0.043380	0.000000	0.028356
1.361111	0.093738	0.044656	0.000000	0.028356
1.400000	0.093738	0.045931	0.000000	0.028356
1.438889	0.093738	0.047207	0.000000	0.028356
1.477778	0.093738	0.048483	0.000000	0.028356
1.516667	0.093738	0.049759	0.000000	0.028356
1.555556	0.093738	0.051035	0.000000	0.028356
1.594444	0.093738	0.052311	0.000000	0.028356
1.633333	0.093738	0.053587	0.000000	0.028356
1.672222	0.093738	0.054863	0.000000	0.028356
1.711111	0.093738	0.056138	0.000000	0.028356
1.750000	0.093738	0.057414	0.000000	0.028356
1.788889	0.093738	0.058690	0.000000	0.028356
1.827778	0.093738	0.059966	0.000000	0.028356
1.866667	0.093738	0.061242	0.000000	0.028356
1.905556	0.093738	0.062518	0.000000	0.028356
1.944444	0.093738	0.063794	0.000000	0.028356
1.983333	0.093738	0.065070	0.000000	0.028356
2.022222	0.093738	0.066345	0.000000	0.028356
2.061111	0.093738	0.067621	0.000000	0.028356
2.100000	0.093738	0.068897	0.000000	0.028356
2.138889	0.093738	0.070173	0.000000	0.028356
2.177778	0.093738	0.071449	0.000000	0.028356
2.216667	0.093738	0.072725	0.000000	0.028356
2.255556	0.093738	0.074001	0.000000	0.028356
2.294444	0.093738	0.075277	0.000000	0.028356
2.333333	0.093738	0.076552	0.000000	0.028356
2.372222	0.093738	0.077828	0.000000	0.028356
2.411111	0.093738	0.079104	0.000000	0.028356
2.450000	0.093738	0.080380	0.000000	0.028356
2.488889	0.093738	0.081656	0.000000	0.028356
2.527778	0.093738	0.082932	0.000000	0.028356
2.566667	0.093738	0.084208	0.000000	0.028356
2.605556	0.093738	0.085483	0.000000	0.028356
2.644444	0.093738	0.086759	0.000000	0.028356
2.683333	0.093738	0.088035	0.000000	0.028356
2.722222	0.093738	0.089311	0.000000	0.028356
2.761111	0.093738	0.090587	0.000000	0.028356
2.800000	0.093738	0.091863	0.000000	0.028356
2.838889	0.093738	0.093139	0.000000	0.028356
2.877778	0.093738	0.094415	0.000000	0.028356
2.916667	0.093738	0.095690	0.000000	0.028356
2.955556	0.093738	0.096966	0.000000	0.028356
2.994444	0.093738	0.098242	0.000000	0.028356
3.033333	0.093738	0.099518	0.000000	0.028356
3.072222	0.093738	0.100794	0.000000	0.028356
3.111111	0.093738	0.102070	0.000000	0.028356
3.150000	0.093738	0.103346	0.000000	0.028356
3.188889	0.093738	0.104622	0.000000	0.028356
3.227778	0.093738	0.105897	0.000000	0.028356
3.266667	0.093738	0.107173	0.022834	0.028356
3.305556	0.093738	0.108449	0.138729	0.028356
3.344444	0.093738	0.109725	0.306376	0.028356
3.383333	0.093738	0.111001	0.509662	0.028356
3.422222	0.093738	0.112277	0.736941	0.028356
3.461111	0.093738	0.113553	0.976818	0.028356
3.500000	0.093738	0.114829	1.217555	0.028356
3.538889	0.093738	0.118474	1.447495	0.028356

END FTABLE 1
END FTABLES

EXT SOURCES

```
<-Volume-> <Member> SsysSgap<--Mult-->Tran <-Target vols> <-Grp> <-Member-> ***  
<Name> # <Name> # tem strg<-factor-->strg <Name> # # <Name> # # ***  
WDM 2 PREC ENGL 1.2 PERLND 1 999 EXTNL PREC  
WDM 2 PREC ENGL 1.2 IMPLND 1 999 EXTNL PREC  
WDM 1 EVAP ENGL 0.76 PERLND 1 999 EXTNL PETINP  
WDM 1 EVAP ENGL 0.76 IMPLND 1 999 EXTNL PETINP
```

END EXT SOURCES

EXT TARGETS

```
<-Volume-> <-Grp> <-Member-><--Mult-->Tran <-Volume-> <Member> Tsys Tgap Amd ***  
<Name> # <Name> # #<-factor-->strg <Name> # <Name> tem strg strg***  
RCHRES 1 HYDR RO 1 1 1 WDM 1004 FLOW ENGL REPL  
RCHRES 1 HYDR O 1 1 1 WDM 1005 FLOW ENGL REPL  
RCHRES 1 HYDR O 2 1 1 WDM 1006 FLOW ENGL REPL  
RCHRES 1 HYDR STAGE 1 1 1 WDM 1007 STAG ENGL REPL  
COPY 1 OUTPUT MEAN 1 1 48.4 WDM 701 FLOW ENGL REPL  
COPY 501 OUTPUT MEAN 1 1 48.4 WDM 801 FLOW ENGL REPL  
END EXT TARGETS
```

MASS-LINK

```
<Volume> <-Grp> <-Member-><--Mult--> <Target> <-Grp> <-Member->***  
<Name> <Name> # #<-factor--> <Name> <Name> # #***  
MASS-LINK 2  
PERLND PWATER SURO 0.083333 RCHRES INFLOW IVOL  
END MASS-LINK 2  
  
MASS-LINK 3  
PERLND PWATER IFWO 0.083333 RCHRES INFLOW IVOL  
END MASS-LINK 3  
  
MASS-LINK 5  
IMPLND IWATER SURO 0.083333 RCHRES INFLOW IVOL  
END MASS-LINK 5  
  
MASS-LINK 12  
PERLND PWATER SURO 0.083333 COPY INPUT MEAN  
END MASS-LINK 12  
  
MASS-LINK 13  
PERLND PWATER IFWO 0.083333 COPY INPUT MEAN  
END MASS-LINK 13  
  
MASS-LINK 15  
IMPLND IWATER SURO 0.083333 COPY INPUT MEAN  
END MASS-LINK 15  
  
MASS-LINK 17  
RCHRES OFLOW OVOL 1 COPY INPUT MEAN  
END MASS-LINK 17
```

END MASS-LINK

END RUN

DRAFT

DRAFT

Disclaimer

Legal Notice

This program and accompanying documentation are provided 'as-is' without warranty of any kind. The entire risk regarding the performance and results of this program is assumed by End User. Clear Creek Solutions Inc. and the governmental licensee or sublicensees disclaim all warranties, either expressed or implied, including but not limited to implied warranties of program and accompanying documentation. In no event shall Clear Creek Solutions Inc. be liable for any damages whatsoever (including without limitation to damages for loss of business profits, loss of business information, business interruption, and the like) arising out of the use of, or inability to use this program even if Clear Creek Solutions Inc. or their authorized representatives have been advised of the possibility of such damages. Software Copyright © by : Clear Creek Solutions, Inc. 2005-2022; All Rights Reserved.

Clear Creek Solutions, Inc.
6200 Capitol Blvd. Ste F
Olympia, WA. 98501
Toll Free 1(866)943-0304
Local (360)943-0304

www.clearcreeksolutions.com

DRAFT

WWHM2012

PROJECT REPORT

INFILTRATION GALLERY 2

General Model Information

Project Name: 20220816 Lot 5_Roof Infiltration
Site Name:
Site Address:
City:
Report Date: 9/9/2022
Gage: Everett
Data Start: 1948/10/01
Data End: 2009/09/30
Timestep: 15 Minute
Precip Scale: 1.200
Version Date: 2021/08/18
Version: 4.2.18

POC Thresholds

Low Flow Threshold for POC1: 50 Percent of the 2 Year
High Flow Threshold for POC1: 50 Year

DRAFT

Landuse Basin Data
Predeveloped Land Use

Onsite Basin 2

Bypass:	No
GroundWater:	No
Pervious Land Use C, Forest, Flat	acre 0.06
Pervious Total	0.06
Impervious Land Use	acre
Impervious Total	0
Basin Total	0.06

Element Flows To:
Surface Interflow Groundwater

DRAFT

Mitigated Land Use

Onsite Basin 2

Bypass:	No
GroundWater:	No
Pervious Land Use	acre
Pervious Total	0
Impervious Land Use	acre
ROOF TOPS FLAT	0.06
Impervious Total	0.06
Basin Total	0.06

Element Flows To:

Surface	Interflow	Groundwater
Infiltration Gallery #2	Infiltration Gallery #2	

DRAFT

Routing Elements
Predeveloped Routing

DRAFT

Mitigated Routing

Infiltration Gallery #2

Bottom Length:	25.10 ft.
Bottom Width:	25.10 ft.
Trench bottom slope 1:	0 To 1
Trench Left side slope 0:	0 To 1
Trench right side slope 2:	0 To 1
Material thickness of first layer:	2.5
Pour Space of material for first layer:	0.35
Material thickness of second layer:	0
Pour Space of material for second layer:	0
Material thickness of third layer:	0
Pour Space of material for third layer:	0
Infiltration On	
Infiltration rate:	0.3
Infiltration safety factor:	1
Wetted surface area On	
Total Volume Infiltrated (ac-ft.):	11.593
Total Volume Through Riser (ac-ft.):	0.011
Total Volume Through Facility (ac-ft.):	11.604
Percent Infiltrated:	99.91
Total Precip Applied to Facility:	0
Total Evap From Facility:	0
Discharge Structure	
Riser Height:	2.4 ft.
Riser Diameter:	12 in.
Element Flows To:	
Outlet 1	Outlet 2

Gravel Trench Bed Hydraulic Table

Stage(feet)	Area(ac.)	Volume(ac-ft.)	Discharge(cfs)	Infilt(cfs)
0.0000	0.014	0.000	0.000	0.000
0.0278	0.014	0.000	0.000	0.004
0.0556	0.014	0.000	0.000	0.004
0.0833	0.014	0.000	0.000	0.004
0.1111	0.014	0.000	0.000	0.004
0.1389	0.014	0.000	0.000	0.004
0.1667	0.014	0.000	0.000	0.004
0.1944	0.014	0.001	0.000	0.004
0.2222	0.014	0.001	0.000	0.004
0.2500	0.014	0.001	0.000	0.004
0.2778	0.014	0.001	0.000	0.004
0.3056	0.014	0.001	0.000	0.004
0.3333	0.014	0.001	0.000	0.004
0.3611	0.014	0.001	0.000	0.004
0.3889	0.014	0.002	0.000	0.004
0.4167	0.014	0.002	0.000	0.004
0.4444	0.014	0.002	0.000	0.004
0.4722	0.014	0.002	0.000	0.004
0.5000	0.014	0.002	0.000	0.004
0.5278	0.014	0.002	0.000	0.004
0.5556	0.014	0.002	0.000	0.004
0.5833	0.014	0.003	0.000	0.004
0.6111	0.014	0.003	0.000	0.004

0.6389	0.014	0.003	0.000	0.004
0.6667	0.014	0.003	0.000	0.004
0.6944	0.014	0.003	0.000	0.004
0.7222	0.014	0.003	0.000	0.004
0.7500	0.014	0.003	0.000	0.004
0.7778	0.014	0.003	0.000	0.004
0.8056	0.014	0.004	0.000	0.004
0.8333	0.014	0.004	0.000	0.004
0.8611	0.014	0.004	0.000	0.004
0.8889	0.014	0.004	0.000	0.004
0.9167	0.014	0.004	0.000	0.004
0.9444	0.014	0.004	0.000	0.004
0.9722	0.014	0.004	0.000	0.004
1.0000	0.014	0.005	0.000	0.004
1.0278	0.014	0.005	0.000	0.004
1.0556	0.014	0.005	0.000	0.004
1.0833	0.014	0.005	0.000	0.004
1.1111	0.014	0.005	0.000	0.004
1.1389	0.014	0.005	0.000	0.004
1.1667	0.014	0.005	0.000	0.004
1.1944	0.014	0.006	0.000	0.004
1.2222	0.014	0.006	0.000	0.004
1.2500	0.014	0.006	0.000	0.004
1.2778	0.014	0.006	0.000	0.004
1.3056	0.014	0.006	0.000	0.004
1.3333	0.014	0.006	0.000	0.004
1.3611	0.014	0.006	0.000	0.004
1.3889	0.014	0.007	0.000	0.004
1.4167	0.014	0.007	0.000	0.004
1.4444	0.014	0.007	0.000	0.004
1.4722	0.014	0.007	0.000	0.004
1.5000	0.014	0.007	0.000	0.004
1.5278	0.014	0.007	0.000	0.004
1.5556	0.014	0.007	0.000	0.004
1.5833	0.014	0.008	0.000	0.004
1.6111	0.014	0.008	0.000	0.004
1.6389	0.014	0.008	0.000	0.004
1.6667	0.014	0.008	0.000	0.004
1.6944	0.014	0.008	0.000	0.004
1.7222	0.014	0.008	0.000	0.004
1.7500	0.014	0.008	0.000	0.004
1.7778	0.014	0.009	0.000	0.004
1.8056	0.014	0.009	0.000	0.004
1.8333	0.014	0.009	0.000	0.004
1.8611	0.014	0.009	0.000	0.004
1.8889	0.014	0.009	0.000	0.004
1.9167	0.014	0.009	0.000	0.004
1.9444	0.014	0.009	0.000	0.004
1.9722	0.014	0.010	0.000	0.004
2.0000	0.014	0.010	0.000	0.004
2.0278	0.014	0.010	0.000	0.004
2.0556	0.014	0.010	0.000	0.004
2.0833	0.014	0.010	0.000	0.004
2.1111	0.014	0.010	0.000	0.004
2.1389	0.014	0.010	0.000	0.004
2.1667	0.014	0.011	0.000	0.004
2.1944	0.014	0.011	0.000	0.004
2.2222	0.014	0.011	0.000	0.004

DRAFT

2.2500	0.014	0.011	0.000	0.004
2.2778	0.014	0.011	0.000	0.004
2.3056	0.014	0.011	0.000	0.004
2.3333	0.014	0.011	0.000	0.004
2.3611	0.014	0.012	0.000	0.004
2.3889	0.014	0.012	0.000	0.004
2.4167	0.014	0.012	0.022	0.004
2.4444	0.014	0.012	0.099	0.004
2.4722	0.014	0.012	0.205	0.004
2.5000	0.014	0.012	0.333	0.004

DRAFT

Analysis Results

POC 1

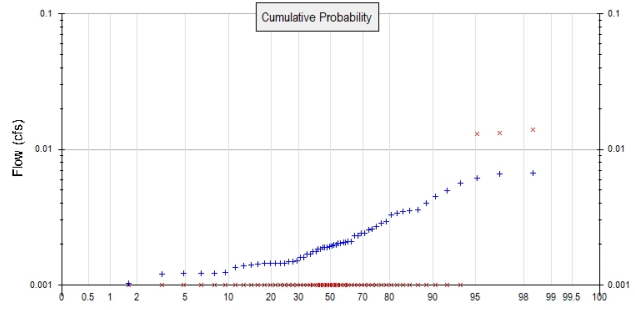
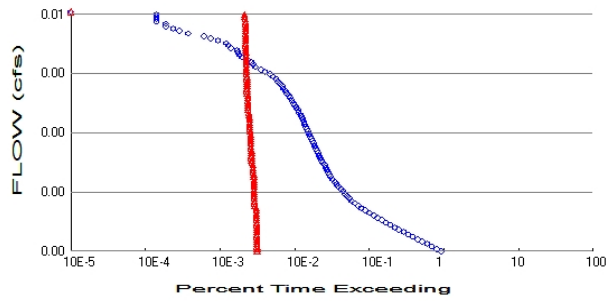

+ Predeveloped x Mitigated

Predeveloped Landuse Totals for POC #1

Total Pervious Area: 0.06
Total Impervious Area: 0

Mitigated Landuse Totals for POC #1

Total Pervious Area: 0
Total Impervious Area: 0.06

Flow Frequency Method: Log Pearson Type III 17B

Flow Frequency Return Periods for Predeveloped. POC #1

Return Period	Flow(cfs)
2 year	0.002016
5 year	0.003093
10 year	0.003923
25 year	0.005111
50 year	0.0061
100 year	0.007182

Flow Frequency Return Periods for Mitigated. POC #1

Return Period	Flow(cfs)
2 year	0
5 year	0
10 year	0
25 year	0
50 year	0
100 year	0

Annual Peaks

Annual Peaks for Predeveloped and Mitigated. POC #1

Year	Predeveloped	Mitigated
1949	0.002	0.000
1950	0.002	0.000
1951	0.002	0.000
1952	0.001	0.000
1953	0.001	0.000
1954	0.007	0.000
1955	0.003	0.000
1956	0.002	0.000
1957	0.003	0.000
1958	0.002	0.000

1959	0.002	0.000
1960	0.002	0.000
1961	0.004	0.000
1962	0.002	0.000
1963	0.003	0.000
1964	0.002	0.000
1965	0.002	0.000
1966	0.001	0.000
1967	0.002	0.000
1968	0.003	0.000
1969	0.006	0.000
1970	0.001	0.000
1971	0.002	0.000
1972	0.002	0.000
1973	0.002	0.000
1974	0.003	0.000
1975	0.001	0.000
1976	0.001	0.000
1977	0.001	0.000
1978	0.001	0.000
1979	0.004	0.000
1980	0.002	0.000
1981	0.001	0.000
1982	0.002	0.000
1983	0.003	0.000
1984	0.002	0.000
1985	0.002	0.000
1986	0.006	0.014
1987	0.003	0.000
1988	0.001	0.000
1989	0.001	0.000
1990	0.002	0.000
1991	0.002	0.000
1992	0.001	0.000
1993	0.001	0.000
1994	0.001	0.000
1995	0.002	0.000
1996	0.003	0.000
1997	0.007	0.013
1998	0.001	0.000
1999	0.002	0.000
2000	0.001	0.000
2001	0.000	0.000
2002	0.002	0.000
2003	0.001	0.000
2004	0.002	0.000
2005	0.002	0.000
2006	0.004	0.000
2007	0.004	0.000
2008	0.005	0.013
2009	0.002	0.000

DRAFT

Ranked Annual Peaks

Ranked Annual Peaks for Predeveloped and Mitigated. POC #1

Rank	Predeveloped	Mitigated
1	0.0067	0.0140
2	0.0066	0.0133
3	0.0061	0.0130

4	0.0056	0.0000
5	0.0050	0.0000
6	0.0045	0.0000
7	0.0040	0.0000
8	0.0036	0.0000
9	0.0035	0.0000
10	0.0035	0.0000
11	0.0034	0.0000
12	0.0033	0.0000
13	0.0029	0.0000
14	0.0028	0.0000
15	0.0027	0.0000
16	0.0026	0.0000
17	0.0025	0.0000
18	0.0024	0.0000
19	0.0024	0.0000
20	0.0023	0.0000
21	0.0023	0.0000
22	0.0021	0.0000
23	0.0021	0.0000
24	0.0021	0.0000
25	0.0021	0.0000
26	0.0020	0.0000
27	0.0020	0.0000
28	0.0020	0.0000
29	0.0020	0.0000
30	0.0019	0.0000
31	0.0019	0.0000
32	0.0019	0.0000
33	0.0019	0.0000
34	0.0019	0.0000
35	0.0018	0.0000
36	0.0018	0.0000
37	0.0018	0.0000
38	0.0018	0.0000
39	0.0017	0.0000
40	0.0017	0.0000
41	0.0016	0.0000
42	0.0016	0.0000
43	0.0015	0.0000
44	0.0015	0.0000
45	0.0015	0.0000
46	0.0015	0.0000
47	0.0014	0.0000
48	0.0014	0.0000
49	0.0014	0.0000
50	0.0014	0.0000
51	0.0014	0.0000
52	0.0014	0.0000
53	0.0014	0.0000
54	0.0013	0.0000
55	0.0012	0.0000
56	0.0012	0.0000
57	0.0012	0.0000
58	0.0012	0.0000
59	0.0012	0.0000
60	0.0010	0.0000
61	0.0005	0.0000

DRAFT

DRAFT

Duration Flows

Flow(cfs)	Predev	Mit	Percentage	Pass/Fail
0.0010	19590	67	0	Pass
0.0011	17002	67	0	Pass
0.0011	14692	67	0	Pass
0.0012	12733	66	0	Pass
0.0012	10940	66	0	Pass
0.0013	9439	66	0	Pass
0.0013	8175	66	0	Pass
0.0014	7075	66	0	Pass
0.0014	6136	66	1	Pass
0.0015	5319	66	1	Pass
0.0015	4656	66	1	Pass
0.0016	4075	66	1	Pass
0.0016	3548	66	1	Pass
0.0017	3140	65	2	Pass
0.0017	2759	65	2	Pass
0.0018	2449	65	2	Pass
0.0018	2154	65	3	Pass
0.0019	1894	65	3	Pass
0.0019	1657	65	3	Pass
0.0020	1508	62	4	Pass
0.0020	1370	62	4	Pass
0.0021	1250	62	4	Pass
0.0021	1154	61	5	Pass
0.0022	1071	61	5	Pass
0.0022	1009	61	6	Pass
0.0023	950	61	6	Pass
0.0023	888	61	6	Pass
0.0024	825	61	7	Pass
0.0024	777	61	7	Pass
0.0025	734	61	8	Pass
0.0026	686	61	8	Pass
0.0026	648	60	9	Pass
0.0027	622	60	9	Pass
0.0027	602	59	9	Pass
0.0028	583	59	10	Pass
0.0028	561	59	10	Pass
0.0029	538	59	10	Pass
0.0029	506	57	11	Pass
0.0030	487	56	11	Pass
0.0030	473	56	11	Pass
0.0031	457	56	12	Pass
0.0031	440	56	12	Pass
0.0032	424	56	13	Pass
0.0032	410	55	13	Pass
0.0033	394	55	13	Pass
0.0033	380	55	14	Pass
0.0034	368	55	14	Pass
0.0034	353	55	15	Pass
0.0035	341	55	16	Pass
0.0035	333	55	16	Pass
0.0036	322	54	16	Pass
0.0036	313	53	16	Pass
0.0037	303	53	17	Pass
0.0037	293	53	18	Pass

DRAFT

0.0038	284	53	18	Pass
0.0038	276	53	19	Pass
0.0039	265	53	20	Pass
0.0039	257	52	20	Pass
0.0040	241	52	21	Pass
0.0040	234	50	21	Pass
0.0041	225	50	22	Pass
0.0041	212	50	23	Pass
0.0042	205	50	24	Pass
0.0042	195	50	25	Pass
0.0043	187	50	26	Pass
0.0044	177	50	28	Pass
0.0044	166	49	29	Pass
0.0045	160	49	30	Pass
0.0045	150	49	32	Pass
0.0046	146	49	33	Pass
0.0046	135	49	36	Pass
0.0047	128	49	38	Pass
0.0047	120	49	40	Pass
0.0048	111	49	44	Pass
0.0048	99	48	48	Pass
0.0049	85	48	56	Pass
0.0049	75	48	64	Pass
0.0050	63	48	76	Pass
0.0050	59	48	81	Pass
0.0051	56	48	85	Pass
0.0051	50	48	96	Pass
0.0052	42	48	114	Fail
0.0052	39	48	123	Fail
0.0053	37	48	129	Fail
0.0053	36	47	130	Fail
0.0054	30	47	156	Fail
0.0054	28	47	167	Fail
0.0055	26	47	180	Fail
0.0055	20	47	234	Fail
0.0056	16	47	293	Fail
0.0056	13	47	361	Fail
0.0057	8	47	587	Fail
0.0057	6	47	783	Fail
0.0058	5	47	939	Fail
0.0058	4	47	1175	Fail
0.0059	4	47	1175	Fail
0.0059	3	47	1566	Fail
0.0060	3	46	1533	Fail
0.0060	3	45	1500	Fail
0.0061	3	45	1500	Fail

DRAFT

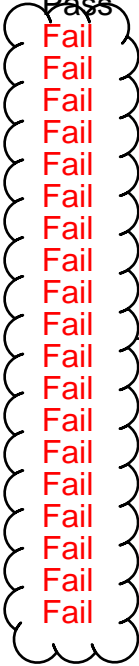

See Section 4.4 for further discussion & supporting peak flow analysis.

The development has an increase in flow durations from 1/2 Predeveloped 2 year flow to the 2 year flow or more than a 10% increase from the 2 year to the 50 year flow.

Water Quality

Water Quality BMP Flow and Volume for POC #1

On-line facility volume: 0 acre-feet

On-line facility target flow: 0 cfs.

Adjusted for 15 min: 0 cfs.

Off-line facility target flow: 0 cfs.

Adjusted for 15 min: 0 cfs.

DRAFT

LID Report

LID Technique	Used for Treatment ?	Total Volume Needs Treatment (ac-ft)	Volume Through Facility (ac-ft)	Infiltration Volume (ac-ft)	Cumulative Volume Infiltration Credit	Percent Volume Infiltrated	Water Quality	Percent Water Quality Treated	Comment
Infiltration Gallery #2 POC	<input type="checkbox"/>	10.56			<input type="checkbox"/>	99.91			
Total Volume Infiltrated		10.56	0.00	0.00		99.91	0.00	0%	No Treat. Credit
Compliance with LID Standard 8% of 2-yr to 50% of 2-yr									Duration Analysis Result = Failed

DRAFT

Model Default Modifications

Total of 0 changes have been made.

PERLND Changes

No PERLND changes have been made.

IMPLND Changes

No IMPLND changes have been made.

DRAFT

Appendix
Predeveloped Schematic



Onsite Basin
2
0.06ac

Mitigated Schematic

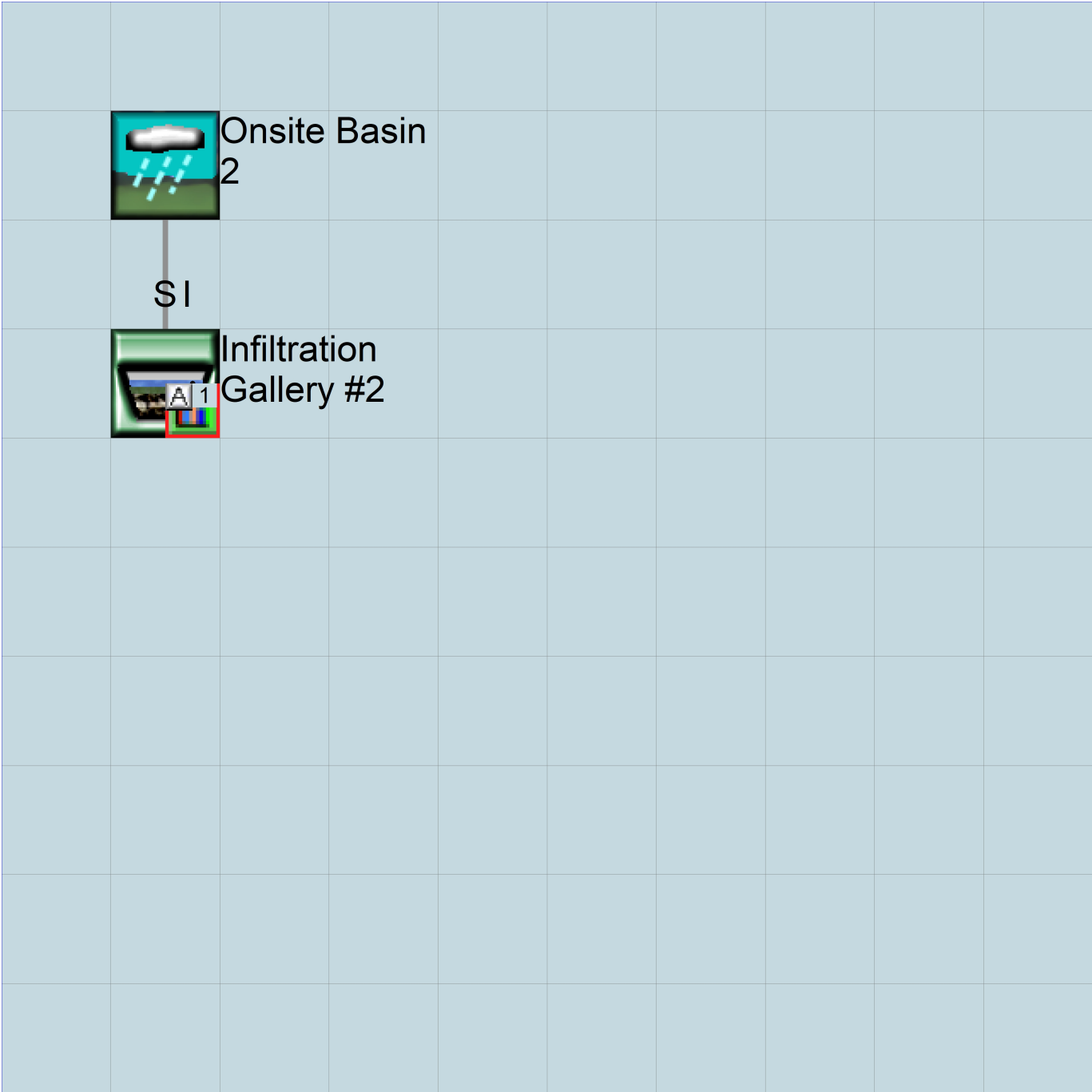

Predeveloped UCI File

RUN

GLOBAL

WWM4 model simulation
START 1948 10 01 END 2009 09 30
RUN INTERP OUTPUT LEVEL 3 0
RESUME 0 RUN 1 UNIT SYSTEM 1
END GLOBAL

FILES

```
<File> <Un#> <-----File Name----->***  
<-ID-> ***  
WDM 26 20220816 Lot 5_Roof Infiltration.wdm  
MESSU 25 Pre20220816 Lot 5_Roof Infiltration.MES  
27 Pre20220816 Lot 5_Roof Infiltration.L61  
28 Pre20220816 Lot 5_Roof Infiltration.L62  
30 POC20220816 Lot 5_Roof Infiltration1.dat
```

END FILES

OPN SEQUENCE

INGRP INDELT 00:15
PERLND 10
COPY 501
DISPLY 1

END INGRP

END OPN SEQUENCE

DISPLY

DISPLY-INFO1

```
# - #<-----Title----->***TRAN PIVL DIG1 FIL1 PYR DIG2 FIL2 YRND  
1 Onsite Basin 2 MAX 1 2 30 9
```

END DISPLY-INFO1

END DISPLY

COPY

TIMESERIES

```
# - # NPT NMN ***  
1 1 1  
501 1 1
```

END TIMESERIES

END COPY

GENER

OPCODE

```
# # OPCODE ***
```

END OPCODE

PARAM

```
# # K ***
```

END PARAM

END GENER

PERLND

GEN-INFO

```
<PLS ><-----Name----->NBLKS Unit-systems Printer ***  
# - # User t-series Engl Metr ***  
in out ***
```

```
10 C, Forest, Flat 1 1 1 1 27 0
```

END GEN-INFO

*** Section PWATER***

ACTIVITY

```
<PLS > ***** Active Sections *****  
# - # ATMP SNOW PWAT SED PST PWG PQAL MSTL PEST NITR PHOS TRAC ***  
10 0 0 1 0 0 0 0 0 0 0 0 0 0
```

END ACTIVITY

PRINT-INFO

```
<PLS > ***** Print-flags ***** PIVL PYR  
# - # ATMP SNOW PWAT SED PST PWG PQAL MSTL PEST NITR PHOS TRAC *****  
10 0 0 4 0 0 0 0 0 0 0 0 0 0 1 9
```

END PRINT-INFO

```

PWAT-PARM1
<PLS > PWATER variable monthly parameter value flags ***
# - # CSNO RTOP UZFG VCS VUZ VNN VIFW VIRC VLE INFC HWT ***
10 0 0 0 0 0 0 0 0 0 0 0
END PWAT-PARM1

PWAT-PARM2
<PLS > PWATER input info: Part 2 ***
# - # ***FOREST LZSN INFILT LSUR SLSUR KVARY AGWRC
10 0 4.5 0.08 400 0.05 0.5 0.996
END PWAT-PARM2

PWAT-PARM3
<PLS > PWATER input info: Part 3 ***
# - # ***PETMAX PETMIN INFEXP INFILD DEEPFR BASETP AGWETP
10 0 0 2 2 0 0 0
END PWAT-PARM3

PWAT-PARM4
<PLS > PWATER input info: Part 4 ***
# - # CEPSC UZSN NSUR INTFW IRC LZETP ***
10 0.2 0.5 0.35 6 0.5 0.7
END PWAT-PARM4

PWAT-STATE1
<PLS > *** Initial conditions at start of simulation
ran from 1990 to end of 1992 (pat 1-11-95) RUN 21 ***
# - # *** CEPS SURS UZS IFWS LZS AGWS GWVS
10 0 0 0 0 2.5 1 0
END PWAT-STATE1

END PERLND

IMPLND
GEN-INFO
<PLS ><-----Name-----> Unit-systems Printer ***
# - # User t-series Engl Metr ***
in out ***

END GEN-INFO
*** Section IWATER***

ACTIVITY
<PLS > ***** Active Sections *****
# - # ATMP SNOW IWAT SLD IWG IQAL ***
END ACTIVITY

PRINT-INFO
<ILS > ***** Print-flags ***** PIVL PYR
# - # ATMP SNOW IWAT SLD IWG IQAL *****
END PRINT-INFO

IWAT-PARM1
<PLS > IWATER variable monthly parameter value flags ***
# - # CSNO RTOP VRS VNN RTLI ***
END IWAT-PARM1

IWAT-PARM2
<PLS > IWATER input info: Part 2 ***
# - # *** LSUR SLSUR NSUR RETSC
END IWAT-PARM2

IWAT-PARM3
<PLS > IWATER input info: Part 3 ***
# - # ***PETMAX PETMIN
END IWAT-PARM3

IWAT-STATE1
<PLS > *** Initial conditions at start of simulation
# - # *** RETS SURS
END IWAT-STATE1

```

END IMPLND

SCHEMATIC

<-Source->	<Name> #	<--Area-->	<-factor-->	<-Target->	MBLK	***
Onsite Basin 2***					Tbl#	***
PERLND 10		0.06		COPY 501	12	
PERLND 10		0.06		COPY 501	13	

*****Routing*****
END SCHEMATIC

NETWORK

<-Volume->	<-Grp>	<-Member->	<--Mult-->	Tran	<-Target vols>	<-Grp>	<-Member->	***
<Name> #		<Name> #	#	<-factor-->strg	<Name> #	#	<Name> #	***
COPY 501	OUTPUT	MEAN	1 1	48.4	DISPLY 1	INPUT	TIMSER 1	

<-Volume->	<-Grp>	<-Member->	<--Mult-->	Tran	<-Target vols>	<-Grp>	<-Member->	***
<Name> #		<Name> #	#	<-factor-->strg	<Name> #	#	<Name> #	***

END NETWORK

RCHRES

GEN-INFO

RCHRES	Name	Nexits	Unit Systems	Printer	***
# - #	<----->	<---->	User T-series	Engl Metr LKFG	***
			in out		***

END GEN-INFO
*** Section RCHRES***

ACTIVITY

<PLS > ***** Active Sections *****

#	-	#	HYFG	ADFG	CNFG	HTFG	SDFG	GQFG	OXFG	NUFG	PKFG	PHFG	***
#	-	#	HYFG	ADFG	CNFG	HTFG	SDFG	GQFG	OXFG	NUFG	PKFG	PHFG	***

END ACTIVITY

PRINT-INFO

<PLS > ***** Print-flags ***** PIVL PYR

#	-	#	HYDR	ADCA	CONS	HEAT	SED	GQL	OXRX	NUTR	PLNK	PHCB	PIVL	PYR	*****
#	-	#	HYDR	ADCA	CONS	HEAT	SED	GQL	OXRX	NUTR	PLNK	PHCB	PIVL	PYR	*****

END PRINT-INFO

HYDR-PARM1

RCHRES	Flags for each HYDR Section	***	ODGTFG for each	FUNCT for each	***
# - #	VC A1 A2 A3	ODFVFG for each	***	ODGTFG for each	FUNCT for each
	FG FG FG FG	possible exit	***	possible exit	possible exit
	* * * *	* * * * *		* * * * *	***

END HYDR-PARM1

HYDR-PARM2

#	-	#	FTABNO	LEN	DELTH	STCOR	KS	DB50	***
<----->	<----->	<----->	<----->	<----->	<----->	<----->	<----->	<----->	***

END HYDR-PARM2

HYDR-INIT

RCHRES	Initial conditions for each HYDR section	***
# - #	*** VOL Initial value of COLIND Initial value of OUTDGT	***
	*** ac-ft for each possible exit for each possible exit	
<----->	<----->	*** <----->

END HYDR-INIT

END RCHRES

SPEC-ACTIONS

END SPEC-ACTIONS

FTABLES

END FTABLES

EXT SOURCES

<-Volume->	<Member>	SsysSgap	<--Mult-->	Tran	<-Target vols>	<-Grp>	<-Member->	***
<Name> #	<Name> #	tem	strg	<-factor-->strg	<Name> #	#	<Name> #	***
WDM 2	PREC	ENGL	1.2		PERLND 1	999	EXTNL	PREC
WDM 2	PREC	ENGL	1.2		IMPLND 1	999	EXTNL	PREC

```
WDM      1 EVAP      ENGL      0.76          PERLND   1 999 EXTNL  PETINP
WDM      1 EVAP      ENGL      0.76          IMPLND   1 999 EXTNL  PETINP
```

END EXT SOURCES

EXT TARGETS

```
<-Volume-> <-Grp> <-Member-><--Mult-->Tran <-Volume-> <Member> Tsys Tgap Amd ***
<Name>      #      <Name> # #<-factor->strg <Name>      # <Name>      tem strg strg***
COPY      501 OUTPUT MEAN      1 1      48.4      WDM      501 FLOW      ENGL      REPL
END EXT TARGETS
```

MASS-LINK

```
<Volume>   <-Grp> <-Member-><--Mult-->      <Target>      <-Grp> <-Member->***
<Name>     #      <Name> # #<-factor->      <Name>      <Name> # #***
  MASS-LINK      12
PERLND      PWATER SURO      0.083333      COPY      INPUT  MEAN
  END MASS-LINK      12
```

```
  MASS-LINK      13
PERLND      PWATER IFWO      0.083333      COPY      INPUT  MEAN
  END MASS-LINK      13
```

END MASS-LINK

END RUN

DRAFT

Mitigated UCI File

RUN

GLOBAL

```
WVHM4 model simulation
START      1948 10 01      END      2009 09 30
RUN INTERP OUTPUT LEVEL   3      0
RESUME     0 RUN         1
UNIT SYSTEM 1
```

FILES

```
<File> <Un#> <-----File Name----->***
<-ID->                                     ***
WDM      26      20220816 Lot 5_Roof Infiltration.wdm
MESSU    25      Mit20220816 Lot 5_Roof Infiltration.MES
          27      Mit20220816 Lot 5_Roof Infiltration.L61
          28      Mit20220816 Lot 5_Roof Infiltration.L62
          30      POC20220816 Lot 5_Roof Infiltration1.dat
```

END FILES

OPN SEQUENCE

```
INGRP          INDELT 00:15
  IMPLND        4
  RCHRES        1
  COPY          1
  COPY         501
  DISPLY        1
```

END INGRP

END OPN SEQUENCE

DISPLY

```
DISPLY-INF01
# - #<-----Title----->***TRAN PIVL DIG1 FIL1  PYR DIG2 FIL2 YRND
1      Infiltration Gallery #2      MAX      1      2      30      9
```

END DISPLY-INF01

END DISPLY

COPY

```
TIMESERIES
# - # NPT NMN ***
1      1      1
501    1      1
```

END TIMESERIES

END COPY

GENER

```
OPCODE
#      # OPCD ***
END OPCODE
PARM
#      #      K ***
```

END PARM

END GENER

PERLND

```
GEN-INFO
<PLS ><-----Name----->NBLKS Unit-systems Printer ***
# - # User t-series Engl Metr ***
                               in out      ***
```

END GEN-INFO

*** Section PWATER***

ACTIVITY

```
<PLS > ***** Active Sections *****
# - # ATMP SNOW PWAT SED PST PWG PQAL MSTL PEST NITR PHOS TRAC ***
```

END ACTIVITY

PRINT-INFO

```
<PLS > ***** Print-flags ***** PIVL PYR
# - # ATMP SNOW PWAT SED PST PWG PQAL MSTL PEST NITR PHOS TRAC *****
```

END PRINT-INFO

PWAT-PARM1

```

<PLS > PWATER variable monthly parameter value flags ***
# - # CSNO RTOP UZFG VCS VUZ VNN VIFW VIRG VLE INFC HWT ***
END PWAT-PARM1

PWAT-PARM2
<PLS > PWATER input info: Part 2 ***
# - # ***FOREST LZSN INFILT LSUR SLSUR KVARY AGWRC
END PWAT-PARM2

PWAT-PARM3
<PLS > PWATER input info: Part 3 ***
# - # ***PETMAX PETMIN INFEXP INFILD DEEPFR BASETP AGWETP
END PWAT-PARM3
PWAT-PARM4
<PLS > PWATER input info: Part 4 ***
# - # CEPSC UZSN NSUR INTFW IRC LZETP ***
END PWAT-PARM4

PWAT-STATE1
<PLS > *** Initial conditions at start of simulation
ran from 1990 to end of 1992 (pat 1-11-95) RUN 21 ***
# - # *** CEPS SURS UZS IFWS LZS AGWS GWVS
END PWAT-STATE1

END PERLND

IMPLND
GEN-INFO
<PLS ><-----Name-----> Unit-systems Printer ***
# - # User t-series Engl Metr ***
in out ***
4 ROOF TOPS/FLAT 1 1 1 27 0
END GEN-INFO
*** Section IWATER***

ACTIVITY
<PLS > ***** Active Sections *****
# - # ATMP SNOW IWAT SLD IWG IQAL ***
4 0 0 1 0 0 0
END ACTIVITY

PRINT-INFO
<ILS > ***** Print-flags ***** PIVL PYR
# - # ATMP SNOW IWAT SLD IWG IQAL *****
4 0 0 4 0 0 0 1 9
END PRINT-INFO

IWAT-PARM1
<PLS > IWATER variable monthly parameter value flags ***
# - # CSNO RTOP VRS VNN RTLI ***
4 0 0 0 0 0
END IWAT-PARM1

IWAT-PARM2
<PLS > IWATER input info: Part 2 ***
# - # *** LSUR SLSUR NSUR RETSC
4 400 0.01 0.1 0.1
END IWAT-PARM2

IWAT-PARM3
<PLS > IWATER input info: Part 3 ***
# - # ***PETMAX PETMIN
4 0 0
END IWAT-PARM3

IWAT-STATE1
<PLS > *** Initial conditions at start of simulation
# - # *** RETS SURS
4 0 0
END IWAT-STATE1

```

END IMPLND

SCHEMATIC

<-Source->	<--Area-->	<-Target->	MBLK	***
<Name> #	<-factor->	<Name> #	Tbl#	***
Onsite Basin 2***				
IMPLND 4	0.06	RCHRES 1	5	

*****Routing*****

IMPLND 4	0.06	COPY 1	15
RCHRES 1	1	COPY 501	17

END SCHEMATIC

NETWORK

<-Volume->	<-Grp>	<-Member->	<--Mult-->	Tran	<-Target vols>	<-Grp>	<-Member->	***
<Name> #		<Name> #	#	<-factor->	strg	<Name> #	#	<Name> # #
COPY 501	OUTPUT	MEAN	1	1	48.4	DISPLY	1	INPUT TIMSER 1

<-Volume->	<-Grp>	<-Member->	<--Mult-->	Tran	<-Target vols>	<-Grp>	<-Member->	***
<Name> #		<Name> #	#	<-factor->	strg	<Name> #	#	<Name> # #

END NETWORK

RCHRES

GEN-INFO

RCHRES	Name	Nexits	Unit	Systems	Printer	***
# - #	<----->	<----->	User	T-series	Engl Metr LKFG	***
			in	out		***
1	Infiltration Gal-016	2	1	1 1	28 0 1	

END GEN-INFO

*** Section RCHRES***

ACTIVITY

<PLS >	***** Active Sections *****										
# - #	HYFG	ADFG	CNFG	HTFG	SDFG	GQFG	OXFG	NUFG	PKFG	PHFG	***
1	1	0	0	0	0	0	0	0	0	0	

END ACTIVITY

PRINT-INFO

<PLS >	***** Print-flags *****										PIVL	PYR	***
# - #	HYDR	ADCA	CONS	HEAT	SED	GQL	OXRX	NUTR	PLNK	PHCB	PIVL	PYR	*****
1	4	0	0	0	0	0	0	0	0	0	1	9	

END PRINT-INFO

HYDR-PARM1

RCHRES	Flags for each HYDR Section	***	ODGTFG for each	FUNCT for each	***
# - #	VC A1 A2 A3	ODFVFG for each	*** possible exit	*** possible exit	possible exit
	FG FG FG FG	* * * * *	* * * * *	* * * * *	***
1	0 1 0 0	4 5 0 0 0	0 0 0 0 0	2 2 2 2 2	

END HYDR-PARM1

HYDR-PARM2

# - #	FTABNO	LEN	DELTH	STCOR	KS	DB50	***
<----->	<----->	<----->	<----->	<----->	<----->	<----->	***
1	1	0.01	0.0	0.0	0.5	0.0	

END HYDR-PARM2

HYDR-INIT

RCHRES	Initial conditions for each HYDR section	***
# - #	*** VOL	Initial value of COLIND
	*** ac-ft	for each possible exit
		Initial value of OUTDGT
		for each possible exit
1	0	4.0 5.0 0.0 0.0 0.0

END HYDR-INIT

END RCHRES

SPEC-ACTIONS

END SPEC-ACTIONS

FTABLES

FTABLE 1
92 5

Depth (ft)	Area (acres)	Volume (acre-ft)	Outflow1 (cfs)	Outflow2 (cfs)	Velocity (ft/sec)	Travel Time*** (Minutes)***
0.000000	0.014463	0.000000	0.000000	0.000000		
0.027778	0.014463	0.000141	0.000000	0.004375		
0.055556	0.014463	0.000281	0.000000	0.004375		
0.083333	0.014463	0.000422	0.000000	0.004375		
0.111111	0.014463	0.000562	0.000000	0.004375		
0.138889	0.014463	0.000703	0.000000	0.004375		
0.166667	0.014463	0.000844	0.000000	0.004375		
0.194444	0.014463	0.000984	0.000000	0.004375		
0.222222	0.014463	0.001125	0.000000	0.004375		
0.250000	0.014463	0.001266	0.000000	0.004375		
0.277778	0.014463	0.001406	0.000000	0.004375		
0.305556	0.014463	0.001547	0.000000	0.004375		
0.333333	0.014463	0.001687	0.000000	0.004375		
0.361111	0.014463	0.001828	0.000000	0.004375		
0.388889	0.014463	0.001969	0.000000	0.004375		
0.416667	0.014463	0.002109	0.000000	0.004375		
0.444444	0.014463	0.002250	0.000000	0.004375		
0.472222	0.014463	0.002390	0.000000	0.004375		
0.500000	0.014463	0.002531	0.000000	0.004375		
0.527778	0.014463	0.002672	0.000000	0.004375		
0.555556	0.014463	0.002812	0.000000	0.004375		
0.583333	0.014463	0.002953	0.000000	0.004375		
0.611111	0.014463	0.003093	0.000000	0.004375		
0.638889	0.014463	0.003234	0.000000	0.004375		
0.666667	0.014463	0.003375	0.000000	0.004375		
0.694444	0.014463	0.003515	0.000000	0.004375		
0.722222	0.014463	0.003656	0.000000	0.004375		
0.750000	0.014463	0.003797	0.000000	0.004375		
0.777778	0.014463	0.003937	0.000000	0.004375		
0.805556	0.014463	0.004078	0.000000	0.004375		
0.833333	0.014463	0.004218	0.000000	0.004375		
0.861111	0.014463	0.004359	0.000000	0.004375		
0.888889	0.014463	0.004500	0.000000	0.004375		
0.916667	0.014463	0.004640	0.000000	0.004375		
0.944444	0.014463	0.004781	0.000000	0.004375		
0.972222	0.014463	0.004921	0.000000	0.004375		
1.000000	0.014463	0.005062	0.000000	0.004375		
1.027778	0.014463	0.005203	0.000000	0.004375		
1.055556	0.014463	0.005343	0.000000	0.004375		
1.083333	0.014463	0.005484	0.000000	0.004375		
1.111111	0.014463	0.005625	0.000000	0.004375		
1.138889	0.014463	0.005765	0.000000	0.004375		
1.166667	0.014463	0.005906	0.000000	0.004375		
1.194444	0.014463	0.006046	0.000000	0.004375		
1.222222	0.014463	0.006187	0.000000	0.004375		
1.250000	0.014463	0.006328	0.000000	0.004375		
1.277778	0.014463	0.006468	0.000000	0.004375		
1.305556	0.014463	0.006609	0.000000	0.004375		
1.333333	0.014463	0.006749	0.000000	0.004375		
1.361111	0.014463	0.006890	0.000000	0.004375		
1.388889	0.014463	0.007031	0.000000	0.004375		
1.416667	0.014463	0.007171	0.000000	0.004375		
1.444444	0.014463	0.007312	0.000000	0.004375		
1.472222	0.014463	0.007452	0.000000	0.004375		
1.500000	0.014463	0.007593	0.000000	0.004375		
1.527778	0.014463	0.007734	0.000000	0.004375		
1.555556	0.014463	0.007874	0.000000	0.004375		
1.583333	0.014463	0.008015	0.000000	0.004375		
1.611111	0.014463	0.008156	0.000000	0.004375		
1.638889	0.014463	0.008296	0.000000	0.004375		
1.666667	0.014463	0.008437	0.000000	0.004375		
1.694444	0.014463	0.008577	0.000000	0.004375		
1.722222	0.014463	0.008718	0.000000	0.004375		
1.750000	0.014463	0.008859	0.000000	0.004375		
1.777778	0.014463	0.008999	0.000000	0.004375		

1.805556	0.014463	0.009140	0.000000	0.004375
1.833333	0.014463	0.009280	0.000000	0.004375
1.861111	0.014463	0.009421	0.000000	0.004375
1.888889	0.014463	0.009562	0.000000	0.004375
1.916667	0.014463	0.009702	0.000000	0.004375
1.944444	0.014463	0.009843	0.000000	0.004375
1.972222	0.014463	0.009984	0.000000	0.004375
2.000000	0.014463	0.010124	0.000000	0.004375
2.027778	0.014463	0.010265	0.000000	0.004375
2.055556	0.014463	0.010405	0.000000	0.004375
2.083333	0.014463	0.010546	0.000000	0.004375
2.111111	0.014463	0.010687	0.000000	0.004375
2.138889	0.014463	0.010827	0.000000	0.004375
2.166667	0.014463	0.010968	0.000000	0.004375
2.194444	0.014463	0.011108	0.000000	0.004375
2.222222	0.014463	0.011249	0.000000	0.004375
2.250000	0.014463	0.011390	0.000000	0.004375
2.277778	0.014463	0.011530	0.000000	0.004375
2.305556	0.014463	0.011671	0.000000	0.004375
2.333333	0.014463	0.011811	0.000000	0.004375
2.361111	0.014463	0.011952	0.000000	0.004375
2.388889	0.014463	0.012093	0.000000	0.004375
2.416667	0.014463	0.012233	0.022834	0.004375
2.444444	0.014463	0.012374	0.099321	0.004375
2.472222	0.014463	0.012515	0.205391	0.004375
2.500000	0.014463	0.012655	0.333520	0.004375
2.527778	0.014463	0.013057	0.478890	0.004375

END FTABLE 1

END FTABLES

EXT SOURCES

<-Volume->	<Member>	SsysSgap	<--Mult-->	Tran	<-Target vols>	<-Grp>	<-Member->	***	
<Name>	#	<Name>	#	tem strg	<-factor->	strg	<Name>	# #	***
WDM	2	PREC	ENGL	1.2	PERLND	1 999	EXTNL	PREC	
WDM	2	PREC	ENGL	1.2	IMPLND	1 999	EXTNL	PREC	
WDM	1	EVAP	ENGL	0.76	PERLND	1 999	EXTNL	PETINP	
WDM	1	EVAP	ENGL	0.76	IMPLND	1 999	EXTNL	PETINP	

END EXT SOURCES

EXT TARGETS

<-Volume->	<-Grp>	<-Member->	<--Mult-->	Tran	<-Volume->	<Member>	Tsys	Tgap	Amd	***
<Name>	#	<Name>	#	#<-factor->	strg	<Name>	#	<Name>	tem strg	strg***
RCHRES	1	HYDR	RO	1 1	1	WDM	1004	FLOW	ENGL	REPL
RCHRES	1	HYDR	O	1 1	1	WDM	1005	FLOW	ENGL	REPL
RCHRES	1	HYDR	O	2 1	1	WDM	1006	FLOW	ENGL	REPL
RCHRES	1	HYDR	STAGE	1 1	1	WDM	1007	STAG	ENGL	REPL
COPY	1	OUTPUT	MEAN	1 1	48.4	WDM	701	FLOW	ENGL	REPL
COPY	501	OUTPUT	MEAN	1 1	48.4	WDM	801	FLOW	ENGL	REPL

END EXT TARGETS

MASS-LINK

<Volume>	<-Grp>	<-Member->	<--Mult-->	<Target>	<-Grp>	<-Member->	***	
<Name>	#	<Name>	#	<-factor->	<Name>	#	#	***
MASS-LINK			5					
IMPLND	IWATER	SURO		0.083333	RCHRES	INFLOW	IVOL	
END MASS-LINK			5					
MASS-LINK			15					
IMPLND	IWATER	SURO		0.083333	COPY	INPUT	MEAN	
END MASS-LINK			15					
MASS-LINK			17					
RCHRES	OFLOW	OVOL	1		COPY	INPUT	MEAN	
END MASS-LINK			17					

END MASS-LINK

END RUN

DRAFT

DRAFT

DRAFT

Disclaimer

Legal Notice

This program and accompanying documentation are provided 'as-is' without warranty of any kind. The entire risk regarding the performance and results of this program is assumed by End User. Clear Creek Solutions Inc. and the governmental licensee or sublicensees disclaim all warranties, either expressed or implied, including but not limited to implied warranties of program and accompanying documentation. In no event shall Clear Creek Solutions Inc. be liable for any damages whatsoever (including without limitation to damages for loss of business profits, loss of business information, business interruption, and the like) arising out of the use of, or inability to use this program even if Clear Creek Solutions Inc. or their authorized representatives have been advised of the possibility of such damages. Software Copyright © by : Clear Creek Solutions, Inc. 2005-2022; All Rights Reserved.

Clear Creek Solutions, Inc.
6200 Capitol Blvd. Ste F
Olympia, WA. 98501
Toll Free 1(866)943-0304
Local (360)943-0304

www.clearcreeksolutions.com

DRAFT

PEAK FLOW ANALYSIS - WWHM OUTPUT

Predeveloped Basins & Peak Flows

Onsite Basin Predeveloped

Subbasin Name:

Flows To : Surface Interflow Groundwater

Area in Basin Show Only Selected

Available Pervious		Acres	Available Impervious		Acres
<input type="checkbox"/>	A/B, Forest, Flat	0	<input checked="" type="checkbox"/>	ROADS/FLAT	0
<input type="checkbox"/>	A/B, Forest, Mod	0	<input type="checkbox"/>	ROADS/MOD	0
<input type="checkbox"/>	A/B, Forest, Steep	0	<input type="checkbox"/>	ROADS/STEEP	0
<input type="checkbox"/>	A/B, Pasture, Flat	0	<input checked="" type="checkbox"/>	ROOF TOPS/FLAT	0
<input type="checkbox"/>	A/B, Pasture, Mod	0	<input checked="" type="checkbox"/>	DRIVEWAYS/FLAT	0
<input type="checkbox"/>	A/B, Pasture, Steep	0	<input type="checkbox"/>	DRIVEWAYS/MOD	0
<input type="checkbox"/>	A/B, Lawn, Flat	0	<input type="checkbox"/>	DRIVEWAYS/STEEP	0
<input type="checkbox"/>	A/B, Lawn, Mod	0	<input checked="" type="checkbox"/>	SIDEWALKS/FLAT	0
<input type="checkbox"/>	A/B, Lawn, Steep	0	<input type="checkbox"/>	SIDEWALKS/MOD	0
<input checked="" type="checkbox"/>	C, Forest, Flat	1.24	<input type="checkbox"/>	SIDEWALKS/STEEP	0
<input type="checkbox"/>	C, Forest, Mod	0	<input type="checkbox"/>	PARKING/FLAT	0
<input type="checkbox"/>	C, Forest, Steep	0	<input type="checkbox"/>	PARKING/MOD	0
<input checked="" type="checkbox"/>	C, Pasture, Flat	0	<input type="checkbox"/>	PARKING/STEEP	0
<input type="checkbox"/>	C, Pasture, Mod	0	<input type="checkbox"/>	POND	0
<input type="checkbox"/>	C, Pasture, Steep	0	<input type="checkbox"/>	Porous Pavement	0
<input type="checkbox"/>	C, Lawn, Flat	0	<input type="checkbox"/>	Porous Pavement	0
<input type="checkbox"/>	C, Lawn, Mod	0	<input type="checkbox"/>	DRIVEWAYS/FLAT	0
<input type="checkbox"/>	C, Lawn, Steep	0	<input checked="" type="checkbox"/>	SIDEWALKS/FLAT	0
<input type="checkbox"/>	SAT, Forest, Flat	0			
<input type="checkbox"/>	SAT, Forest, Mod	0			
<input type="checkbox"/>	SAT, Forest, Steep	0			

Pervious Total Acres

Impervious Total Acres

Basin Total Acres

Select By:

Frontage Predeveloped X

Subbasin Name:

Flows To : Surface Interflow Groundwater

Area in Basin Show Only Selected

Available Pervious		Acres	Available Impervious		Acres
<input type="checkbox"/> A/B, Forest, Flat		0	<input checked="" type="checkbox"/> ROADS/FLAT		0.025
<input type="checkbox"/> A/B, Forest, Mod		0	<input type="checkbox"/> ROADS/MOD		0
<input type="checkbox"/> A/B, Forest, Steep		0	<input type="checkbox"/> ROADS/STEEP		0
<input type="checkbox"/> A/B, Pasture, Flat		0	<input checked="" type="checkbox"/> ROOF TOPS/FLAT		0
<input type="checkbox"/> A/B, Pasture, Mod		0	<input checked="" type="checkbox"/> DRIVEWAYS/FLAT		0
<input type="checkbox"/> A/B, Pasture, Steep		0	<input type="checkbox"/> DRIVEWAYS/MOD		0
<input type="checkbox"/> A/B, Lawn, Flat		0	<input type="checkbox"/> DRIVEWAYS/STEEP		0
<input type="checkbox"/> A/B, Lawn, Mod		0	<input checked="" type="checkbox"/> SIDEWALKS/FLAT		0
<input type="checkbox"/> A/B, Lawn, Steep		0	<input type="checkbox"/> SIDEWALKS/MOD		0
<input checked="" type="checkbox"/> C, Forest, Flat		0.02	<input type="checkbox"/> SIDEWALKS/STEEP		0
<input type="checkbox"/> C, Forest, Mod		0	<input type="checkbox"/> PARKING/FLAT		0
<input type="checkbox"/> C, Forest, Steep		0	<input type="checkbox"/> PARKING/MOD		0
<input checked="" type="checkbox"/> C, Pasture, Flat		0	<input type="checkbox"/> PARKING/STEEP		0
<input type="checkbox"/> C, Pasture, Mod		0	<input type="checkbox"/> POND		0
<input type="checkbox"/> C, Pasture, Steep		0	<input type="checkbox"/> Porous Pavement		0
<input type="checkbox"/> C, Lawn, Flat		0	<input type="checkbox"/> Porous Pavement		0
<input type="checkbox"/> C, Lawn, Mod		0	<input type="checkbox"/> DRIVEWAYS/FLAT		0
<input type="checkbox"/> C, Lawn, Steep		0	<input checked="" type="checkbox"/> SIDEWALKS/FLAT		0
<input type="checkbox"/> SAT, Forest, Flat		0			
<input type="checkbox"/> SAT, Forest, Mod		0			
<input type="checkbox"/> SAT, Forest, Steep		0			

Pervious Total	<input type="text" value="0.02"/>	Acres
Impervious Total	<input type="text" value="0.025"/>	Acres
Basin Total	<input type="text" value="0.045"/>	Acres

Select By:

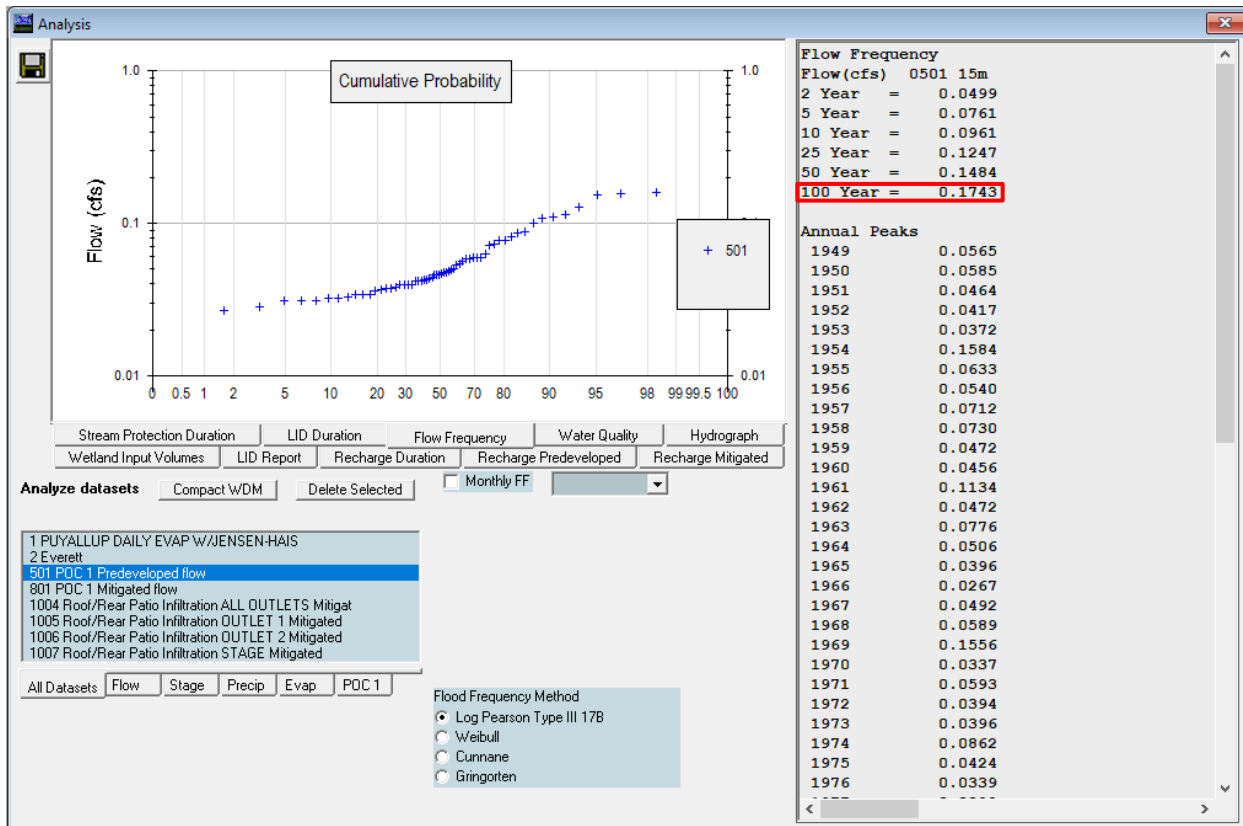

Developed Basins & Peak Flows

Frontage Basin (Developed) Mitigated
X

Subbasin Name: Designate as Bypass for PDC:

Surface
Interflow
Groundwater

Flows To :

Area in Basin

	Available Pervious	Acres
▲	<input type="checkbox"/> A/B, Forest, Flat	0
	<input type="checkbox"/> A/B, Forest, Mod	0
	<input type="checkbox"/> A/B, Forest, Steep	0
	<input type="checkbox"/> A/B, Pasture, Flat	0
	<input type="checkbox"/> A/B, Pasture, Mod	0
	<input type="checkbox"/> A/B, Pasture, Steep	0
	<input type="checkbox"/> A/B, Lawn, Flat	0
	<input type="checkbox"/> A/B, Lawn, Mod	0
	<input type="checkbox"/> A/B, Lawn, Steep	0
	<input checked="" type="checkbox"/> C, Forest, Flat	0
	<input type="checkbox"/> C, Forest, Mod	0
	<input type="checkbox"/> C, Forest, Steep	0
	<input checked="" type="checkbox"/> C, Pasture, Flat	.005
	<input type="checkbox"/> C, Pasture, Mod	0
	<input type="checkbox"/> C, Pasture, Steep	0
	<input type="checkbox"/> C, Lawn, Flat	0
	<input type="checkbox"/> C, Lawn, Mod	0
	<input type="checkbox"/> C, Lawn, Steep	0
	<input type="checkbox"/> SAT, Forest, Flat	0
	<input type="checkbox"/> SAT, Forest, Mod	0
▼	<input type="checkbox"/> SAT, Forest, Steep	0

Show Only Selected

	Available Impervious	Acres
✓	ROADS/FLAT	.02
☐	ROADS/MOD	0
☐	ROADS/STEEP	0
✓	ROOF TOPS/FLAT	0
✓	DRIVEWAYS/FLAT	0
☐	DRIVEWAYS/MOD	0
☐	DRIVEWAYS/STEEP	0
✓	SIDEWALKS/FLAT	.02
☐	SIDEWALKS/MOD	0
☐	SIDEWALKS/STEEP	0
☐	PARKING/FLAT	0
☐	PARKING/MOD	0
☐	PARKING/STEEP	0
☐	POND	0
☐	Porous Pavement	0
☐	Porous Pavement	0
☐	DRIVEWAYS/FLAT	0
✓	SIDEWALKS/FLAT	0

Pervious Total Acres

Impervious Total Acres

Basin Total Acres

Select By:

Onsite Basin 1 Mitigated

Subbasin Name: Designate as Bypass for POC:

Flows To :

Area in Basin Show Only Selected

Available Pervious		Acres	Available Impervious		Acres
<input type="checkbox"/>	A/B, Forest, Flat	0	<input checked="" type="checkbox"/>	ROADS/FLAT	.19
<input type="checkbox"/>	A/B, Forest, Mod	0	<input type="checkbox"/>	ROADS/MOD	0
<input type="checkbox"/>	A/B, Forest, Steep	0	<input type="checkbox"/>	ROADS/STEEP	0
<input type="checkbox"/>	A/B, Pasture, Flat	0	<input checked="" type="checkbox"/>	ROOF TOPS/FLAT	.24
<input type="checkbox"/>	A/B, Pasture, Mod	0	<input checked="" type="checkbox"/>	DRIVEWAYS/FLAT	.03
<input type="checkbox"/>	A/B, Pasture, Steep	0	<input type="checkbox"/>	DRIVEWAYS/MOD	0
<input type="checkbox"/>	A/B, Lawn, Flat	0	<input type="checkbox"/>	DRIVEWAYS/STEEP	0
<input type="checkbox"/>	A/B, Lawn, Mod	0	<input checked="" type="checkbox"/>	SIDEWALKS/FLAT	.06
<input type="checkbox"/>	A/B, Lawn, Steep	0	<input type="checkbox"/>	SIDEWALKS/MOD	0
<input checked="" type="checkbox"/>	C, Forest, Flat	0	<input type="checkbox"/>	SIDEWALKS/STEEP	0
<input type="checkbox"/>	C, Forest, Mod	0	<input type="checkbox"/>	PARKING/FLAT	0
<input type="checkbox"/>	C, Forest, Steep	0	<input type="checkbox"/>	PARKING/MOD	0
<input checked="" type="checkbox"/>	C, Pasture, Flat	.66	<input type="checkbox"/>	PARKING/STEEP	0
<input type="checkbox"/>	C, Pasture, Mod	0	<input type="checkbox"/>	POND	0
<input type="checkbox"/>	C, Pasture, Steep	0	<input type="checkbox"/>	Porous Pavement	0
<input type="checkbox"/>	C, Lawn, Flat	0	<input type="checkbox"/>	Porous Pavement	0
<input type="checkbox"/>	C, Lawn, Mod	0	<input type="checkbox"/>	DRIVEWAYS/FLAT	0
<input type="checkbox"/>	C, Lawn, Steep	0	<input checked="" type="checkbox"/>	SIDEWALKS/FLAT	0
<input type="checkbox"/>	SAT, Forest, Flat	0			
<input type="checkbox"/>	SAT, Forest, Mod	0			
<input type="checkbox"/>	SAT, Forest, Steep	0			

Pervious Total Acres

Impervious Total Acres

Basin Total Acres

Select By:

Onsite Basin 2 Mitigated

Subbasin Name: Designate as Bypass for POC:

Flows To :

Area in Basin Show Only Selected

Available Pervious		Acres	Available Impervious		Acres
<input type="checkbox"/>	A/B, Forest, Flat	0	<input checked="" type="checkbox"/>	ROADS/FLAT	0
<input type="checkbox"/>	A/B, Forest, Mod	0	<input type="checkbox"/>	ROADS/MOD	0
<input type="checkbox"/>	A/B, Forest, Steep	0	<input type="checkbox"/>	ROADS/STEEP	0
<input type="checkbox"/>	A/B, Pasture, Flat	0	<input checked="" type="checkbox"/>	ROOF TOPS/FLAT	.06
<input type="checkbox"/>	A/B, Pasture, Mod	0	<input checked="" type="checkbox"/>	DRIVEWAYS/FLAT	0
<input type="checkbox"/>	A/B, Pasture, Steep	0	<input type="checkbox"/>	DRIVEWAYS/MOD	0
<input type="checkbox"/>	A/B, Lawn, Flat	0	<input type="checkbox"/>	DRIVEWAYS/STEEP	0
<input type="checkbox"/>	A/B, Lawn, Mod	0	<input checked="" type="checkbox"/>	SIDEWALKS/FLAT	0
<input type="checkbox"/>	A/B, Lawn, Steep	0	<input type="checkbox"/>	SIDEWALKS/MOD	0
<input checked="" type="checkbox"/>	C, Forest, Flat	0	<input type="checkbox"/>	SIDEWALKS/STEEP	0
<input type="checkbox"/>	C, Forest, Mod	0	<input type="checkbox"/>	PARKING/FLAT	0
<input type="checkbox"/>	C, Forest, Steep	0	<input type="checkbox"/>	PARKING/MOD	0
<input checked="" type="checkbox"/>	C, Pasture, Flat	0	<input type="checkbox"/>	PARKING/STEEP	0
<input type="checkbox"/>	C, Pasture, Mod	0	<input type="checkbox"/>	POND	0
<input type="checkbox"/>	C, Pasture, Steep	0	<input type="checkbox"/>	Porous Pavement	0
<input type="checkbox"/>	C, Lawn, Flat	0	<input type="checkbox"/>	Porous Pavement	0
<input type="checkbox"/>	C, Lawn, Mod	0	<input type="checkbox"/>	DRIVEWAYS/FLAT	0
<input type="checkbox"/>	C, Lawn, Steep	0	<input checked="" type="checkbox"/>	SIDEWALKS/FLAT	0
<input type="checkbox"/>	SAT, Forest, Flat	0			
<input type="checkbox"/>	SAT, Forest, Mod	0			
<input type="checkbox"/>	SAT, Forest, Steep	0			

Pervious Total Acres

Impervious Total Acres

Basin Total Acres

Select By:

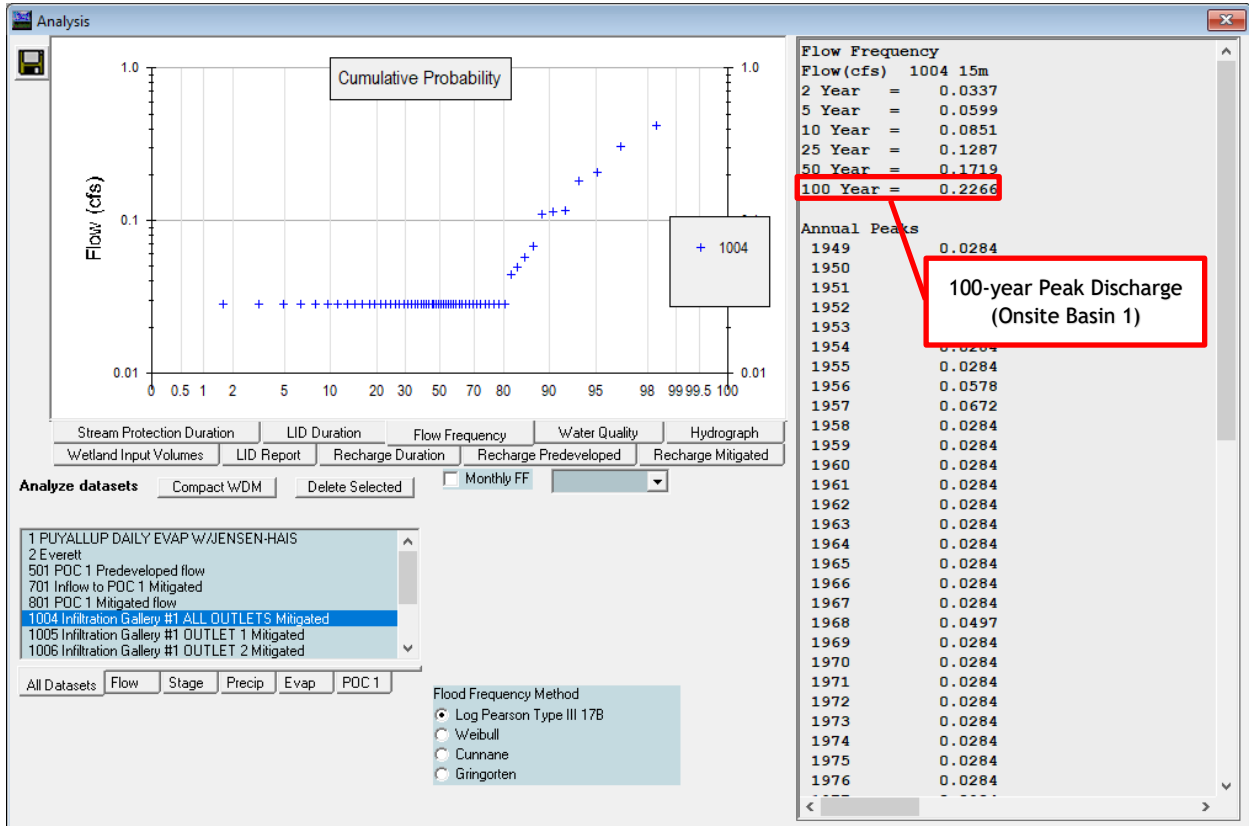
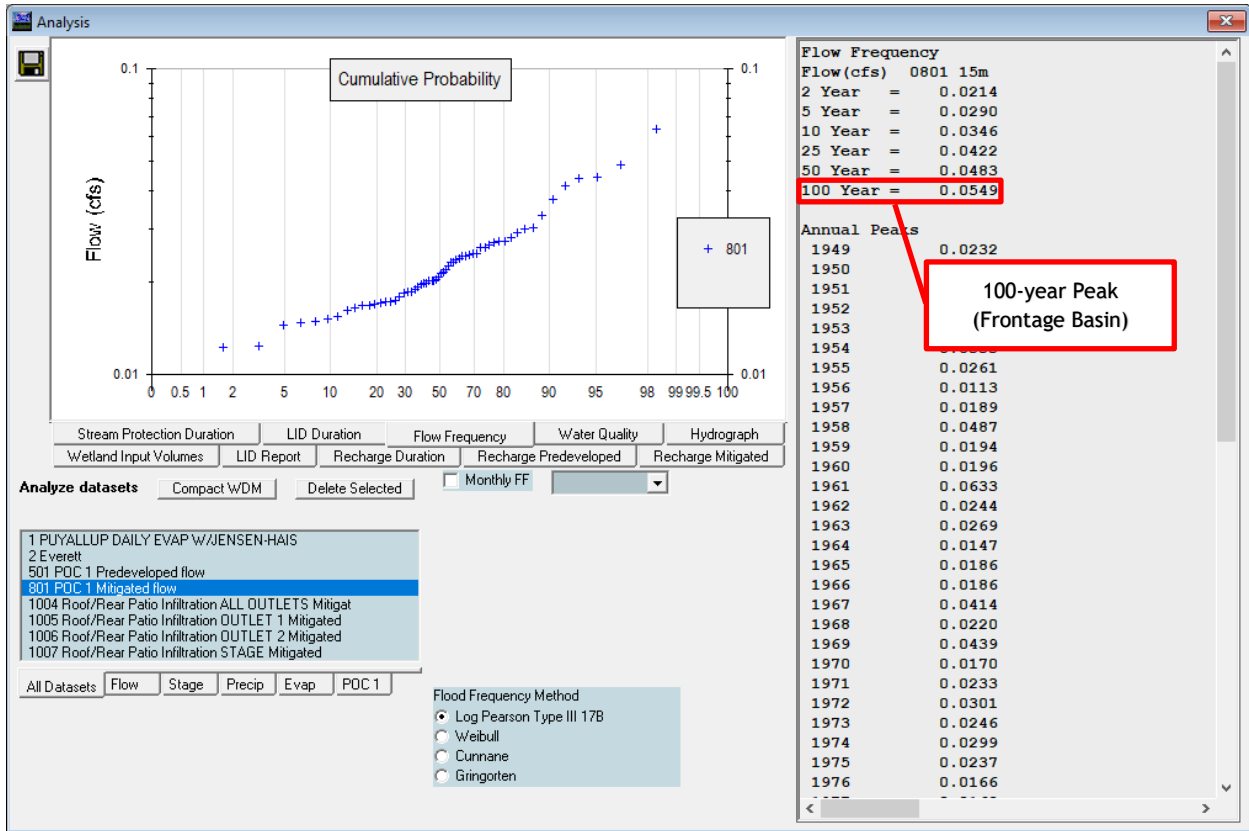

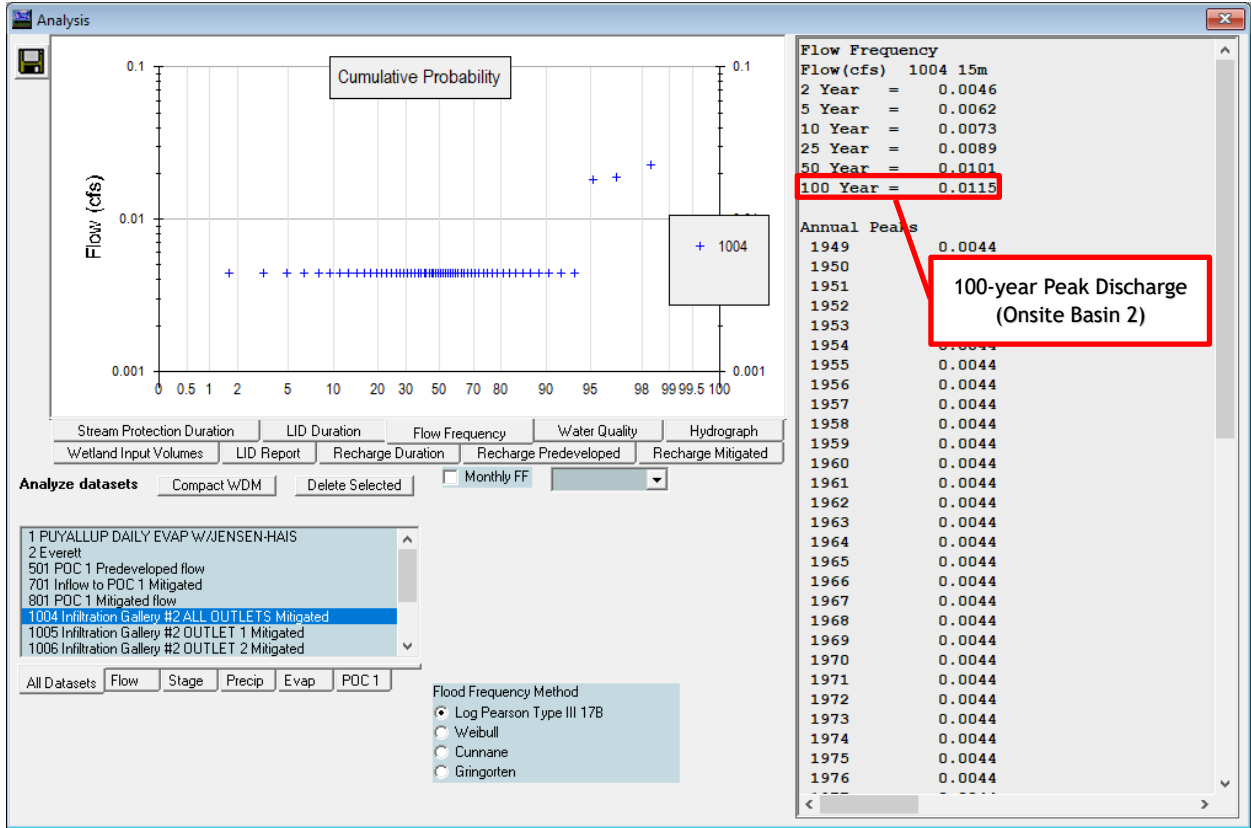

SECTION 5.0: CONVEYANCE ANALYSIS AND DESIGN

Conveyance Capacity Analysis

The proposed stormwater system is comprised of the primary flow intake(s), infiltration volumes, and overflow/discharge lines. Catch basins have been located such that each section of storm drainage pipe can adequately convey associated tributary area flows. Detailed conveyance capacity analysis is not required at this stage of the project. However, a preliminary Manning's Analysis has been performed to verify capacity of the infiltration gallery overflow/discharge lines.

Infiltration Gallery Overflow/Discharge Line

Preliminary conveyance capacity calculations for the Infiltration Gallery 1 and 2 overflow/discharge lines were performed using Manning's Equation on the shallowest anticipated pipe slope to determine pipe capacity in the 100-year storm event. A copy of this calculation, which demonstrates compliance in the 100-year storm event, can be found in Appendix 5. A summary analysis for both discharge lines is as follows:

Infiltration Gallery 1 Overflow/Discharge:

Maximum Flow Rate:	0.86 cfs (100-Year Unmitigated - WWHM2012)
Pipe Diameter:	8"
Minimum Slope:	0.70%
Maximum Pipe Flow Rate:	1.01 cfs
Evaluation:	System Adequate

Infiltration Gallery 2 Overflow/Discharge:

Maximum Flow Rate:	0.08 cfs (100-Year Unmitigated - WWHM2012)
Pipe Diameter:	6"
Minimum Slope:	0.50%
Maximum Pipe Flow Rate:	0.40 cfs
Evaluation:	System Adequate

Appendix 5: Conveyance Data and Analysis

1. Manning's Analysis: Infiltration Gallery 1 Overflow
2. Manning's Analysis: Infiltration Gallery 2 Overflow

Open Channel Flow Calculator For Circular Pipes	Land Development Consultants, Inc.	
	14201 NE 200th St. Ste. 100 Woodinville, WA 98072	Tel: (425) 806-1869 Fax: (425) 482-2893

Project Name: Stack Short Plat
 Description: Gallery 2 Overflow/Discharge

Project No.: C22-144
 Date: 9/9/2022
 Calc. By: SJW

Pipe Diameter (D) = 6 in
 Pipe Slope (S) = 0.50 %
 Flow Depth (y) = 0.50 ft
Flowrate (Q) = 0.40 cfs
 Mannings Coeff. (n) = 0.013
 Theta Angle (θ) = 6.28 rad
 Wetted Area (A) = 0.20 ft²
 Wet. Perimeter (P) = 1.57 ft
 Hydraulic Radius (R) = 0.13 ft
 Top Width (T) = 0.00 ft
 Flow Velocity = 2.03 fps

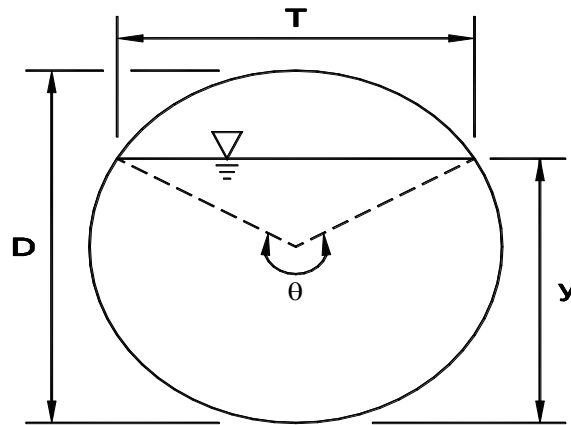

Formulas:

Theta Angle (θ): If $y \geq r$: $\theta = 2\pi - 2a \cos\left(\frac{y-r}{r}\right)$ where: r = Pipe Radius

If $y \leq r$: $\theta = 2a \cos\left(\frac{r-y}{r}\right)$ where: r = Pipe Radius

Wetted Area (A): $A = \frac{1}{8}(\theta - \sin \theta)d^2$

Wetted Perimeter (P): $P = \frac{1}{2}\theta d$

Hydraulic Radius (R): $R = \frac{A}{P}$

Top Width (T): $T = \sin\left(\frac{\theta}{2}\right)d$

SECTION 6.0: OPERATIONS AND MAINTENANCE MANUAL

The proposed storm drainage system consists of buried pipes, catch basins, infiltration facilities, and a StormFilter structure. These facilities will require periodic maintenance and inspection. Inspection and maintenance procedures are contained on the following pages.

Table V-A.2: Maintenance Standards - Infiltration

Maintenance Component	Defect	Conditions When Maintenance Is Needed	Results Expected When Maintenance Is Performed
General	Trash & Debris	See Table V-A. 1: Maintenance Standards - Detention Ponds	See Table V-A. 1: Maintenance Standards - Detention Ponds
	Poisonous/Noxious Vegetation	See Table V-A. 1: Maintenance Standards - Detention Ponds	See Table V-A. 1: Maintenance Standards - Detention Ponds
	Contaminants and Pollution	See Table V-A. 1: Maintenance Standards - Detention Ponds	See Table V-A. 1: Maintenance Standards - Detention Ponds
	Rodent Holes	See Table V-A. 1: Maintenance Standards - Detention Ponds	See Table V-A. 1: Maintenance Standards - Detention Ponds
Storage Area	Sediment	Water ponding in infiltration pond after rainfall ceases and appropriate time allowed for infiltration. Treatment basins should infiltrate Water Quality Design Storm Volume within 48 hours, and empty within 24 hours after cessation of most rain events.	Sediment is removed and/or facility is cleaned so that infiltration system works according to design.

Table V-A.2: Maintenance Standards - Infiltration (continued)

Maintenance Component	Defect	Conditions When Maintenance Is Needed	Results Expected When Maintenance Is Performed
		(A percolation test pit or test of facility indicates facility is only working at 90% of its designed capabilities. Test every 2 to 5 years. If two inches or more sediment is present, remove).	
Filter Bags (if applicable)	Filled with Sediment and Debris	Sediment and debris fill bag more than 1/2 full.	Filter bag is replaced or system is redesigned.
Rock Filters	Sediment and Debris	By visual inspection, little or no water flows through filter during heavy rain storms.	Gravel in rock filter is replaced.
Side Slopes of Pond	Erosion	See Table V-A.1: Maintenance Standards - Detention Ponds	See Table V-A.1: Maintenance Standards - Detention Ponds
Emergency Overflow Spillway and Berms over 4 feet in height.	Tree Growth	See Table V-A.1: Maintenance Standards - Detention Ponds	See Table V-A.1: Maintenance Standards - Detention Ponds
	Piping	See Table V-A.1: Maintenance Standards - Detention Ponds	See Table V-A.1: Maintenance Standards - Detention Ponds
Emergency Overflow Spillway	Rock Missing	See Table V-A.1: Maintenance Standards - Detention Ponds	See Table V-A.1: Maintenance Standards - Detention Ponds
	Erosion	See Table V-A.1: Maintenance Standards - Detention Ponds	See Table V-A.1: Maintenance Standards - Detention Ponds
Pre-settling Ponds and Vaults	Facility or sump filled with Sediment and/or debris	6" or designed sediment trap depth of sediment.	Sediment is removed.

Table V-A.5: Maintenance Standards - Catch Basins

Maintenance Component	Defect	Conditions When Maintenance is Needed	Results Expected When Maintenance is performed
General	Trash & Debris	Trash or debris which is located immediately in front of the catch basin opening or is blocking inletting capacity of the basin by more than 10%. Trash or debris (in the basin) that exceeds 60 percent of the sump depth as measured from the bottom of basin to invert of the lowest pipe into or out of the basin, but in no case less than a minimum of six inches clearance from the debris surface to the invert of the lowest pipe. Trash or debris in any inlet or outlet pipe blocking more than 1/3 of its height. Dead animals or vegetation that could generate odors that could cause complaints or dangerous gases (e.g., methane).	No Trash or debris located immediately in front of catch basin or on grate opening. No trash or debris in the catch basin. Inlet and outlet pipes free of trash or debris. No dead animals or vegetation present within the catch basin.
	Sediment	Sediment (in the basin) that exceeds 60 percent of the sump depth as measured from the bottom of basin to invert of the lowest pipe into or out of the basin, but in no case less than a minimum of 6 inches clearance from the sediment surface to the invert of the lowest pipe.	No sediment in the catch basin
	Structure Damage to Frame and/or Top Slab	Top slab has holes larger than 2 square inches or cracks wider than 1/4 inch. (Intent is to make sure no material is running into basin). Frame not sitting flush on top slab, i.e., separation of more than 3/4 inch of the frame from the top slab. Frame not securely attached	Top slab is free of holes and cracks. Frame is sitting flush on the riser rings or top slab and firmly attached.
	Fractures or Cracks in Basin Walls/ Bottom	Maintenance person judges that structure is unsound. Grout fillet has separated or cracked wider than 1/2 inch and longer than 1 foot at the joint of any inlet/outlet pipe or any evidence of soil particles entering catch basin through cracks.	Basin replaced or repaired to design standards. Pipe is regouted and secure at basin wall.
	Settlement/ Mis-alignment	If failure of basin has created a safety, function, or design problem.	Basin replaced or repaired to design standards.
	Vegetation	Vegetation growing across and blocking more than 10% of the basin opening. Vegetation growing in inlet/outlet pipe joints that is more than six inches tall and less than six inches apart.	No vegetation blocking opening to basin. No vegetation or root growth present.
	Contamination and Pollution	See Table V-A.1: Maintenance Standards - Detention Ponds	No pollution present.
Catch Basin Cover	Cover Not in Place	Cover is missing or only partially in place. Any open catch basin requires maintenance.	Cover/grate is in place, meets design standards, and is secured
	Locking Mechanism Not Working	Mechanism cannot be opened by one maintenance person with proper tools. Bolts into frame have less than 1/2 inch of thread.	Mechanism opens with proper tools.
	Cover Difficult to Remove	One maintenance person cannot remove lid after applying normal lifting pressure. (Intent is keep cover from sealing off access to maintenance.)	Cover can be removed by one maintenance person.
Ladder	Ladder Rungs Unsafe	Ladder is unsafe due to missing rungs, not securely attached to basin wall, misalignment, rust, cracks, or sharp edges.	Ladder meets design standards and allows maintenance person safe access.
Metal Grates (If Applicable)	Grate opening Unsafe	Grate with opening wider than 7/8 inch.	Grate opening meets design standards.
	Trash and Debris	Trash and debris that is blocking more than 20% of grate surface inletting capacity.	Grate free of trash and debris.
	Damaged or Missing.	Grate missing or broken member(s) of the grate.	Grate is in place, meets the design standards, and is installed and aligned with the flow path.

Table V-A.15: Maintenance Standards - Manufactured Media Filters (continued)

Maintenance Component	Defect	Condition When Maintenance is Needed	Results Expected When Maintenance is Performed	
Vault			compost media.	
	Sediment Accumulation in Vault	Sediment depth exceeds 6-inches in first chamber.	No sediment deposits in vault bottom of first chamber.	
	Trash/Debris Accumulation	Trash and debris accumulated on compost filter bed.	Trash and debris removed from the compost filter bed.	
	Sediment in Drain Pipes/Clean-Outs	When drain pipes, clean-outs, become full with sediment and/or debris.	Sediment and debris removed.	
	Damaged Pipes	Any part of the pipes that are crushed or damaged due to corrosion and/or settlement.	Pipe repaired and/or replaced.	
	Access Cover Damaged/Not Working	Cover cannot be opened; one person cannot open the cover using normal lifting pressure, corrosion/deformation of cover.	Cover repaired to proper working specifications or replaced.	
	Vault Structure Includes Cracks in Wall, Bottom, Damage to Frame and/or Top Slab		Cracks wider than 1/2-inch or evidence of soil particles entering the structure through the cracks, or maintenance/inspection personnel determine that the vault is not structurally sound.	Vault replaced or repairs made so that vault meets design specifications and is structurally sound.
			Cracks wider than 1/2-inch at the joint of any inlet/outlet pipe or evidence of soil particles entering through the cracks.	Vault repaired so that no cracks exist wider than 1/4-inch at the joint of the inlet/outlet pipe.
	Baffles	Baffles corroding, cracking warping, and/or showing signs of failure as determined by maintenance/inspection person.	Baffles repaired or replaced to specifications.	
Access Ladder Damaged	Ladder is corroded or deteriorated, not functioning properly, not securely attached to structure wall, missing rungs, cracks, and misaligned.	Ladder replaced or repaired and meets specifications, and is safe to use as determined by inspection personnel.		
Below Ground Cartridge Type	Media	Drawdown of water through the media takes longer than 1 hour, and/or overflow occurs frequently.	Media cartridges replaced.	
	Short Circuiting	Flows do not properly enter filter cartridges.	Filter cartridges replaced.	

SECTION 7.0: SPECIAL REPORTS AND STUDIES

The following report(s) have been performed on the site:

- Geotechnical Report, Stack Short Plat, prepared by Terra Associates, Inc., dated August 31st, 2022.