

ALTA/NSPS LAND TITLE SURVEY

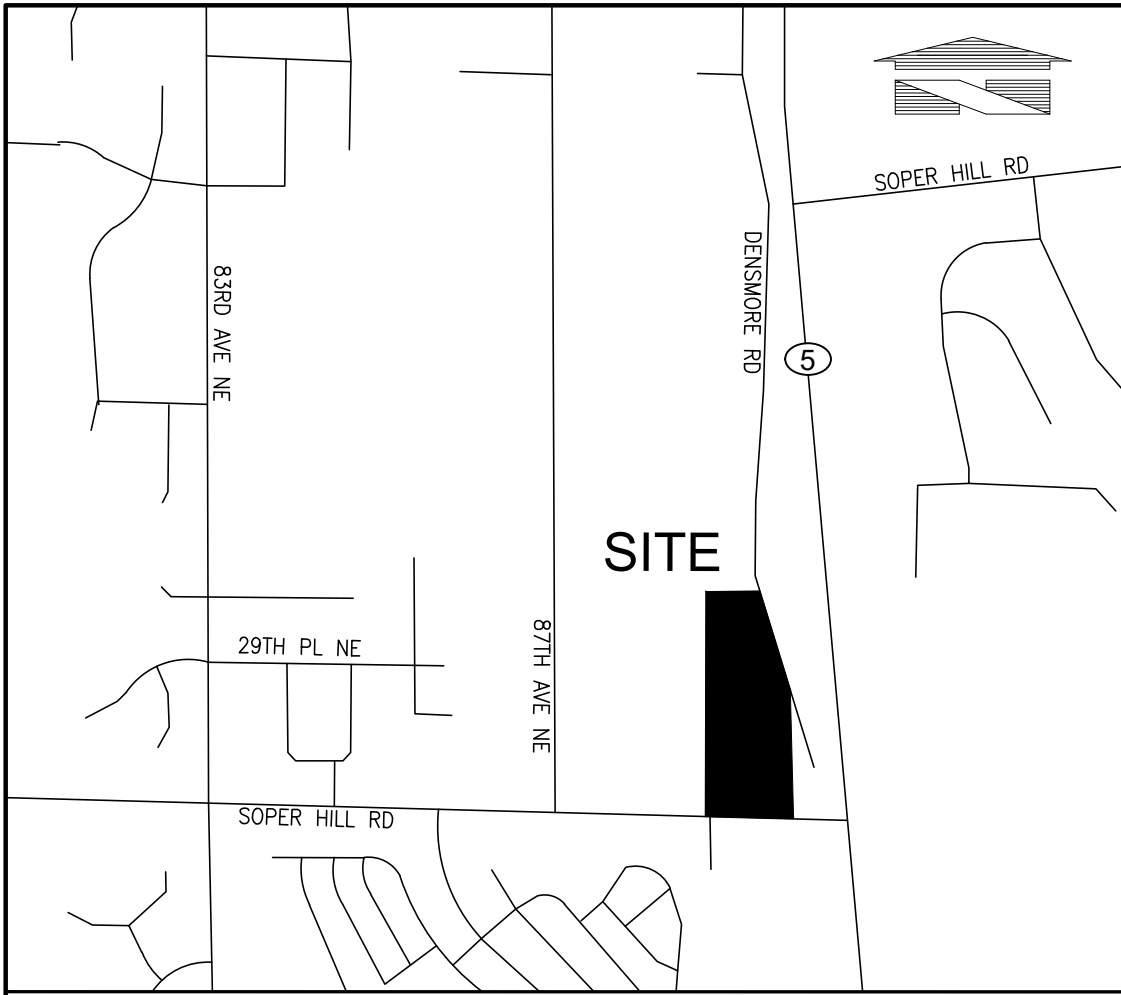

VICINITY MAP SNOHOMISH COUNTY, WASHINGTON

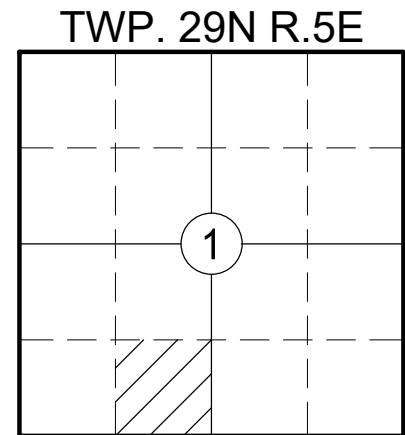

INDEXING INFORMATION
N.T.S.



SURVEYOR'S NOTES:

HORIZONTAL DATUM/BASIS OF BEARINGS:
BASIS OF BEARINGS FOR THIS PROJECT IS NAD83/91 AS ESTABLISHED BY A LINE HELD BETWEEN W.C.C.S. POINT 328 AND W.C.C.S. POINT 326, BEING NORTH 01°10'09" EAST.

VERTICAL DATUM:
THE VERTICAL DATUM FOR THIS PROJECT IS NAVD88. THE BENCHMARK USED IS WSDOT POINT GP31009-196, EAST OF THE SITE NEAR SR-9, BEING 362.84 FEET AS SHOWN.

LOT AREA:
LOT 3 - 41,929± S.F. (0.963± ACRES)
LOT 4 - 58,228± S.F. (1.337± ACRES)
GROSS - 100,157± S.F. (2.299± ACRES)

ADDRESS:
UNASSIGNED

TAX PARCEL NUMBERS:
LOT 3 - 00590700031903
LOT 4 - 00590700031902

REFERENCE SURVEYS:
1. WHITE BARN NON-PROJECT BINDING SITE PLAN, FILE NO. PA20043, AFN 202107205003.
2. WHITE BARN BOUNDARY LINE ADJUSTMENT, FILE NO. BLA22003, AFN 202205135001.

DATE OF SURVEY:
ALL SURVEY CONTROL INDICATED AS "FOUND" WAS RECOVERED FOR THIS PROJECT IN APRIL OF 2023.

TITLE INSURANCE:
ALL TITLE INFORMATION SHOWN ON THIS MAP HAS BEEN EXTRACTED FROM CHICAGO TITLE COMPANY OF WASHINGTON COMMITMENT NO. 500140149, DATED APRIL 11, 2023 AT 8:00 A.M., INCLUDING APPURTENANT EASEMENTS AND ADJOINING DEEDS FOR UNPLATTED LOTS, IF ANY. IN PREPARING THIS MAP, BARGHAUSEN CONSULTING ENGINEERS, INC. HAS CONDUCTED NO INDEPENDENT TITLE SEARCH NOR IS BARGHAUSEN CONSULTING ENGINEERS, INC. AWARE OF ANY TITLE ISSUES AFFECTING THE SURVEYED PROPERTY OTHER THAN THOSE SHOWN ON THE MAP AND DISCLOSED BY SAID COMMITMENT. BARGHAUSEN CONSULTING ENGINEERS, INC. HAS RELIED WHOLLY ON SAID TITLE COMPANY'S REPRESENTATIONS OF THE TITLE'S CONDITION TO PREPARE THIS SURVEY AND THEREFORE BARGHAUSEN CONSULTING ENGINEERS, INC. QUALIFIES THE MAP'S ACCURACY AND COMPLETENESS TO THAT EXTENT.

FLOOD INFORMATION:
FEDERAL EMERGENCY MANAGEMENT AGENCY (FEMA) INFORMATION: FIRM (FLOOD INSURANCE RATE MAP) MAP NO. 53035C0360F PANEL 360 OF 525, DATED FEBRUARY 3, 2017. THE SUBJECT PROPERTY IS IN ZONE X NO SCREEN. AREAS DETERMINED TO BE OUTSIDE THE 0.2% ANNUAL CHANCE FLOODPLAIN.

ZONING INFORMATION:
(A ZONING REPORT WAS NOT FURNISHED FOR THIS SITE)

SURVEYOR'S NOTES:

- ALL DISTANCES SHOWN HEREON ARE GROUND MEASUREMENTS IN U.S. SURVEY FEET.
- THE BOUNDARY CORNERS AND LINES DEPICTED ON THIS MAP REPRESENT DEED LINES ONLY, AND DON'T PURPORT TO SHOW OWNERSHIP LINES THAT MAY OTHERWISE BE DETERMINED BY A COURT OF LAW. NO GUARANTEE OF OWNERSHIP IS EXPRESSED OR IMPLIED. NO PROPERTY CORNERS WERE SET FOR THIS SURVEY.
- ONLY SURFACE EVIDENCE OF UNDERGROUND UTILITIES WAS OBSERVED FOR THIS SURVEY. NO UNDERGROUND LOCATES WERE PERFORMED. UNDERGROUND UTILITIES MAY EXIST WITHIN THE MAPPING LIMITS.
- THE LEGAL DESCRIPTION AND SPECIAL EXCEPTIONS SHOWN HEREON ARE PER PUBLIC RECORD. THIS SURVEY WAS COMPLETED WITHOUT THE BENEFIT OF A TITLE REPORT. EASEMENTS, UNWRITTEN RIGHTS OR OTHER MATTERS RELATED TO TITLE MAY AFFECT THE SUBJECT PROPERTY. CONSULT A TITLE REPORT FOR SUCH MATTERS.
- THIS SURVEY HAS DEPICTED ALL VISIBLE OCCUPANCY INDICATORS (E. FENCE LINES, BUILDINGS, WALLS, ETC. - SEE MAP FOR PARTICULARS) PER W.A.C. 332-130. LINES OF OCCUPATION, AS DEPICTED, MAY INDICATE AREAS OF POTENTIAL CLAIMS OF UNWRITTEN OWNERSHIP. THIS SURVEY HAS ONLY DEPICTED THE RELATIONSHIP BETWEEN LINES OF OCCUPATION AND DEEDED LINES OF RECORD. NO RESOLUTION OF OWNERSHIP BASED ON UNWRITTEN RIGHTS HAS BEEN MADE BY THIS SURVEY OR BY ANY PERSONNEL OF BARGHAUSEN CONSULTING ENGINEERS, INC.
- THIS SURVEY MEETS OR EXCEEDS THE "RELATIVE POSITIONAL PRECISION" REQUIREMENTS SET FORTH IN THE 2021 MINIMUM STANDARD DETAIL REQUIREMENTS FOR ALTA/NSPS LAND TITLE SURVEYS IN SECTION 3(E).
- THE RECORD DESCRIPTION FOR THE SUBJECT PROPERTY IS BASED ON THE REFERENCED PLAT AND MATHEMATICALLY CLOSES.
- SITE IS UNDER CONSTRUCTION WITH EARTHWORK ACTIVITY ON GOING DURING LAST SITE VISIT.

TITLE INFORMATION:

LEGAL DESCRIPTION:
(PER ABOVE REFERENCED TITLE REPORT)

LOTS 3 AND 4 OF BINDING SITE PLAN, RECORDED UNDER AUDITOR'S FILE NO. 202107205003, RECORDS OF SNOHOMISH COUNTY, WASHINGTON, BEING A PORTION OF LOT 319, SUNNY SIDE FIVE ACRE TRACTS, ACCORDING TO THE PLAT THEREOF, RECORDED IN VOLUME 7 OF PLATS, PAGE 19, RECORDS OF SNOHOMISH COUNTY, WASHINGTON.

SITUATE IN THE COUNTY OF SNOHOMISH, STATE OF WASHINGTON.

SPECIAL EXCEPTIONS:

(PER ABOVE REFERENCED TITLE REPORT)

1. COVENANTS, CONDITIONS, RESTRICTIONS, RECITALS, RESERVATIONS, EASEMENTS, EASEMENT PROVISIONS, ENCROACHMENTS, DEDICATIONS, BUILDING SETBACK LINES, NOTES, STATEMENTS, AND OTHER MATTERS, IF ANY, BUT OMITTING ANY COVENANTS OR RESTRICTIONS, IF ANY, INCLUDING BUT NOT LIMITED TO THOSE BASED UPON RACE, COLOR, RELIGION, SEX, SEXUAL ORIENTATION, FAMILIAL STATUS, MARITAL STATUS, DISABILITY, HANDICAP, NATIONAL ORIGIN, ANCESTRY, OR SOURCE OF INCOME, AS SET FORTH IN APPLICABLE STATE OR FEDERAL LAWS, EXCEPT TO THE EXTENT THAT SAID COVENANT OR RESTRICTION IS PERMITTED BY APPLICABLE LAW, AS SET FORTH ON THE PLAT OF SUNNY SIDE FIVE ACRE TRACTS:
RECORDING NO.: 122901
(NO EASEMENTS)

2. EASEMENT(S) FOR THE PURPOSE(S) SHOWN BELOW AND RIGHTS INCIDENTAL THERETO, AS GRANTED IN A DOCUMENT:
GRANTED TO: CITY OF SEATTLE
PURPOSE: ELECTRIC TRANSMISSION AND/OR DISTRIBUTION LINE
RECORDING DATE: JULY 13, 1922
RECORDING NO.: 301077
AFFECTS: PORTION OF SAID PREMISES
(NOT PLOTTED; APPLICABLE TO OFF-SITE PROPERTY TO THE EAST)

3. EASEMENT(S) FOR THE PURPOSE(S) SHOWN BELOW AND RIGHTS INCIDENTAL THERETO, AS GRANTED IN A DOCUMENT:
GRANTED TO: UNITED STATES OF AMERICA
PURPOSE: ELECTRIC TRANSMISSION AND/OR DISTRIBUTION LINE RECORDING
DATE: MAY 18, 1951
RECORDING NO.: 992286
AFFECTS: PORTION OF SAID PREMISES
(PLOTTED HEREON)

4. RESERVATIONS AND RECITALS CONTAINED IN RELEASE AND WAIVER OF INTEREST, AS SET FORTH BELOW:
RECORDING DATE: JANUARY 3, 1958
RECORDING NO.: 1266154
(NOT SURVEY RELATED)

5. EASEMENT(S) FOR THE PURPOSE(S) SHOWN BELOW AND RIGHTS INCIDENTAL THERETO, AS GRANTED IN A DOCUMENT:
GRANTED TO: NORTHWEST PIPELINE CORP
PURPOSE: OPERATION OF PIPELINE
RECORDING DATE: NOVEMBER 19, 2003
RECORDING NO.: 20031190243

AN ASSIGNMENT OF INTEREST UNDER SAID EASEMENT WHICH NAMES:
ASSIGNEE: PUGET SOUND ENERGY, INC.
RECORDING DATE: DECEMBER 10, 2003
RECORDING NO.: 200312100717
(NOT PLOTTED; APPLICABLE TO OFF-SITE PROPERTY TO THE EAST)

6. COVENANTS, CONDITIONS, RESTRICTIONS, RECITALS, RESERVATIONS, EASEMENTS, EASEMENT PROVISIONS, ENCROACHMENTS, DEDICATIONS, BUILDING SETBACK LINES, NOTES, STATEMENTS, AND OTHER MATTERS, IF ANY, BUT OMITTING ANY COVENANTS OR RESTRICTIONS, IF ANY, INCLUDING BUT NOT LIMITED TO THOSE BASED UPON RACE, COLOR, RELIGION, SEX, SEXUAL ORIENTATION, FAMILIAL STATUS, MARITAL STATUS, DISABILITY, HANDICAP, NATIONAL ORIGIN, ANCESTRY, OR SOURCE OF INCOME, AS SET FORTH IN APPLICABLE STATE OR FEDERAL LAWS, EXCEPT TO THE EXTENT THAT SAID COVENANT OR RESTRICTION IS PERMITTED BY APPLICABLE LAW, AS SET FORTH ON SURVEY:
RECORDING NO.: 200403035222
(NO EASEMENTS)

7. EASEMENT(S) FOR THE PURPOSE(S) SHOWN BELOW AND RIGHTS INCIDENTAL THERETO, AS GRANTED IN A DOCUMENT:

GRANTED TO: NORTHWEST PIPELINE CORPORATION
PURPOSE: GAS PIPELINE
RECORDING DATE: MARCH 18, 2004
RECORDING NO.: 200403180002
AFFECTS: PORTION OF SAID PREMISES
(NOT PLOTTED; APPLICABLE TO OFF-SITE PROPERTY TO THE EAST)

8. RELINQUISHMENT OF ACCESS TO STATE HIGHWAY NUMBER STATE ROUTE 9 AND OF LIGHT, VIEW AND AIR BY DEED:
GRANTED: STATE OF WASHINGTON
RECORDING DATE: FEBRUARY 16, 2011
RECORDING NO.: 201102160549
AFFECTS: PORTION OF SAID PREMISES
(NOT PLOTTED; APPLICABLE TO OFF-SITE PROPERTY TO THE EAST)

9. COVENANTS, CONDITIONS, RESTRICTIONS AND EASEMENTS BUT OMITTING ANY COVENANTS OR RESTRICTIONS, IF ANY, INCLUDING BUT NOT LIMITED TO THOSE BASED UPON RACE, COLOR, RELIGION, SEX, SEXUAL ORIENTATION, FAMILIAL STATUS, MARITAL STATUS, DISABILITY, HANDICAP, NATIONAL ORIGIN, ANCESTRY, SOURCE OF INCOME, GENDER, GENDER IDENTITY, GENDER EXPRESSION, MEDICAL CONDITION OR GENETIC INFORMATION, AS SET FORTH IN APPLICABLE STATE OR FEDERAL LAWS, EXCEPT TO THE EXTENT THAT SAID COVENANT OR RESTRICTION IS PERMITTED BY APPLICABLE LAW, AS SET FORTH IN THE DOCUMENT:
RECORDING DATE: JULY 20, 2021
RECORDING NO.: 202107200226
AFFECTS: PORTION OF SAID PREMISES
MODIFICATION(S) OF SAID COVENANTS, CONDITIONS AND RESTRICTIONS

RECORDING DATE: OCTOBER 6, 2021
RECORDING NO.: 202110060833
(PLOTTED HEREON)

10. COVENANTS, CONDITIONS, RESTRICTIONS, RECITALS, RESERVATIONS, EASEMENTS, EASEMENT PROVISIONS, ENCROACHMENTS, DEDICATIONS, BUILDING SETBACK LINES, NOTES, STATEMENTS, AND OTHER MATTERS, IF ANY, BUT OMITTING ANY COVENANTS OR RESTRICTIONS, IF ANY, INCLUDING BUT NOT LIMITED TO THOSE BASED UPON RACE, COLOR, RELIGION, SEX, SEXUAL ORIENTATION, FAMILIAL STATUS, MARITAL STATUS, DISABILITY, HANDICAP, NATIONAL ORIGIN, ANCESTRY, OR SOURCE OF INCOME, AS SET FORTH IN APPLICABLE STATE OR FEDERAL LAWS, EXCEPT TO THE EXTENT THAT SAID COVENANT OR RESTRICTION IS PERMITTED BY APPLICABLE LAW, AS SET FORTH ON WHITE BARN NON-PROJECT BINDING SITE PLAN, CITY OF MARYSVILLE, WA FILE NO. PA20043:
RECORDING NO.: 202107205003
(PLOTTED HEREON)

11. EASEMENT(S) FOR THE PURPOSE(S) SHOWN BELOW AND RIGHTS INCIDENTAL THERETO, AS GRANTED IN A DOCUMENT:

GRANTED TO: PUBLIC UTILITY DISTRICT NO. 1 OF SNOHOMISH COUNTY
PURPOSE: DISTRIBUTION EASEMENT
RECORDING DATE: JUNE 1, 2022
RECORDING NO.: 202206010410
AFFECTS: SAID PREMISES AND OTHER PROPERTY
(NOT PLOTTABLE/BLANKET IN NATURE)

12. ALTA SURVEY MADE BY BARGHAUSEN AND CONSULTING ENGINEERS UNDER JOB NO. 16707, DATED OCTOBER 25, 2013, DISCLOSED BY STATUTORY WARRANTY DEED:
RECORDING DATE: JULY 12, 2021
RECORDING NO.: 202107120019
(PLOTTED HEREON)

ITEMS 13. THROUGH 19. ARE NOT SURVEY RELATED. SEE TITLE REPORT FOR PARTICULARS

20. EASEMENT(S) FOR THE PURPOSE(S) SHOWN BELOW AND RIGHTS INCIDENTAL THERETO, AS GRANTED IN A DOCUMENT:

GRANTED TO: PUGET SOUND ENERGY, INC.
PURPOSE: TRANSMISSION AND DISTRIBUTION OF GAS
RECORDING DATE: MARCH 21, 2023
RECORDING NO.: 202303210278
(NOT PLOTTABLE/BLANKET IN NATURE)

SURVEYOR'S CERTIFICATION:

TO: NATURAL 9 HOLDINGS LLC, A WASHINGTON LIMITED LIABILITY COMPANY, AND: CHICAGO TITLE COMPANY OF WASHINGTON:

THIS IS TO CERTIFY THAT THIS MAP OR PLAT AND THE SURVEY ON WHICH IT IS BASED WERE MADE IN ACCORDANCE WITH THE 2021 MINIMUM STANDARD DETAIL REQUIREMENTS FOR ALTA/NSPS LAND TITLE SURVEYS, JOINTLY ESTABLISHED AND ADOPTED BY ALTA AND NSPS, AND INCLUDES ITEMS 2, 3, 4, 6(a), 7(a), 7(b)(1), 8, 9, 11, 13 AND 16 OF TABLE A THEREOF. THE FIELDWORK WAS COMPLETED ON APRIL 13, 2023.

DATE OF PLAT OR MAP: APRIL 21, 2023.

Matthew K Abbas
MATTHEW K ABBAS, PLS
WASHINGTON REGISTRATION NO. 20109892

4/21/2023
DATE



Job Number 22681	Barghausen Consulting Engineers, Inc. 18215 72nd Avenue South Kent, WA 98032 425.251.6222 barghausen.com	Designed <u> </u> Drawn <u>KJR</u> Checked <u>MKA</u> Approved <u>MKA</u> Date <u>4/21/23</u>	Scale: Horizontal	For: BROWN BEAR CARWASH	No.	Date	By	Ckd.	Appr.	Revision	
Sheet 2 of 2											
Title:					ALTA/NSPS LAND TITLE SURVEY PTN OF THE SE1/4 OF THE SW1/4 OF SEC. 1, TWP. 29 N., RGE 5 E., W. M. SNOHOMISH COUNTY, STATE OF WASHINGTON						

