

 **TRAFFIC IMPACT ANALYSIS**

CORNELIUS LACEY

JURISDICTION: CITY OF MARYSVILLE, WA
LOCATION: 83RD AVE NE, SOUTH OF E SUNNYSIDE SCHOOL RD

Prepared for:
Land Pro Group Inc.
10515 20th Street SE
Suite 202
Lake Stevens, Washington 98258

Prepared by:
Kimley»»Horn

March 2024
090223146
Copyright © Kimley-Horn and Associates, Inc.



TRAFFIC IMPACT ANALYSIS

FOR

CORNELIUS LACEY

Prepared for:

Land Pro Group Inc.

10515 20th Street SE

Suite 202

Lake Stevens, Washington 98258

Prepared by:

Kimley-Horn and Associates, Inc.

2828 Colby Avenue

Suite 200

Everett, Washington 98201

(425) 708-8275



This document, together with the concepts and designs presented herein, as an instrument of service, is intended only for the specific purpose and client for which it was prepared. Reuse of and improper reliance on this document without written authorization and adaptation by Kimley-Horn and Associates, Inc. shall be without liability to Kimley-Horn and Associates, Inc.

© March 2024
090223146

TABLE OF CONTENTS

1. DEVELOPMENT IDENTIFICATION 1

2. METHODOLOGY 1

3. TRIP GENERATION 4

4. TRIP DISTRIBUTION 4

5. INTERSECTION LEVEL OF SERVICE ANALYSIS..... 5

 5.1. Turning Movement Calculations..... 10

 5.1.1. Intersection Volumes 10

 5.2. Level of Service Calculations 16

6. SITE ACCESS..... 16

7. TRANSPORTATION IMPACT FEES 17

 7.1. City of Marysville 17

 7.2. Snohomish County 17

 7.3. Washington State Department of Transportation..... 17

8. CONCLUSIONS 17

LIST OF FIGURES

Figure 1: Site Vicinity Map 2

Figure 2: Trip Distribution Opening Year – AM Peak-Hour..... 6

Figure 3: Trip Distribution Opening Year – PM Peak-Hour..... 7

Figure 4: Trip Distribution Horizon Year – AM Peak-Hour..... 8

Figure 5: Trip Distribution Horizon Year – PM Peak-Hour..... 9

Figure 6: 2023 Existing Turning Movements 11

Figure 7: 2026 Opening-Year Baseline Turning Movements..... 12

Figure 8: 2026 Opening-Year Future with Development Turning Movements 13

Figure 9: 2032 Horizon-Year Future with Development Turning Movements 14

Figure 10: 2032 Horizon-Year Future with Development Turning Movements 15

LIST OF TABLES

Table 1: Level of Service Criteria 3

Table 2: Trip Generation Summary 4

Table 3: Key Intersection Volumes – AM Peak Hour 10

Table 4: Key Intersection Volumes – PM Peak Hour 10

Table 5: Level of Service Summary – 2026 Opening-Year 16

Table 6: Level of Service Summary – 2032 Horizon-Year 16

LIST OF APPENDICES

SITE PLAN A

TRIP GENERATION CALCULATIONS B

DISTRIBUTION AND COUNT DATA C

TURNING MOVEMENT CALCULATIONS D

LEVEL OF SERVICE CALCULATIONS E

1. DEVELOPMENT IDENTIFICATION

Kimley-Horn and Associates, Inc. (Kimley-Horn) has been retained to provide a traffic impact analysis for the Cornelius Lacey Development (Development). This report is intended to provide the City of Marysville (City) and Snohomish County (County) with the necessary traffic generation, trip distribution, and mitigation fee determination to facilitate their reviews of the Development. This report also addresses City comments dated February 28, 2024. The Development is located on the east side of 83rd Avenue NE, south of E Sunnyside School Road. A site vicinity map is included in **Figure 1**. The Development is proposed to consist of 67 single-family detached residential units. The site is currently listed as developed with two single-family detached units and one mobile home per the *Snohomish County Online Property Information (SCOPI)* web map. The site will primarily access the City street network via one proposed access drive connected to 83rd Avenue NE. A site plan has been provided in **Appendix A**.

Brad Lincoln, responsible for this report and traffic analysis, is a licensed professional engineer (Civil) in the State of Washington and member of the Washington State section of the Institute of Transportation Engineers (ITE).

2. METHODOLOGY

Congestion at intersections and along arterials is generally measured in terms of level of service (LOS). In accordance with *Highway Capacity Manual (HCM)*, 6th Edition by the Transportation Research Board, road facilities and intersections are rated between LOS A and LOS F, with LOS A being free flow and LOS F being forced flow or over-capacity conditions. The LOS at signalized, roundabout, and all-way stop-controlled intersections is based on the average delay of all approaches. The LOS for two-way stop-controlled intersections is based on average delays for the critical stopped approach. Geometric characteristics and conflicting traffic movements are taken into consideration when determining LOS values. A summary of the intersection LOS criteria is included in **Table 1**.

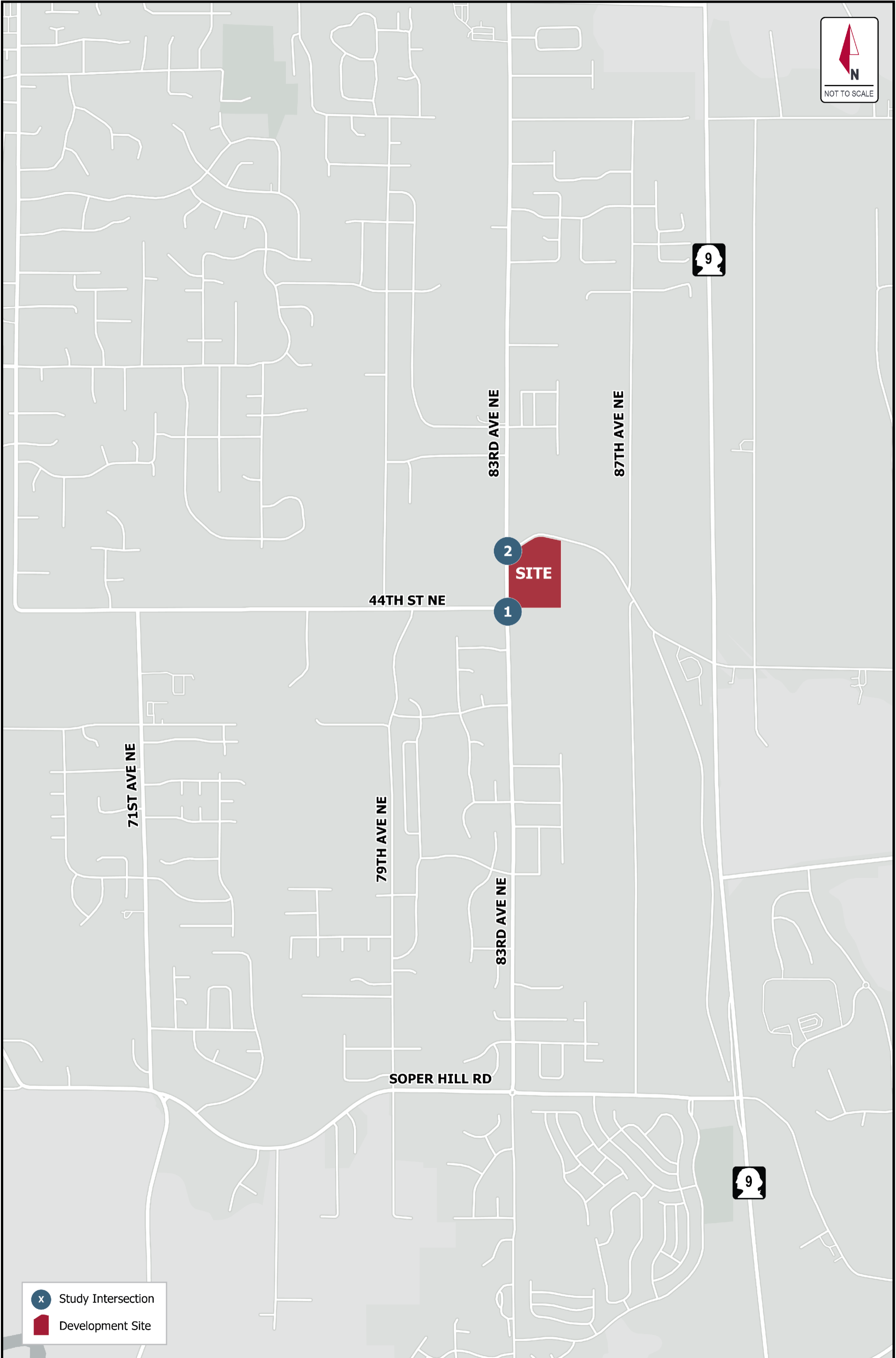

-  Study Intersection
-  Development Site

FIGURE 1 - SITE VICINITY MAP

090223146 CORNELIUS LACEY - CITY OF MARYSVILLE

Table 1: Level of Service Criteria

Level of Service ¹	Expected Delay	Intersection Control Delay (Seconds per Vehicle)	
		Unsignalized Intersections	Signalized Intersections
A	Little/No Delay	≤10	≤10
B	Short Delays	>10 and ≤15	>10 and ≤20
C	Average Delays	>15 and ≤25	>20 and ≤35
D	Long Delays	>25 and ≤35	>35 and ≤55
E	Very Long Delays	>35 and ≤50	>55 and ≤80
F	Extreme Delays ²	>50	>80

The LOS at two-way stop-controlled intersections is based on the average delay for the stopped approach with the highest delay. The LOS at all-way stop-controlled intersections and signalized intersections is based on the average delay for all vehicles. The LOS analysis for unsignalized and signalized intersections has been performed utilizing the *Synchro 11* software. The City identifies acceptable level of service for intersections as LOS D for all intersections.

The trip generation calculations for the Development are based on average trip generation rates published in the *ITE Trip Generation Manual, 11th Edition (2021)*. The opening year has been estimated for the year 2026, which accounts for a three-year construction window. The horizon year has therefore been evaluated for the year 2032.

¹ **Source:** *Highway Capacity Manual, 6th Edition*.

LOS A: Free-flow traffic conditions, with minimal delay to stopped vehicles (no vehicle is delayed longer than one cycle at signalized intersection).

LOS B: Generally stable traffic flow conditions.

LOS C: Occasional back-ups may develop but delay to vehicles is short term and still tolerable.

LOS D: During short periods of the peak hour, delays to approaching vehicles may be substantial but are tolerable during times of less demand (i.e., vehicles delayed one cycle or less at signal).

LOS E: Intersections operate at or near capacity, with long queues developing on all approaches and long delays.

LOS F: Jammed conditions on all approaches with excessively long delays and vehicles unable to move at times.

² When demand volume exceeds the capacity of the lane, extreme delays will be encountered with queuing which may cause severe congestion affecting other traffic movements in the intersection.

3. TRIP GENERATION

The Development is proposed to consist of 67 single-family detached units. The site is currently developed with two single-family detached units and a mobile home. The trip generation calculations have been performed using data published by the ITE *Trip Generation Manual, 11th Edition (2021)* and the City rate of 1.0 PM peak-hour trips per single-family residential unit. The average trip generation rates for ITE Land Use Codes (LUC) 210, Single-Family Detached Housing, and ITE LUC 240, Mobile Home, have been used for the trip generation calculations. The trip generation calculations for the Development are summarized in **Table 2**.

Table 2: Trip Generation Summary

Land Use	Size	Average Daily Trips (ADTs)	AM Peak-Hour Trips			PM Peak-Hour Trips		
			In	Out	Total	In	Out	Total
Single-Family Detached Housing ITE LUC 210	67 Units	632	12	35	47	42	25	67
Single-Family Detached Housing ITE LUC 210 (Removed)	-2 Units	-19	0	-1	-1	-1	-1	-2
Mobile Home ITE LUC 240 (Removed)	-1 Unit	-7	0	0	0	-1	0	-1
TOTAL		606	12	34	46	40	24	64

The Development is anticipated to generate approximately 606 new ADTs with approximately 46 new AM peak-hour trips and 64 new PM peak-hour trips. The trip generation calculations are provided in **Appendix B**.

4. TRIP DISTRIBUTION

The trip distribution for the Development is based on comparison of Whiskey Ridge North and Whiskey Ridge East distributions established by the City since the site is located in the middle of the two areas. The trip distribution for the 2026 opening year is:

- 30% to and from the north along 83rd Avenue NE
- 28% to and from the east
 - 20% to and from the south along SR-9
 - 5% to and from the east along SR-92
 - 3% to and from the north along SR-9
- 22% to and from the south along 83rd Avenue NE
- 20% to and from the west along 44th Street NE

The trip distribution for the 2032 horizon year is:

- 33% to and from the east
 - 25% to and from the south along SR-9
 - 5% to and from the east along SR-92
 - 3% to and from the north along SR-9
- 30% to and from the north along 83rd Avenue NE
- 15% to and from the south along 83rd Avenue NE
- 22% to and from the west along 44th Street NE

The Horizon Year distribution accounts for future connections south of the site and the conversion of Sunnyside School Road to a pedestrian trail. Detailed trip distributions for the AM peak-hour and PM peak-hour during existing conditions are shown in **Figure 2**, and **Figure 3**, respectively. Detailed trip distributions for the AM peak-hour and PM peak-hour during horizon-year conditions are shown in **Figure 4**, and **Figure 5**, respectively. The established distributions are provided in **Appendix C**.

5. INTERSECTION LEVEL OF SERVICE ANALYSIS

The following intersections have been analyzed based on an impact of 25 trips generated by the Development:

1. 83rd Avenue NE at Line Road/44th Street NE
2. 83rd Avenue NE at E Sunnyside School Road

The intersections have been analyzed for the weekday PM peak-hour.

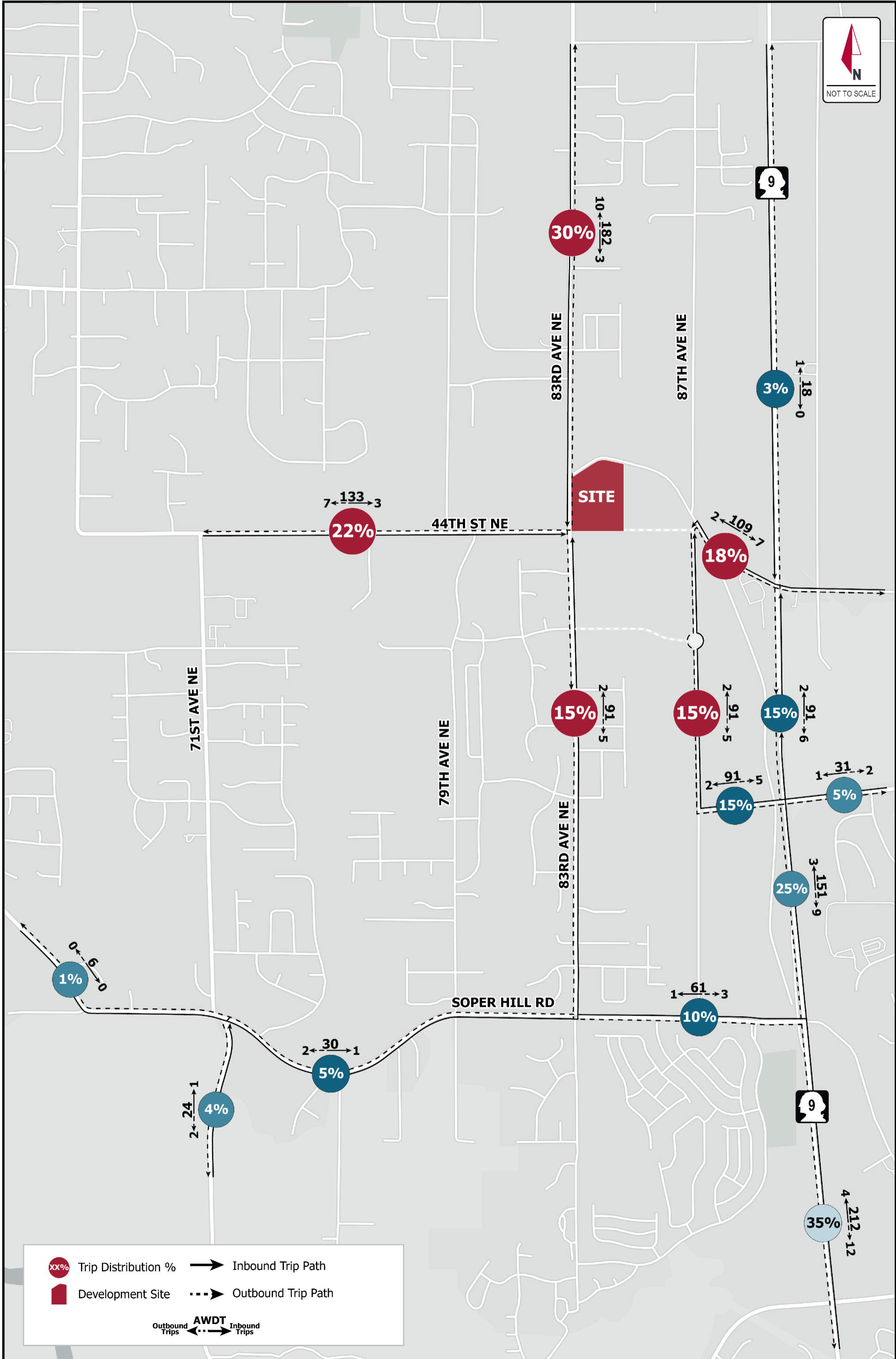

FIGURE 4 - AM PEAK HOUR HORIZON YEAR TRIP DISTRIBUTION
090223146 CORNELIUS LACEY - CITY OF MARYSVILLE

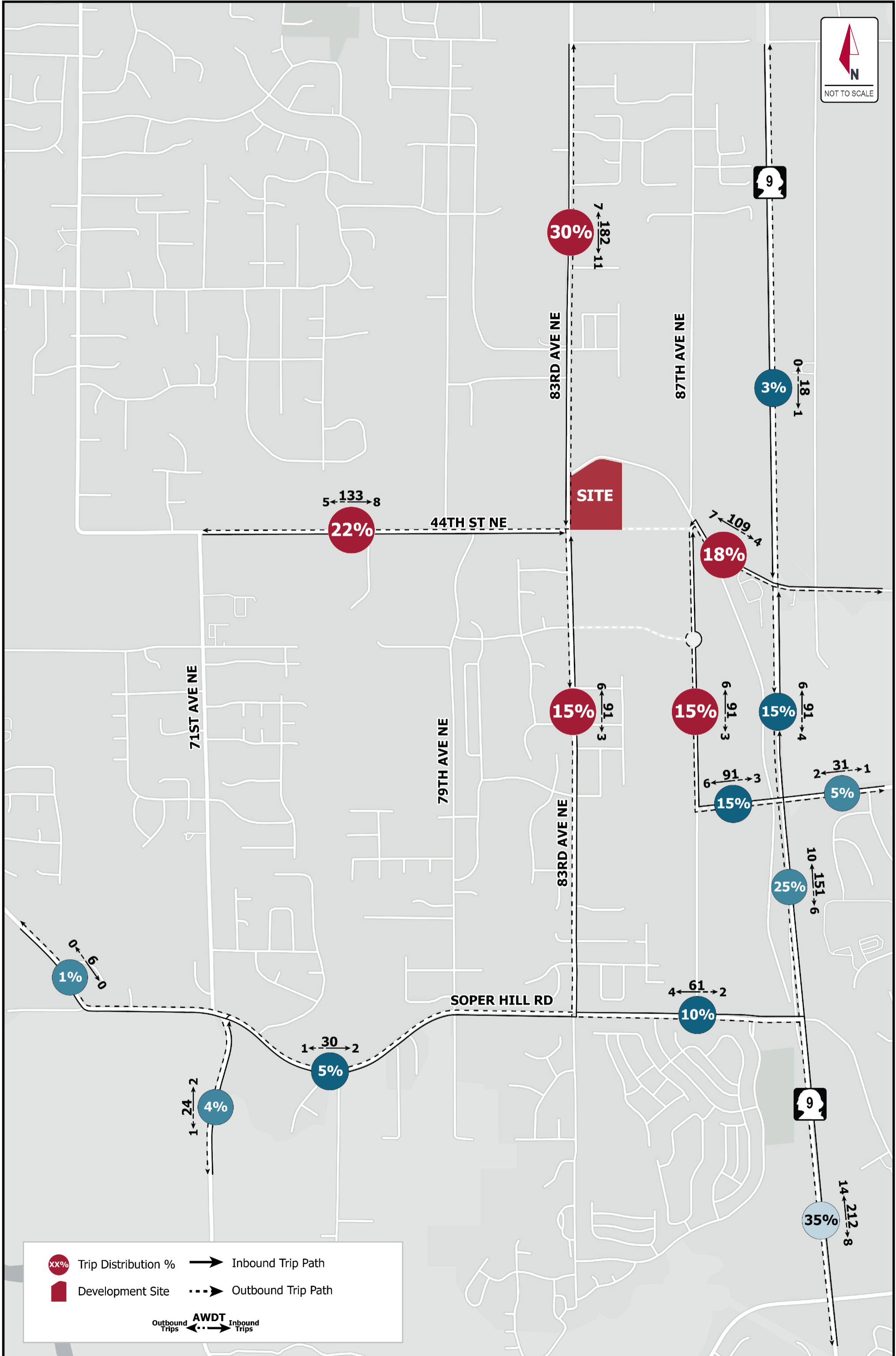

FIGURE 5 - PM PEAK HOUR HORIZON YEAR TRIP DISTRIBUTION
 090223146 CORNELIUS LACEY - CITY OF MARYSVILLE

5.1. Turning Movement Calculations

The interlocal agreement between the City and County requires detailed development trip turning movement data at County key intersections impacted with three or more directional trips on an approach or departure. The Development will impact two key intersections during the AM peak-hour and PM Peak-hour. The AM peak-hour key intersection impacts are shown in tabular form in **Table 3** and the PM peak-hour key intersection impacts are shown in tabular form in **Table 4**.

Table 3: Key Intersection Volumes – AM Peak Hour

Intersection	EBL	EBT	EBR	WBL	WBT	WBR	NBL	NBT	NBR	SBL	SBT	SBR
#147: SR-9 at S Lake Stevens Road	0	0	0	0	0	0	0	4	0	0	13	0
#420: SR-9 at 32 nd Street SE	0	0	0	0	0	0	0	4	0	0	13	0

Table 4: Key Intersection Volumes – PM Peak Hour

Intersection	EBL	EBT	EBR	WBL	WBT	WBR	NBL	NBT	NBR	SBL	SBT	SBR
#147: SR-9 at S Lake Stevens Road	0	0	0	0	0	0	0	14	0	0	8	0
#420: SR-9 at 32 nd Street SE	0	0	0	0	0	0	0	14	0	0	8	0

The key intersection impacts are also shown in graphical form in **Figure 2** and **Figure 3** for the AM and PM peak-hours, respectively.

5.1.1. Intersection Volumes

The existing PM peak-hour turning movements at the study intersections were collected by the independent count firm Traffic Data Gathering (TDG) in March 2023. The 2023 existing turning movements at the study intersections are shown in **Figure 6**. The count data is included in **Appendix C**.

The future analysis has been performed for an opening year of 2026, which represents when the Development is expected to be constructed and occupied. The 2026 opening year baseline turning movements have been calculated by applying a 3% annually compounding growth rate applied to the 2023 existing turning movements. The 2026 opening year baseline turning movements at the study intersections are shown in **Figure 7**. The 2026 opening year future with development turning movements at the study intersections have been calculated by adding the trips generated by the Development to the 2026 opening year baseline turning movements. The 2026 opening year future with development turning movements are shown in **Figure 8**.

The horizon year analysis accounts for the typical six-year concurrency period after the expected opening year. The 2032 horizon year baseline turning movements have been calculated using the same 3% annually compounding growth rate. Sunnyside School Road is planned to be converted to a pedestrian trail and will therefore not be an intersection under the 2032 horizon year conditions. The volumes calculated to be turning to and from Sunnyside School Road under the 2032 baseline conditions have been assigned to the 44th Street NE intersection with the addition of 50 eastbound and westbound through trips to account for the potential diversion of trips with the closure. The 2032 horizon year baseline turning movements at the study intersection is shown in **Figure 9**. The 2032 horizon year future with development turning movements at the study intersection has been calculated by adding the trips generated by the Development to the 2032 horizon year baseline turning movements. The 2032 horizon year future with development turning movements are shown in **Figure 10**. The turning movement calculations are included in **Appendix D**.

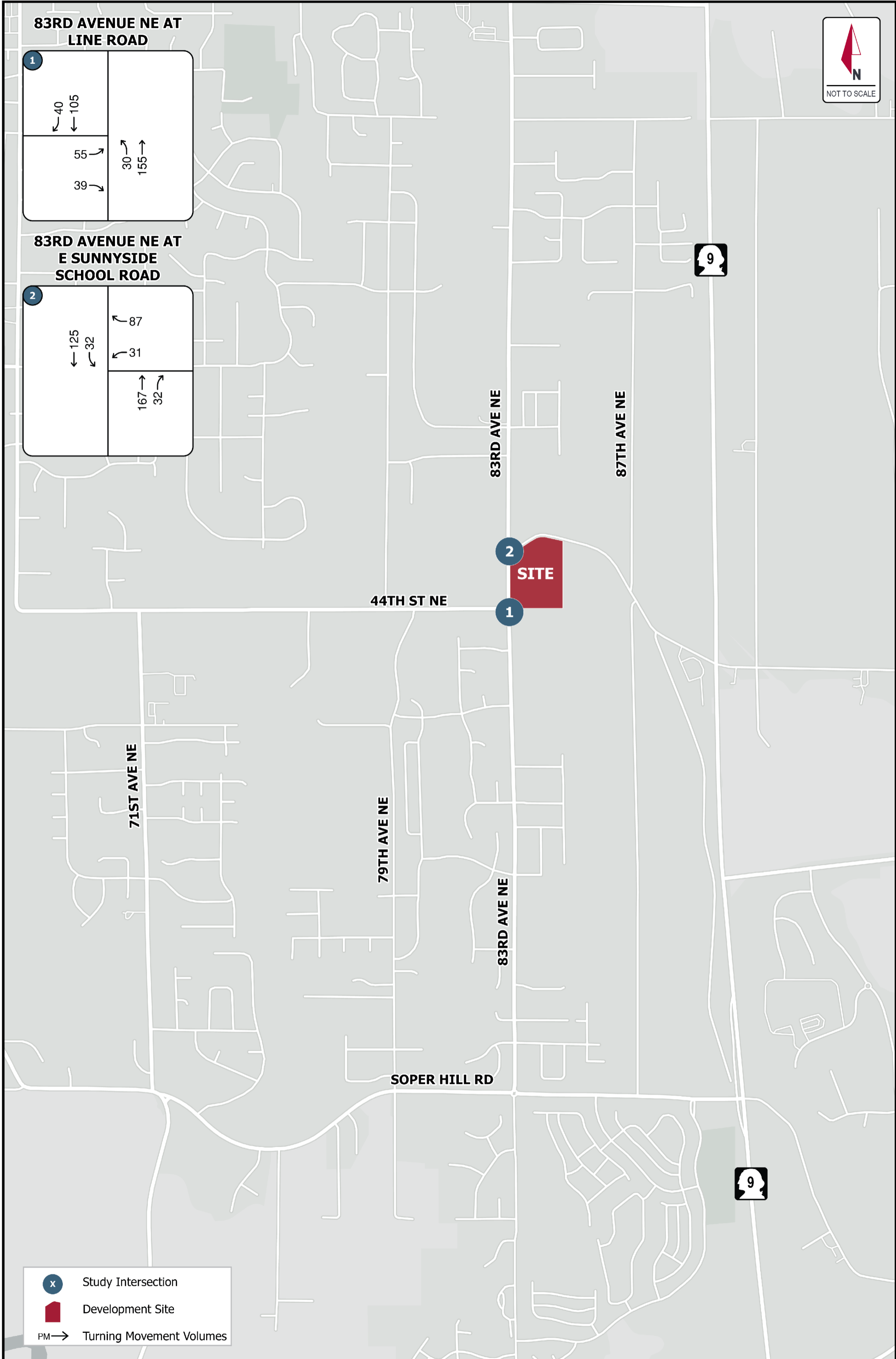

FIGURE 6 - 2023 EXISTING TURNING MOVEMENTS
 090223146 CORNELIUS LACEY - CITY OF MARYSVILLE

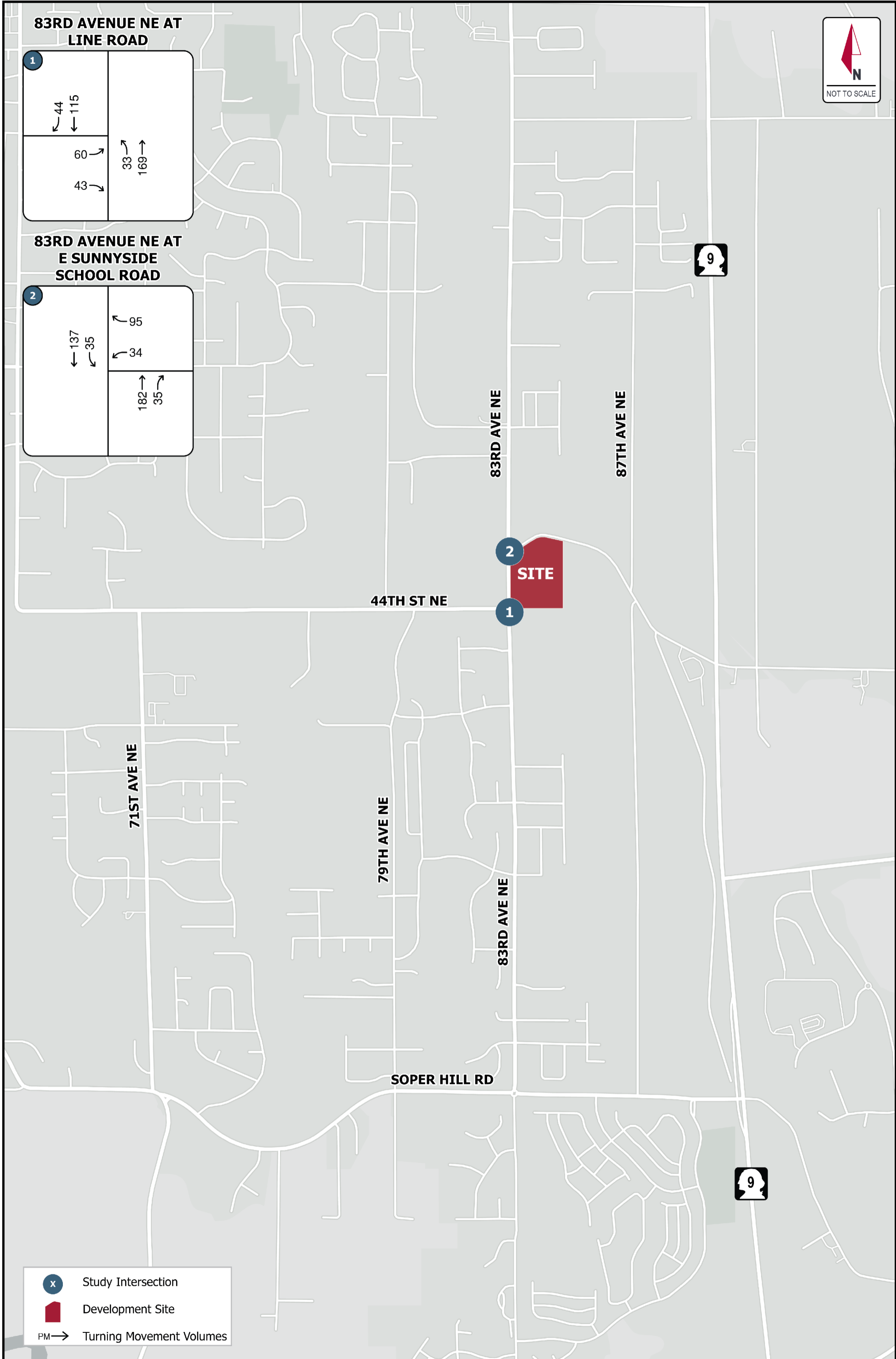
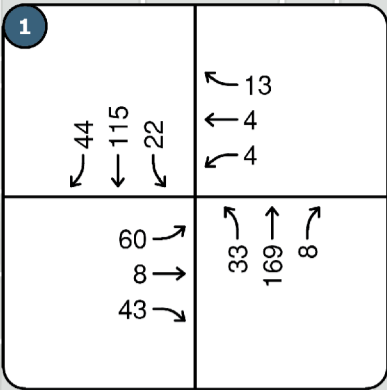

FIGURE 7 - 2026 BASELINE TURNING MOVEMENTS
090223146 CORNELIUS LACEY - CITY OF MARYSVILLE



**83RD AVENUE NE AT
LINE ROAD**



**83RD AVENUE NE AT
E SUNNYSIDE
SCHOOL ROAD**

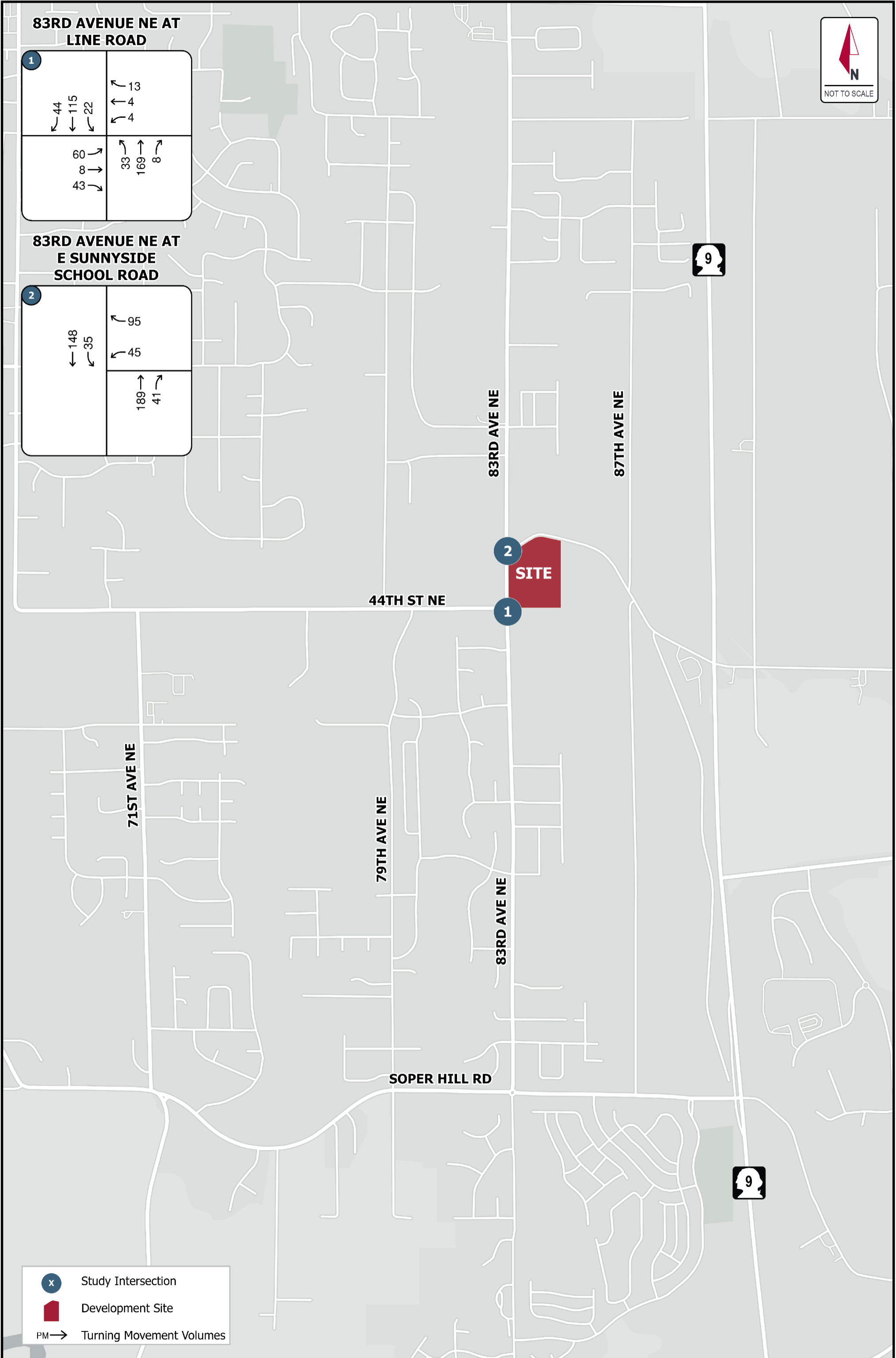
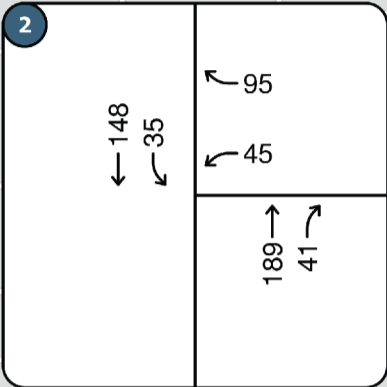

	Study Intersection
	Development Site
	Turning Movement Volumes

FIGURE 8 - 2026 FUTURE TURNING MOVEMENTS
090223146 CORNELIUS LACEY - CITY OF MARYSVILLE

**83RD AVENUE NE AT
LINE ROAD**

1	<p>52 ←</p> <p>137 ←</p> <p>42 ←</p>	<p>114 ↗</p> <p>50 ↑</p> <p>40 ↖</p>
	<p>72 ↗</p> <p>50 →</p> <p>51 ↘</p>	<p>39 ↗</p> <p>202 →</p> <p>42 ↘</p>

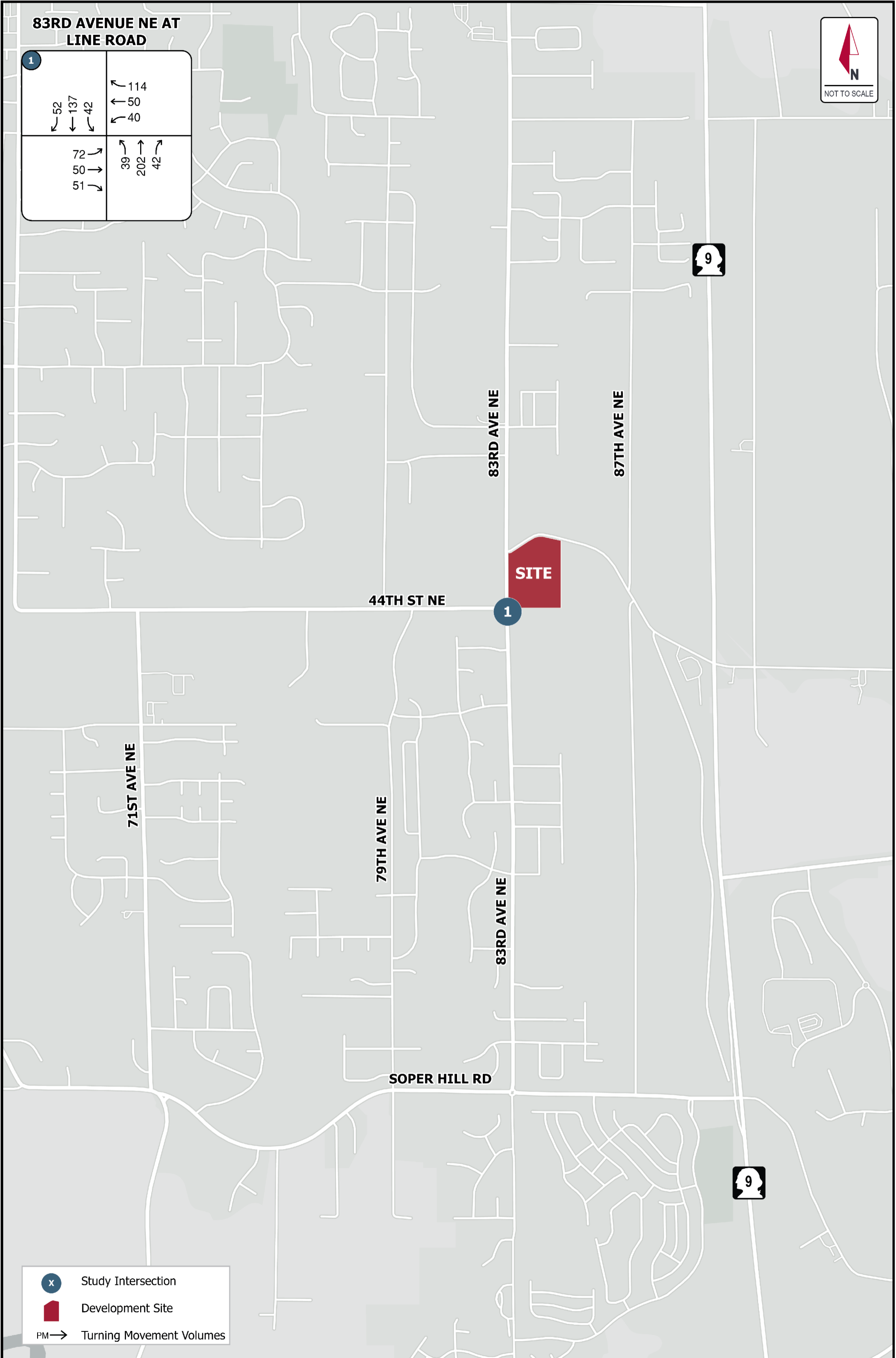

- Study Intersection
- Development Site
- Turning Movement Volumes

FIGURE 9 - 2032 BASELINE TURNING MOVEMENTS
090223146 CORNELIUS LACEY - CITY OF MARYSVILLE

**83RD AVENUE NE AT
LINE ROAD**

1	<p>52 ←</p> <p>137 ←</p> <p>53 ←</p>	<p>121 ↗</p> <p>55 ↑</p> <p>43 ↖</p>
	<p>72 ↗</p> <p>58 →</p> <p>51 ↘</p>	<p>39 ↗</p> <p>202 →</p> <p>48 ↘</p>

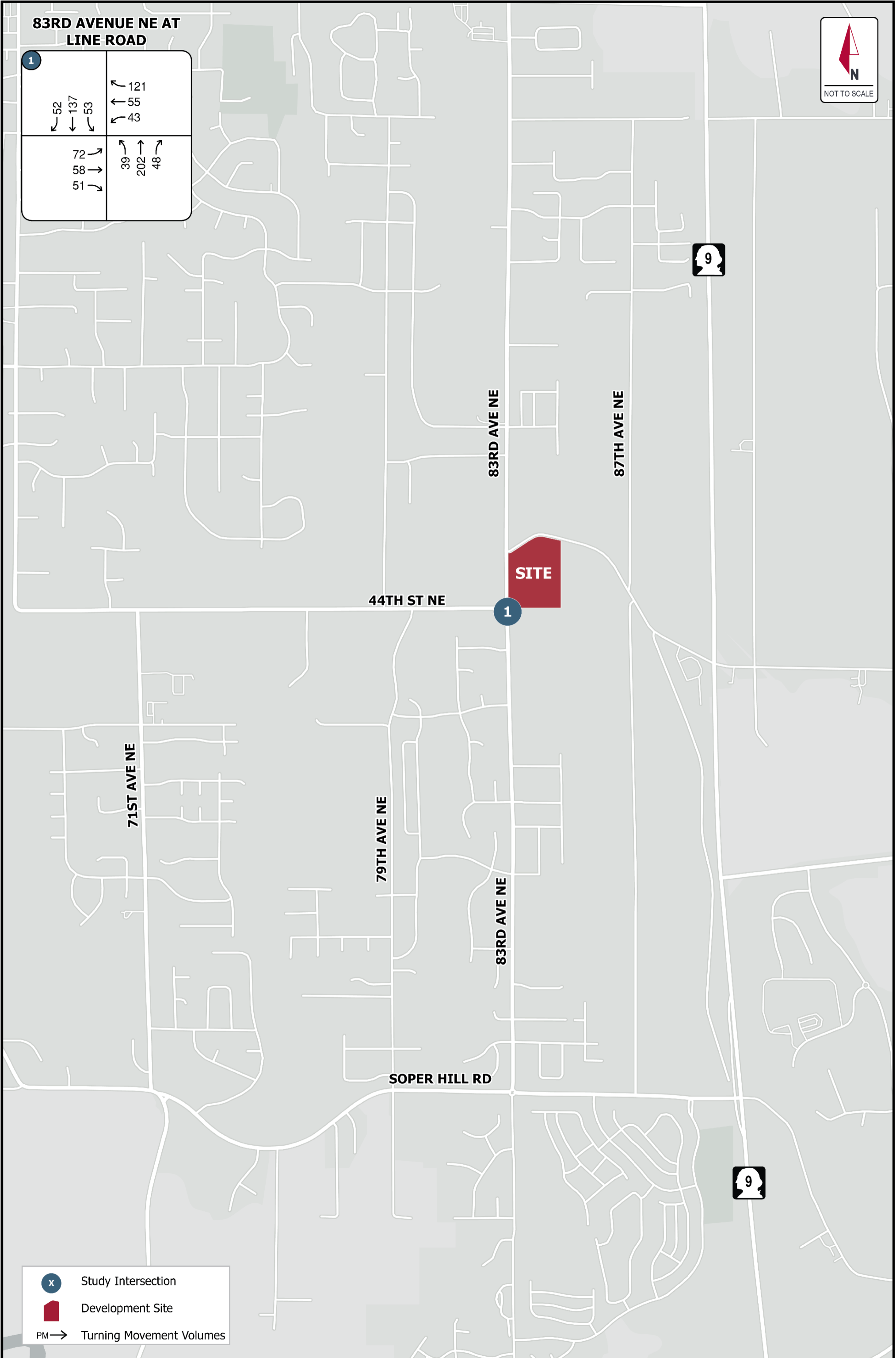

- Study Intersection
- Development Site
- PM → Turning Movement Volumes

FIGURE 10 - 2032 FUTURE TURNING MOVEMENTS
090223146 CORNELIUS LACEY - CITY OF MARYSVILLE

5.2. Level of Service Calculations

The level of service calculations have been performed utilizing the existing channelization, existing intersection control and peak-hour factors and heavy vehicle factors from the 2023 turning movement counts. The level of service summary for the opening-year is included in **Table 5** and the level of service summary for the horizon-year is included in **Table 6** for the PM peak-hour. It should be noted that the future conversion of Sunnyside School Road to a pedestrian trail will remove the east leg extension along 83rd Avenue NE. With this removal the intersection will only be impacted by through traffic and no longer have stop-control delay. The intersection of 83rd Avenue NE at E Sunnyside School Road has therefore been removed from the horizon-year analysis.

Table 5: Level of Service Summary – 2026 Opening-Year

Intersection	Approach	2023 Existing		2026 Baseline		2026 Future w Dev.	
		LOS	Delay	LOS	Delay	LOS	Delay
1: 83 rd Avenue NE at 44 th Street NE	Two-Way Stop Control	B	11.3 sec	B	11.7 sec	B	12.8 sec
2: 83 rd Avenue NE at E Sunnyside School Road	Two-Way Stop Control	B	10.8 sec	B	11.2 sec	B	11.7 sec

Table 6: Level of Service Summary – 2032 Horizon-Year

Intersection	Approach	2023 Existing		2032 Baseline		2032 Future w Dev.	
		LOS	Delay	LOS	Delay	LOS	Delay
1: 83 rd Avenue NE at 44 th Street NE	Two-Way Stop Control	B	11.3 sec	D	25.4 sec	D	29.8 sec

The analysis shows that the study intersections currently operate at LOS B during the PM peak-hour. In the 2026 opening-year baseline and future with development conditions, all study intersections are anticipated to continue operating at LOS B with the Development. In the 2032 horizon-year baseline and future with development conditions, the study intersection is anticipated to operating at LOS D with the Development. The intersection LOS calculations are provided in the **Appendix E**.

6. SITE ACCESS

The Development is proposed to have one access driveway to 83rd Avenue NE and an access that will form the extension of 44th Street NE. The access locations appear to have adequate sight distance, based on preliminary evaluations.

7. TRANSPORTATION IMPACT FEES

The City has interlocal agreements with the County and WSDOT for transportation impact fees. These transportation impact fees are based on the area wide traffic mitigation fee or actual impacts to improvement projects.

7.1. City of Marysville

The City traffic mitigation fees have been calculated using the residential rates of \$6,300 per new single-family unit. The Development is anticipated to consist of 65 new single-family units with credit for the two existing single-family detached units. The City of Marysville traffic mitigation fees for the Development should therefore be \$409,500.00. It is important to note that these calculations do not include a credit for the mobile home unit on the site. Including the credit for that unit would reduce the fees to \$403,200.00.

7.2. Snohomish County

The City and County have an interlocal agreement that provides for the payment of traffic mitigation for impacts to County roadways by City developments. Traffic mitigation fees are based on predetermined area impacts or impacts to actual improvement projects. The only County improvement project in the area is along 88th Street NE, between approximately 44th Drive NE to 66th Drive NE. This improvement project is not anticipated to be impacted by three directional PM peak-hour trips from the Development. County traffic mitigation fees should therefore not be required for the Development.

7.3. Washington State Department of Transportation

The WSDOT mitigation fees are based on impacts to improvement projects identified in the Exhibit C List included in the interlocal agreement between the County and WSDOT. There are not any WSDOT intersections on the Exhibit C List that will be impacted by three directional PM peak-hour trips generated by the Development. WSDOT transportation impact fees should therefore not be required for the Development.

8. CONCLUSIONS

The Development is proposed to consist of 67 single-family detached residential units. The site is currently listed as occupied with two single-family detached units and one mobile home. The Development is anticipated to generate approximately 606 new ADTs with approximately 46 new AM peak-hour trips and 60 new PM peak-hour trips. The Development is anticipated to construct 65 new single-family units. The City traffic mitigation fees for the Development should therefore be \$409,500.00, with fees as low as \$403,200.00 with credit for the mobile home. Neither County nor WSDOT traffic mitigation fees should be required for the Development.

APPENDIX A
SITE PLAN

Call before you Dig
 811
 or
 1-800-642-2444
 or
 digcall.wa.gov



Call before you Dig
 or
 1-800-642-2444
 or
 digcall.wa.gov



MARYSVILLE			LICENSED PROFESSIONAL KIMLEY-HORN & ASSOCIATES, INC. 2023 KIMLEY-HORN AND ASSOCIATES, INC. 1201 THIRD AVENUE SUITE 2500 SEATTLE, WA 98101
WASHINGTON			
DATE	SCALE AS SHOWN		
DESIGNED BY	DRAWN BY		
KHA PROJECT		PROFESSIONAL ENGINEER STATE OF WASHINGTON KIMLEY-HORN & ASSOCIATES, INC.	CHECKED BY DATE
DRXX-XX		REVISIONS NO. DATE BY	

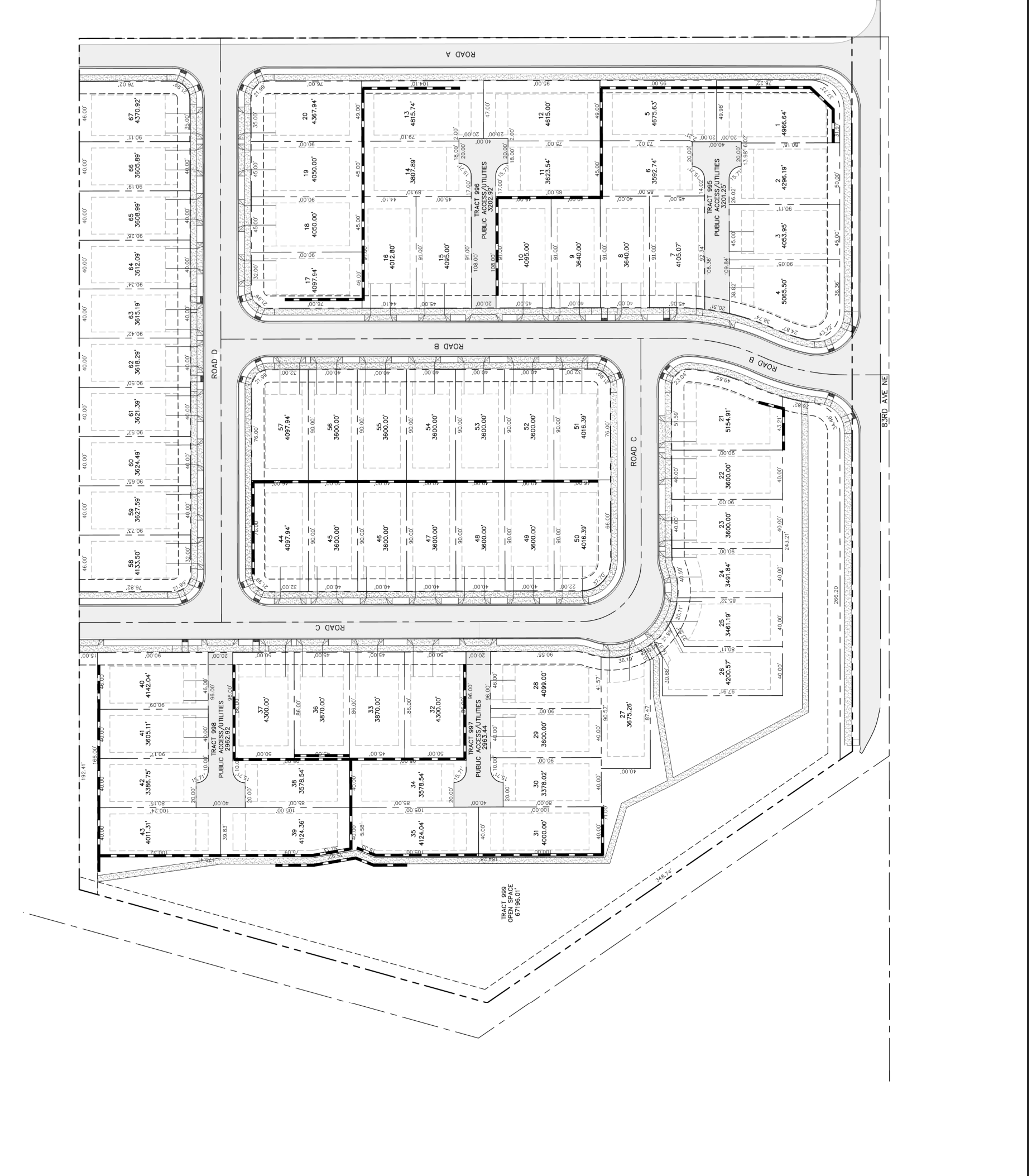

This document, together with the concepts and designs presented herein, is intended only for the specific purpose and client for which it was prepared. Reuse of and improper reliance on this document without written authorization and adoption by Kimley-Horn and Associates, Inc. shall be without liability to Kimley-Horn and Associates, Inc.

APPENDIX B
TRIP GENERATION CALCULATIONS

Cornelius Lacey
090223146

Trip Generation for: Weekday
(a.k.a.): Average Weekday Daily Trips (AWDT)

		NET EXTERNAL TRIPS BY TYPE																		
		IN BOTH DIRECTIONS										DIRECTIONAL ASSIGNMENTS								
LAND USES	VARIABLE	ITE LU code	Gross Trips				Internal Crossover		TOTAL	PASS-BY		DIVERTED LINK		NEW	PASS-BY		DIVERTED LINK		NEW	
			Trip Rate	% IN	% OUT	In+Out (Total)	% of Gross Trips	Trips In+Out (Total)	In+Out (Total)	% of Ext. Trips	In+Out (Total)	% of Ext. Trips	In+Out (Total)	In+Out (Total)	In	Out	In	Out	In	Out
Single-Family Detached Housing	67 units	210	9.43	50%	50%	632	0%	0	632	0%	0	0%	0	632	0	0	0	0	316	316
Single-Family Detached Housing (Removed)	-2 units	210	9.43	50%	50%	-19	0%	0	-19	0%	0	0%	0	-19	0	0	0	0	-10	-9
Mobile Home (Removed)	-1 unit	240	7.12	50%	50%	-7	0%	0	-7	0%	0	0%	0	-7	0	0	0	0	-4	-3
Total						606		0	606		0		0	606	0	0	0	0	302	304

Cornelius Lacey
090223146

Trip Generation for: Weekday, Peak Hour of Adjacent Street Traffic, One Hour between 7 and 9 AM
(a.k.a.): Weekday AM Peak Hour

		NET EXTERNAL TRIPS BY TYPE																		
		IN BOTH DIRECTIONS										DIRECTIONAL ASSIGNMENTS								
LAND USES	VARIABLE	ITE LU code	Gross Trips				Internal Crossover		TOTAL	PASS-BY		DIVERTED LINK		NEW	PASS-BY		DIVERTED LINK		NEW	
			Trip Rate	% IN	% OUT	In+Out (Total)	% of Gross Trips	Trips In+Out (Total)	In+Out (Total)	% of Ext. Trips	In+Out (Total)	% of Ext. Trips	In+Out (Total)	In+Out (Total)	In	Out	In	Out	In	Out
Single-Family Detached Housing	67 units	210	0.70	26%	74%	47	0%	0	47	0%	0	0%	0	47	0	0	0	0	12	35
Single-Family Detached Housing (Removed)	-2 units	210	0.70	26%	74%	-1	0%	0	-1	0%	0	0%	0	-1	0	0	0	0	0	-1
Mobile Home (Removed)	-1 unit	240	0.39	21%	79%	0	0%	0	0	0%	0	0%	0	0	0	0	0	0	0	0
Total						46		0	46		0		0	46	0	0	0	0	12	34

Cornelius Lacey
090223146

Trip Generation for: Weekday, Peak Hour of Adjacent Street Traffic, One Hour between 4 and 6 PM
(a.k.a.): Weekday PM Peak Hour

		NET EXTERNAL TRIPS BY TYPE																		
		IN BOTH DIRECTIONS										DIRECTIONAL ASSIGNMENTS								
LAND USES	VARIABLE	ITE LU code	Gross Trips				Internal Crossover		TOTAL	PASS-BY		DIVERTED LINK		NEW	PASS-BY		DIVERTED LINK		NEW	
			Trip Rate	% IN	% OUT	In+Out (Total)	% of Gross Trips	Trips In+Out (Total)	In+Out (Total)	% of Ext. Trips	In+Out (Total)	% of Ext. Trips	In+Out (Total)	In+Out (Total)	In	Out	In	Out	In	Out
Single-Family Detached Housing	67 units	210	1.00	63%	37%	67	0%	0	67	0%	0	0%	0	67	0	0	0	0	42	25
Single-Family Detached Housing (Removed)	-2 units	210	1.00	63%	37%	-2	0%	0	-2	0%	0	0%	0	-2	0	0	0	0	-1	-1
Mobile Home (Removed)	-1 unit	240	0.58	62%	38%	-1	0%	0	-1	0%	0	0%	0	-1	0	0	0	0	-1	0
Total						64		0	64		0		0	64	0	0	0	0	40	24

APPENDIX C
DISTRIBUTION AND COUNT DATA

WHISKEY RIDGE NORTH - EXISTING



City of Marysville

November 2017

- Marysville City Limits
- Other City Limits
- Urban Growth Boundary
- Tulalip Reservation
- Parks and open space
- Interstate Highway
- State Highway
- Arterial
- Schools



0 2,000 4,000 6,000 Feet

produced by City of Marysville GIS

THE CITY OF MARYSVILLE DISCLAIMS ANY WARRANTY OF MERCHANTABILITY OR WARRANTY OF FITNESS OF THIS DATA FOR ANY PARTICULAR PURPOSE, EITHER EXPRESSED OR IMPLIED. NO REPRESENTATION OR WARRANTY IS MADE CONCERNING THE ACCURACY, CURRENCY, COMPLETENESS OR QUALITY OF DATA DEPICTED. ANY USER OF THIS DATA ASSUMES ALL RESPONSIBILITY FOR USE THEREOF, AND FURTHER AGREES TO HOLD THE CITY OF MARYSVILLE HARMLESS FROM AND AGAINST ANY DAMAGE, LOSS, OR LIABILITY ARISING FROM ANY USE OF THIS DATA.

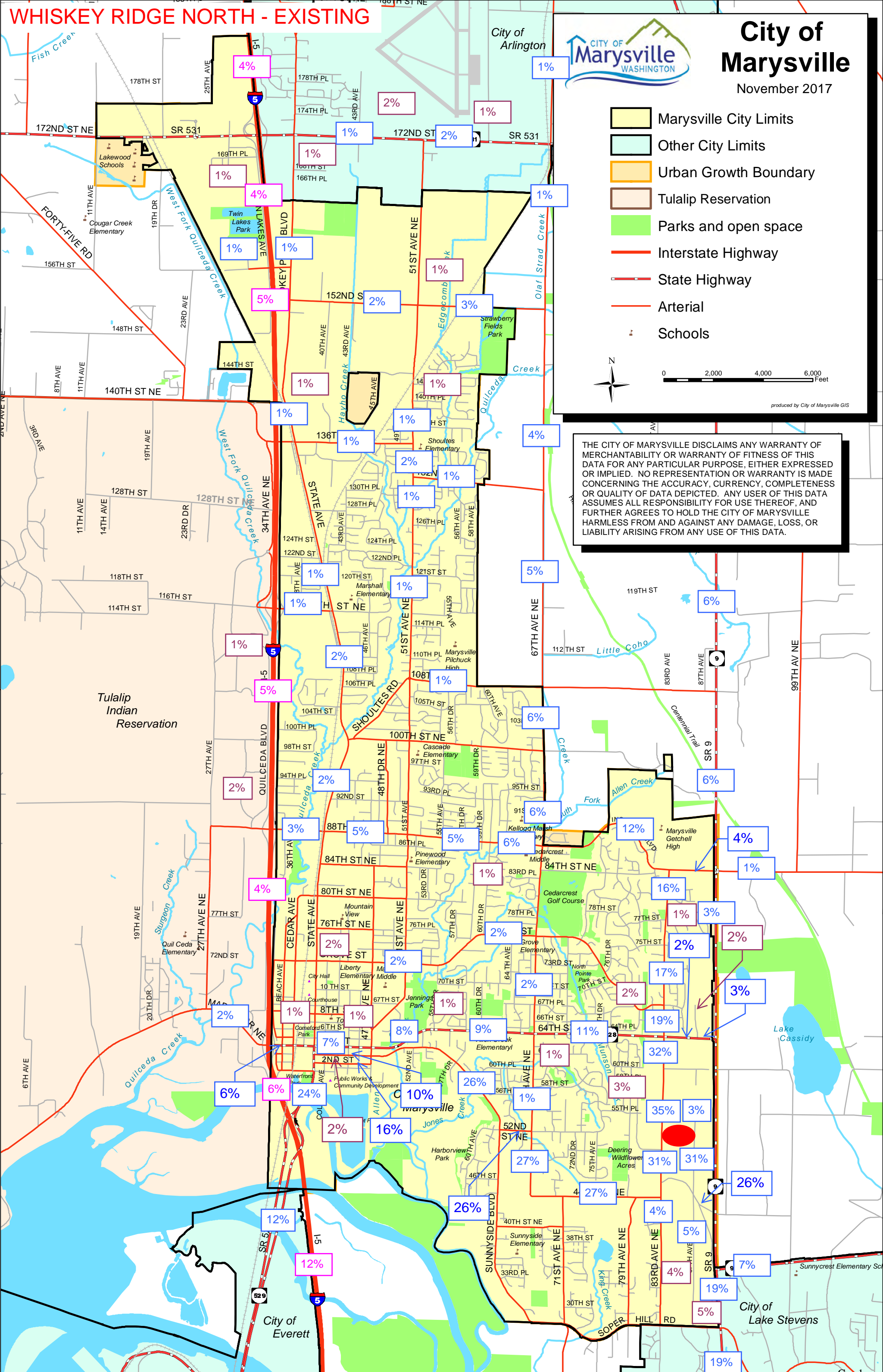

WHISKEY RIDGE NORTH - EXISTING

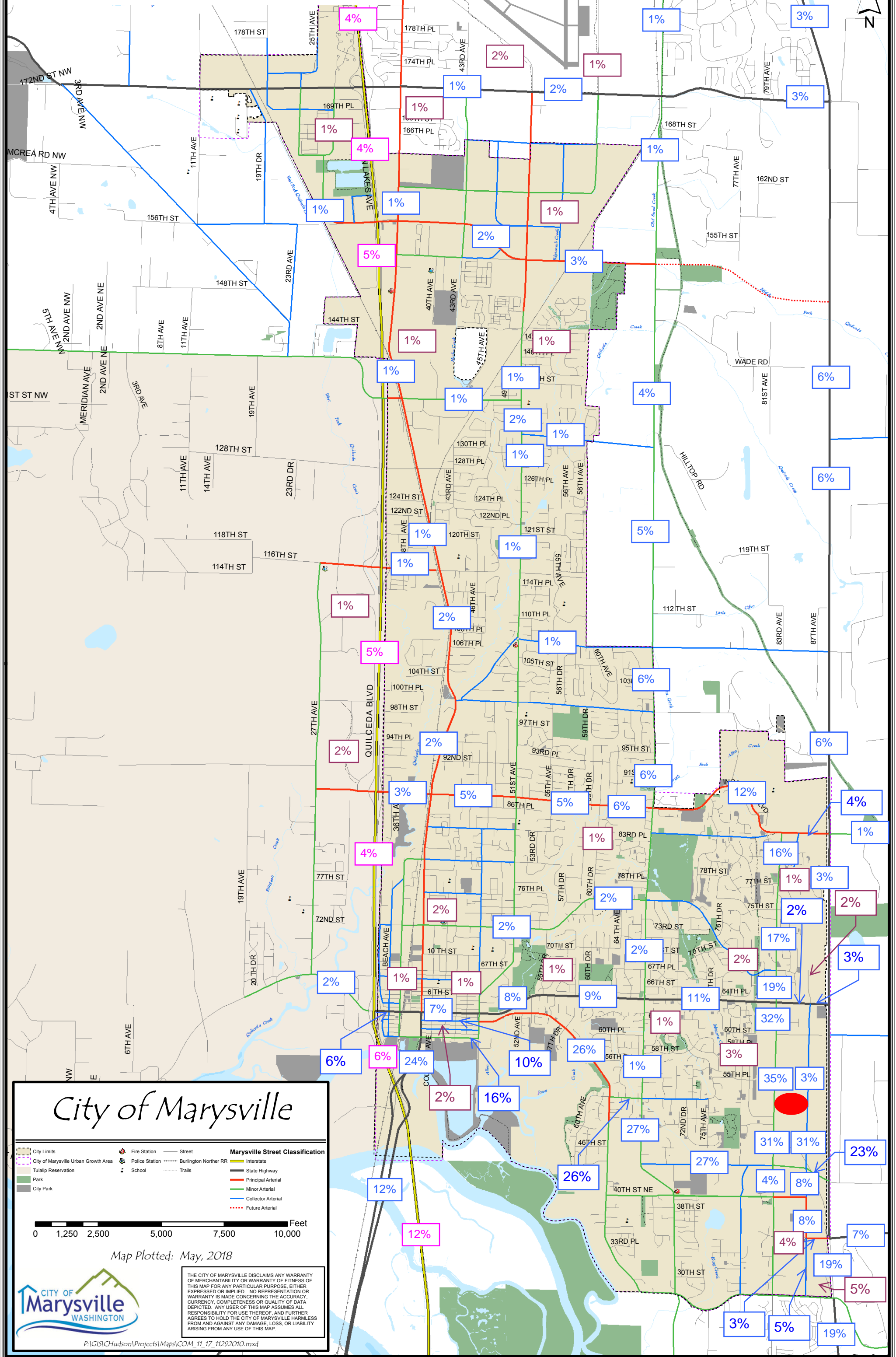

City of Marysville

			Marysville Street Classification

0 1,250 2,500 5,000 7,500 10,000 Feet

Map Plotted: May, 2018

THE CITY OF MARYSVILLE DISCLAIMS ANY WARRANTY OF MERCHANTABILITY OR WARRANTY OF FITNESS OF THIS MAP FOR ANY PARTICULAR PURPOSE, EITHER EXPRESSED OR IMPLIED. NO REPRESENTATION OR WARRANTY IS MADE CONCERNING THE ACCURACY, CURRENCY, COMPLETENESS OR QUALITY OF DATA DEPICTED. ANY USER OF THIS MAP ASSUMES ALL RESPONSIBILITY FOR USE THEREOF, AND FURTHER AGREES TO HOLD THE CITY OF MARYSVILLE HARMLESS FROM AND AGAINST ANY DAMAGE, LOSS, OR LIABILITY ARISING FROM ANY USE OF THIS MAP.

P:\GIS\Hudson\Projects\Maps\COM_11_17_11292010.mxd

WHISKEY RIDGE EAST - EXISTING



City of Marysville

November 2017

- Marysville City Limits
- Other City Limits
- Urban Growth Boundary
- Tulalip Reservation
- Parks and open space
- Interstate Highway
- State Highway
- Arterial
- Schools



0 2,000 4,000 6,000 Feet

produced by City of Marysville GIS

THE CITY OF MARYSVILLE DISCLAIMS ANY WARRANTY OF MERCHANTABILITY OR WARRANTY OF FITNESS OF THIS DATA FOR ANY PARTICULAR PURPOSE, EITHER EXPRESSED OR IMPLIED. NO REPRESENTATION OR WARRANTY IS MADE CONCERNING THE ACCURACY, CURRENCY, COMPLETENESS OR QUALITY OF DATA DEPICTED. ANY USER OF THIS DATA ASSUMES ALL RESPONSIBILITY FOR USE THEREOF, AND FURTHER AGREES TO HOLD THE CITY OF MARYSVILLE HARMLESS FROM AND AGAINST ANY DAMAGE, LOSS, OR LIABILITY ARISING FROM ANY USE OF THIS DATA.

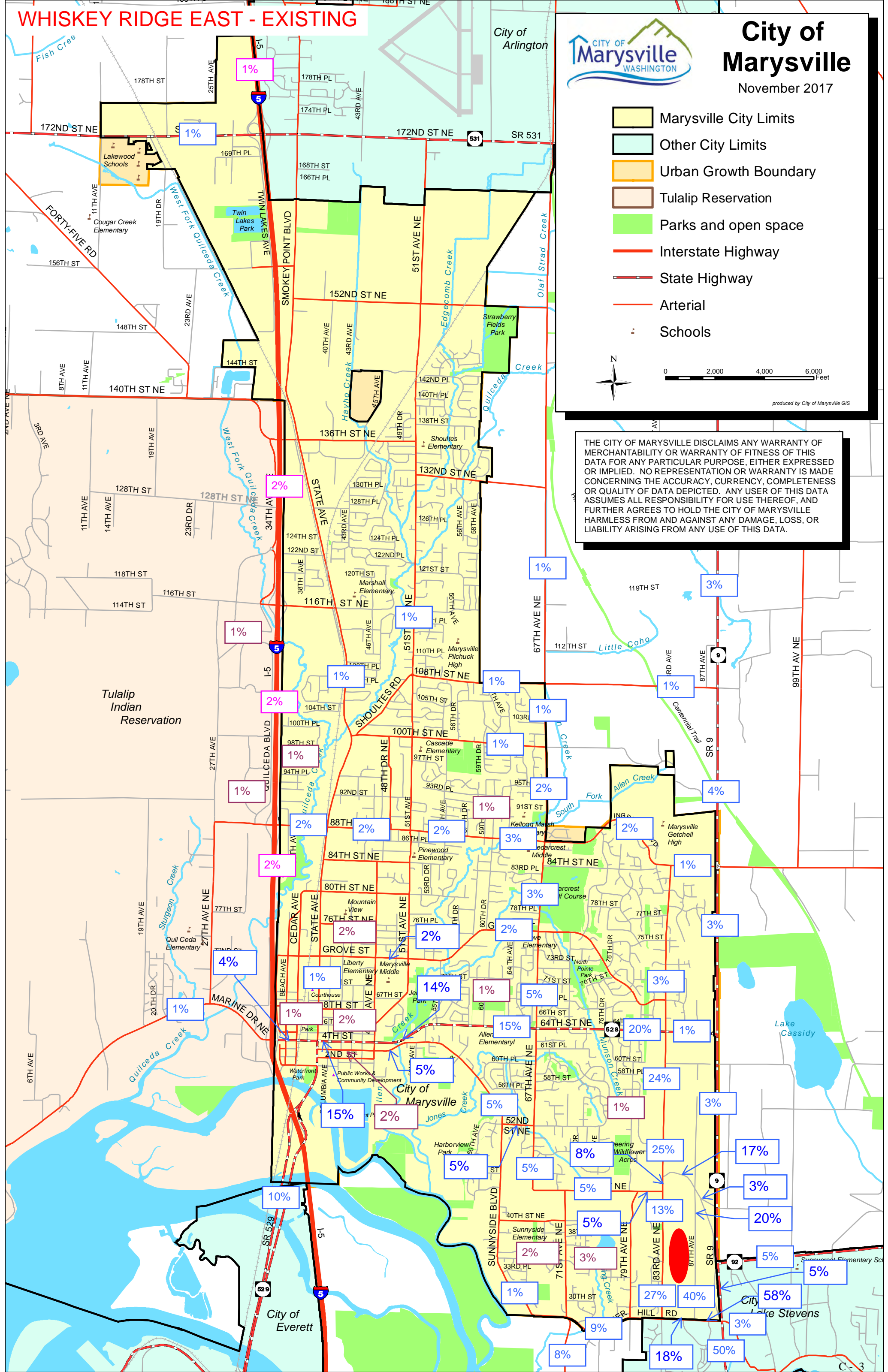

WHISKEY RIDGE WEST - HORIZON

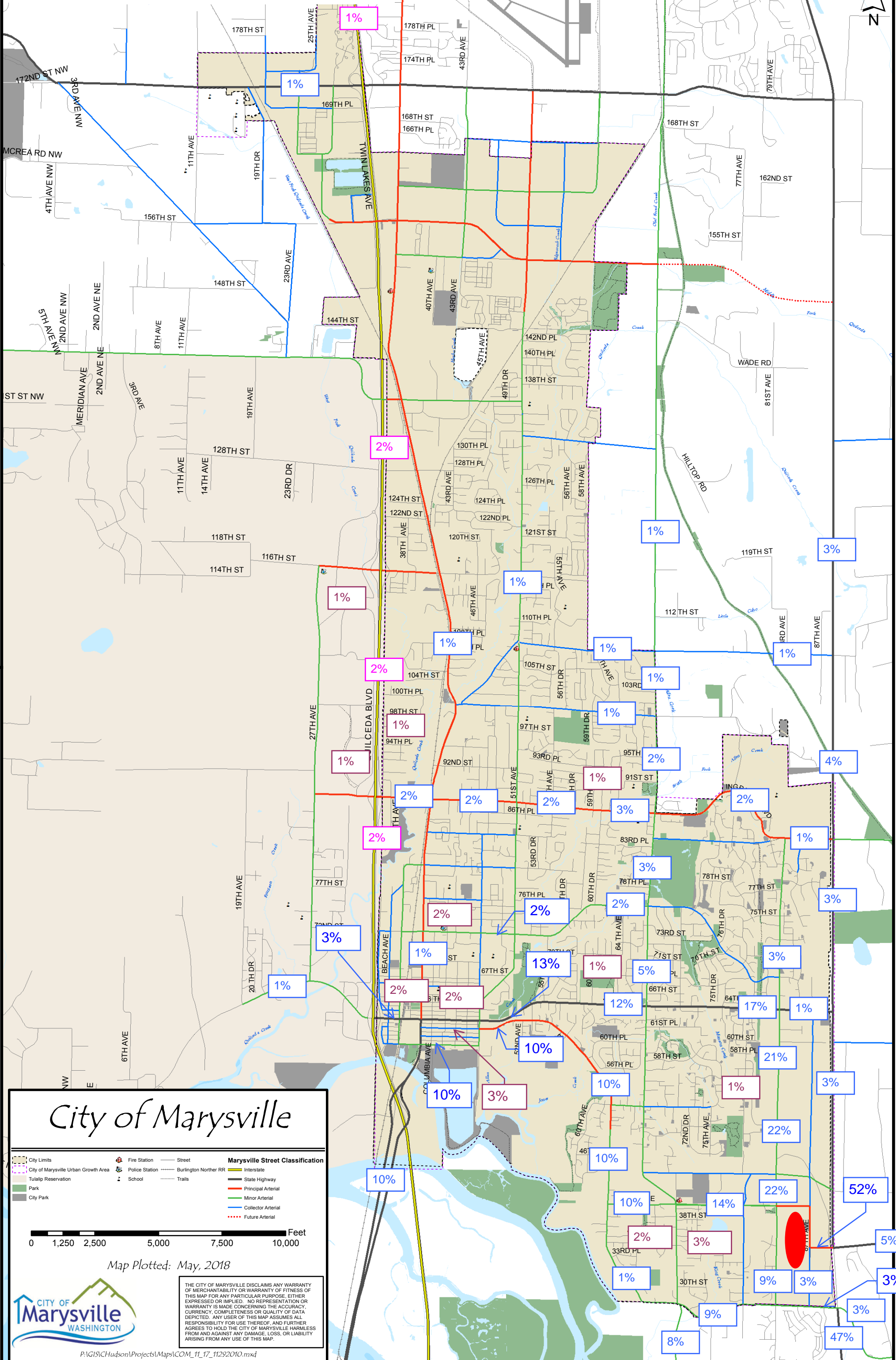

City of Marysville

			Marysville Street Classification

0 1,250 2,500 5,000 7,500 10,000 Feet

Map Plotted: May, 2018

THE CITY OF MARYSVILLE DISCLAIMS ANY WARRANTY OF MERCHANTABILITY OR WARRANTY OF FITNESS OF THIS MAP FOR ANY PARTICULAR PURPOSE, EITHER EXPRESSED OR IMPLIED. NO REPRESENTATION OR WARRANTY IS MADE CONCERNING THE ACCURACY, CURRENCY, COMPLETENESS OR QUALITY OF DATA DEPICTED. ANY USER OF THIS MAP ASSUMES ALL RESPONSIBILITY FOR USE THEREOF, AND FURTHER AGREES TO HOLD THE CITY OF MARYSVILLE HARMLESS FROM AND AGAINST ANY DAMAGE, LOSS, OR LIABILITY ARISING FROM ANY USE OF THIS MAP.

P:\GIS\Hudson\Projects\Maps\COM_11_17_11292010.mxd

83rd Avenue NE @ Line Road/44th Street NE

Marysville, WA

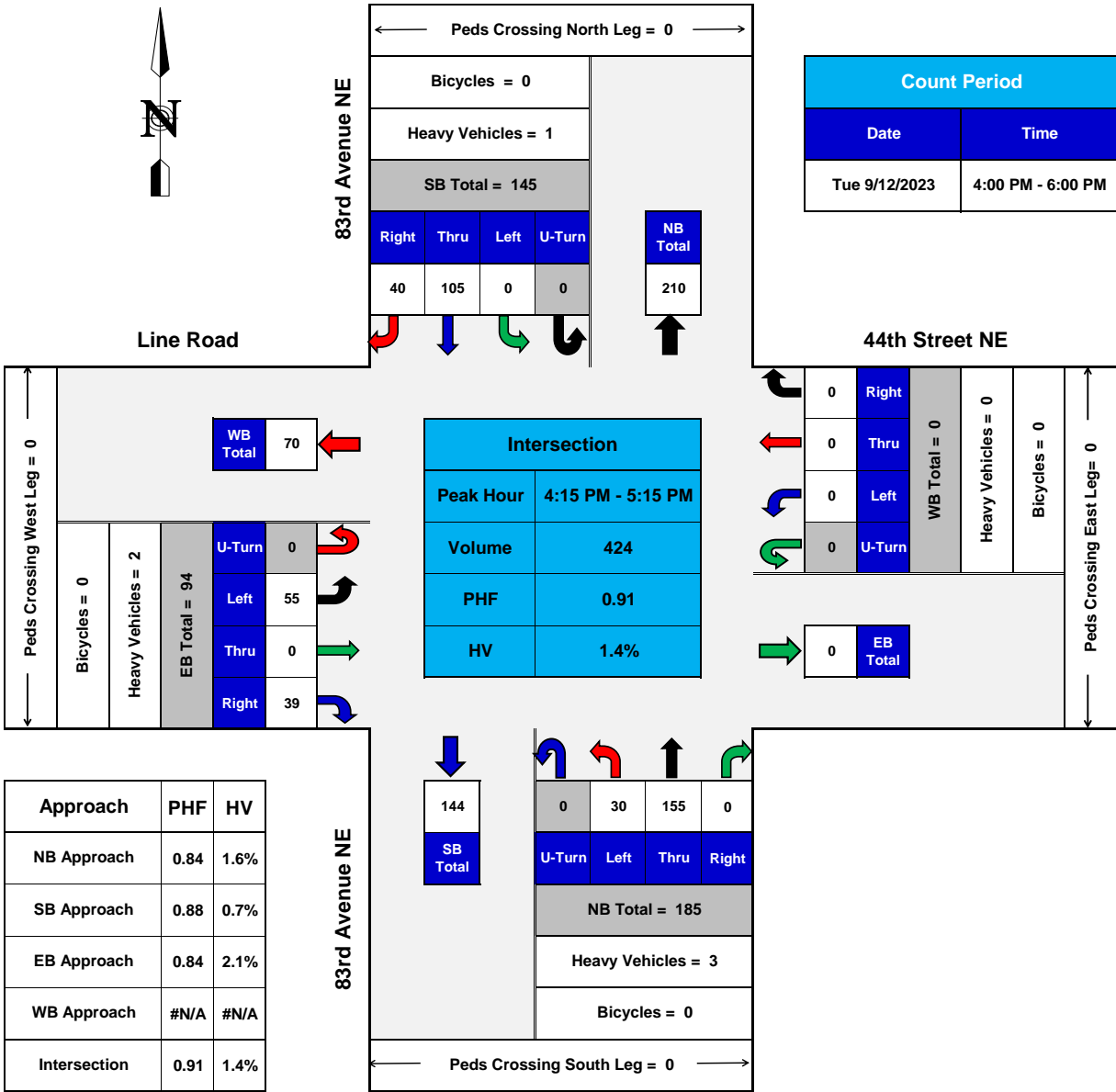

PHF = Peak Hour Factor
HV = Heavy Vehicles

TURNING MOVEMENTS DIAGRAM PEAK HOUR SUMMARY



83rd Avenue NE @ E Sunnyside School Road

Marysville, WA

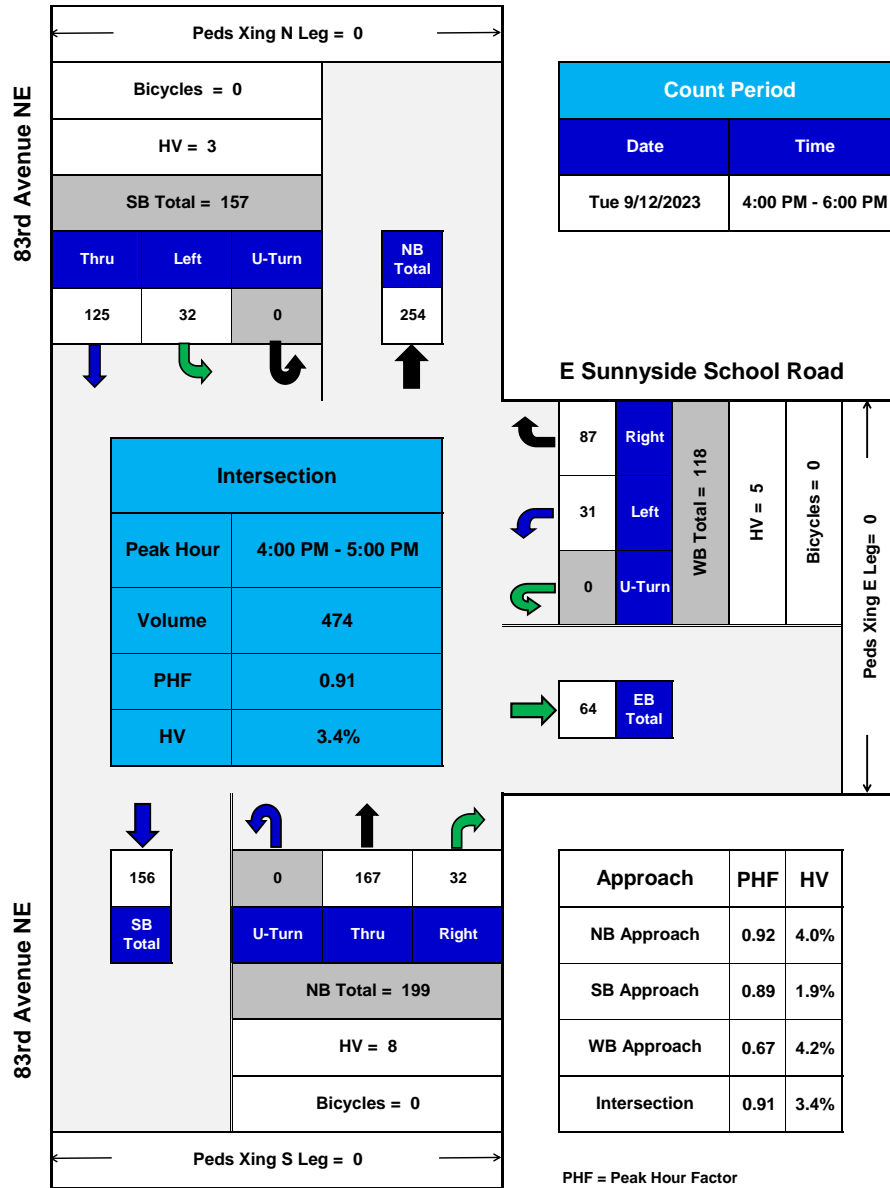

TURNING MOVEMENTS DIAGRAM

PEAK HOUR SUMMARY



APPENDIX D
TURNING MOVEMENT CALCULATIONS

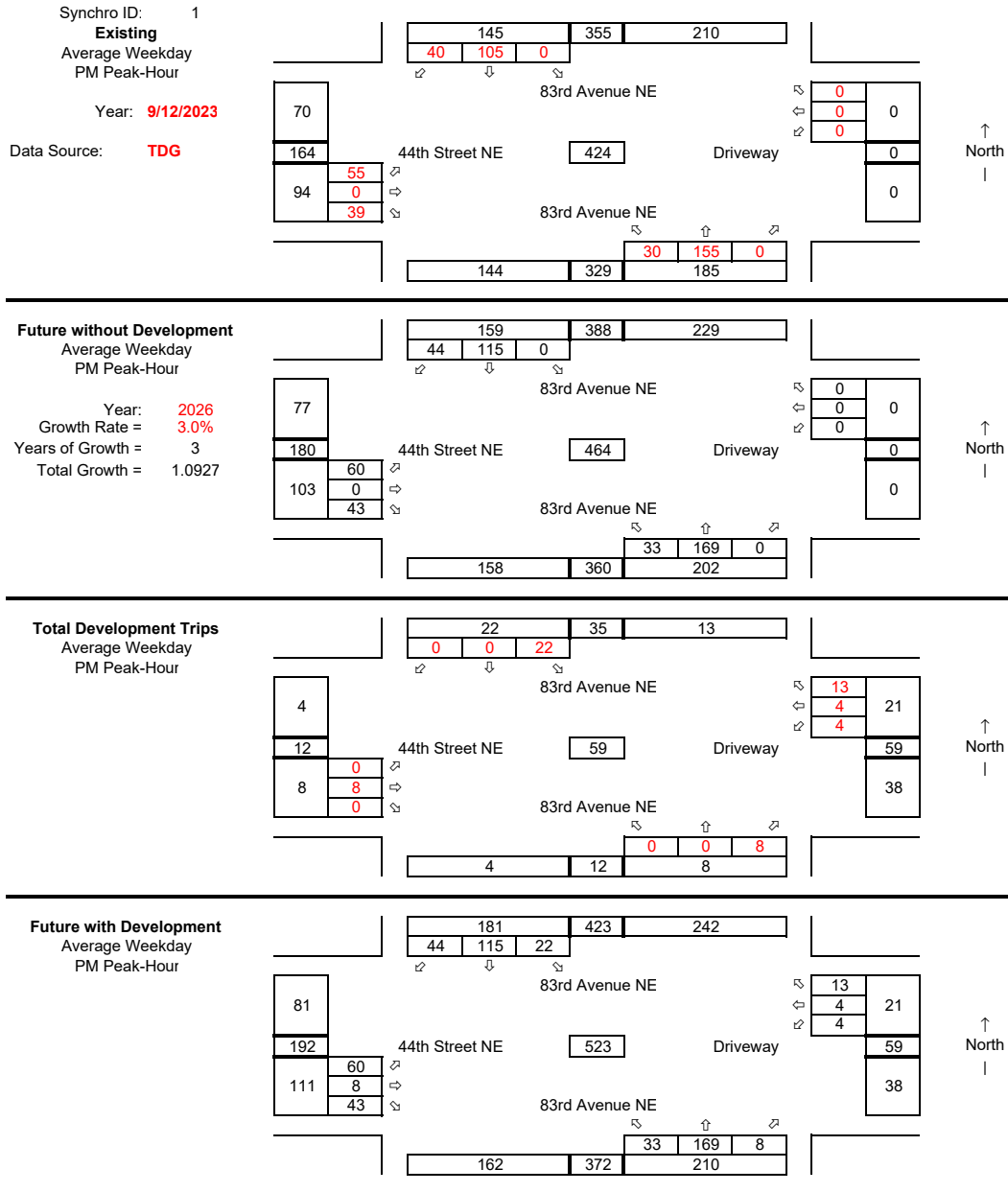

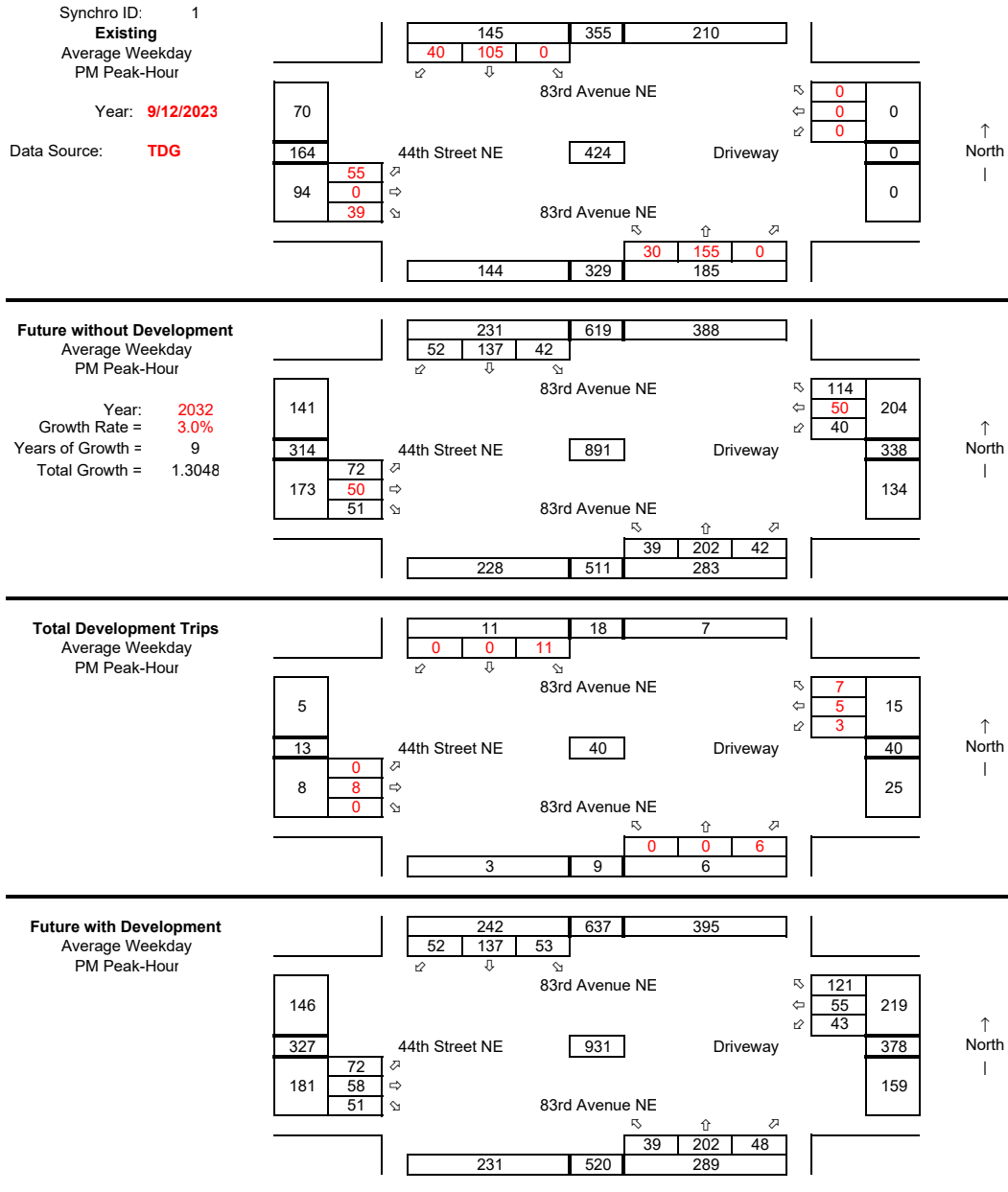

APPENDIX E
LEVEL OF SERVICE CALCULATIONS

HCM 6th TWSC
 1: 83rd Avenue NE & 44th Street NE/Driveway

2023 EXISTING CONDITIONS

Intersection												
Int Delay, s/veh	3											
Movement	EBL	EBT	EBR	WBL	WBT	WBR	NBL	NBT	NBR	SBL	SBT	SBR
Lane Configurations		↔			↔			↔			↔	
Traffic Vol, veh/h	55	0	39	0	0	0	30	155	0	0	105	40
Future Vol, veh/h	55	0	39	0	0	0	30	155	0	0	105	40
Conflicting Peds, #/hr	0	0	0	0	0	0	0	0	0	0	0	0
Sign Control	Stop	Stop	Stop	Stop	Stop	Stop	Free	Free	Free	Free	Free	Free
RT Channelized	-	-	None	-	-	None	-	-	None	-	-	None
Storage Length	-	-	-	-	-	-	-	-	-	-	-	-
Veh in Median Storage, #	-	0	-	-	0	-	-	0	-	-	0	-
Grade, %	-	0	-	-	0	-	-	0	-	-	0	-
Peak Hour Factor	91	91	91	91	91	91	91	91	91	91	91	91
Heavy Vehicles, %	1	1	1	1	1	1	1	1	1	1	1	1
Mvmt Flow	60	0	43	0	0	0	33	170	0	0	115	44

Major/Minor	Minor2		Minor1			Major1		Major2				
Conflicting Flow All	373	373	137	395	395	170	159	0	0	170	0	0
Stage 1	137	137	-	236	236	-	-	-	-	-	-	-
Stage 2	236	236	-	159	159	-	-	-	-	-	-	-
Critical Hdwy	7.11	6.51	6.21	7.11	6.51	6.21	4.11	-	-	4.11	-	-
Critical Hdwy Stg 1	6.11	5.51	-	6.11	5.51	-	-	-	-	-	-	-
Critical Hdwy Stg 2	6.11	5.51	-	6.11	5.51	-	-	-	-	-	-	-
Follow-up Hdwy	3.509	4.009	3.309	3.509	4.009	3.309	2.209	-	-	2.209	-	-
Pot Cap-1 Maneuver	586	559	914	567	543	876	1427	-	-	1413	-	-
Stage 1	869	785	-	769	712	-	-	-	-	-	-	-
Stage 2	769	712	-	846	768	-	-	-	-	-	-	-
Platoon blocked, %								-	-	-	-	-
Mov Cap-1 Maneuver	574	544	914	530	529	876	1427	-	-	1413	-	-
Mov Cap-2 Maneuver	574	544	-	530	529	-	-	-	-	-	-	-
Stage 1	846	785	-	749	693	-	-	-	-	-	-	-
Stage 2	749	693	-	806	768	-	-	-	-	-	-	-

Approach	EB	WB	NB	SB
HCM Control Delay, s	11.3	0	1.2	0
HCM LOS	B	A		

Minor Lane/Major Mvmt	NBL	NBT	NBR	EBLn1	WBLn1	SBL	SBT	SBR
Capacity (veh/h)	1427	-	-	679	-	1413	-	-
HCM Lane V/C Ratio	0.023	-	-	0.152	-	-	-	-
HCM Control Delay (s)	7.6	0	-	11.3	0	0	-	-
HCM Lane LOS	A	A	-	B	A	A	-	-
HCM 95th %tile Q(veh)	0.1	-	-	0.5	-	0	-	-

HCM 6th TWSC
 2: 83rd Avenue NE & E Sunnyside School Road

2023 EXISTING CONDITIONS

Intersection

Int Delay, s/veh	3.2					
Movement	WBL	WBR	NBT	NBR	SBL	SBT
Lane Configurations						
Traffic Vol, veh/h	31	87	167	32	32	125
Future Vol, veh/h	31	87	167	32	32	125
Conflicting Peds, #/hr	0	0	0	0	0	0
Sign Control	Stop	Stop	Free	Free	Free	Free
RT Channelized	-	None	-	None	-	None
Storage Length	0	-	-	-	-	-
Veh in Median Storage, #	0	-	0	-	-	0
Grade, %	0	-	0	-	-	0
Peak Hour Factor	91	91	91	91	91	91
Heavy Vehicles, %	3	3	3	3	3	3
Mvmt Flow	34	96	184	35	35	137

Major/Minor	Minor1	Major1	Major2		
Conflicting Flow All	409	202	0	0	219
Stage 1	202	-	-	-	-
Stage 2	207	-	-	-	-
Critical Hdwy	6.43	6.23	-	-	4.13
Critical Hdwy Stg 1	5.43	-	-	-	-
Critical Hdwy Stg 2	5.43	-	-	-	-
Follow-up Hdwy	3.527	3.327	-	-	2.227
Pot Cap-1 Maneuver	597	836	-	-	1344
Stage 1	830	-	-	-	-
Stage 2	825	-	-	-	-
Platoon blocked, %			-	-	-
Mov Cap-1 Maneuver	580	836	-	-	1344
Mov Cap-2 Maneuver	580	-	-	-	-
Stage 1	830	-	-	-	-
Stage 2	802	-	-	-	-

Approach	WB	NB	SB
HCM Control Delay, s	10.8	0	1.6
HCM LOS	B		

Minor Lane/Major Mvmt	NBT	NBRWBLn1	SBL	SBT
Capacity (veh/h)	-	-	749	1344
HCM Lane V/C Ratio	-	-	0.173	0.026
HCM Control Delay (s)	-	-	10.8	7.8
HCM Lane LOS	-	-	B	A
HCM 95th %tile Q(veh)	-	-	0.6	0.1

HCM 6th TWSC
 1: 83rd Avenue NE & 44th Street NE/Driveway

2026 BASELINE CONDITIONS

Intersection												
Int Delay, s/veh	3.1											
Movement	EBL	EBT	EBR	WBL	WBT	WBR	NBL	NBT	NBR	SBL	SBT	SBR
Lane Configurations		↔			↔			↔			↔	
Traffic Vol, veh/h	60	0	43	0	0	0	33	169	0	0	115	44
Future Vol, veh/h	60	0	43	0	0	0	33	169	0	0	115	44
Conflicting Peds, #/hr	0	0	0	0	0	0	0	0	0	0	0	0
Sign Control	Stop	Stop	Stop	Stop	Stop	Stop	Free	Free	Free	Free	Free	Free
RT Channelized	-	-	None	-	-	None	-	-	None	-	-	None
Storage Length	-	-	-	-	-	-	-	-	-	-	-	-
Veh in Median Storage, #	-	0	-	-	0	-	-	0	-	-	0	-
Grade, %	-	0	-	-	0	-	-	0	-	-	0	-
Peak Hour Factor	91	91	91	91	91	91	91	91	91	91	91	91
Heavy Vehicles, %	1	1	1	1	1	1	1	1	1	1	1	1
Mvmt Flow	66	0	47	0	0	0	36	186	0	0	126	48

Major/Minor	Minor2		Minor1			Major1		Major2				
Conflicting Flow All	408	408	150	432	432	186	174	0	0	186	0	0
Stage 1	150	150	-	258	258	-	-	-	-	-	-	-
Stage 2	258	258	-	174	174	-	-	-	-	-	-	-
Critical Hdwy	7.11	6.51	6.21	7.11	6.51	6.21	4.11	-	-	4.11	-	-
Critical Hdwy Stg 1	6.11	5.51	-	6.11	5.51	-	-	-	-	-	-	-
Critical Hdwy Stg 2	6.11	5.51	-	6.11	5.51	-	-	-	-	-	-	-
Follow-up Hdwy	3.509	4.009	3.309	3.509	4.009	3.309	2.209	-	-	2.209	-	-
Pot Cap-1 Maneuver	555	534	899	536	518	859	1409	-	-	1395	-	-
Stage 1	855	775	-	749	696	-	-	-	-	-	-	-
Stage 2	749	696	-	830	757	-	-	-	-	-	-	-
Platoon blocked, %								-	-	-	-	-
Mov Cap-1 Maneuver	543	519	899	497	503	859	1409	-	-	1395	-	-
Mov Cap-2 Maneuver	543	519	-	497	503	-	-	-	-	-	-	-
Stage 1	831	775	-	728	677	-	-	-	-	-	-	-
Stage 2	728	677	-	786	757	-	-	-	-	-	-	-

Approach	EB	WB	NB	SB
HCM Control Delay, s	11.7	0	1.2	0
HCM LOS	B	A		

Minor Lane/Major Mvmt	NBL	NBT	NBR	EBLn1WBLn1	SBL	SBT	SBR
Capacity (veh/h)	1409	-	-	651	-	1395	-
HCM Lane V/C Ratio	0.026	-	-	0.174	-	-	-
HCM Control Delay (s)	7.6	0	-	11.7	0	0	-
HCM Lane LOS	A	A	-	B	A	A	-
HCM 95th %tile Q(veh)	0.1	-	-	0.6	-	0	-

HCM 6th TWSC
 2: 83rd Avenue NE & E Sunnyside School Road

2026 BASELINE CONDITIONS

Intersection

Int Delay, s/veh	3.3					
Movement	WBL	WBR	NBT	NBR	SBL	SBT
Lane Configurations						
Traffic Vol, veh/h	34	95	182	35	35	137
Future Vol, veh/h	34	95	182	35	35	137
Conflicting Peds, #/hr	0	0	0	0	0	0
Sign Control	Stop	Stop	Free	Free	Free	Free
RT Channelized	-	None	-	None	-	None
Storage Length	0	-	-	-	-	-
Veh in Median Storage, #	0	-	0	-	-	0
Grade, %	0	-	0	-	-	0
Peak Hour Factor	91	91	91	91	91	91
Heavy Vehicles, %	3	3	3	3	3	3
Mvmt Flow	37	104	200	38	38	151

Major/Minor	Minor1	Major1	Major2		
Conflicting Flow All	446	219	0	0	238
Stage 1	219	-	-	-	-
Stage 2	227	-	-	-	-
Critical Hdwy	6.43	6.23	-	-	4.13
Critical Hdwy Stg 1	5.43	-	-	-	-
Critical Hdwy Stg 2	5.43	-	-	-	-
Follow-up Hdwy	3.527	3.327	-	-	2.227
Pot Cap-1 Maneuver	568	818	-	-	1323
Stage 1	815	-	-	-	-
Stage 2	808	-	-	-	-
Platoon blocked, %					
Mov Cap-1 Maneuver	550	818	-	-	1323
Mov Cap-2 Maneuver	550	-	-	-	-
Stage 1	815	-	-	-	-
Stage 2	783	-	-	-	-

Approach	WB	NB	SB
HCM Control Delay, s	11.2	0	1.6
HCM LOS	B		

Minor Lane/Major Mvmt	NBT	NBRWBLn1	SBL	SBT
Capacity (veh/h)	-	-	725	1323
HCM Lane V/C Ratio	-	-	0.196	0.029
HCM Control Delay (s)	-	-	11.2	7.8
HCM Lane LOS	-	-	B	A
HCM 95th %tile Q(veh)	-	-	0.7	0.1

HCM 6th TWSC

1: 83rd Avenue NE & 44th Street NE/Driveway

2026 FUTURE WITH DEVELOPMENT CONDITIONS

Intersection

Int Delay, s/veh	3.9											
Movement	EBL	EBT	EBR	WBL	WBT	WBR	NBL	NBT	NBR	SBL	SBT	SBR
Lane Configurations		↔			↔			↔			↔	
Traffic Vol, veh/h	60	8	43	4	4	13	33	169	8	22	115	44
Future Vol, veh/h	60	8	43	4	4	13	33	169	8	22	115	44
Conflicting Peds, #/hr	0	0	0	0	0	0	0	0	0	0	0	0
Sign Control	Stop	Stop	Stop	Stop	Stop	Stop	Free	Free	Free	Free	Free	Free
RT Channelized	-	-	None	-	-	None	-	-	None	-	-	None
Storage Length	-	-	-	-	-	-	-	-	-	-	-	-
Veh in Median Storage, #	-	0	-	-	0	-	-	0	-	-	0	-
Grade, %	-	0	-	-	0	-	-	0	-	-	0	-
Peak Hour Factor	91	91	91	91	91	91	91	91	91	91	91	91
Heavy Vehicles, %	1	1	1	1	1	1	1	1	1	1	1	1
Mvmt Flow	66	9	47	4	4	14	36	186	9	24	126	48

Major/Minor	Minor2		Minor1			Major1		Major2				
Conflicting Flow All	470	465	150	489	485	191	174	0	0	195	0	0
Stage 1	198	198	-	263	263	-	-	-	-	-	-	-
Stage 2	272	267	-	226	222	-	-	-	-	-	-	-
Critical Hdwy	7.11	6.51	6.21	7.11	6.51	6.21	4.11	-	-	4.11	-	-
Critical Hdwy Stg 1	6.11	5.51	-	6.11	5.51	-	-	-	-	-	-	-
Critical Hdwy Stg 2	6.11	5.51	-	6.11	5.51	-	-	-	-	-	-	-
Follow-up Hdwy	3.509	4.009	3.309	3.509	4.009	3.309	2.209	-	-	2.209	-	-
Pot Cap-1 Maneuver	505	496	899	491	483	853	1409	-	-	1384	-	-
Stage 1	806	739	-	744	693	-	-	-	-	-	-	-
Stage 2	736	690	-	779	722	-	-	-	-	-	-	-
Platoon blocked, %								-	-	-	-	-
Mov Cap-1 Maneuver	475	473	899	442	460	853	1409	-	-	1384	-	-
Mov Cap-2 Maneuver	475	473	-	442	460	-	-	-	-	-	-	-
Stage 1	783	725	-	722	673	-	-	-	-	-	-	-
Stage 2	698	670	-	715	708	-	-	-	-	-	-	-

Approach	EB		WB			NB		SB			
HCM Control Delay, s	12.8		10.9			1.2		0.9			
HCM LOS	B		B								

Minor Lane/Major Mvmt	NBL	NBT	NBR	EBLn1	WBLn1	SBL	SBT	SBR
Capacity (veh/h)	1409	-	-	581	637	1384	-	-
HCM Lane V/C Ratio	0.026	-	-	0.21	0.036	0.017	-	-
HCM Control Delay (s)	7.6	0	-	12.8	10.9	7.6	0	-
HCM Lane LOS	A	A	-	B	B	A	A	-
HCM 95th %tile Q(veh)	0.1	-	-	0.8	0.1	0.1	-	-

HCM 6th TWSC
 2: 83rd Avenue NE & E Sunnyside School Road

2026 FUTURE WITH DEVELOPMENT CONDITIONS

Intersection

Int Delay, s/veh	3.5					
Movement	WBL	WBR	NBT	NBR	SBL	SBT
Lane Configurations	W	R	T	R	L	T
Traffic Vol, veh/h	45	95	189	41	35	148
Future Vol, veh/h	45	95	189	41	35	148
Conflicting Peds, #/hr	0	0	0	0	0	0
Sign Control	Stop	Stop	Free	Free	Free	Free
RT Channelized	-	None	-	None	-	None
Storage Length	0	-	-	-	-	-
Veh in Median Storage, #	0	-	0	-	-	0
Grade, %	0	-	0	-	-	0
Peak Hour Factor	91	91	91	91	91	91
Heavy Vehicles, %	3	3	3	3	3	3
Mvmt Flow	49	104	208	45	38	163

Major/Minor	Minor1	Major1	Major2		
Conflicting Flow All	470	231	0	0	253
Stage 1	231	-	-	-	-
Stage 2	239	-	-	-	-
Critical Hdwy	6.43	6.23	-	-	4.13
Critical Hdwy Stg 1	5.43	-	-	-	-
Critical Hdwy Stg 2	5.43	-	-	-	-
Follow-up Hdwy	3.527	3.327	-	-	2.227
Pot Cap-1 Maneuver	550	806	-	-	1306
Stage 1	805	-	-	-	-
Stage 2	798	-	-	-	-
Platoon blocked, %					
Mov Cap-1 Maneuver	532	806	-	-	1306
Mov Cap-2 Maneuver	532	-	-	-	-
Stage 1	805	-	-	-	-
Stage 2	772	-	-	-	-

Approach	WB	NB	SB
HCM Control Delay, s	11.7	0	1.5
HCM LOS	B		

Minor Lane/Major Mvmt	NBT	NBRWBLn1	SBL	SBT
Capacity (veh/h)	-	-	692	1306
HCM Lane V/C Ratio	-	-	0.222	0.029
HCM Control Delay (s)	-	-	11.7	7.8
HCM Lane LOS	-	-	B	A
HCM 95th %tile Q(veh)	-	-	0.8	0.1

HCM 6th TWSC
 1: 83rd Avenue NE & 44th Street NE/Driveway

2032 BASELINE CONDITIONS

Intersection												
Int Delay, s/veh	9.8											
Movement	EBL	EBT	EBR	WBL	WBT	WBR	NBL	NBT	NBR	SBL	SBT	SBR
Lane Configurations		↕			↕			↕			↕	
Traffic Vol, veh/h	72	50	51	40	50	114	39	202	42	42	137	52
Future Vol, veh/h	72	50	51	40	50	114	39	202	42	42	137	52
Conflicting Peds, #/hr	0	0	0	0	0	0	0	0	0	0	0	0
Sign Control	Stop	Stop	Stop	Stop	Stop	Stop	Free	Free	Free	Free	Free	Free
RT Channelized	-	-	None	-	-	None	-	-	None	-	-	None
Storage Length	-	-	-	-	-	-	-	-	-	-	-	-
Veh in Median Storage, #	-	0	-	-	0	-	-	0	-	-	0	-
Grade, %	-	0	-	-	0	-	-	0	-	-	0	-
Peak Hour Factor	91	91	91	91	91	91	91	91	91	91	91	91
Heavy Vehicles, %	1	1	1	1	1	1	1	1	1	1	1	1
Mvmt Flow	79	55	56	44	55	125	43	222	46	46	151	57

Major/Minor	Minor2		Minor1			Major1			Major2			
Conflicting Flow All	693	626	180	658	631	245	208	0	0	268	0	0
Stage 1	272	272	-	331	331	-	-	-	-	-	-	-
Stage 2	421	354	-	327	300	-	-	-	-	-	-	-
Critical Hdwy	7.11	6.51	6.21	7.11	6.51	6.21	4.11	-	-	4.11	-	-
Critical Hdwy Stg 1	6.11	5.51	-	6.11	5.51	-	-	-	-	-	-	-
Critical Hdwy Stg 2	6.11	5.51	-	6.11	5.51	-	-	-	-	-	-	-
Follow-up Hdwy	3.509	4.009	3.309	3.509	4.009	3.309	2.209	-	-	2.209	-	-
Pot Cap-1 Maneuver	359	402	865	379	399	796	1369	-	-	1302	-	-
Stage 1	736	686	-	684	647	-	-	-	-	-	-	-
Stage 2	612	632	-	688	667	-	-	-	-	-	-	-
Platoon blocked, %								-	-	-	-	-
Mov Cap-1 Maneuver	253	371	865	296	369	796	1369	-	-	1302	-	-
Mov Cap-2 Maneuver	253	371	-	296	369	-	-	-	-	-	-	-
Stage 1	709	659	-	659	623	-	-	-	-	-	-	-
Stage 2	453	609	-	566	640	-	-	-	-	-	-	-

Approach	EB		WB			NB			SB		
HCM Control Delay, s	25.4		18.2			1.1			1.4		
HCM LOS	D		C								

Minor Lane/Major Mvmt	NBL	NBT	NBR	EBLn1	WBLn1	SBL	SBT	SBR
Capacity (veh/h)	1369	-	-	362	493	1302	-	-
HCM Lane V/C Ratio	0.031	-	-	0.525	0.455	0.035	-	-
HCM Control Delay (s)	7.7	0	-	25.4	18.2	7.9	0	-
HCM Lane LOS	A	A	-	D	C	A	A	-
HCM 95th %tile Q(veh)	0.1	-	-	2.9	2.3	0.1	-	-

HCM 6th TWSC

1: 83rd Avenue NE & 44th Street NE/Driveway

2032 FUTURE WITH DEVELOPMENT CONDITIONS

Intersection

Int Delay, s/veh	11.4											
Movement	EBL	EBT	EBR	WBL	WBT	WBR	NBL	NBT	NBR	SBL	SBT	SBR
Lane Configurations		↕			↕			↕			↕	
Traffic Vol, veh/h	72	58	51	43	55	121	39	202	48	53	137	52
Future Vol, veh/h	72	58	51	43	55	121	39	202	48	53	137	52
Conflicting Peds, #/hr	0	0	0	0	0	0	0	0	0	0	0	0
Sign Control	Stop	Stop	Stop	Stop	Stop	Stop	Free	Free	Free	Free	Free	Free
RT Channelized	-	-	None	-	-	None	-	-	None	-	-	None
Storage Length	-	-	-	-	-	-	-	-	-	-	-	-
Veh in Median Storage, #	-	0	-	-	0	-	-	0	-	-	0	-
Grade, %	-	0	-	-	0	-	-	0	-	-	0	-
Peak Hour Factor	91	91	91	91	91	91	91	91	91	91	91	91
Heavy Vehicles, %	1	1	1	1	1	1	1	1	1	1	1	1
Mvmt Flow	79	64	56	47	60	133	43	222	53	58	151	57

Major/Minor	Minor2		Minor1			Major1		Major2				
Conflicting Flow All	727	657	180	691	659	249	208	0	0	275	0	0
Stage 1	296	296	-	335	335	-	-	-	-	-	-	-
Stage 2	431	361	-	356	324	-	-	-	-	-	-	-
Critical Hdwy	7.11	6.51	6.21	7.11	6.51	6.21	4.11	-	-	4.11	-	-
Critical Hdwy Stg 1	6.11	5.51	-	6.11	5.51	-	-	-	-	-	-	-
Critical Hdwy Stg 2	6.11	5.51	-	6.11	5.51	-	-	-	-	-	-	-
Follow-up Hdwy	3.509	4.009	3.309	3.509	4.009	3.309	2.209	-	-	2.209	-	-
Pot Cap-1 Maneuver	341	386	865	360	385	792	1369	-	-	1294	-	-
Stage 1	715	670	-	681	644	-	-	-	-	-	-	-
Stage 2	605	628	-	664	651	-	-	-	-	-	-	-
Platoon blocked, %								-	-	-	-	-
Mov Cap-1 Maneuver	231	353	865	271	352	792	1369	-	-	1294	-	-
Mov Cap-2 Maneuver	231	353	-	271	352	-	-	-	-	-	-	-
Stage 1	689	636	-	656	620	-	-	-	-	-	-	-
Stage 2	438	605	-	530	618	-	-	-	-	-	-	-

Approach	EB		WB			NB		SB			
HCM Control Delay, s	29.8		20.6			1		1.7			
HCM LOS	D		C								

Minor Lane/Major Mvmt	NBL	NBT	NBR	EBLn1	WBLn1	SBL	SBT	SBR
Capacity (veh/h)	1369	-	-	338	468	1294	-	-
HCM Lane V/C Ratio	0.031	-	-	0.588	0.514	0.045	-	-
HCM Control Delay (s)	7.7	0	-	29.8	20.6	7.9	0	-
HCM Lane LOS	A	A	-	D	C	A	A	-
HCM 95th %tile Q(veh)	0.1	-	-	3.6	2.9	0.1	-	-