

Marysville City Council Meeting**October 12, 2015****7:00 p.m.****City Hall****Call to Order****Invocation****Pledge of Allegiance****Roll Call****Approval of the Agenda****Committee Reports****Presentations**

A. Custody Officer Swearing-in *

B. Proclamation: Declaring October 2015 as Domestic Violence Awareness Month in Marysville *

C. Marysville/Tulalip Recovery Grant Report *

Audience Participation**Approval of Minutes** *(Written Comment Only Accepted from Audience.)*

1. Approval of the September 14, 2015 City Council Meeting Minutes

14. Approval of the September 28, 2015 City Council Meeting Minutes *

Consent

2. Consider Approval of the September 23, 2015 Claims in the Amount of \$903,453.65; Paid by Check Numbers 102798 through 102937 with No Checks Voided

3. Consider Approval of the September 30, 2015 Claims in the Amount of \$740,001.39; Paid by Check Numbers 102938 through 103119 with No Checks Voided

4. Consider Approval of the September 18, 2015 Payroll in the Amount of \$1,065,360.05; Paid by Check Numbers 29273 through 29306

6. Consider Approval of the Professional Services Agreement with MWH Americas, Inc. in the Amount of \$40,850.00 for Engineering Services

7. Consider Accepting the Marysville Regional Pond #2 Project, Starting the 45-Day Lien Filing Period for Project Closeout

9. Consider Approval of the Interlocal Agreement with Snohomish County for Auto Theft Task Force Services

**These items have been added or revised from the materials previously distributed in the packets for the October 5, 2015 Work Session.*

Marysville City Council Meeting

October 12, 2015

7:00 p.m.

City Hall

10A. Consider Approval of the Final Plat Map for Allen Creek Park

10B. Consider Approval of the Sight Distance Easement Associated with the Plat of Allen Creek Park

13. Consider Approval of the October 5, 2015 payroll in the amount \$1,625,588.74; Paid by Check Numbers 29307 through 29340 *

Review Bids

Public Hearings

New Business

5. Consider the JAG/Byrne Grant Local Funds Award in the Amount of \$11,410.00 to Purchase Equipment for the Police Department

8. Consider the Project Agreement with the RCO for the Grant Totaling \$342,369.00 through the ALEA Program for Trail Development Adjacent to the Qwuloolt Restoration Project

11. Consider a **Resolution** Authorizing Termination and Relinquishment of a City Owned Easement on Private Property

12. Consider the Correction of Easement for Purposes of Utilizing a City owned Septic System *

Legal

Mayor's Business

15. Salary Commission Appointments: Amanda Garlock and Tom King *

Staff Business

Call on Councilmembers

Executive Session

A. Litigation

B. Personnel

C. Real Estate

Adjourn

**These items have been added or revised from the materials previously distributed in the packets for the October 5, 2015 Work Session.*

Marysville City Council Meeting

October 12, 2015

7:00 p.m.

City Hall

Special Accommodations: The City of Marysville strives to provide accessible meetings for people with disabilities. Please contact the City Clerk's office at (360) 363-8000 or 1-800-833-6384 (Voice Relay), 1-800-833-6388 (TDD Relay) two days prior to the meeting date if any special accommodations are needed for this meeting.

**These items have been added or revised from the materials previously distributed in the packets for the October 5, 2015 Work Session.*

Update
Index # B



PROCLAMATION

Declaring October 2015 as Domestic Violence Awareness Month in Marysville

WHEREAS, domestic violence is a serious crime that affects people of all races, ages, gender and income levels; and

WHEREAS, domestic violence is widespread and affects more than 4 million Americans each year; and

WHEREAS, one in three Americans have witnessed an incident of domestic violence; and

WHEREAS, children that grow up in violent homes are believed to be abused and neglected at a rate higher than the national average; and

WHEREAS, domestic violence costs the nation billions of dollars annually in medical expenses, police and court costs, shelters, foster care, sick leave, absenteeism, and non-productivity; and

WHEREAS, only a coordinated community effort will put a stop to this heinous crime; and

WHEREAS, Domestic Violence Awareness Month provides an excellent opportunity for citizens to learn more about preventing domestic violence and to show support for the numerous organizations and individuals who provide critical advocacy, services and assistance to victims;

NOW, THEREFORE I, JON NEHRING, MAYOR OF THE CITY OF MARYSVILLE on behalf of the City Council and our community do hereby proclaim October 2015 as

Domestic Violence Awareness Month in Marysville

I encourage all residents of Marysville to work together to eliminate domestic violence from our community.

Under my hand and seal this twelfth day of October, 2015.

THE CITY OF MARYSVILLE

Mayor Jon Nehring

Index #1

Call to Order/Pledge of Allegiance/Roll Call	7:00 p.m.
Approval of the Agenda	Approved
Committee Reports	
Presentations	
Audience Participation	
Approval of Minutes	
Consider Approval of the July 27, 2015 City Council Meeting Minutes	Approved
Consent Agenda	
Consider Approval of the August 20, 2015 Payroll in the Amount of \$937,249.57; Paid by Check Number 29187 through 29228	Approved
Consider Approval of the August 26, 2015 Claims in the Amount of \$1,959,395.65; Paid by Check Numbers 102249 through 102422 with Check Number 101609, 101872, 101881, 101892 & 101899 Voided	Approved
Consider Accepting of the 2015 Pavement Preservation Program with CEMEX Construction Materials Pacific LLC, Starting the 45-Day Lien Filing Period for Project Closeout	Approved
Consider Accepting of the Qwuloolt Fill Site Project, Starting the 45-Day Lien Period for Project Closeout	Approved
Consider Accepting of the 67th Avenue NE Overlay (88th St. NE to 108th St. NE) Project, Starting the 45-Day Lien Filing Period for Project Closeout	Approved
Consider Approval of the Professional Service Agreement with Waste Management Logistics in the Amount of \$56,500.00	Approved
Consider Approval of the Local Agency State Aid Project Prospectus and Local Agency State Funding Agreement with WSDOT thereby Securing Funding for the Grove Street Pedestrian and Bicycle Improvements (State Ave to Cedar Ave) Project	Approved
Consider Approval of the Local Agency State Aid Project Prospectus and Local Agency State Funding Agreement with WSDOT for Marshall Elementary Safe Routes to School Project	Approved
Consider Approval of the Supplement Number 2 to the Professional Services Agreement with HDR Engineering, Inc. for a No Cost Time Extension	Approved
Consider Approval of the Final Plat Approval of Emberly Subdivision along with the Associated Right-of-Way	Approved
Consider Approval of the September 2, 2015 claims in the amount of \$1,094,243.47; Paid by Check Number 102423 through 102588 with No Checks Voided	Approved
Consider Approval of the September 4, 2015 payroll in the amount \$1,608,382.82; Paid by Check Numbers 29230 through 29272 with Check Number 28572 Voided and Reissued with Check Number 29229	Approved
Review Bids	
Public Hearings	
Consider Approval of the Program Year 2014 Consolidated Annual Performance and Evaluation Report and Direct Staff to Provide a Summary of, and Response to any Comments Received during the Public Hearing	Approved

into the Report, and forward to the U.S. Department of Housing and Urban Development	
New Business	
Consider Approval of an Ordinance Amending Section 2.24.030(5) of the Marysville Municipal Code, Establishing Salary for Municipal Court Judge, Provide for Severability; and Effective Date	Approved Ord. No. 2999
Consider Approval of an Ordinance Setting Forth the Basis of the City's Compliance with the Growth Management Act's (GMA) Required Review and Updating of the City's Comprehensive Plan and Development Regulations Under RCW 36.70A.130(5)(A), Repealing the Comprehensive Plan Adopted by Ordinance 2569, and Adopting a New Comprehensive Plan Pursuant to the City's Periodic GMA Comprehensive Plan Amendment and Update Process	Approved Ord. No. 3000
Consider Approval of an Ordinance Amending Section 6.82.173 of the Marysville Municipal Code, Prohibiting the Use of Electronic Cigarettes in Parks; Providing for Severability; and Effective Date	Approved Ord. No. 3001
Consider Approval of a Resolution Declaring Various Equipment Certain Items of Personal Property to Be Surplus and Authorizing the Sale or Disposal Thereof	Approved Res. No. 2380
An Ordinance of the City of Marysville Amending the 2015/2016 Biennial-Budget and Providing for the Increase of Certain Expenditure Items as Budgeted for in Ordinance No. 2972, and Changes in Compensation Levels	Approved Ord. No. 3002
Mayor's Business	
Staff Business	
Call on Councilmembers	
Adjournment	7:50 p.m.

COUNCIL



DRAFT
MINUTES

Regular Meeting
September 14, 2015

Call to Order / Pledge of Allegiance

Mayor Nehring called the meeting to order at 7:00 p.m. Kim Reynolds from Hillside Church gave the invocation, and Mayor Nehring led those present in the Pledge of Allegiance.

Roll Call

Chief Administrative Officer Hirashima gave the roll call. The following staff and councilmembers were in attendance.

- Mayor:** Jon Nehring
- Council:** Steve Muller, Kamille Norton, Jeff Seibert, Michael Stevens, Rob Toyer, Jeff Vaughan, and Donna Wright
- Absent:** None
- Also Present:** Chief Administrative Officer Gloria Hirashima, Finance Director Sandy Langdon, Police Chief Rick Smith, Deputy City Attorney Colin Olivers, Public Works Director Kevin Nielsen, Parks and Recreation Director Jim Ballew, Community Development Director Dave Koenig, Fire Chief Martin McFalls, Associate Planner Angela Gemmer, Planning Assistant Amy Hess, and Recording Secretary Laurie Hugdahl.

Approval of the Agenda

Motion made by Councilmember Toyer, seconded by Councilmember Wright, to approve the agenda. **Motion** passed unanimously (7-0).

Committee Reports

Kamille Norton reported on the September 9 Park Advisory Board meeting. The Board heard a recap of the summer which was very busy and successful. Over 600 kids enjoyed camps. The Board approved the opera house lease and fees structure. They received a report on the golf course and its success. There was also discussion about

DRAFT

the Tuscany Ridge Park updates, a memorial plaque, and the Harborview Point Community Trail Extension Project.

Councilmember Norton then reported on the September 10 Hotel Motel Tax Fund Committee meeting where they received 13 applications for grants. She noted that there were applications for three times the amount of money there was to grant, but the Committee reviewed the applications and made a recommendation. She felt it was a productive meeting and process.

Presentations

Audience Participation

Approval of Minutes

1. Consider Approval of the July 27, 2015 City Council Meeting Minutes

Councilmember Norton stated she would be abstaining as she was not present at the meeting.

Motion made by Councilmember Vaughan, seconded by Councilmember Stevens, to approve the July 27, 2015 City Council Meeting Minutes. **Motion** passed 6-0 with Councilmember Norton abstaining.

Consent

2. Consider Approval of the August 20, 2015 Payroll in the Amount of \$937,249.57; Paid by Check Number 29187 through 29228
3. Consider Approval of the August 26, 2015 Claims in the Amount of \$1,959,395.65; Paid by Check Numbers 102249 through 102422 with Check Number 101609, 101872, 101881, 101892 & 101899 Voided
10. Consider Accepting of the 2015 Pavement Preservation Program with CEMEX Construction Materials Pacific LLC, Starting the 45-Day Lien Filing Period for Project Closeout
11. Consider Accepting of the Qwuloolt Fill Site Project, Starting the 45-Day Lien Period for Project Closeout
12. Consider Accepting of the 67th Avenue NE Overlay (88th St. NE to 108th St. NE) Project, Starting the 45-Day Lien Filing Period for Project Closeout
13. Consider Approval of the Professional Service Agreement with Waste Management Logistics in the Amount of \$56,500.00

DRAFT

14. Consider Approval of the Local Agency State Aid Project Prospectus and Local Agency State Funding Agreement with WSDOT thereby Securing Funding for the Grove Street Pedestrian and Bicycle Improvements (State Ave to Cedar Ave) Project
15. Consider Approval of the Local Agency State Aid Project Prospectus and Local Agency State Funding Agreement with WSDOT for Marshall Elementary Safe Routes to School Project
16. Consider Approval of the Supplement Number 2 to the Professional Services Agreement with HDR Engineering, Inc. for a No Cost Time Extension
17. Consider Approval of the Final Plat Approval of Emberly Subdivision along with the Associated Right-of-Way
22. Consider Approval of the September 2, 2015 claims in the amount of \$1,094,243.47; Paid by Check Number 102423 through 102588 with No Checks Voided
23. Consider Approval of the September 4, 2015 payroll in the amount \$1,608,382.82; Paid by Check Numbers 29230 through 29272 with Check Number 28572 Voided and Reissued with Check Number 29229

Motion made by Councilmember Wright, seconded by Councilmember Vaughan, to approve Consent Agenda items 2, 3, 10-17, 22, and 23. **Motion** passed unanimously (7-0).

Review Bids

Public Hearings

4. Consider Approval of the Program Year 2014 Consolidated Annual Performance and Evaluation Report and Direct Staff to Provide a Summary of, and Response to any Comments Received during the Public Hearing into the Report, and forward to the U.S. Department of Housing and Urban Development

Assistant Planner Amy Hess explained that HUD requires the City to complete a Consolidated Annual Performance and Evaluation Report (CAPER) in each program year to review the performance of the past year. All of the public service agencies that received funds either met or exceeded their goals for 2014. The Comeford Park improvement was completed with some of the additional funds, and the SR 528 pedestrian improvement project received funding for 2014 and 2015. It recently got approval from WSDOT so can move forward. Public Works is anticipating going out to bid by the end of this year and concluding by the end of 2016. The City is considered to be timely and in good standing with HUD. She commented that after this item was submitted for the agenda staff received additional guidance from the HUD rep about a reporting change staff needs to make. No other comments have been received from the

public. The only addition from last week is that one of the required reports had to be manually adjusted because some of the funds were drawn after June 30 date.

Mayor Nehring opened the public hearing at 7:09 p.m. Seeing no public comments, the hearing was closed at 7:09 p.m. He then solicited comments from the Council. There were none.

Motion made by Councilmember Muller, seconded by Councilmember Toyer, to approve the Program Year 2014 Consolidated Annual Performance and Evaluation Report and Direct Staff to Provide a Summary of, and Response to any Comments Received during the Public Hearing into the Report, and forward to the U.S. Department of Housing and Urban Development. **Motion** passed unanimously (7-0).

New Business

18. Consider Approval of an **Ordinance** Amending Section 2.24.030(5) of the Marysville Municipal Code, Establishing Salary for Municipal Court Judge, Provide for Severability; and Effective Date

Finance Director Langdon stated she had no additional information.

Motion made by Councilmember Vaughan, seconded by Councilmember Stevens, to adopt Ordinance No. 2999. **Motion** passed unanimously (7-0).

19. Consider Approval of an **Ordinance** Setting Forth the Basis of the City's Compliance with the Growth Management Act's (GMA) Required Review and Updating of the City's Comprehensive Plan and Development Regulations Under RCW 36.70A.130(5)(A), Repealing the Comprehensive Plan Adopted by Ordinance 2569, and Adopting a New Comprehensive Plan Pursuant to the City's Periodic GMA Comprehensive Plan Amendment and Update Process

Associate Planner Angela Gemmer reviewed the Comprehensive Plan update process and recommended that staff approve the Ordinance.

Motion made by Councilmember Muller, seconded by Councilmember Norton, to adopt Ordinance No. 3000. **Motion** passed unanimously (7-0).

20. Consider Approval of an **Ordinance** Amending Section 6.82.173 of the Marysville Municipal Code, Prohibiting the Use of Electronic Cigarettes in Parks; Providing for Severability; and Effective Date

Parks Director Jim Ballew stated there were no changes from last week's discussion. He summarized this would amend the code to include the prohibition of electronic cigarettes and vaping in city parks.

Motion made by Councilmember Wright, seconded by Councilmember Seibert, to adopt Ordinance No. 3001. **Motion** passed unanimously (7-0).

21. Consider Approval of a Resolution Declaring Various Equipment Certain Items of Personal Property to Be Surplus and Authorizing the Sale or Disposal Thereof

Director Nielsen stated he had no additional information. This is the standard surplusing method.

Motion made by Councilmember Muller, seconded by Councilmember Seibert, to adopt Resolution No. 2380. **Motion** passed unanimously (7-0).

24. An Ordinance of the City of Marysville Amending the 2015/2016 Biennial-Budget and Providing for the Increase of Certain Expenditure Items as Budgeted for in Ordinance No. 2972, and Changes in Compensation Levels

Finance Director Langdon stated this budget amendment add the teamsters salary schedule based on the contract that was provided to the Council last week.

Motion made by Councilmember Muller, seconded by Councilmember Norton, to adopt Ordinance No. 3002. **Motion** passed unanimously (7-0).

Legal

Mayor's Business

- Mayor Nehring thanked the Fire Department for putting on the 9/11 ceremony on Friday.
- He thanked the local congregations of the LDS church for their work at Mother Nature's Window last weekend.
- Touch-a-Truck was a great event and a beautiful day.
- The City will have a table at the Snohomish County Hall of Fame Banquet on Wednesday where Marysville will be recognized. Councilmembers should let Mayor Nehring know if they can attend.
- Snohomish County Cities meeting on Thursday night will be at the Harbor Point Golf Club in Mukilteo. They will be meeting with the County to go over areas where they can work together.

Staff Business

Chief Smith:

- He welcomed Collin Oliver to the meeting.
- He stated it was nice to see Community Development Director Dave Koenig and Chief McFalls at the table also.
- He gave a briefing on crime stats. He reviewed that the Police Department has had a goal of reducing crime by 20% since 2013, and overall they have done very well. They were able to reduce assaults by 14% since 2013 which is a reduction of 50 assaults citywide. Burglaries have been reduced by 118 which is

DRAFT

34%. Vehicle thefts have been reduced by 49 which is 22%. Vehicle prowls have been reduced by 105 or 44%. The SODA area is about the same as last year, but up slightly. He is reassessing their approach in this area. Some of the numbers are up because there was a tagger this year who tagged 35-40 places within the City including areas in the SODA. He commended his department for apprehending that tagger. Overall crime is down 5%; without theft it is down 15%.

- He gave an update on Operation Southern Comfort to address crime in the waterfront area.

Sandy Langdon stated that there is nothing on the agenda for the upcoming Finance Committee. There was consensus to cancel the meeting.

Deputy City Attorney Colin Olivers introduced himself.

Director Nielsen expressed appreciation for the working relationship among the different departments and spoke highly of the training they had today.

Director Ballew:

- He commended Amy Hess and Angela Gemmer for their work on the Comprehensive Plan and the CDBG Plan.
- Touch-a-Truck was a great event. The Army vehicles were incredible. This was one of the better attended events this year.
- Mother Nature's Window is really taking shape. They will be going out next month to look for a consultant for that area.
- He distributed a branding package for the Opera House with the fee structure for Council's information.
- The SR9 gateway monument sign is going to be installed on October 21 and 22.
- Councilmember Muller asked about the parking at the Opera House. Director Ballew explained that plan is to upgrade striping on Cedar. Funds are available to increase the off-street parking on the location as well. He added that he attended several events there over the summer and did not see a challenge even when the facility is close to capacity.

Chief McFalls:

- He thanked Mayor Nehring for his words of encouragement and support at the 9/11 event. He also thanked the Police Department for joining them in the event.
- The Fire Department enjoyed the managers and supervisors training.
- He enjoyed the Touch-a-Truck event.

Dave Koenig:

- He also recognized Amy Hess and Angela Gemmer for their efforts.
- There has been a lot of interest in development at 172nd Street. Apartments and commercial development is being phased as the improvements are completed.

Gloria Hirashima:

- She thanked Amy Hess and Angela Gemmer for their work on the projects. She also recognized staff members from different departments for their work on their respective elements.
- She gave an update on a grant program the City is initiating. The City is interested in partnering with the community and neighborhoods to encourage community clean up and improvement efforts.
- The Lakewood Master Plan will be brought back in the fall to allow more time to respond to questions and concerns.

Call on Councilmembers

Kamille Norton:

- Mother Nature's Window is a beautiful property. She is excited to see what the plan is for the park.
- She thanked Mike Robinson for his great work at making the projects successful.

Steve Muller:

- 9/11 Ceremony was wonderful.
- Touch-a-Truck was an awesome event and well attended.
- The high tides are corresponding with sunsets lately which results in a beautiful scene.
- He commended staff for all their work, especially Amy Hess and Angela Gemmer.

Rob Toyer commended Chief Smith and Chief McFalls for their participation in the 9/11 event as well as Mayor Nehring for his comments.

Michael Stevens:

- He thoroughly enjoyed the Touch-a-Truck, especially the music.
- It's good to be back.
- Great work to Angela Gemmer, Amy Hess, and the whole department for the updates.
- He welcomed Colin Olivers, Dave Koenig, and Chief McFalls to the meeting.

Jeff Seibert:

- He commended Angela Gemmer, Amy Hess, and all the other staff that participated in the documents.

Donna Wright:

- She echoed congratulations to staff for work on the Comprehensive Plan Update.
- Touch-a-Truck was tremendously successful.
- The Fire Service Awards will be given out next Wednesday.
- She asked how the Farmers Market is doing. Director Ballew said he hears it is going well. It will conclude at the end of September. He believes they hope to come back.

DRAFT

Jeff Vaughan:

- He echoed comments about the 9/11 Ceremony. It was very well done by Fire and Police. He also appreciated the Mayor's comments and the invocation by Pastor Kanehan. He appreciates the efforts of staff to get information out on social media.
- He commended Mike Robinson for his work with the volunteers.

Adjournment

Seeing no further business Mayor Nehring adjourned the meeting at 7:50 p.m.

Approved this _____ day of _____, 2015.

Mayor
Jon Nehring

April O'Brien
Deputy City Clerk

Update
Index #14

Call to Order/Pledge of Allegiance/Roll Call	7:00 p.m.
Approval of absence of Councilmember Toyer	Approved
Approval of the Agenda	Approved
Committee Reports	
Presentations	
Employee Services Awards: <ul style="list-style-type: none"> Kevin Ward, Maintenance Worker I, Public Works – 10 years Jonathon Elton, Police Elton, Police Officer – 10 years Michael Stevens, Councilmember – 5 years Mayor Nehring – 5 years as Mayor 	Presented
Audience Participation	
Approval of Minutes	
Approval of the September 8, 2015 City Council Work Session Minutes	Approved
Consent Agenda	
Approval of the September 9, 2015 Claims in the Amount of \$186,023.12; Paid by Check Number 102589 through 102697 with Check Numbers 102028, 102216, and 102581 Voided	Approved
Approval of the September 16, 2015 Claims in the Amount of \$786,008.33; Paid by Check Number 102698 through 102797 with Check Number 102668 Voided	Approved
Review Bids	
Consider awarding the bid for the 2015 Biosolids Removal and Reuse Project in the Amount Totaling \$4,588,918.83 to American Process Group, Inc.	Approved
Public Hearings	
New Business	
Consider the Snohomish County Homeland Security Grant Agreement in the Amount of \$35,000.00	Approved
Consider the 2015-2016 Hotel/Motel Grant Recommendations to Award Funding	Approved
Consider the Communication Site Sublease with I-COM	Approved
Consider the Professional Services Agreement with Government Portfolio Advisors, LLC for Consultant Services	Approved
Consider the Interlocal Agreement with Snohomish County for Emergency Management Services	Approved
Consider a Resolution Declaring Certain Technology Hardware Items of Personal Property to be Surplus and Authorizing the Sale of Disposal Thereof	Approved Res. No. 2381
Consider a Professional Services Agreement – Mayer/Reed	Approved
Mayor's Business	
Consider the Appointment of Allina Holmquist as City Clerk	Approved
Staff Business	
Call on Councilmembers	
Adjournment	8:06 p.m.

Executive Session	8:13 p.m.
Real Estate – one item	
Reconvenement	8:20 p.m.
Action	Approved
Adjournment	8:20 p.m.

COUNCIL*DRAFT*
MINUTES

Regular Meeting
September 28, 2015

Call to Order / Pledge of Allegiance

Mayor Nehring called the meeting to order at 7:00 p.m. Pastor Jeff Hastings from the Reser Church gave the invocation, and Mayor Nehring led those present in the Pledge of Allegiance.

Roll Call

Chief Administrative Officer Hirashima gave the roll call. The following staff and councilmembers were in attendance.

Mayor: Jon Nehring

Council: Steve Muller, Kamille Norton, Jeff Seibert, Michael Stevens, Jeff Vaughan, and Donna Wright

Absent: Rob Toyer

Also Present: Chief Administrative Officer Gloria Hirashima, Finance Director Sandy Langdon, Police Commander Lamoureux, City Attorney Jon Walker, Public Works Director Kevin Nielsen, Parks and Recreation Director Jim Ballew, Community Development Director Dave Koenig, Fire Chief Martin McFalls, and Recording Secretary Laurie Hugdahl.

Motion made by Councilmember Stevens, seconded by Councilmember Muller, to excuse Councilmember Toyer who was home ill. **Motion** passed unanimously (6-0).

Approval of Agenda

CAO Hirashima explained that staff is proposing the addition of a professional services agreement with Mayer/Reed on tonight's agenda. This is an architectural firm with considerable experience in park and trail planning. This agreement would include the waterfront park concept and master plan of the trail concept.

Motion made by Councilmember Muller, seconded by Councilmember Stevens, to approve the agenda with the addition of the PSA with Mayer/Reed as item 12. **Motion** passed unanimously (6-0).

Committee Reports

Councilmember Vaughan reported that the **LEOFF I Board** met last Wednesday and reviewed and approved two claims.

Presentations

A. Employee Services Awards

The following employees were recognized for their service at the meeting:

- Kevin Ward, Maintenance Worker I, Public Works – 10 years
- Jonathon Elton, Police Elton, Police Officer – 10 years
- Michael Stevens, Councilmember – 5 years
- Mayor Nehring – 5 years as Mayor

B. Volunteer of the Month

None

Audience Participation**Approval of Minutes**

1. Approval of the September 8, 2015 City Council Work Session Minutes

Councilmember Stevens stated he would be abstaining from the vote since he was absent at the September 8, 2015 meeting.

Motion made by Councilmember Wright, seconded by Councilmember Vaughan, to approve the September 8, 2015 City Council Work Session Minutes. **Motion** passed (5-0) with Councilmember Stevens abstaining.

Consent

2. Approval of the September 9, 2015 Claims in the Amount of \$186,023.12; Paid by Check Number 102589 through 102697 with Check Numbers 102028, 102216, and 102581 Voided
3. Approval of the September 16, 2015 Claims in the Amount of \$786,008.33; Paid by Check Number 102698 through 102797 with Check Number 102668 Voided

Motion made by Councilmember Muller, seconded by Councilmember Norton, to approve Consent Agenda items 2 and 3. **Motion** passed unanimously (6-0).

Review Bids

4. Consider awarding the bid for the 2015 Biosolids Removal and Reuse Project in the Amount Totaling \$4,588,918.83 to American Process Group, Inc.

Director Nielsen reviewed this item.

Motion made by Councilmember Muller, seconded by Councilmember Vaughan, to approve the bid for the 2015 Biosolids Removal and Reuse Project in the Amount Totaling \$4,588,918.83 to American Process Group, Inc. **Motion** passed unanimously (6-0).

Public Hearings**New Business**

6. Consider the Snohomish County Homeland Security Grant Agreement in the Amount of \$35,000.00

CAO Hirashima explained this is a pass through for a Snohomish County Homeland Security Grant working with DEM. This will provide some funding for some of the City's Emergency Management Program expenses.

Motion made by Councilmember Stevens, seconded by Councilmember Muller, to authorize the Mayor to sign the Snohomish County Homeland Security Grant Agreement in the Amount of \$35,000.00. **Motion** passed unanimously (6-0).

7. Consider the 2015-2016 Hotel/Motel Grant Recommendations to Award Funding

CAO Hirashima explained this is the recommendation of the Hotel/Motel Committee who reviewed a large number of grant applications.

Councilmember Muller abstained from voting since he is on the Board with the Marysville Historical Society which is one of the applicants.

Motion made by Councilmember Stevens, seconded by Councilmember Vaughan, to approve the 2015-2016 Hotel/Motel Grant Recommendations to Award Funding. **Motion** passed (5-0) with Councilmember Muller abstaining.

8. Consider the Communication Site Sublease with I-COM

Director Nielsen explained this is a supplemental agreement with I-COM with the Sears tower.

Motion made by Councilmember Wright, seconded by Councilmember Seibert, to approve the Communication Site Sublease with I-COM. **Motion** passed unanimously (6-0).

9. Consider the Professional Services Agreement with Government Portfolio Advisors, LLC for Consultant Services

Finance Director Langdon explained this was submitted as a request to move to an investment advisor. Staff thinks this is a better plan for the City's investment. This contract piggybacks off the City of Kirkland's process.

Motion made by Councilmember Seibert, seconded by Councilmember Stevens, to approve the Professional Services Agreement with Government Portfolio Advisors, LLC for Consultant Services. **Motion** passed unanimously (6-0).

10. Consider the Interlocal Agreement with Snohomish County for Emergency Management Services

CAO Hirashima reviewed this item.

Motion made by Councilmember Muller, seconded by Councilmember Stevens, to approve the Interlocal Agreement with Snohomish County for Emergency Management Services. **Motion** passed unanimously (6-0).

11. Consider a Resolution Declaring Certain Technology Hardware Items of Personal Property to be Surplus and Authorizing the Sale of Disposal Thereof

IT Manager Worth Norton explained these items came out of the Public Safety building when they did an upgrade.

Motion made by Councilmember Vaughan, seconded by Councilmember Wright, to approve Resolution No. 2381. **Motion** passed unanimously (6-0).

12. Professional Services Agreement – Mayer/Reed

CAO Hirashima explained there is approximately \$350,000 in this year's biennial budget for this. There also is a grant for approximately \$340,000 and a \$500,000 capital appropriation from the state.

Councilmember Muller asked how far out this would go. CAO Hirashima stated the master plan concept would identify the trail network system, but would not include actual construction.

Motion made by Councilmember Muller, seconded by Councilmember Wright, to approve the Professional Services Agreement with Mayer/Reed. **Motion** passed unanimously (6-0).

Legal

Mayor's Business

12. Consider the Appointment of Allina Holmquist as City Clerk

Motion made by Councilmember Norton, seconded by Councilmember Stevens, to approve the appointment of Allina Holmquist as City Clerk. **Motion** passed unanimously (6-0).

Other Mayor's Business:

- There was a groundbreaking for the Washington State University site in North Everett. This is a great opportunity for the region with expanded programs starting for those entering programs in the fall of 2017.
- Marysville Food Bank is having a fundraiser this Wednesday night from 4 to 6:30.
- Thanks to Councilmember Vaughan for the presentation earlier.

Legal

Staff Business

Dave Koenig:

- He received an email that talked about great cities for millennials from www.getrichslowly.org. Marysville was ranked #7 in the country as a place for millennials to live.
- A senior construction inspector resigned so staff will be going through the replacement process.

Chief McFalls:

- The Fire Department had its award banquet and 17 members were recognized for their service.

Worth Norton had no comments.

Jim Ballew:

- Farmers Market concluded this weekend.
- The Marysville Craft Fair has become so large that it will be moving to Totem on October 10.

Kevin Nielsen:

- WSDOT informed him the City received \$205,000 in grant money for Safe Sidewalks to School on Sunnyside.
- He asked the Public Works Committee to postpone October's meeting. He and Sandy are working on a utility rate model to bring to the committee in November.
- Sunnyside has striping complete.
- Traffic circles on 71st are complete.

Jon Walker stated the need for an Executive Session to discuss one item regarding the acquisition of real estate for seven minutes with action expected.

Sandy Langdon had no comments.

Robb Lamoureux reported that the Police Department was awarded a \$375,000 Cops grant this year. The vision is to greatly enhance the School Resource Officer program. Mayor Nehring commended Commander Lamoureux for his work on writing that grant.

Gloria Hirashima:

- She reported that the cert program was very popular and there ended up being a waitlist.
- She is attending the International City Managers Conference in Seattle. It's been interesting meeting people from cities across the country.

Call on Councilmembers

Kamille Norton congratulated Michael Stevens and Mayor Nehring for their awards.

Steve Muller:

- He also congratulated Michael Stevens and Mayor Nehring for their awards.
- He went to the sports banquet which was a good event.

Michael Stevens expressed appreciation for the opportunity to serve the community for the past five years.

Jeff Seibert had no comments.

Donna Wright:

- She stated it's a privilege to serve with Councilmember Stevens and Mayor Nehring.
- The Soroptomist Auction will be held on October 23, and she has tickets available.

Jeff Vaughan suggested that part of the reason for the success of the cert training might have to do with the timing after the recent wind storm and power outage. The social media outreach on that also helped spread the word.

Adjournment

Mayor Nehring recessed the meeting from 8:06 recess until 8:13 at which time the Council reconvened in Executive Session for seven minutes to discuss one real estate item with action expected.

*DRAFT***Executive Session**

- A. Litigation**
- B. Personnel**
- C. Real Estate** – one item, Per RCW 42.30.110(1)(b) with action expected.

Executive session ended and public meeting reconvened at 8:20 p.m.

Motion made by Councilmember Seibert, seconded by Councilmember Stevens, to authorize the Mayor to sign the real estate purchase and sale agreement for the Welco property. **Motion** passed unanimously (6-0).

Adjournment

Seeing no further business Mayor Nehring adjourned the meeting at 8:20 p.m.

Approved this _____ day of _____, 2015.

Mayor
Jon Nehring

April O'Brien
Deputy City Clerk

Index #2

CITY OF MARYSVILLE

EXECUTIVE SUMMARY FOR ACTION

CITY COUNCIL MEETING DATE: October 12, 2015

AGENDA ITEM: Claims	AGENDA SECTION:	
PREPARED BY: Sandy Langdon, Finance Director	AGENDA NUMBER:	
ATTACHMENTS: Claims Listings	APPROVED BY:	
	MAYOR	CAO
BUDGET CODE:	AMOUNT:	

Please see attached.

<p>RECOMMENDED ACTION:</p> <p>The Finance and Executive Departments recommend City Council approve the September 23, 2015 claims in the amount of \$903,453.65 paid by Check No. 102798 through 102937 with no Check No. voided.</p> <p>COUNCIL ACTION:</p>
--

BLANKET CERTIFICATION
CLAIMS
FOR
PERIOD-9

I, THE UNDERSIGNED, DO HEREBY CERTIFY UNDER PENALTY OF PERJURY THAT THE MATERIALS HAVE BEEN FURNISHED, THE SERVICES RENDERED OR THE LABOR PERFORMED AS DESCRIBED HEREIN AND THAT THE CLAIMS IN THE AMOUNT OF \$903,453.65 PAID BY CHECK NO.'S 102798 THROUGH 102937 WITH NO CHECK NO. VOIDED ARE JUST, DUE AND UNPAID OBLIGATIONS AGAINST THE CITY OF MARYSVILLE, AND THAT I AM AUTHORIZED TO AUTHENTICATE AND TO CERTIFY SAID CLAIMS.

AUDITING OFFICER DATE

MAYOR DATE

WE, THE UNDERSIGNED COUNCIL MEMBERS OF MARYSVILLE, WASHINGTON DO HEREBY APPROVE FOR PAYMENT THE ABOVE MENTIONED CLAIMS ON THIS 12th DAY OF OCTOBER 2015.

COUNCIL MEMBER

COUNCIL MEMBER

COUNCIL MEMBER

COUNCIL MEMBER

COUNCIL MEMBER

COUNCIL MEMBER

COUNCIL MEMBER

DATE: 9/23/2015
TIME: 10:22:31AM

**CITY OF MARYSVILLE
INVOICE LIST**

PAGE: 1

FOR INVOICES FROM 9/17/2015 TO 9/23/2015

<u>CHK #</u>	<u>VENDOR</u>	<u>ITEM DESCRIPTION</u>	<u>ACCOUNT DESCRIPTION</u>	<u>ITEM AMOUNT</u>
102798	REVENUE, DEPT OF	SALES & USE TAXES-AUG 2015	CITY CLERK	0.03
	REVENUE, DEPT OF		COMMUNITY DEVELOPMENT-	8.86
	REVENUE, DEPT OF		WATER/SEWER OPERATION	25.17
	REVENUE, DEPT OF		POLICE ADMINISTRATION	31.46
	REVENUE, DEPT OF		CITY STREETS	271.52
	REVENUE, DEPT OF		RECREATION SERVICES	402.90
	REVENUE, DEPT OF		PRO-SHOP	699.32
	REVENUE, DEPT OF		GENERAL FUND	1,317.52
	REVENUE, DEPT OF		STORM DRAINAGE	6,262.79
	REVENUE, DEPT OF		GOLF COURSE	13,752.88
	REVENUE, DEPT OF		SOLID WASTE OPERATIONS	29,111.65
	REVENUE, DEPT OF		UTIL ADMIN	80,473.20
102799	ADAMS, ANGEL	JURY DUTY	COURTS	12.28
102800	ADVANCED TRAFFIC	GREEN ARROWS AND SIGNAL LEDS	TRANSPORTATION MANAGEM	582.95
102801	AG SPRAY EQUIPMENT	COUPLERS	SMALL ENGINE SHOP	70.14
	AG SPRAY EQUIPMENT	WATER TANK PUMP	SMALL ENGINE SHOP	335.50
102802	AHERN, JANIS	JURY DUTY	COURTS	14.56
102803	ALBERTSONS	MEETING SUPPLIES	UTIL ADMIN	69.16
102804	ALBERTSONS	REC EXPRESS/MTG/EVENT SUPPLIES	PARK & RECREATION FAC	17.63
	ALBERTSONS		COMMUNITY EVENTS	42.86
	ALBERTSONS		RECREATION SERVICES	100.37
102805	ARAMARK UNIFORM	UNIFORM SERVICE	SMALL ENGINE SHOP	4.15
	ARAMARK UNIFORM		SMALL ENGINE SHOP	4.15
	ARAMARK UNIFORM		EQUIPMENT RENTAL	38.16
	ARAMARK UNIFORM		EQUIPMENT RENTAL	76.66
102806	BANK OF AMERICA	PARKING REIMBURSEMENT	POLICE ADMINISTRATION	3.00
102807	BANK OF AMERICA	WEB SERVICE REIMBURSEMENT	COMPUTER SERVICES	5.81
102808	BANK OF AMERICA	SUPPLY REIMBURSEMENT	POLICE INVESTIGATION	540.68
102809	BANK OF AMERICA		POLICE PATROL	108.79
	BANK OF AMERICA		OFFICE OPERATIONS	554.86
102810	BANK OF AMERICA	SUPPLY/FEE REIMBURSEMENT	RECREATION SERVICES	25.00
	BANK OF AMERICA		PARK & RECREATION FAC	33.18
	BANK OF AMERICA		RECREATION SERVICES	89.06
	BANK OF AMERICA		RECREATION SERVICES	133.25
	BANK OF AMERICA		SOLID WASTE CUSTOMER EX	183.71
	BANK OF AMERICA		PARK & RECREATION FAC	209.97
102811	BANK OF AMERICA	EMPLOYEE APPRECIATION/SUPPLY R	WATER/SEWER OPERATION	-54.74
	BANK OF AMERICA		UTIL ADMIN	193.22
	BANK OF AMERICA		WASTE WATER TREATMENT F	203.02
	BANK OF AMERICA		SEWER MAIN COLLECTION	203.02
	BANK OF AMERICA		WATER DIST MAINS	270.70
102812	BANK OF AMERICA	TRAVEL/TRAINING REIMBURSEMENT	POLICE ADMINISTRATION	5.70
	BANK OF AMERICA		POLICE INVESTIGATION	246.52
	BANK OF AMERICA		POLICE PATROL	299.20
	BANK OF AMERICA		POLICE TRAINING-FIREARMS	700.00
102813	BANK OF AMERICA		CITY COUNCIL	358.20
	BANK OF AMERICA		EXECUTIVE ADMIN	549.20
	BANK OF AMERICA		CITY COUNCIL	750.00
102814	BENSON, DAVE	RENTAL DEPOSIT REFUND	GENERAL FUND	100.00
102815	BICKFORD FORD	CONNECTOR	EQUIPMENT RENTAL	4.50
	BICKFORD FORD	COIL AND PLUG	EQUIPMENT RENTAL	57.83
	BICKFORD FORD	TPMS SENSOR	EQUIPMENT RENTAL	64.64
102816	BIGELOW, MICHAEL	JURY DUTY	COURTS	10.28
102817	BNSF RAILWAY COMPANY	INSTALL WIDE CROSSING	GMA - STREET	7,045.51
	BNSF RAILWAY COMPANY	INSTALL FLASHERS	GMA - STREET	7,415.50
102818	BRADY, GAIL	REFUND CLASS FEES	PARKS-RECREATION	72.00
102819	BRIM TRACTOR	FILTERS	ER&R	83.94
102820	BROCK, TINA	REIMBURSE AWARD SUPPLY EXPENSE	PERSONNEL ADMINISTRATIOI	21.66
102821	CARLSEN, DEBRA	JURY DUTY	COURTS	11.14
102822	CEDAR GROVE COMPOST	AWARDING ATTORNEY FEES AND COS	NON-DEPARTMENTAL	12,361.10
	CEDAR GROVE COMPOST		WASTE WATER TREATMENT F	37,083.29

DATE: 9/23/2015
TIME: 10:22:31AM

CITY OF MARYSVILLE
INVOICE LIST
FOR INVOICES FROM 9/17/2015 TO 9/23/2015

PAGE: 2

<u>CHK #</u>	<u>VENDOR</u>	<u>ITEM DESCRIPTION</u>	<u>ACCOUNT DESCRIPTION</u>	<u>ITEM AMOUNT</u>
102823	CENTRAL WELDING SUPP	WYPALL WIPES	ER&R	172.34
	CENTRAL WELDING SUPP	BROOMS AND SHOVELS	ER&R	293.76
102824	CHEMTRADE CHEMICALS	ALUMINUM SULFATE	WASTE WATER TREATMENT F	4,063.38
102825	CLICK2MAIL	MAILING COSTS	COMMUNITY DEVELOPMENT-	933.91
102826	COGDILL, KAREN	JURY DUTY	COURTS	18.20
102827	COMMERCE DEPT OF	STILLY WATER SYSTEM IMPROVEMEN	ENTERPRISE D/S	30,023.70
	COMMERCE DEPT OF		ENTERPRISE D/S	222,397.81
102828	COMMERCIAL FIRE	FIRE EXTINGUISHER SERVICE	ER&R	85.95
102829	COOP SUPPLY	OVERSEED	WATER SERVICES	18.49
	COOP SUPPLY	PEST CONTROL SUPPLIES	WATER RESERVOIRS	41.33
102830	CORRECTIONS, DEPT OF	WORK CREW-JULY 2015	WATER RESERVOIRS	93.84
	CORRECTIONS, DEPT OF		ROADSIDE VEGETATION	146.04
	CORRECTIONS, DEPT OF		PARK & RECREATION FAC	174.88
102831	COUGAR TREE SERVICE	TREE REMOVAL	ROADSIDE VEGETATION	380.80
	COUGAR TREE SERVICE		ROADSIDE VEGETATION	2,448.00
102832	CUNNINGHAM, TONI	RENTAL DEPOSIT REFUND	GENERAL FUND	100.00
102833	DARLING, FRANCES		GENERAL FUND	200.00
102834	DAY, SAM	REIMBURSE CDL RENEWAL EXPENSES	SOLID WASTE OPERATIONS	102.00
102835	DIAMOND B CONSTRUCT	HVAC MAINTENANCE	SOURCE OF SUPPLY	96.65
	DIAMOND B CONSTRUCT		PARK & RECREATION FAC	202.41
	DIAMOND B CONSTRUCT		NON-DEPARTMENTAL	226.97
	DIAMOND B CONSTRUCT		MAINT OF GENL PLANT	246.19
	DIAMOND B CONSTRUCT		COMMUNITY CENTER	299.06
	DIAMOND B CONSTRUCT	REPAIR AT COURT	COURT FACILITIES	402.02
	DIAMOND B CONSTRUCT	HVAC MAINTENANCE	WATER FILTRATION PLANT	611.62
	DIAMOND B CONSTRUCT		MAINTENANCE	669.20
	DIAMOND B CONSTRUCT	REPAIR WALK IN FREEZER	PUBLIC SAFETY BLDG.	685.98
	DIAMOND B CONSTRUCT	RELOCATE TSTAT AND AIR FLOW	ADMIN FACILITIES	717.81
	DIAMOND B CONSTRUCT	HVAC MAINTENANCE	COURT FACILITIES	800.53
	DIAMOND B CONSTRUCT		UTIL ADMIN	814.20
	DIAMOND B CONSTRUCT		ADMIN FACILITIES	864.24
	DIAMOND B CONSTRUCT		WASTE WATER TREATMENT F	1,023.60
	DIAMOND B CONSTRUCT		LIBRARY-GENL	1,116.55
	DIAMOND B CONSTRUCT		PUBLIC SAFETY BLDG.	1,413.76
102836	DIASIO, SUZANNE	RENTAL DEPOSIT REFUND	GENERAL FUND	100.00
102837	DMCMA	DMCMA FALL REGIONAL (3)	PROBATION	75.00
102838	DORAN, BECKY	UB 331475501300 14905 44TH AVE	WATER/SEWER OPERATION	69.18
102839	E&E LUMBER	LUMBER	STORM DRAINAGE	367.66
102840	EAST JORDAN IRON WOR	WATER VALVE COVERS	WATER/SEWER OPERATION	91.78
102841	EDGE ANALYTICAL	LAB ANALYSIS	WATER QUAL TREATMENT	10.50
	EDGE ANALYTICAL		WATER QUAL TREATMENT	12.00
	EDGE ANALYTICAL		WATER QUAL TREATMENT	12.00
	EDGE ANALYTICAL		WATER QUAL TREATMENT	12.00
	EDGE ANALYTICAL		WATER QUAL TREATMENT	12.00
	EDGE ANALYTICAL		WATER QUAL TREATMENT	12.00
	EDGE ANALYTICAL		WATER QUAL TREATMENT	12.00
	EDGE ANALYTICAL		WATER QUAL TREATMENT	12.00
	EDGE ANALYTICAL		WATER QUAL TREATMENT	12.00
	EDGE ANALYTICAL		WATER QUAL TREATMENT	24.00
	EDGE ANALYTICAL		WATER QUAL TREATMENT	24.00
	EDGE ANALYTICAL		WATER QUAL TREATMENT	58.00
	EDGE ANALYTICAL		WATER QUAL TREATMENT	189.00
	EDGE ANALYTICAL		WATER QUAL TREATMENT	189.00
	EDGE ANALYTICAL		WATER QUAL TREATMENT	1,032.00
102842	ENVIRONMENTAL CONTRO	JANITORIAL SERVICES	WATER FILTRATION PLANT	39.66
	ENVIRONMENTAL CONTRO		PARK & RECREATION FAC	350.26
	ENVIRONMENTAL CONTRO		COMMUNITY CENTER	396.52
	ENVIRONMENTAL CONTRO		WASTE WATER TREATMENT F	475.82
	ENVIRONMENTAL CONTRO		UTIL ADMIN	793.04
	ENVIRONMENTAL CONTRO		MAINT OF GENL PLANT	1,116.13
	ENVIRONMENTAL CONTRO		COURT FACILITIES	1,189.56
	ENVIRONMENTAL CONTRO		PUBLIC SAFETY BLDG.	1,253.00
	ENVIRONMENTAL CONTRO		ADMIN FACILITIES	1,384.96

DATE: 9/23/2015
TIME: 10:22:31AM

**CITY OF MARYSVILLE
INVOICE LIST**

PAGE: 3

FOR INVOICES FROM 9/17/2015 TO 9/23/2015

<u>CHK #</u>	<u>VENDOR</u>	<u>ITEM DESCRIPTION</u>	<u>ACCOUNT DESCRIPTION</u>	<u>ITEM AMOUNT</u>
102843	EVERETT OFFICE	BOOKCASE-KBCC	COMMUNITY CENTER	205.63
102844	EVERETT, CITY OF	LAB ANALYSIS	STORM DRAINAGE	189.00
102845	FEDEX	SHIPPING EXPENSE	PUMPING PLANT	8.71
102846	FIRESTONE	TIRES	EQUIPMENT RENTAL	285.97
102847	FLORIAN, LLC	INSTRUCTOR SERVICES	RECREATION SERVICES	180.00
102848	FOLLMAN AGENCY LLC	ASSESSMENT	DETENTION & CORRECTION	175.00
102849	FRONTIER COMMUNICATI	ACCT #36065150331108105	EXECUTIVE ADMIN	27.96
	FRONTIER COMMUNICATI	ACCT #36065894930725005	POLICE INVESTIGATION	28.92
	FRONTIER COMMUNICATI		RECREATION SERVICES	28.92
	FRONTIER COMMUNICATI	ACCT #36065774950927115	STREET LIGHTING	46.42
	FRONTIER COMMUNICATI	ACCT #36065836350725085	COMMUNITY DEVELOPMENT-	47.28
	FRONTIER COMMUNICATI		UTIL ADMIN	47.29
	FRONTIER COMMUNICATI	ACCT #36065347410509955	WASTE WATER TREATMENT F	50.67
	FRONTIER COMMUNICATI	ACCT #36065852920604075	PERSONNEL ADMINISTRATIO	67.31
	FRONTIER COMMUNICATI		MUNICIPAL COURTS	234.61
102850	GILLINGS, FRED	REIMBURSE MILEAGE	PROBATION	40.65
102851	GOVCONNECTION INC	PERIPHERAL REPLACEMENTS	COMPUTER SERVICES	105.63
	GOVCONNECTION INC		COMPUTER SERVICES	140.35
102852	GRAINGER	EXPANSION PLUGS	EQUIPMENT RENTAL	80.90
102853	GREENE, EARL & FUMIK	UB 890710000000 7722 56TH DR N	WATER/SEWER OPERATION	48.00
102854	GRIFFIN, STEVE & RHO	UB 270790000000 12131 52ND AVE	WATER/SEWER OPERATION	7.91
102855	GROUP HEALTH	DOT PHYSICALS	FACILITY MAINTENANCE	95.00
	GROUP HEALTH		GENERAL SERVICES - OVER	190.00
	GROUP HEALTH		UTIL ADMIN	285.00
102856	GUILD MORTGAGE COMPA	UB 934230000000 1729 8TH ST	WATER/SEWER OPERATION	22.01
102857	GUTIERREZ, ALBERTO	UB 986529000000 6529 32ND PL N	GARBAGE	3.06
	GUTIERREZ, ALBERTO		GARBAGE	9.84
	GUTIERREZ, ALBERTO		WATER/SEWER OPERATION	15.00
102858	HD FOWLER COMPANY	PIPE	STORM DRAINAGE	186.05
	HD FOWLER COMPANY	TAPE MEASURE AND MISC TAPE	ER&R	190.33
	HD FOWLER COMPANY	COPPER TUBING	WATER/SEWER OPERATION	302.25
	HD FOWLER COMPANY	VALVES, TEES AND CURB STOPS	WATER/SEWER OPERATION	538.12
102859	HENNIG, JEANINE TULL	INSTRUCTOR SERVICES	RECREATION SERVICES	154.80
	HENNIG, JEANINE TULL		RECREATION SERVICES	313.20
102860	HERTZ EQUIPMENT RENT	LIFT RENTAL	MAINT OF GENL PLANT	734.40
102861	JESS, TAMERA	JURY DUTY	COURTS	12.28
102862	JONES, KENNETH	UB 570705550001 2720 179TH PL	WATER/SEWER OPERATION	22.61
102863	KASNER, AMANDA	JURY DUTY	COURTS	13.99
102864	KILLHAM, EDWARD	UB 651445250002 10121 62ND DR	WATER/SEWER OPERATION	19.23
102865	KIMBROUGH, SARAH	JURY DUTY	COURTS	13.87
102866	KYLE, BRANDON	UB 762200000000 6704 63RD DR N	WATER/SEWER OPERATION	16.39
102867	LASTING IMPRESSIONS	HATS W/LOGO	ER&R	466.10
102868	LAYTON, JUDY	JURY DUTY	COURTS	20.26
102869	LEE, CHRISTINE		COURTS	13.13
102870	LEONARD, REMY	PRO-TEM SERVICES	MUNICIPAL COURTS	1,850.00
102871	LEONE, KRISTINE	UB 530640000001 3815 178TH PL	WATER/SEWER OPERATION	16.78
102872	LES SCHWAB TIRE CTR	TIRE REPAIR	EQUIPMENT RENTAL	27.20
102873	LICENSING, DEPT OF	BURLISON, NANCY (ORIGINAL)	GENERAL FUND	18.00
	LICENSING, DEPT OF	EVANS, NANCY (RENEWAL)	GENERAL FUND	18.00
	LICENSING, DEPT OF	KENYON, KURT (ORIGINAL)	GENERAL FUND	18.00
	LICENSING, DEPT OF	MONTOYA, DAVID (RENEWAL)	GENERAL FUND	18.00
	LICENSING, DEPT OF	MORALES MONTERO, CHRISTIAN (RE	GENERAL FUND	18.00
	LICENSING, DEPT OF	OVERTON, ANTONIO (ORIGINAL)	GENERAL FUND	18.00
102874	LOWES HIW INC	FILTERS	MAINT OF GENL PLANT	62.05
102875	MANOR HARDWARE	REPAIR NAIL GUN, EXT CORDS, HA	FACILITY MAINTENANCE	155.49
102876	MARYSVILLE, CITY OF	UTILITY SERVICE-TUSCAN RIDGE I	PARK & RECREATION FAC	110.10
	MARYSVILLE, CITY OF	UTILITY SERVICE-6802 84TH ST N	PRO-SHOP	192.48
	MARYSVILLE, CITY OF	UTILITY SERVICE-1635 GROVE ST	PUBLIC SAFETY BLDG.	2,267.31
102877	MCDONALD, KEVIN D	HEARING EXAMINER SERVICE	COMMUNITY DEVELOPMENT-	743.13
102878	MILLER, LUCINDA	JURY DUTY	COURTS	12.85
102879	MINCHUK, DMITRIY & N	UB 757246530000 7246 53RD ST N	WATER/SEWER OPERATION	8.08

DATE: 9/23/2015
TIME: 10:22:31AM

**CITY OF MARYSVILLE
INVOICE LIST**

PAGE: 4

FOR INVOICES FROM 9/17/2015 TO 9/23/2015

<u>CHK #</u>	<u>VENDOR</u>	<u>ITEM DESCRIPTION</u>	<u>ACCOUNT DESCRIPTION</u>	<u>ITEM AMOUNT</u>
102880	MIZELL, TARA	REIMBURSE SUPPLY EXPENSES	RECREATION SERVICES	36.89
102881	MODULAR SPACE	TRAILER RENTAL	WASTE WATER TREATMENT F	97.72
	MODULAR SPACE		WATER QUAL TREATMENT	97.72
	MODULAR SPACE		STORM DRAINAGE	97.73
102882	NATIONAL BARRICADE	ANTI-PAN HANDLING SIGNS	TRANSPORTATION MANAGEM	401.82
102883	NICLAI, CHERYL	REIMBURSE LUNCH EXPENSE	UTIL ADMIN	24.37
102884	NORPAC ENTERPRISES	BANDS, BUCKLES AND TOOL	TRANSPORTATION MANAGEM	496.13
102885	NORTHSTAR CHEMICAL	SODIUM HYPOCHLORITE	WATER FILTRATION PLANT	523.10
	NORTHSTAR CHEMICAL		WATER QUAL TREATMENT	523.10
	NORTHSTAR CHEMICAL		WATER FILTRATION PLANT	663.50
	NORTHSTAR CHEMICAL		WATER QUAL TREATMENT	663.50
102886	OFFICE DEPOT	RETURN OFFICE SUPPLIES	GENERAL SERVICES - OVERH	-76.11
	OFFICE DEPOT	OFFICE SUPPLIES	UTIL ADMIN	11.99
	OFFICE DEPOT		ENGR-GENL	11.99
	OFFICE DEPOT		ENGR-GENL	20.39
	OFFICE DEPOT		STORM DRAINAGE	27.20
	OFFICE DEPOT		UTIL ADMIN	28.29
	OFFICE DEPOT		WASTE WATER TREATMENT F	34.18
	OFFICE DEPOT		UTIL ADMIN	34.81
	OFFICE DEPOT		ENGR-GENL	70.16
	OFFICE DEPOT		COMMUNITY DEVELOPMENT-	77.64
	OFFICE DEPOT		UTIL ADMIN	77.64
	OFFICE DEPOT		STORM DRAINAGE MAINTENA	82.94
	OFFICE DEPOT		TRANSPORTATION MANAGEM	134.89
	OFFICE DEPOT		WASTE WATER TREATMENT F	442.68
	OFFICE DEPOT	WORK FIT STATION	SOLID WASTE OPERATIONS	477.63
102887	OLSON, JENNIFER	UB 300600000002 5525 132ND ST	WATER/SEWER OPERATION	30.73
102888	ON SITE ELECTRIC LLC	FIXTURE AND OUTLET INSTALLATIO	MAINT OF GENL PLANT	1,305.60
	ON SITE ELECTRIC LLC	FIXTURE, OUTLET AND SWITCH INS	EQUIPMENT RENTAL	2,393.60
102889	OWEN EQUIPMENT	DEFLECTOR WELMENT HOPPER	EQUIPMENT RENTAL	673.95
102890	PAPE MACHINERY	FILTERS AND ELEMENTS	ER&R	91.19
102891	PARTS STORE, THE	WIPER REFILL CREDIT	EQUIPMENT RENTAL	-8.40
	PARTS STORE, THE		EQUIPMENT RENTAL	-8.40
	PARTS STORE, THE	WIPER BLADES	EQUIPMENT RENTAL	7.46
	PARTS STORE, THE	WATER PUMP INLET TUBE	EQUIPMENT RENTAL	9.56
	PARTS STORE, THE	GAS CAP	EQUIPMENT RENTAL	9.66
	PARTS STORE, THE	ACCESSORY BELT	EQUIPMENT RENTAL	16.56
	PARTS STORE, THE	WIPER REFILL	EQUIPMENT RENTAL	16.80
	PARTS STORE, THE	BRAKE PADS	EQUIPMENT RENTAL	35.66
	PARTS STORE, THE	SHIPPING EXPENSE	EQUIPMENT RENTAL	43.56
	PARTS STORE, THE	FILTERS	ER&R	65.32
	PARTS STORE, THE	SPARK PLUGS, WIRES AND PCV VAL	EQUIPMENT RENTAL	117.04
	PARTS STORE, THE	FILTERS	ER&R	204.47
	PARTS STORE, THE	SPARK PLUGS, BOOT AND EXHAUST	EQUIPMENT RENTAL	254.61
	PARTS STORE, THE	FILTERS	ER&R	514.01
102892	PAYMENTUS	TRANSACTION FEES-AUG 2015	UTILITY BILLING	15,223.78
102893	PEEBLES, RON & KARA	UB 840100810001 6631 81ST DR N	WATER/SEWER OPERATION	24.44
102894	PETROCARD SYSTEMS	FUEL CONSUMED	ENGR-GENL	40.78
	PETROCARD SYSTEMS		COMPUTER SERVICES	59.90
	PETROCARD SYSTEMS		STORM DRAINAGE	88.30
	PETROCARD SYSTEMS		EQUIPMENT RENTAL	109.65
	PETROCARD SYSTEMS		FACILITY MAINTENANCE	192.95
	PETROCARD SYSTEMS		COMMUNITY DEVELOPMENT-	422.28
	PETROCARD SYSTEMS		PARK & RECREATION FAC	765.67
	PETROCARD SYSTEMS		GENERAL SERVICES - OVERH	1,594.32
	PETROCARD SYSTEMS		SOLID WASTE OPERATIONS	2,811.93
	PETROCARD SYSTEMS		MAINT OF EQUIPMENT	3,249.06
	PETROCARD SYSTEMS		POLICE PATROL	6,398.96
102895	PGC INTERBAY LLC	PROFESSIONAL SERVICES	GOLF ADMINISTRATION	41.46
	PGC INTERBAY LLC		MAINTENANCE	148.88
	PGC INTERBAY LLC		GOLF ADMINISTRATION	156.31

DATE: 9/23/2015
TIME: 10:22:31AM

**CITY OF MARYSVILLE
INVOICE LIST**

PAGE: 5

FOR INVOICES FROM 9/17/2015 TO 9/23/2015

<u>CHK #</u>	<u>VENDOR</u>	<u>ITEM DESCRIPTION</u>	<u>ACCOUNT DESCRIPTION</u>	<u>ITEM AMOUNT</u>
102895	PGC INTERBAY LLC	PROFESSIONAL SERVICES	GOLF ADMINISTRATION	203.30
	PGC INTERBAY LLC		MAINTENANCE	270.98
	PGC INTERBAY LLC		MAINTENANCE	473.88
	PGC INTERBAY LLC		GOLF ADMINISTRATION	573.92
	PGC INTERBAY LLC		GOLF ADMINISTRATION	749.02
	PGC INTERBAY LLC		MAINTENANCE	1,795.35
	PGC INTERBAY LLC		MAINTENANCE	1,899.19
	PGC INTERBAY LLC		GOLF ADMINISTRATION	2,249.52
	PGC INTERBAY LLC		GOLF COURSE	2,816.04
	PGC INTERBAY LLC		GOLF COURSE	5,855.00
102896	PHAM, THANH NHI HUNG	UB 690042000000 3520 82ND PL N	WATER/SEWER OPERATION	128.81
102897	PHILIPS, SUPEE	JURY DUTY	COURTS	12.28
102898	PILCHUCK RENTALS	CHAINS, SLEEVES & HARDWARE	SMALL ENGINE SHOP	143.45
102899	PLANALP, SARAH	REFUND CLASS FEES	PARKS-RECREATION	60.00
102900	PUD	ACCT #2011-4209-8	PARK & RECREATION FAC	8.16
	PUD	ACCT #2054-8182-3	MAINTENANCE	15.53
	PUD	ACCT #2051-9537-3	PARK & RECREATION FAC	16.07
	PUD	ACCT #2020-1181-3	PUMPING PLANT	17.02
	PUD	ACCT #2000-6146-3	PARK & RECREATION FAC	24.80
	PUD	ACCT #2005-0161-7	TRANSPORTATION MANAGEM	25.33
	PUD	ACCT #2024-6102-6	MAINT OF GENL PLANT	32.67
	PUD	ACCT #2024-2648-2	PUBLIC SAFETY BLDG.	32.84
	PUD	ACCT #2027-9465-7	TRANSPORTATION MANAGEM	36.93
	PUD	ACCT #2022-9424-5	SEWER LIFT STATION	43.30
	PUD	ACCT #2009-7395-6	SEWER LIFT STATION	43.43
	PUD	ACCT #2035-0002-0	STREET LIGHTING	45.83
	PUD	ACCT #2025-2469-0	PUMPING PLANT	49.10
	PUD	ACCT #2006-6043-9	STREET LIGHTING	55.75
	PUD	ACCT #2022-8858-5	TRANSPORTATION MANAGEM	56.03
	PUD	ACCT #2023-0330-1	SEWER LIFT STATION	58.32
	PUD	ACCT #2039-9634-3	STREET LIGHTING	65.44
	PUD	ACCT #2011-4215-5	TRANSPORTATION MANAGEM	66.45
	PUD	ACCT #2004-4880-1	TRANSPORTATION MANAGEM	80.21
	PUD	ACCT #2031-9973-2	TRANSPORTATION MANAGEM	82.14
	PUD	ACCT#2021-7595-6	TRAFFIC CONTROL DEVICES	88.29
	PUD	ACCT #2020-0351-3	PUMPING PLANT	94.48
	PUD	ACCT #2032-9121-6	GENERAL SERVICES - OVERH	100.37
	PUD	ACCT #2052-3773-8	TRAFFIC CONTROL DEVICES	101.51
	PUD	ACCT #2052-3927-0	TRAFFIC CONTROL DEVICES	116.04
	PUD	ACCT #2019-0963-7	SEWER LIFT STATION	120.08
	PUD	ACCT #2016-2888-0	WASTE WATER TREATMENT F	121.38
	PUD	ACCT #2013-4666-5	SEWER LIFT STATION	198.65
	PUD	ACCT #2048-2122-7	TRAFFIC CONTROL DEVICES	253.63
	PUD	ACCT #2012-4769-9	STREET LIGHTING	281.28
	PUD	ACCT #2054-1976-5	PUBLIC SAFETY BLDG.	399.69
	PUD	ACCT #2024-6155-4	SEWER LIFT STATION	521.56
	PUD	ACCT #2016-7563-4	WASTE WATER TREATMENT F	577.88
	PUD	ACCT #2000-2187-1	COURT FACILITIES	1,186.97
	PUD	ACCT #2016-1747-9	ADMIN FACILITIES	1,377.03
	PUD	ACCT#2021-7733-3	MAINT OF GENL PLANT	1,535.21
	PUD	ACCT #2015-8728-4	WASTE WATER TREATMENT F	1,570.40
	PUD	ACCT #2016-3968-9	MAINT OF GENL PLANT	2,973.71
102901	PUGET SOUND ENERGY	ACCT #200007781657	PRO-SHOP	36.08
	PUGET SOUND ENERGY	ACCT #200004804056	COURT FACILITIES	41.65
102902	RANNEY, LAURA	WITNESS FEES	MUNICIPAL COURTS	11.14
102903	RAY, JONATHAN	JURY DUTY	COURTS	10.85
102904	RIEGER, ROD		COURTS	10.57
102905	ROMMEL, TERESA		COURTS	23.11
102906	ROY ROBINSON	TURN SIGNAL SWITCH AND LEVER	EQUIPMENT RENTAL	115.80
	ROY ROBINSON	BRAKE ROTORS AND BRAKE PADS	ER&R	381.24
102907	RRJ COMPANY LLC	PAY ESTIMATE #3	GMA-STREET	-15,634.51

DATE: 9/23/2015
TIME: 10:22:31AM

**CITY OF MARYSVILLE
INVOICE LIST**

PAGE: 6

FOR INVOICES FROM 9/17/2015 TO 9/23/2015

<u>CHK #</u>	<u>VENDOR</u>	<u>ITEM DESCRIPTION</u>	<u>ACCOUNT DESCRIPTION</u>	<u>ITEM AMOUNT</u>
102907	RRJ COMPANY LLC	PAY ESTIMATE #3	GMA - STREET	312,690.11
102908	RUSDEN, JOHN	PRO-TEM SERVICES	MUNICIPAL COURTS	185.00
	RUSDEN, JOHN		MUNICIPAL COURTS	740.00
	RUSDEN, JOHN		MUNICIPAL COURTS	1,480.00
102909	SNO-VALLEY FARMS INC	TILL FIELD	STORM DRAINAGE	10,880.00
	SNO-VALLEY FARMS INC	MOW AND TILL PARCEL #3	STORM DRAINAGE	13,056.00
102910	SONITROL	SECURITY SERVICES	UTIL ADMIN	133.00
	SONITROL		COMMUNITY CENTER	142.00
	SONITROL		PUBLIC SAFETY BLDG.	160.00
	SONITROL		PARK & RECREATION FAC	249.00
	SONITROL		MAINT OF GENL PLANT	286.00
	SONITROL		ADMIN FACILITIES	333.00
	SONITROL		WASTE WATER TREATMENT F	491.26
102911	SOUND PUBLISHING	EMPLOYMENT ADS	GENERAL SERVICES - OVERH	585.74
102912	SOUND SAFETY	HARD HATS W/LOGO	ER&R	527.90
102913	STAPLES	OFFICE SUPPLIES	COMMUNITY DEVELOPMENT-	1.69
	STAPLES		UTIL ADMIN	3.66
	STAPLES		ENGR-GENL	3.67
	STAPLES		ENGR-GENL	15.65
	STAPLES		UTIL ADMIN	15.65
	STAPLES		ENGR-GENL	32.62
102914	STELLING, MARRY	JURY DUTY	COURTS	15.70
102915	SUMMERFIELD, ANTHONY	UB 094837146000 4837 146TH PL	WATER/SEWER OPERATION	28.84
102916	SWICK-LAFAVE, JULIE	REIMBURSE JAIL SUPPLY EXPENSE	DETENTION & CORRECTION	165.48
102917	THERMAL SUPPLY INC.	ICE MACHINE AND STORAGE BIN	UTIL ADMIN	3,151.40
102918	THYSSENKRUPP ELEVATO	PREVENTATIVE MAINTENANCE	PUBLIC SAFETY BLDG.	212.23
	THYSSENKRUPP ELEVATO		ADMIN FACILITIES	212.23
102919	TIMEMARK INCORPORATE	CLAMPS, SPLICERS AND END PLUGS	TRANSPORTATION MANAGEM	150.76
102920	TRACY, TOM & NORMA	UB 761299050000 7733 76TH PL N	WATER/SEWER OPERATION	229.15
102921	TRAFFIC SAFETY SUPPL	POSTS AND ANCHOR/SLEEVES	TRANSPORTATION MANAGEM	2,102.56
102922	TREE TIME LLC	INSTRUCTOR SERVICES	RECREATION SERVICES	105.00
	TREE TIME LLC		RECREATION SERVICES	126.00
102923	TREGONING, KAREN	UB 611230000001 11831 38TH AVE	WATER/SEWER OPERATION	112.15
102924	UNITED PARCEL SERVIC	SHIPPING EXPENSE	POLICE PATROL	1.24
102925	US BANK NA^	UB 038113830000 8107 83RD PL N	WATER/SEWER OPERATION	22.08
102926	VANDERGRIEND, HARV &	UB 710620450001 8217 50TH AVE	WATER/SEWER OPERATION	255.07
102927	WETZEL, JAKE	REIMBURSE MEALS-TRAINING	TRAINING	10.44
102928	WILLIAMS, KATHERINE	RENTAL DEPOSIT REFUND	GENERAL FUND	100.00
102929	WILLIAMS, RYAN		GENERAL FUND	100.00
102930	WILSON, JOHN	JURY DUTY	COURTS	11.71
102931	WILSON, JULIE	REFUND CLASS FEES	PARKS-RECREATION	150.00
102932	WOMER & ASSOCIATES	FIRE SAFETY PLAN REVIEW	COMMUNITY DEVELOPMENT-	300.00
	WOMER & ASSOCIATES		COMMUNITY DEVELOPMENT-	300.00
	WOMER & ASSOCIATES		COMMUNITY DEVELOPMENT-	300.00
102933	WRIGHT, DONNA	REIMBURSE MILEAGE	CITY COUNCIL	40.41
102934	YMCA	POOL USAGE-JULY & AUG 2015	RECREATION SERVICES	120.00
102935	YOON, ERIK	JURY DUTY	COURTS	10.57
102936	YOUSIF, NADA MUSTAFA		COURTS	21.97
102937	ZEE MEDICAL SERVICE	RESTOCK FIRST AID SUPPLIES	COURT FACILITIES	110.56

WARRANT TOTAL:

903,453.65

Index #3

CITY OF MARYSVILLE

EXECUTIVE SUMMARY FOR ACTION

CITY COUNCIL MEETING DATE: October 12, 2015

AGENDA ITEM: Claims	AGENDA SECTION:	
PREPARED BY: Sandy Langdon, Finance Director	AGENDA NUMBER:	
ATTACHMENTS: Claims Listings	APPROVED BY:	
	MAYOR	CAO
BUDGET CODE:	AMOUNT:	

Please see attached.

RECOMMENDED ACTION:

The Finance and Executive Departments recommend City Council approve the **September 30, 2015** claims in the amount of **\$740,001.39** paid by **Check No. 102938 through 103119 with no Check No. voided.**

COUNCIL ACTION:

BLANKET CERTIFICATION
CLAIMS
FOR
PERIOD-9

I, THE UNDERSIGNED, DO HEREBY CERTIFY UNDER PENALTY OF PERJURY THAT THE MATERIALS HAVE BEEN FURNISHED, THE SERVICES RENDERED OR THE LABOR PERFORMED AS DESCRIBED HEREIN AND THAT THE **CLAIMS** IN THE AMOUNT OF **\$740,001.39 PAID BY CHECK NO.'S 102938 THROUGH 103119 WITH NO CHECK NO. VOIDED** ARE JUST, DUE AND UNPAID OBLIGATIONS AGAINST THE CITY OF MARYSVILLE, AND THAT I AM AUTHORIZED TO AUTHENTICATE AND TO CERTIFY SAID CLAIMS.

AUDITING OFFICER DATE

MAYOR DATE

WE, THE UNDERSIGNED COUNCIL MEMBERS OF MARYSVILLE, WASHINGTON DO HEREBY APPROVE FOR PAYMENT THE ABOVE MENTIONED **CLAIMS** ON THIS **12th DAY OF OCTOBER 2015.**

COUNCIL MEMBER

COUNCIL MEMBER

COUNCIL MEMBER

COUNCIL MEMBER

COUNCIL MEMBER

COUNCIL MEMBER

COUNCIL MEMBER

DATE: 9/30/2015
TIME: 10:48:24AM

**CITY OF MARYSVILLE
INVOICE LIST**

PAGE: 1

FOR INVOICES FROM 9/24/2015 TO 9/30/2015

<u>CHK #</u>	<u>VENDOR</u>	<u>ITEM DESCRIPTION</u>	<u>ACCOUNT DESCRIPTION</u>	<u>ITEM AMOUNT</u>
102938	3M	1177C GRN EC FILM	TRANSPORTATION MANAGEM	1,801.73
102939	AADVANTAGE PEST CONT	HORNET NEST REMOVAL	ROADSIDE VEGETATION	244.80
102940	ADVANCED TRAFFIC	PROGRAMMED LED LAMPS	TRANSPORTATION MANAGEM	878.84
102941	ALPINE PRODUCTS INC	WHITE THERMO	TRAFFIC CONTROL DEVICES	5,919.23
	ALPINE PRODUCTS INC		TRAFFIC CONTROL DEVICES	5,923.49
102942	ANDERSON, JERAD & TI	UB 141161300000 11613 44TH DR	WATER/SEWER OPERATION	64.30
102943	ARAMARK UNIFORM	UNIFORM SERVICE	SMALL ENGINE SHOP	4.15
	ARAMARK UNIFORM		SMALL ENGINE SHOP	4.15
	ARAMARK UNIFORM		EQUIPMENT RENTAL	38.83
	ARAMARK UNIFORM		EQUIPMENT RENTAL	39.10
102944	ARLINGTON POWER	MOWER REPAIR	ROADSIDE VEGETATION	51.68
	ARLINGTON POWER	TRIMMER REPAIR	ROADSIDE VEGETATION	54.94
	ARLINGTON POWER		ROADSIDE VEGETATION	57.12
	ARLINGTON POWER		ROADSIDE VEGETATION	57.12
	ARLINGTON POWER		ROADSIDE VEGETATION	60.93
	ARLINGTON POWER		ROADSIDE VEGETATION	65.82
	ARLINGTON POWER		ROADSIDE VEGETATION	71.16
	ARLINGTON POWER		ROADSIDE VEGETATION	95.37
	ARLINGTON POWER		ROADSIDE VEGETATION	121.20
102945	AV CAPTURE ALL, INC.	LEASE PAYMENT	PROBATION	646.27
	AV CAPTURE ALL, INC.		MUNICIPAL COURTS	1,938.82
102946	BERGER/ABAM ENGR	PROFESSIONAL SERVICES	GMA - STREET	5,264.65
102947	BHC CONSULTANTS		WASTE WATER TREATMENT F	9,035.61
102948	BICKFORD FORD	RETURN CIRCUIT BREAKER	EQUIPMENT RENTAL	-58.77
	BICKFORD FORD	CIRCUIT BREAKER	EQUIPMENT RENTAL	58.77
	BICKFORD FORD	PS PUMP	EQUIPMENT RENTAL	164.23
	BICKFORD FORD	RELAYS	ER&R	217.49
	BICKFORD FORD	SENDING UNITS	EQUIPMENT RENTAL	326.41
	BICKFORD FORD	INTAKE MANIFOLD, FAN, MODULE,	EQUIPMENT RENTAL	1,100.77
102949	BILLING DOCUMENT SPE	BILL PRINTING SERVICE	UTILITY BILLING	1,706.06
	BILLING DOCUMENT SPE		UTILITY BILLING	1,884.09
102950	BLACK ROCK CABLE INC	I-NET LEASE	CENTRAL SERVICES	536.93
102951	BNSF RAILWAY COMPANY	BORING WORK ALONG STATE AVE	GMA - STREET	839.82
	BNSF RAILWAY COMPANY	SURVEY FOR SAW CUT, CURB, AMP	GMA - STREET	5,569.35
102952	BOB BARKER COMPANY	INMATE SUPPLIES	DETENTION & CORRECTION	42.38
102953	BREACH, JARED	UB 848621790000 8621 79TH ST N	WATER/SEWER OPERATION	315.60
102954	BRINKS INC	ARMORED TRUCK SERVICE	COMMUNITY DEVELOPMENT-	100.69
	BRINKS INC		UTIL ADMIN	100.69
	BRINKS INC		GOLF ADMINISTRATION	183.60
	BRINKS INC		UTILITY BILLING	187.25
	BRINKS INC		POLICE ADMINISTRATION	360.44
	BRINKS INC		MUNICIPAL COURTS	360.44
102955	BROWN, CANDIS	INSTRUCTOR SERVICES	RECREATION SERVICES	91.80
102956	BUELL, LARRY	MEAL REIMBURSEMENT-TRAINING	POLICE ADMINISTRATION	151.32
102957	CARDWELL, IRATXE	INTERPRETER SERVICES	COURTS	100.00
102958	CARRS ACE	SPADING FORK	PARK & RECREATION FAC	30.45
102959	CASCADE NATURAL GAS	NATURAL GAS CHARGES	WATER FILTRATION PLANT	37.40
102960	CASTRO, CHRISTINA	RENTAL DEPOSIT REFUND	GENERAL FUND	100.00
102961	CEMEX	ASPHALT	ROADWAY MAINTENANCE	344.67
	CEMEX		WATER SERVICES	346.73
	CEMEX		ROADWAY MAINTENANCE	584.08
102962	CHEMTRADE CHEMICALS	ALUMINUM SULFATE	WASTE WATER TREATMENT F	4,029.95
	CHEMTRADE CHEMICALS		WASTE WATER TREATMENT F	4,061.28
102963	CHRISTENSEN, TERRIE	UB 851440000000 8313 56TH DR N	WATER/SEWER OPERATION	82.38
102964	CITRIX ONLINE LLC	GOTOMEETING LICENSES	COMPUTER SERVICES	1,599.36
102965	CLARK, HOPE	RENTAL DEPOSIT REFUND	GENERAL FUND	100.00
102966	CLEAN CUT TREE & STU	TREE REMOVAL	PARK & RECREATION FAC	136.00
	CLEAN CUT TREE & STU		PARK & RECREATION FAC	244.80
	CLEAN CUT TREE & STU		PARK & RECREATION FAC	272.00
	CLEAN CUT TREE & STU		PARK & RECREATION FAC	979.20
	CLEAN CUT TREE & STU		PARK & RECREATION FAC	1,196.80

DATE: 9/30/2015
TIME: 10:48:24AM

**CITY OF MARYSVILLE
INVOICE LIST**

PAGE: 2

FOR INVOICES FROM 9/24/2015 TO 9/30/2015

<u>CHK #</u>	<u>VENDOR</u>	<u>ITEM DESCRIPTION</u>	<u>ACCOUNT DESCRIPTION</u>	<u>ITEM AMOUNT</u>
102966	CLEAN CUT TREE & STU	TREE REMOVAL	PARK & RECREATION FAC	1,305.60
102967	COLUMBIA FORD	2015 FORD P2L POLICE SEDAN FWD	EQUIPMENT RENTAL	28,337.05
	COLUMBIA FORD	2016 FORD K8A POLICE UTILITY A	EQUIPMENT RENTAL	32,137.30
	COLUMBIA FORD	2016 FORD 4X4 C&C DRW	EQUIPMENT RENTAL	35,287.74
	COLUMBIA FORD	2015 FORD W2C TRANSIT CARGO	EQUIPMENT RENTAL	42,684.63
102968	COMCAST	CABLE SERVICE-KBCC	BAXTER CENTER APPRE	61.00
	COMCAST	MONTHLY BROADBAND CHARGES	COMPUTER SERVICES	253.99
102969	COOP SUPPLY	ODORIZER	PARK & RECREATION FAC	27.19
	COOP SUPPLY	PROPANE TORCH	ROADWAY MAINTENANCE	54.39
	COOP SUPPLY	K-9 FOOD	K9 PROGRAM	59.83
	COOP SUPPLY	K-9 FOOD	K9 PROGRAM	59.83
	COOP SUPPLY	STAKES	PARK & RECREATION FAC	86.82
102970	COPIERS NORTHWEST	PRINTER LEASE	OFFICE OPERATIONS	1,930.15
102971	COREY, KIMBERLY	UB 790111420001 6305 55TH PL N	WATER/SEWER OPERATION	22.69
102972	CORNWELL TOOLS	GAUGES	EQUIPMENT RENTAL	150.08
102973	CORRECTIONS, DEPT OF	INMATE MEALS	DETENTION & CORRECTION	2,446.96
	CORRECTIONS, DEPT OF		DETENTION & CORRECTION	3,556.45
	CORRECTIONS, DEPT OF		DETENTION & CORRECTION	4,245.64
102974	COSTELLO, HEATHER	REFUND CLASS FEES	PARKS-RECREATION	90.00
102975	COWEN, STEPHEN	UB 426191640000 619 164TH ST N	WATER/SEWER OPERATION	22.99
102976	CRAFT MART	SPECIAL EVENT SUPPLIES	RECREATION SERVICES	41.32
102977	CUZ CONCRETE PROD	CATCH BASIN AND CAPS	STORM DRAINAGE	314.40
102978	DANIELS, ERIC	UB 985216000001 5216 61ST DR N	WATER/SEWER OPERATION	68.66
102979	DAVIS, ARTHUR & JENN	UB 986565000001 5900 64TH ST N	GARBAGE	336.34
102980	DELL	MONITORS	SOLID WASTE OPERATIONS	424.30
102981	DICKS TOWING	TOWING EXPENSE	EQUIPMENT RENTAL	43.52
	DICKS TOWING	TOWING EXPENSE-731-YPQ	POLICE PATROL	43.52
	DICKS TOWING	TOWING EXPENSE-ADW1988	POLICE PATROL	43.52
	DICKS TOWING	TOWING EXPENSE-AUD0814	POLICE PATROL	43.52
	DICKS TOWING	TOWING EXPENSE-MP15-6471	POLICE PATROL	43.52
	DICKS TOWING	TOWING EXPENSE-MP15-6953	POLICE PATROL	43.52
	DICKS TOWING	TOWING EXPENSE-MP15-6956	POLICE PATROL	43.52
	DICKS TOWING	TOWING EXPENSE-MP15-6992	POLICE PATROL	43.52
	DICKS TOWING	TOWING EXPENSE-MP15-7058	POLICE PATROL	43.52
	DICKS TOWING	TOWING EXPENSE-MP15-7250	POLICE PATROL	43.52
	DICKS TOWING	TOWING EXPENSE-MP15-7302	POLICE PATROL	43.52
	DICKS TOWING	TOWING EXPENSE-MP15-7303	POLICE PATROL	43.52
102982	DIVERSIFIED INVESTOR	UB 741362000000 5900 54TH AVE	GARBAGE	8.46
102983	DONALDSON, BRENDA	REIMBURSE RECORDING FEES/BINS/	UTIL ADMIN	18.16
	DONALDSON, BRENDA		STORM DRAINAGE	73.00
	DONALDSON, BRENDA		ENGR-GENL	125.00
102984	DOPPS, MARIA C.	INTERPRETER SERVICES	COURTS	104.57
102985	DREYER, STACEY	REIMBURSE SHED REPAIR COSTS	POLICE PATROL	128.58
102986	DUNLAP INDUSTRIAL	RATCHET STRAPS	ROADWAY MAINTENANCE	179.74
102987	E&E LUMBER	HOOK	PARK & RECREATION FAC	3.53
	E&E LUMBER	CAUTION TAPE	PARK & RECREATION FAC	14.61
	E&E LUMBER	CLEANING SUPPLIES	PARK & RECREATION FAC	15.95
	E&E LUMBER	CAUTION TAPE	PARK & RECREATION FAC	25.02
	E&E LUMBER	PAINT BRUSH AND HOOK & LATCH	PARK & RECREATION FAC	32.36
	E&E LUMBER	STRAPS AND CLEANER	PARK & RECREATION FAC	35.82
	E&E LUMBER	HOOKS AND BRACKETS	MAINT OF GENL PLANT	37.81
	E&E LUMBER	PAINT AND SPONGES	STORM DRAINAGE	47.32
	E&E LUMBER	HARDWARE	MAINT OF GENL PLANT	51.78
	E&E LUMBER	DECK BOARDS	EQUIPMENT RENTAL	100.27
	E&E LUMBER	FREEZE CONTROL SUPPLIES	WASTE WATER TREATMENT F	195.27
	E&E LUMBER	LUMBER, TIP AND CAUTION TAPE	PARK & RECREATION FAC	223.68
102988	EAGLE FENCE	GATE ROLLER REPAIR	MAINT OF GENL PLANT	73.99
102989	ELLIOTT, DANIELLE	REIMBURSE JIS TRAINING EXPENSE	MUNICIPAL COURTS	835.38
102990	EMERALD RECYCLING	DISPOSAL FEES	EQUIPMENT RENTAL	132.50
102991	ENVIRONMENTAL CONTRO	JANITORIAL SERVICES	WATER FILTRATION PLANT	56.65
	ENVIRONMENTAL CONTRO		WATER FILTRATION PLANT	56.65

DATE: 9/30/2015
TIME: 10:48:24AM

**CITY OF MARYSVILLE
INVOICE LIST
FOR INVOICES FROM 9/24/2015 TO 9/30/2015**

PAGE: 3

<u>CHK #</u>	<u>VENDOR</u>	<u>ITEM DESCRIPTION</u>	<u>ACCOUNT DESCRIPTION</u>	<u>ITEM AMOUNT</u>
102991	ENVIRONMENTAL CONTRO	JANITORIAL SERVICES	PARK & RECREATION FAC	500.37
	ENVIRONMENTAL CONTRO		PARK & RECREATION FAC	500.37
	ENVIRONMENTAL CONTRO		COMMUNITY CENTER	566.46
	ENVIRONMENTAL CONTRO		COMMUNITY CENTER	566.46
	ENVIRONMENTAL CONTRO		WASTE WATER TREATMENT F	679.75
	ENVIRONMENTAL CONTRO		WASTE WATER TREATMENT F	679.75
	ENVIRONMENTAL CONTRO		UTIL ADMIN	1,132.91
	ENVIRONMENTAL CONTRO		UTIL ADMIN	1,132.91
	ENVIRONMENTAL CONTRO		MAINT OF GENL PLANT	1,594.47
	ENVIRONMENTAL CONTRO		MAINT OF GENL PLANT	1,594.47
	ENVIRONMENTAL CONTRO		COURT FACILITIES	1,699.37
	ENVIRONMENTAL CONTRO		COURT FACILITIES	1,699.37
	ENVIRONMENTAL CONTRO		PUBLIC SAFETY BLDG.	1,790.00
	ENVIRONMENTAL CONTRO		PUBLIC SAFETY BLDG.	1,790.00
	ENVIRONMENTAL CONTRO		ADMIN FACILITIES	1,978.51
	ENVIRONMENTAL CONTRO		ADMIN FACILITIES	1,978.51
102992	ENVIRONMENTAL RES	PROFICIENCY TESTING	WATER/SEWER OPERATION	-39.65
	ENVIRONMENTAL RES		WASTE WATER TREATMENT F	490.19
102993	EVERETT STAMP WORKS	ELECTRICAL PANE/METER LABELS (COMMUNITY DEVELOPMENT-	1,559.92
102994	EVERETT, CITY OF	LAB ANALYSIS	WASTE WATER TREATMENT F	291.60
	EVERETT, CITY OF	ANIMAL SHELTER FEES-AUG 2015	ANIMAL CONTROL	6,090.00
102995	FLOYD, CHRIS	INSTRUCTOR SERVICES	RECREATION SERVICES	72.00
	FLOYD, CHRIS		RECREATION SERVICES	120.00
102996	FOREMOST PROMOTIONS	SUPPLIES	GENERAL FUND	-46.64
	FOREMOST PROMOTIONS		CRIME PREVENTION	576.54
102997	FRED PRYOR SEMINARS	TRAINING-DAY	SOLID WASTE OPERATIONS	299.00
	FRED PRYOR SEMINARS	TRAINING-DOUGLAS	SOLID WASTE OPERATIONS	299.00
102998	FRONTIER COMMUNICATI	ACCT #36065125170927115	STREET LIGHTING	46.42
	FRONTIER COMMUNICATI	ACCT #42539763250319985	PARK & RECREATION FAC	53.46
	FRONTIER COMMUNICATI	ACCT #36065831360617105	MUNICIPAL COURTS	66.15
	FRONTIER COMMUNICATI	ACCT #36065962121015935	MAINT OF GENL PLANT	66.15
	FRONTIER COMMUNICATI	ACCT #36065976670111075	OFFICE OPERATIONS	66.15
	FRONTIER COMMUNICATI	ACCT #36065827660617105	MUNICIPAL COURTS	66.32
	FRONTIER COMMUNICATI	ACCT #25300981920624965	SEWER LIFT STATION	88.01
	FRONTIER COMMUNICATI	ACCT #36065191230801065	WATER FILTRATION PLANT	97.52
102999	FULLERTON & ASSOCIAT	1ST STREET IMPROVEMENT PROJECT	GMA - STREET	2,490.00
103000	GALLS, LLC	UNIFORM-LESTER	OFFICE OPERATIONS	141.36
	GALLS, LLC	VEST-MORTON	POLICE PATROL	1,097.73
103001	GAMETIME	PLAYGROUND EQUIP REPAIR	PARK & RECREATION FAC	536.72
103002	GEOTEST SERVICES INC	TESTING AND INSPECTION	GMA - STREET	787.30
103003	GESSNER, KRISTA	REIMBURSE TRAINING EXPENSE	UTIL ADMIN	87.00
103004	GREENHAUS PORTABLE	PORTABLE RENTALS	RECREATION SERVICES	258.50
	GREENHAUS PORTABLE		PARK & RECREATION FAC	500.50
	GREENHAUS PORTABLE		RECREATION SERVICES	605.00
103005	GREENSHIELDS	WASHRACK REPAIR PARTS	MAINT OF GENL PLANT	110.44
	GREENSHIELDS	HOSE REPAIR PARTS	STORM DRAINAGE	174.83
103006	GUNDERSON, JARL	LEOFF 1 REIMBURSEMENT	POLICE ADMINISTRATION	847.19
103007	HACH COMPANY	BOD NUT PILLOWS	WASTE WATER TREATMENT F	581.46
103008	HD FOWLER COMPANY	COUPLING	SOURCE OF SUPPLY	14.33
	HD FOWLER COMPANY	COUPLINGS	SOURCE OF SUPPLY	72.85
	HD FOWLER COMPANY	PUMP SUPPLIES	WASTE WATER TREATMENT F	95.30
	HD FOWLER COMPANY	METER SETTER	WATER/SEWER OPERATION	336.30
103009	HD SUPPLY WATERWORKS	STEM AND HYDRANT REPAIR KIT	HYDRANTS	413.30
103010	HDR ENGINEERING	PROFESSIONAL SERVICES	GMA - STREET	6,135.21
103011	HERMANN, DERECK	UB 760960216301 6716 59TH ST N	WATER/SEWER OPERATION	360.68
103012	HILL, JODY	REFUND CLASS FEES	PARKS-RECREATION	152.00
103013	HIMALAYA HOMES-RENTA	UB 983025000000 3025 72ND AVE	WATER/SEWER OPERATION	493.82
103014	HOBBS, JAMES & LARIS	UB 980000012501 8205 30TH PL N	WATER/SEWER OPERATION	418.92
103015	HOYT, LANA	UB 980470500003 4705 60TH DR N	WATER/SEWER OPERATION	20.40
103016	HUSKY DOOR CORP	DOOR AND CASING	ADMIN FACILITIES	439.85
103017	HYLARIDES, LETTIE	INTERPRETER SERVICES	COURTS	112.50

DATE: 9/30/2015
TIME: 10:48:24AM

**CITY OF MARYSVILLE
INVOICE LIST**

PAGE: 4

FOR INVOICES FROM 9/24/2015 TO 9/30/2015

<u>CHK #</u>	<u>VENDOR</u>	<u>ITEM DESCRIPTION</u>	<u>ACCOUNT DESCRIPTION</u>	<u>ITEM AMOUNT</u>
103017	HYLARIDES, LETTIE	INTERPRETER SERVICES	COURTS	112.50
103018	INDUSTRIAL CONTROLS	RELAY POLES	WATER RESERVOIRS	215.14
103019	JANEWAY, STEPHANIE	REFUND CLASS FEES	PARKS-RECREATION	131.87
103020	JOSSY, DUSTYN	UB 245831122000 5831 122ND PL	WATER/SEWER OPERATION	32.33
103021	KENWORTH NORTHWEST	REPAIR 2004 PETE CID	EQUIPMENT RENTAL	7,808.82
103022	KPG, INC PS	PROFESSIONAL SERVICES	GMA - STREET	296.01
103023	KUKER-RANKEN KUKER-RANKEN	SURVEYING SUPPLIES	ENGR-GENL	487.82
			ENGR-GENL	552.43
103024	KUPRIYANOVA, SVETLAN	INTERPRETER SERVICES	COURTS	150.00
103025	LAB/COR, INC.	LAB ANALYSIS	WATER QUAL TREATMENT	810.00
103026	LASTING IMPRESSIONS LASTING IMPRESSIONS	UNIFORM-GERFIN BEANIES W/LOGO	POLICE PATROL	51.68
			ER&R	259.68
103027	LES SCHWAB TIRE CTR LES SCHWAB TIRE CTR	TIRE TIRES	ER&R	252.09
			ER&R	680.64
103028	LEWIS, MIKE	REIMBURSE CDL RENEWAL FEES	FACILITY MAINTENANCE	102.00
103029	LW PRODUCTS CO	T HANDLE KEYS	SEWER LIFT STATION	107.06
103030	MARATHON EQUIPMENT MARATHON EQUIPMENT	SLEEVEING AND HOSE COVERS	ER&R	-70.32
			EQUIPMENT RENTAL	869.42
103031	MARK SUN PROPERTY MG	UB 790390000004 5816 66TH AVE	WATER/SEWER OPERATION	25.85
103032	MARYSVILLE AWARDS	PLAQUE	PARK & RECREATION FAC	212.15
103033	MARYSVILLE PRINTING	BUSINESS CARDS FOR OPERA HOUSE	OPERA HOUSE	59.30
	MARYSVILLE PRINTING	ENVELOPES	COMMUNITY CENTER	66.89
	MARYSVILLE PRINTING	BUSINESS CARDS	CRIME PREVENTION	73.49
	MARYSVILLE PRINTING	BASKETBALL FLYERS	RECREATION SERVICES	86.89
	MARYSVILLE PRINTING	SPECIAL EVENT/BASKETBALL/HOLID	COMMUNITY CENTER	153.70
	MARYSVILLE PRINTING		COMMUNITY EVENTS	153.70
	MARYSVILLE PRINTING		COMMUNITY EVENTS	153.72
	MARYSVILLE PRINTING	NEW REMIT ADDRESS NOTICES	UTILITY BILLING	174.08
	MARYSVILLE PRINTING	ENVELOPES	FINANCE-GENL	176.80
	MARYSVILLE PRINTING	SPECIAL EVENT/BASKETBALL/HOLID	RECREATION SERVICES	461.11
	MARYSVILLE PRINTING	NEW REMIT ADDRESS NOTICES	UTILITY BILLING	1,528.64
103034	MARYSVILLE SCHOOL	FACILITY USAGE FEES-ACE	RECREATION SERVICES	27.00
	MARYSVILLE SCHOOL	FACILITY USAGE FEES-TMS	RECREATION SERVICES	36.00
	MARYSVILLE SCHOOL	FACILITY USAGE FEES-GETCHELL H	COMMUNITY EVENTS	88.00
	MARYSVILLE SCHOOL	FACILITY USAGE FEES-MPHS	RECREATION SERVICES	96.00
	MARYSVILLE SCHOOL	FACILITY USAGE FEES-TMS	RECREATION SERVICES	204.00
	MARYSVILLE SCHOOL		RECREATION SERVICES	492.00
	MARYSVILLE SCHOOL	FACILITY USAGE FEES-ACE (SUMME	RECREATION SERVICES	1,698.00
103035	MCFADDEN, KEELY	UB 768513610000 8513 61ST PL N	WATER/SEWER OPERATION	15.62
103036	MCLOUGHLIN & EARDLEY	PATROL CAR OUTFITTING EQUIPMEN	ER&R	-415.86
	MCLOUGHLIN & EARDLEY		ER&R	-198.97
	MCLOUGHLIN & EARDLEY		ER&R	-194.40
	MCLOUGHLIN & EARDLEY		ER&R	-125.66
	MCLOUGHLIN & EARDLEY		ER&R	-114.80
	MCLOUGHLIN & EARDLEY		ER&R	-27.66
	MCLOUGHLIN & EARDLEY		ER&R	-27.07
	MCLOUGHLIN & EARDLEY		EQUIPMENT RENTAL	47.81
	MCLOUGHLIN & EARDLEY		EQUIPMENT RENTAL	47.81
	MCLOUGHLIN & EARDLEY		EQUIPMENT RENTAL	47.82
	MCLOUGHLIN & EARDLEY		EQUIPMENT RENTAL	47.82
	MCLOUGHLIN & EARDLEY		EQUIPMENT RENTAL	47.82
	MCLOUGHLIN & EARDLEY		EQUIPMENT RENTAL	47.82
	MCLOUGHLIN & EARDLEY		EQUIPMENT RENTAL	47.82
	MCLOUGHLIN & EARDLEY		EQUIPMENT RENTAL	85.49
	MCLOUGHLIN & EARDLEY		EQUIPMENT RENTAL	85.49
	MCLOUGHLIN & EARDLEY		EQUIPMENT RENTAL	85.50
	MCLOUGHLIN & EARDLEY		EQUIPMENT RENTAL	85.50
	MCLOUGHLIN & EARDLEY		EQUIPMENT RENTAL	221.94
	MCLOUGHLIN & EARDLEY		EQUIPMENT RENTAL	221.94
	MCLOUGHLIN & EARDLEY		EQUIPMENT RENTAL	221.94
	MCLOUGHLIN & EARDLEY		EQUIPMENT RENTAL	221.94

DATE: 9/30/2015
TIME: 10:48:24AM

**CITY OF MARYSVILLE
INVOICE LIST
FOR INVOICES FROM 9/24/2015 TO 9/30/2015**

PAGE: 5

<u>CHK #</u>	<u>VENDOR</u>	<u>ITEM DESCRIPTION</u>	<u>ACCOUNT DESCRIPTION</u>	<u>ITEM AMOUNT</u>
103036	MCLOUGHLIN & EARDLEY	PATROL CAR OUTFITTING EQUIPMEN	EQUIPMENT RENTAL	221.94
	MCLOUGHLIN & EARDLEY		EQUIPMENT RENTAL	221.94
	MCLOUGHLIN & EARDLEY		EQUIPMENT RENTAL	221.95
	MCLOUGHLIN & EARDLEY		EQUIPMENT RENTAL	343.30
	MCLOUGHLIN & EARDLEY		EQUIPMENT RENTAL	343.36
	MCLOUGHLIN & EARDLEY		EQUIPMENT RENTAL	343.36
	MCLOUGHLIN & EARDLEY		EQUIPMENT RENTAL	343.36
	MCLOUGHLIN & EARDLEY		EQUIPMENT RENTAL	343.36
	MCLOUGHLIN & EARDLEY		EQUIPMENT RENTAL	343.36
	MCLOUGHLIN & EARDLEY		EQUIPMENT RENTAL	343.36
	MCLOUGHLIN & EARDLEY		EQUIPMENT RENTAL	351.39
	MCLOUGHLIN & EARDLEY		EQUIPMENT RENTAL	351.43
	MCLOUGHLIN & EARDLEY		EQUIPMENT RENTAL	351.43
	MCLOUGHLIN & EARDLEY		EQUIPMENT RENTAL	351.43
	MCLOUGHLIN & EARDLEY		EQUIPMENT RENTAL	351.43
	MCLOUGHLIN & EARDLEY		EQUIPMENT RENTAL	351.43
	MCLOUGHLIN & EARDLEY		EQUIPMENT RENTAL	351.43
	MCLOUGHLIN & EARDLEY		EQUIPMENT RENTAL	354.82
	MCLOUGHLIN & EARDLEY		EQUIPMENT RENTAL	354.82
	MCLOUGHLIN & EARDLEY		EQUIPMENT RENTAL	354.83
	MCLOUGHLIN & EARDLEY		EQUIPMENT RENTAL	354.83
	MCLOUGHLIN & EARDLEY		EQUIPMENT RENTAL	734.51
	MCLOUGHLIN & EARDLEY		EQUIPMENT RENTAL	734.51
	MCLOUGHLIN & EARDLEY		EQUIPMENT RENTAL	734.51
	MCLOUGHLIN & EARDLEY		EQUIPMENT RENTAL	734.51
	MCLOUGHLIN & EARDLEY		EQUIPMENT RENTAL	734.51
	MCLOUGHLIN & EARDLEY		EQUIPMENT RENTAL	734.51
	MCLOUGHLIN & EARDLEY		EQUIPMENT RENTAL	734.52
	MCLOUGHLIN & EARDLEY		EQUIPMENT RENTAL	734.52
103037	MICRO DATA	INFRACTION AND CITATION FORMS	POLICE PATROL	1,453.98
103038	MILES, BEVERLY	UB 14138000001 4221 123RD PL	WATER/SEWER OPERATION	22.81
103039	MILLER, TARA	RENTAL DEPOSIT REFUND	GENERAL FUND	200.00
103040	MINCHUK, DMITRIY & N	UB 757246530000 7246 53RD ST N	WATER/SEWER OPERATION	130.20
103041	MISHLER, BRONLEA	REIMBURSE TRAVEL EXPENSES	EXECUTIVE ADMIN	230.00
103042	MORGAN SOUND	AUDIO SYSTEM REPAIRS	MUNICIPAL COURTS	277.44
103043	MORRISON, AMY	REFUND CLASS FEES	PARKS-RECREATION	25.00
103044	MORRISON, RYAN	REIMBURSE GIFT CARD PURCHASE-W	PERSONNEL ADMINISTRATIO	100.00
103045	MOTOR TRUCKS	TURN SIGNAL MULTIFUNCTION SWIT	EQUIPMENT RENTAL	133.08
103046	MOTOROLA	PATROL CAR OUTFITTING EQUIPMEN	EQUIPMENT RENTAL	3,498.46
	MOTOROLA		EQUIPMENT RENTAL	3,498.46
	MOTOROLA		EQUIPMENT RENTAL	3,498.46
	MOTOROLA		EQUIPMENT RENTAL	3,498.46
	MOTOROLA		EQUIPMENT RENTAL	3,498.47
	MOTOROLA		EQUIPMENT RENTAL	3,498.47
	MOTOROLA		EQUIPMENT RENTAL	3,498.47
103047	MOUNT, HERMAN	LEOFF 1 REIMBURSEMENT	POLICE ADMINISTRATION	629.40
103048	NATIONAL BARRICADE	ORANGE CONES	ROADWAY MAINTENANCE	1,601.85
103049	NATIONAL FIRE PROTEC	MEMBERSHIP DUES-DORCAS	COMMUNITY DEVELOPMENT-	300.00
103050	NC MACHINERY COMPANY	GRINDER HEADS AND BIT HOLDERS	ROADWAY MAINTENANCE	512.98
103051	NEWMAN TRAFFIC SIGNS	DEAD END SIGNS	CITY STREETS	-78.99
	NEWMAN TRAFFIC SIGNS		TRANSPORTATION MANAGEM	976.63
103052	NORTHSTAR CHEMICAL	SODIUM HYPOCHLORITE	WASTE WATER TREATMENT F	2,614.90
	NORTHSTAR CHEMICAL		WASTE WATER TREATMENT F	3,175.00
	NORTHSTAR CHEMICAL		WASTE WATER TREATMENT F	3,505.97
103053	NORTHWESTERN AUTO	BODY REPAIR TO 2006 FORD	EQUIPMENT RENTAL	315.52
103054	NW PROPERTY MANAGEME	UB 849000524102 6514 79TH PL N	WATER/SEWER OPERATION	157.15
103055	OATES, DEREK	REIMBURSE SHED REPLACEMENT ITE	POLICE PATROL	184.63
103056	OFFICE DEPOT	OFFICE SUPPLY CREDIT	EXECUTIVE ADMIN	-68.47
	OFFICE DEPOT	OFFICE SUPPLIES	COMPUTER SERVICES	5.93
	OFFICE DEPOT		POLICE PATROL	6.14
	OFFICE DEPOT		FINANCE-GENL	6.29
	OFFICE DEPOT		POLICE PATROL	13.12

DATE: 9/30/2015
TIME: 10:48:24AM

**CITY OF MARYSVILLE
INVOICE LIST
FOR INVOICES FROM 9/24/2015 TO 9/30/2015**

PAGE: 6

<u>CHK #</u>	<u>VENDOR</u>	<u>ITEM DESCRIPTION</u>	<u>ACCOUNT DESCRIPTION</u>	<u>ITEM AMOUNT</u>
103056	OFFICE DEPOT	OFFICE SUPPLIES	POLICE INVESTIGATION	13.40
	OFFICE DEPOT		COMPUTER SERVICES	20.66
	OFFICE DEPOT		POLICE INVESTIGATION	26.86
	OFFICE DEPOT		COMPUTER SERVICES	30.36
	OFFICE DEPOT		LEGAL - PROSECUTION	39.16
	OFFICE DEPOT		POLICE INVESTIGATION	48.43
	OFFICE DEPOT		POLICE INVESTIGATION	51.13
	OFFICE DEPOT		LEGAL - PROSECUTION	80.11
	OFFICE DEPOT		CITY CLERK	80.82
	OFFICE DEPOT		POLICE INVESTIGATION	81.34
	OFFICE DEPOT		POLICE PATROL	82.67
	OFFICE DEPOT		POLICE PATROL	85.66
	OFFICE DEPOT		LEGAL - PROSECUTION	115.30
	OFFICE DEPOT		POLICE INVESTIGATION	132.50
	OFFICE DEPOT		POLICE PATROL	152.28
	OFFICE DEPOT		POLICE PATROL	189.52
	OFFICE DEPOT	CUPS	DETENTION & CORRECTION	344.24
	OFFICE DEPOT	OFFICE SUPPLIES	FINANCE-GENL	400.20
103057	PACIFIC NW BUSINESS	TONER	MUNICIPAL COURTS	400.27
103058	PARTS STORE, THE	BRAKE PAD CREDIT	EQUIPMENT RENTAL	-99.90
	PARTS STORE, THE	OIL SEAL CREDIT	ER&R	-42.83
	PARTS STORE, THE	SPARK PLUG	EQUIPMENT RENTAL	5.93
	PARTS STORE, THE	OIL SEAL AND LUBE GAURD	EQUIPMENT RENTAL	19.12
	PARTS STORE, THE	INTERIOR DOOR HANDLE	EQUIPMENT RENTAL	19.14
	PARTS STORE, THE	SERPENTINE BELT	EQUIPMENT RENTAL	32.48
	PARTS STORE, THE	INTERIOR DOOR HANDLES	EQUIPMENT RENTAL	38.28
	PARTS STORE, THE	WIRE SET	EQUIPMENT RENTAL	40.46
	PARTS STORE, THE	BRAKE PADS	EQUIPMENT RENTAL	62.16
	PARTS STORE, THE	FUEL INJECTORS	EQUIPMENT RENTAL	100.49
	PARTS STORE, THE	BRAKE ROTORS, BRAKE PADS, DRUM	EQUIPMENT RENTAL	277.23
	PARTS STORE, THE	BRAKE ROTORS AND BRAKE PADS	EQUIPMENT RENTAL	502.20
103059	PAYDIRT, LLC	STEEL PLATES	SOURCE OF SUPPLY	228.48
103060	PEACE OF MIND	MINUTE TAKING SERVICE	CITY CLERK	124.00
	PEACE OF MIND		COMMUNITY DEVELOPMENT-	139.50
103061	PGC INTERBAY LLC	GOLF COURSE PAYROLL	PRO-SHOP	62.85
	PGC INTERBAY LLC		MAINTENANCE	62.85
	PGC INTERBAY LLC		PRO-SHOP	86.64
	PGC INTERBAY LLC		PRO-SHOP	105.36
	PGC INTERBAY LLC		PRO-SHOP	114.32
	PGC INTERBAY LLC		MAINTENANCE	145.82
	PGC INTERBAY LLC		MAINTENANCE	177.85
	PGC INTERBAY LLC		PRO-SHOP	213.04
	PGC INTERBAY LLC		PRO-SHOP	250.58
	PGC INTERBAY LLC		MAINTENANCE	250.85
	PGC INTERBAY LLC		MAINTENANCE	452.84
	PGC INTERBAY LLC		PRO-SHOP	472.41
	PGC INTERBAY LLC		MAINTENANCE	1,016.80
	PGC INTERBAY LLC		PRO-SHOP	6,090.98
	PGC INTERBAY LLC		MAINTENANCE	12,926.75
103062	PHAM, JOSEPH	INTERPETER SERVICES	COURTS	125.00
103063	PHELPS TIRE CO INC.	TIRES	EQUIPMENT RENTAL	1,618.05
103064	PIGSKIN UNIFORMS	JACKET-THOMPSON	POLICE PATROL	379.75
103065	PILCHUCK RENTALS	NOZZLE	PARK & RECREATION FAC	92.43
	PILCHUCK RENTALS	CHAINS, WRENCHES AND FILES	ROADSIDE VEGETATION	96.34
	PILCHUCK RENTALS	CHAPS WRAP AND APRON	ROADSIDE VEGETATION	193.56
103066	PLATT ELECTRIC	MISC TOOLS	COMMUNITY DEVELOPMENT-	13.77
	PLATT ELECTRIC	BULBS	MAINT OF GENL PLANT	50.27
	PLATT ELECTRIC	BALLASTS	ADMIN FACILITIES	56.92
	PLATT ELECTRIC	MISC TOOLS	COMMUNITY DEVELOPMENT-	77.44
	PLATT ELECTRIC	BULBS	WATER QUAL TREATMENT	89.03
	PLATT ELECTRIC		COURT FACILITIES	138.39

DATE: 9/30/2015
TIME: 10:48:24AM

**CITY OF MARYSVILLE
INVOICE LIST**

PAGE: 7

FOR INVOICES FROM 9/24/2015 TO 9/30/2015

<u>CHK #</u>	<u>VENDOR</u>	<u>ITEM DESCRIPTION</u>	<u>ACCOUNT DESCRIPTION</u>	<u>ITEM AMOUNT</u>
103067	PORTER, ANDREW	INSTRUCTOR SERVICES	COMMUNITY CENTER	72.00
103068	POSITIVE CONCEPTS IN POSITIVE CONCEPTS IN	SECTOR PAPER	GENERAL FUND	-43.12
103069	PRECISION CONCRETE	TRIP HAZARD PROGRAM REPAIRS	POLICE PATROL	533.12
103070	PREFERRED ELECTRIC PREFERRED ELECTRIC PREFERRED ELECTRIC	ROTARY LIGHT REPAIR DIMMER LIGHT REPAIR RELOCATE ELECTRICAL-CITY HALL	SIDEWALKS MAINTENANCE PARK & RECREATION FAC PARK & RECREATION FAC CITY CLERK	9,362.75 201.28 233.92 1,724.48
103071	PUD	ACCT #2023-4068-3	PARK & RECREATION FAC	8.03
	PUD	ACCT #2051-3624-5	SEWER LIFT STATION	14.70
	PUD	ACCT #2024-6103-4	UTIL ADMIN	15.30
	PUD	ACCT #2020-3113-4	PUMPING PLANT	16.22
	PUD	ACCT #2024-9948-9	COMMUNITY EVENTS	20.74
	PUD	ACCT #2016-6804-3	PARK & RECREATION FAC	21.71
	PUD	ACCT #2021-7815-8	SEWER LIFT STATION	25.14
	PUD	ACCT #2024-7643-8	SEWER LIFT STATION	25.40
	PUD	ACCT #2016-1018-5	TRANSPORTATION MANAGEM	28.40
	PUD	ACCT #2023-7865-9	MAINT OF GENL PLANT	33.20
	PUD	ACCT #2023-6853-6	TRANSPORTATION MANAGEM	39.05
	PUD	ACCT #2026-9433-7	TRANSPORTATION MANAGEM	39.31
	PUD	ACCT #2021-4048-9	TRANSPORTATION MANAGEM	40.11
	PUD	ACCT #2035-6975-1	STORM DRAINAGE	40.15
	PUD	ACCT #2016-7213-6	SEWER LIFT STATION	42.18
	PUD	ACCT #2016-7089-0	TRANSPORTATION MANAGEM	43.71
	PUD	ACCT #2035-1961-6	NON-DEPARTMENTAL	51.63
	PUD	ACCT #2021-0219-0	TRANSPORTATION MANAGEM	52.60
	PUD	ACCT #2007-9006-1	PARK & RECREATION FAC	57.34
	PUD	ACCT #2006-2538-2	SEWER LIFT STATION	63.83
	PUD	ACCT #2005-7184-2	TRANSPORTATION MANAGEM	65.71
	PUD	ACCT #2006-5074-5	TRANSPORTATION MANAGEM	69.38
	PUD	ACCT #2027-2901-8	TRANSPORTATION MANAGEM	74.93
	PUD	ACCT #2023-6855-1	PARK & RECREATION FAC	78.18
	PUD	ACCT #2000-8403-6	TRANSPORTATION MANAGEM	81.02
	PUD	ACCT #2030-0516-0	STREET LIGHTING	84.59
	PUD	ACCT #2012-2506-7	PARK & RECREATION FAC	87.13
	PUD	ACCT #2020-0032-9	PARK & RECREATION FAC	90.40
	PUD	ACCT #2020-1258-9	PARK & RECREATION FAC	95.79
	PUD	ACCT #2023-6854-4	TRANSPORTATION MANAGEM	107.66
	PUD	ACCT #2008-2727-7	TRANSPORTATION MANAGEM	113.38
	PUD	ACCT #2021-4311-1	TRANSPORTATION MANAGEM	117.43
	PUD	ACCT #2025-5745-0	STREET LIGHTING	130.53
	PUD	ACCT #2024-6354-3	SEWER LIFT STATION	164.58
	PUD	ACCT #2032-2345-8	PARK & RECREATION FAC	175.42
	PUD	ACCT #2004-7954-1	COMMUNITY CENTER	207.81
	PUD	ACCT #2032-3100-6	TRANSPORTATION MANAGEM	225.20
	PUD	ACCT #2000-7044-9	TRANSPORTATION MANAGEM	285.15
	PUD	ACCT #2023-0972-0	TRAFFIC CONTROL DEVICES	290.69
	PUD	ACCT #2010-2169-8	PARK & RECREATION FAC	323.54
	PUD	ACCT #2010-6528-1	PARK & RECREATION FAC	436.82
	PUD	ACCT #2002-2385-7	PARK & RECREATION FAC	493.41
	PUD	ACCT #2010-2160-7	PARK & RECREATION FAC	573.88
	PUD	ACCT #2005-8648-5	SEWER LIFT STATION	1,096.14
	PUD	ACCT #2008-2454-8	MAINT OF GENL PLANT	1,408.83
	PUD	ACCT #2003-0347-7	WATER FILTRATION PLANT	2,477.65
	PUD	ACCT #2011-4725-3	PUMPING PLANT	2,589.35
	PUD	ACCT #2014-6303-1	PUBLIC SAFETY BLDG.	3,533.71
	PUD	ACCT #2015-7792-1	PUMPING PLANT	4,739.34
	PUD	ACCT #2020-7500-8	WASTE WATER TREATMENT F	6,312.51
	PUD	ACCT #2014-2063-5	WASTE WATER TREATMENT F	7,243.30
	PUD	ACCT #2017-2118-0	WASTE WATER TREATMENT F	20,763.69
103072	PUGET SOUND SECURITY PUGET SOUND SECURITY	KEYS MADE	EQUIPMENT RENTAL EQUIPMENT RENTAL	21.87 21.87

DATE: 9/30/2015
TIME: 10:48:24AM

**CITY OF MARYSVILLE
INVOICE LIST**

PAGE: 8

FOR INVOICES FROM 9/24/2015 TO 9/30/2015

<u>CHK #</u>	<u>VENDOR</u>	<u>ITEM DESCRIPTION</u>	<u>ACCOUNT DESCRIPTION</u>	<u>ITEM AMOUNT</u>
103072	PUGET SOUND SECURITY	KEYS MADE	EQUIPMENT RENTAL	21.87
	PUGET SOUND SECURITY	LOCK SETS AND KEYS	ROADWAY MAINTENANCE	69.84
103073	PUGET SOUND SECURITY	SECURITY SERVICES	PROBATION	753.38
	PUGET SOUND SECURITY		MUNICIPAL COURTS	2,260.12
103074	PUMPTECH INC	SUBMERSIBLE PUMP	SEWER CAPITAL PROJECTS	12,653.44
	PUMPTECH INC		SEWER CAPITAL PROJECTS	12,653.44
103075	RANDHAWA, MOHINDER	INTERPRETER SERVICES	COURTS	108.43
	RANDHAWA, MOHINDER		COURTS	150.00
	RANDHAWA, MOHINDER		COURTS	150.00
103076	RH2 ENGINEERING INC	PROFESSIONAL SERVICES	UTIL ADMIN	2,886.34
103077	ROCKHURST UNIV	TRAINING-SCHOOLCRAFT	UTIL ADMIN	299.00
103078	ROTH, JERAMIE	REIMBURSE MEAL	PARK & RECREATION FAC	14.00
103079	ROYCE, KEITH	UB 849000644000 7620 65TH DR N	WATER/SEWER OPERATION	212.30
103080	SASE COMPANY INC	CUTTER AND FRONT WHEELS	ROADWAY MAINTENANCE	629.70
103081	SEA-ALASKA INDUSTRIA	REBUILD AERATOR	WASTE WATER TREATMENT F	589.70
	SEA-ALASKA INDUSTRIA	REBUILD MOTOR	WASTE WATER TREATMENT F	613.63
	SEA-ALASKA INDUSTRIA	REBUILD AERATOR	WASTE WATER TREATMENT F	2,611.20
103082	SHERWIN WILLIAMS	PAINT AND SUPPLIES	MAINT OF GENL PLANT	73.72
103083	SHRED-IT US	MONTHLY SHREDDING SERVICE	PROBATION	16.79
	SHRED-IT US		MUNICIPAL COURTS	50.38
	SHRED-IT US		POLICE INVESTIGATION	57.25
	SHRED-IT US		DETENTION & CORRECTION	57.25
	SHRED-IT US		OFFICE OPERATIONS	57.25
	SHRED-IT US		POLICE PATROL	57.32
103084	SKAGIT PLUMBING	RESTROOM REPAIR	PUBLIC SAFETY BLDG.	163.20
103085	SMARSH INC	MOBILE TEXT	COMPUTER SERVICES	27.00
103086	SMOKEY POINT CONCRET	DRAIN ROCK	SOURCE OF SUPPLY	246.54
	SMOKEY POINT CONCRET	PITRUNS	SOURCE OF SUPPLY	416.31
	SMOKEY POINT CONCRET	DRAIN ROCK	SOURCE OF SUPPLY	1,027.32
103087	SNAP-ON INCORPORATED	CHARGERS, LIGHTS, HOSE CUTTER	EQUIPMENT RENTAL	242.48
	SNAP-ON INCORPORATED	TAPS, RATCHET AND GAUGE SET	EQUIPMENT RENTAL	300.21
103088	SNO CO FINANCE	VEHICLE REPAIRS	EQUIPMENT RENTAL	9,362.02
103089	SNO CO PUBLIC WORKS	SOLID WASTE CHARGES	SOLID WASTE OPERATIONS	137,531.00
103090	SNO CO TREASURER	INMATE HOUSING-AUGUST 2015	DETENTION & CORRECTION	13,113.58
103091	SOUND PUBLISHING	LEGAL AD	CITY CLERK	149.91
103092	SOUND PUBLISHING		SEWER CAPITAL PROJECTS	184.80
103093	SOUND PUBLISHING		COMMUNITY DEVELOPMENT-	306.49
103094	SOUND SAFETY	BLOODBORNE KITS	ER&R	75.81
	SOUND SAFETY	SAFETY VESTS AND MESH PANTS	GENERAL SERVICES - OVERH	87.48
	SOUND SAFETY	HEARING PROTECTION AND OVERALL	ER&R	190.25
	SOUND SAFETY	JEANS AND BOOTS-ROCHE	COMMUNITY DEVELOPMENT-	228.60
	SOUND SAFETY	GLOVES	DETENTION & CORRECTION	251.71
	SOUND SAFETY		ER&R	339.46
	SOUND SAFETY	TSHIRTS	ER&R	340.65
	SOUND SAFETY	SAFETY SHIRTS	ER&R	422.25
103095	SOUTHERN COMPUTER	PRINTER	POLICE PATROL	115.15
	SOUTHERN COMPUTER		OFFICE OPERATIONS	115.15
	SOUTHERN COMPUTER	ONLINE UPS FOR LAB PC	WASTE WATER TREATMENT F	749.02
	SOUTHERN COMPUTER	BATTERIES	SOURCE OF SUPPLY	805.98
	SOUTHERN COMPUTER	SCANNERS	TRIBAL GAMING-GENL	1,768.00
103096	SPRINGBROOK NURSERY	GRAVEL	PARK & RECREATION FAC	115.77
	SPRINGBROOK NURSERY	BARK	STORM DRAINAGE	371.57
103097	STAPLES	OFFICE SUPPLIES	PARK & RECREATION FAC	17.34
	STAPLES		OPERA HOUSE	28.27
	STAPLES		ENGR-GENL	40.73
	STAPLES		PARK & RECREATION FAC	58.21
	STAPLES		PARK & RECREATION FAC	76.23
	STAPLES		COMMUNITY DEVELOPMENT-	111.85
	STAPLES		PARK & RECREATION FAC	113.99
	STAPLES		COMMUNITY DEVELOPMENT-	207.01
	STAPLES		OPERA HOUSE	230.74

DATE: 9/30/2015
TIME: 10:48:24AM

**CITY OF MARYSVILLE
INVOICE LIST**

PAGE: 9

FOR INVOICES FROM 9/24/2015 TO 9/30/2015

<u>CHK #</u>	<u>VENDOR</u>	<u>ITEM DESCRIPTION</u>	<u>ACCOUNT DESCRIPTION</u>	<u>ITEM AMOUNT</u>
103097	STAPLES	OFFICE SUPPLIES	MUNICIPAL COURTS	381.48
	STAPLES		MUNICIPAL COURTS	400.36
	STAPLES		UTILITY BILLING	465.27
103098	STATE PATROL	FINGERPRINT ID SERVICES	GENERAL FUND	377.25
	STATE PATROL	ACCESS USER FEE	OFFICE OPERATIONS	534.00
103099	SUMMIT LAW GROUP	GENERAL LABOR	PERSONNEL ADMINISTRATIOI	1,871.00
103100	SUPPLYWORKS	JANITORIAL SUPPLIES	MAINT OF GENL PLANT	250.35
	SUPPLYWORKS		ADMIN FACILITIES	304.72
	SUPPLYWORKS		PUBLIC SAFETY BLDG.	330.59
	SUPPLYWORKS		UTIL ADMIN	349.59
	SUPPLYWORKS		COURT FACILITIES	398.55
103101	TACOMA SCREW PRODUCT	HARDWARE	EQUIPMENT RENTAL	109.78
103102	TCA ARCHITECTURE PLA	PROFESSIONAL SERVICES	SEWER CAPITAL PROJECTS	1,222.00
103103	THOMAS, MARK	REIMBURSE TRAVEL EXPENSE	POLICE PATROL	187.52
103104	TILLMAN, DIANE	REFUND CLASS FEES	PARKS-RECREATION	25.00
103105	TRAFFIC SAFETY SUPPL	SIGN BRACKETS	TRANSPORTATION MANAGEM	1,603.50
103106	TRANSPORTATION, DEPT	PROJECT COSTS	GMA - STREET	4,066.00
103107	TYLER TECHNOLOGIES	LICENSING SUPPORT	COMPUTER SERVICES	66,496.87
103108	UNDERWOOD, CAROL	RENTAL DEPOSIT REFUND	GENERAL FUND	100.00
103109	UNITED PARCEL SERVIC	SHIPPING EXPENSE	SEWER LIFT STATION	26.77
103110	USA BLUEBOOK	GASKETS AND CHART PENS	HYDRANTS	128.14
103111	UTILITIES UNDERGROUN	EXCAVATION NOTICES	UTILITY LOCATING	457.38
103112	VERIZON	PHONE CHARGES	PURCHASING/CENTRAL STOF	19.10
	VERIZON		UTILITY BILLING	38.20
	VERIZON		CRIME PREVENTION	40.44
	VERIZON		ANIMAL CONTROL	54.99
	VERIZON		PERSONNEL ADMINISTRATIOI	54.99
	VERIZON		MUNICIPAL COURTS	74.09
	VERIZON		OFFICE OPERATIONS	85.36
	VERIZON		FINANCE-GENL	109.98
	VERIZON		PROPERTY TASK FORCE	109.98
	VERIZON		FACILITY MAINTENANCE	109.98
	VERIZON		EQUIPMENT RENTAL	112.29
	VERIZON		LEGAL-GENL	149.99
	VERIZON		RECREATION SERVICES	150.49
	VERIZON		EXECUTIVE ADMIN	164.97
	VERIZON		YOUTH SERVICES	164.97
	VERIZON		LEGAL - PROSECUTION	165.01
	VERIZON		DETENTION & CORRECTION	168.48
	VERIZON		PARK & RECREATION FAC	173.00
	VERIZON		ENGR-GENL	186.38
	VERIZON		WATER SUPPLY MAINS	220.74
	VERIZON		SOLID WASTE CUSTOMER EX	268.48
	VERIZON		COMMUNITY DEVELOPMENT-	274.55
	VERIZON		WASTE WATER TREATMENT F	369.59
	VERIZON		GENERAL SERVICES - OVERF	414.52
	VERIZON		POLICE INVESTIGATION	416.27
	VERIZON		STORM DRAINAGE	437.80
	VERIZON		COMPUTER SERVICES	495.91
	VERIZON		SOLID WASTE CUSTOMER EX	555.52
	VERIZON		POLICE ADMINISTRATION	702.20
	VERIZON		UTIL ADMIN	1,514.84
	VERIZON		SOLID WASTE OPERATIONS	1,938.50
	VERIZON		POLICE PATROL	4,402.73
103113	WAGWORKS	FLEX PLAN FEES	PERSONNEL ADMINISTRATIOI	57.00
103114	WASHINGTON STATE UNV	PESTICIDE RECERT-GEIST	UTIL ADMIN	120.00
	WASHINGTON STATE UNV	PESTICIDE RECERT-KEEFE	UTIL ADMIN	120.00
	WASHINGTON STATE UNV	PESTICIDE RECERT-MILLER	UTIL ADMIN	120.00
	WASHINGTON STATE UNV	PESTICIDE RECERT-WINELAND	UTIL ADMIN	120.00
103115	WAXIE SANITARY SUPPL	JANITORIAL SUPPLIES	PARK & RECREATION FAC	471.71
103116	WEST PAYMENT CENTER	WEST INFORMATION CHARGES	POLICE INVESTIGATION	234.03

DATE: 9/30/2015
 TIME: 10:48:24AM

**CITY OF MARYSVILLE
 INVOICE LIST**

PAGE: 10

FOR INVOICES FROM 9/24/2015 TO 9/30/2015

<u>CHK #</u>	<u>VENDOR</u>	<u>ITEM DESCRIPTION</u>	<u>ACCOUNT DESCRIPTION</u>	<u>ITEM AMOUNT</u>
103116	WEST PAYMENT CENTER	WEST INFORMATION CHARGES	LEGAL - PROSECUTION	704.26
103117	WIDE FORMAT COMPANY	MAINTENANCE AGREEMENT-KIP PRIN	UTIL ADMIN	106.62
103118	WOODS, KYLE	REIMBURSE TOTES & GLOVE PURCHA	ENGR-GENL	67.39
103119	ZOHO CORPORATION	LOG SERVER AND MAINTENANCE	INFORMATION SERVICES	-209.97
	ZOHO CORPORATION		COMPUTER SERVICES	2,595.97

WARRANT TOTAL: **740,001.39**

REASON FOR VOIDS:
 UNCLAIMED PROPERTY
 INITIATOR ERROR
 WRONG VENDOR
 CHECK LOST/DAMAGED IN MAIL

Index #4

CITY OF MARYSVILLE
EXECUTIVE SUMMARY FOR ACTION

CITY COUNCIL MEETING DATE: October 12, 2015

AGENDA ITEM: Payroll	AGENDA SECTION:	
PREPARED BY: Sandy Langdon, Finance Director	AGENDA NUMBER:	
ATTACHMENTS: Blanket Certification	APPROVED BY:	
	MAYOR	CAO
BUDGET CODE:	AMOUNT:	

RECOMMENDED ACTION:

The Finance and Executive Departments recommend City Council approve the September 18, 2015 payroll in the amount \$1,065,360.05 Check No.'s 29273 through 29306.

COUNCIL ACTION:

Index #6

CITY OF MARYSVILLE AGENDA BILL
EXECUTIVE SUMMARY FOR ACTION

CITY COUNCIL MEETING DATE: 10/12/2015

AGENDA ITEM: Professional Services Agreement with MWH Americas, Inc. for Engineering Services	
PREPARED BY: Karen Latimer, Public Works Operations Manager	DIRECTOR APPROVAL:
DEPARTMENT: Public Works	
ATTACHMENTS: 1. Professional Services Agreement	
BUDGET CODE: 40220594.563000 W1502	AMOUNT: \$40,850.00
SUMMARY:	

This Professional Services Agreement will provide the City with engineering design and construction management and inspection services for repair or replacement of the Cedarcrest Reservoir roof. MWH Americas, Inc. will perform the following services:

- Project management
- Basis of design
- Final design
- Bidding assistance
- Construction management assistance

RECOMMENDED ACTION:

Staff recommends that Council Authorize the Mayor to sign and execute a Professional Services Agreement between the City of Marysville and MWH Americas, Inc. in the amount of \$40,850.

**PROFESSIONAL SERVICES AGREEMENT BETWEEN
CITY OF MARYSVILLE
AND MWH AMERICAS, INC.
FOR CONSULTANT SERVICES**

THIS AGREEMENT ("Agreement") is made and entered into by and between the City of Marysville, a Washington State municipal corporation ("City"), and MWH Americas, Inc., a California Corporation ("Consultant").

NOW, THEREFORE, in consideration of the terms, conditions, covenants and performances contained herein, the parties hereto agree as follows:

ARTICLE I. PURPOSE

The purpose of this Agreement is to provide the City with consultant services to design modifications to the Cedarcrest Reservoir roof and to provide bidding and construction support services as described in Article II. The general terms and conditions of the relationship between the City and the Consultant are specified in this Agreement.

ARTICLE II. SCOPE OF SERVICES

The Scope of Services is attached hereto as **Exhibit "A"** and incorporated herein by this reference ("Scope of Services"). All services and materials necessary to accomplish the tasks outlined in the Scope of Services shall be provided by the Consultant unless noted otherwise in the Scope of Services or this Agreement. All such services shall be provided in accordance with the standards of the Consultant's profession.

ARTICLE III. OBLIGATIONS OF THE CONSULTANT

III.1 MINOR CHANGES IN SCOPE. The Consultant shall accept minor changes, amendments, or revision in the detail of the Scope of Services as may be required by the City when such changes will not have any impact on the service costs or proposed delivery schedule. Extra work, if any, involving substantial changes and/or changes in cost or schedules will be addressed as follows:

Extra Work. The City may desire to have the Consultant perform work or render services in connection with each project in addition to or other than work provided for by the expressed intent of the Scope of Services in the scope of services. Such work will be considered as extra work and will be specified in a written supplement to the scope of services, to be signed by both parties, which will set forth the nature and the scope thereof. All proposals for extra work or services shall be prepared by the Consultant at no cost to the City. Work under a supplemental agreement shall not proceed until executed

in writing by the parties.

III.2 WORK PRODUCT AND DOCUMENTS. The work product and all documents produced under this Agreement shall be furnished by the Consultant to the City, and upon completion of the work shall become the property of the City, except that the Consultant may retain one copy of the work product and documents for its records. The Consultant will be responsible for the accuracy of the work, even though the work has been accepted by the City.

In the event that the Consultant shall default on this Agreement or in the event that this Agreement shall be terminated prior to its completion as herein provided, all work product of the Consultant, along with a summary of work as of the date of default or termination, shall become the property of the City. Upon request, the Consultant shall tender the work product and summary to the City. Tender of said work product shall be a prerequisite to final payment under this Agreement. The summary of work done shall be prepared at no additional cost to the City.

Consultant will not be held liable for reuse of documents produced under this Agreement or modifications thereof for any purpose other than those authorized under this Agreement without the written authorization of Consultant.

III.3 TERM. The term of this Agreement shall commence on October 12, 2015 and shall terminate at midnight, November 30, 2016. The parties may extend the term of this Agreement by written mutual agreement.

III.4 NONASSIGNABLE. The services to be provided by the Consultant shall not be assigned or subcontracted without the express written consent of the City.

III.5 EMPLOYMENT.

a. The term "employee" or "employees" as used herein shall mean any officers, agents, or employee of the of the Consultant.

b. Any and all employees of the Consultant, while engaged in the performance of any work or services required by the Consultant under this Agreement, shall be considered employees of the Consultant only and not of the City, and any and all claims that may or might arise under the Workman's Compensation Act on behalf of any said employees while so engaged, and any and all claims made by any third party as a consequence of any negligent act or omission on the part of the Consultant or its employees while so engaged in any of the work or services provided herein shall be the sole obligation of the Consultant.

c. Consultant represents, unless otherwise indicated below, that all employees of Consultant that will provide any of the work under this Agreement have not ever been retired from a Washington State retirement system, including but not limited to Teacher (TRS), School District (SERS), Public Employee (PERS), Public Safety (PSERS), law enforcement and fire fighters (LEOFF), Washington State Patrol

(WSPRS), Judicial Retirement System (JRS), or otherwise. *(Please indicate No or Yes below)*

_____ No employees supplying work have ever been retired from a Washington state retirement system.

_____ Yes employees supplying work have been retired from a Washington state retirement system.

In the event the Consultant indicates “no”, but an employee in fact was a retiree of a Washington State retirement system, and because of the misrepresentation the City is required to defend a claim by the Washington State retirement system, or to make contributions for or on account of the employee, or reimbursement to the Washington State retirement system for benefits paid, Consultant hereby agrees to save, indemnify, defend and hold City harmless from and against all expenses and costs, including reasonable attorney’s fees incurred in defending the claim of the Washington State retirement system and from all contributions paid or required to be paid, and for all reimbursement required to the Washington State retirement system. In the event Consultant affirms that an employee providing work has ever retired from a Washington State retirement system, said employee shall be identified by Consultant, and such retirees shall provide City with all information required by City to report the employment with Consultant to the Department of Retirement Services of the State of Washington.

III.6 INDEMNITY.

a. **Indemnification / Hold Harmless.** Consultant shall defend, indemnify and hold the City, its officers, officials, employees and volunteers harmless from any and all claims, injuries, damages, losses or suits including attorney fees, arising out of or resulting from the acts, errors or omissions of the Consultant in performance of this Agreement, except for injuries and damages caused by the sole negligence of the City.

b. Should a court of competent jurisdiction determine that this Agreement is subject to RCW 4.24.115, then, in the event of liability for damages arising out of bodily injury to persons or damages to property caused by or resulting from the concurrent negligence of the Consultant and the City, its officers, officials, employees, and volunteers, the Consultant's liability, including the duty and cost to defend, hereunder shall be only to the extent of the Consultant's negligence.

c. The provisions of this section shall survive the expiration or termination of this agreement.

d. For the purposes of the indemnity contained in subpart “A” of this paragraph 3.6, Consultant hereby knowing, intentionally, and voluntarily waives the immunity of the Industrial Insurance Act, Title 51 RCW, solely for the purposes of this indemnification. This waiver has been mutually negotiated by the parties.

_____(initials) _____(initials)

III.7 INSURANCE.

a. **Minimum Limits of Insurance.** The Consultant shall procure, and maintain for the duration of the Agreement, insurance against claims for injuries to persons or damage to property which may arise from or in connection with the performance of the work and services hereunder by the Consultant, its agents, representatives, employees or subcontractors. The Consultant shall, before commencing work under this agreement, file with the City certificates of insurance coverage and the policy endorsement to be kept in force continuously during this Agreement, in a form acceptable to the City. Said certificates and policy endorsement shall name the City, its officers, elected officials, agents and/or employees as an additional named insured with respect to all coverages except professional liability insurance and workers' compensation.

b. **Minimum Scope of Insurance - Consultant shall obtain insurance of the types described below:**

- (1). Automobile Liability insurance covering all owned, non-owned, hired and leased vehicles. Coverage shall be written on Insurance Services Office (ISO) form CA 00 01 or a substitute form providing equivalent liability coverage. If necessary, the policy shall be endorsed to provide contractual liability coverage.
- (2). Commercial General Liability insurance shall be written on ISO occurrence form CG 00 01 and shall cover liability arising from premises, operations, independent contractors and personal injury and advertising injury. The City shall be named as an insured under the Consultant's Commercial General Liability insurance policy with respect to the work performed for the City.
- (3). Workers' Compensation coverage as required by the Industrial Insurance laws of the State of Washington.
- (4). Professional Liability insurance appropriate to the Consultant's profession.

c. **The minimum insurance limits shall be as follows:**

- (1) Comprehensive General Liability. \$1,000,000 combined single limit per occurrence for bodily injury personal injury and property damage; \$2,000,000 general aggregate.

(2) Automobile Liability. \$1,000,000 combined single limit per accident for bodily injury and property damage.

(3) Workers' Compensation. Workers' compensation limits as required by the Workers' Compensation Act of Washington.

(4) Professional Liability/Consultant's Errors and Omissions Liability. \$1,000,000 per claim and \$1,000,000 as an annual aggregate.

d. **Notice of Cancellation**. In the event that the Consultant receives notice (written, electronic or otherwise) that any of the above required insurance coverage is being cancelled and/or terminated, the Consultant shall immediately (within forty-eight (48) hours) provide written notification of such cancellation/termination to the City.

e. **Acceptability of Insurers**. Insurance to be provided by Consultant shall be with a current A.M.Bests rating of no less than A:VII, or if not rated by Bests, with minimum surpluses the equivalent of Bests' VII rating.

f. **Verification of Coverage**. In signing this agreement, the Consultant is acknowledging and representing that required insurance is active and current. Consultant shall furnish the City with original certificates and a copy of the amendatory endorsements, including but not necessarily limited to the additional insured endorsement, evidencing the insurance requirements of the Consultant before commencement of the work. Further, throughout the term of this Agreement, the Consultant shall provide the City with proof of insurance upon request by the City.

g. **Insurance shall be Primary**. The Consultant's insurance coverage shall be primary insurance as respect the City. Any insurance, self-insurance, or insurance pool coverage maintained by the City shall be excess of the Consultant's insurance and shall not contribute with it.

h. **No Limitation**. Consultant's maintenance of insurance as required by this Agreement shall not be construed to limit the liability of the Consultant to the coverage provided by such insurance or otherwise limit the recourse to any remedy available at law or in equity.

i. **Claims-made Basis**. Unless approved by the City all insurance policies shall be written on an "Occurrence" policy as opposed to a "Claims-made" policy. The City may require an extended reporting endorsement on any approved "Claims-made" policy.

j. **Failure to Maintain Insurance** Failure on the part of the Consultant to maintain the insurance as required shall constitute a material breach of contract, upon which the City may, after giving five business days' notice to the Consultant to correct the breach, immediately terminate the contract or, at its discretion, procure or renew such

insurance and pay any and all premiums in connection therewith, with any sums so expended to be repaid to the City on demand, or at the sole discretion of the City, offset against funds due the Consultant from the City.

III.8 DISCRIMINATION PROHIBITED AND COMPLIANCE WITH EQUAL OPPORTUNITY LEGISLATION. The Consultant agrees to comply with equal opportunity employment and not to discriminate against client, employee, or applicant for employment or for services because of race, creed, color, religion, national origin, marital status, sex, sexual orientation, age or handicap except for a bona fide occupational qualification with regard, but not limited to, the following: employment upgrading; demotion or transfer; recruitment or any recruitment advertising; layoff or terminations; rates of pay or other forms of compensation; selection for training, rendition of services. The Consultant further agrees to maintain (as appropriate) notices, posted in conspicuous places, setting forth the provisions of this nondiscrimination clause. The Consultant understands and agrees that if it violates this nondiscrimination provision, this Agreement may be terminated by the City, and further that the Consultant will be barred from performing any services for the City now or in the future, unless a showing is made satisfactory to the City that discriminatory practices have been terminated and that recurrence of such action is unlikely.

III.9 UNFAIR EMPLOYMENT PRACTICES. During the performance of this Agreement, the Consultant agrees to comply with RCW 49.60.180, prohibiting unfair employment practices.

III.10 LEGAL RELATIONS. The Consultant shall comply with all federal, state and local laws and ordinances applicable to work to be done under this Agreement. The Consultant represents that the firm and all employees assigned to work on any City project are in full compliance with the statutes of the State of Washington governing activities to be performed and that all personnel to be assigned to the work required under this Agreement are fully qualified and properly licensed to perform the work to which they will be assigned. This Agreement shall be interpreted and construed in accordance with the laws of Washington. Venue for any litigation commenced relating to this Agreement shall be in Snohomish County Superior Court.

III.11 INDEPENDENT CONTRACTOR.

a. The Consultant and the City understand and expressly agree that the Consultant is an independent contractor in the performance of each and every part of this Agreement. The Consultant expressly represents, warrants and agrees that his status as an independent contractor in the performance of the work and services required under this Agreement is consistent with and meets the six-part independent contractor test set forth in RCW 51.08.195 or as hereafter amended. The Consultant, as an independent contractor, assumes the entire responsibility for carrying out and accomplishing the services required under this Agreement. The Consultant shall make no claim of City employment nor shall claim any related employment benefits, social security, and/or retirement benefits.

b. The Consultant shall be solely responsible for paying all taxes, deductions, and assessments, including but not limited to federal income tax, FICA, social security tax, assessments for unemployment and industrial injury, and other deductions from income which may be required by law or assessed against either party as a result of this Agreement. In the event the City is assessed a tax or assessment as a result of this Agreement, the Consultant shall pay the same before it becomes due.

c. The City may, during the term of this Agreement, engage other independent contractors to perform the same or similar work that the Consultant performs hereunder.

d. Prior to commencement of work, the Consultant shall obtain a business license from the City.

III.12 CONFLICTS OF INTEREST. The Consultant agrees to and shall notify the City of any potential conflicts of interest in Consultant’s client base and shall obtain written permission from the City prior to providing services to third parties where a conflict or potential conflict of interest is apparent. If the City determines in its sole discretion that a conflict is irreconcilable, the City reserves the right to terminate this Agreement.

III.13 CITY CONFIDENCES. The Consultant agrees to and will keep in strict confidence, and will not disclose, communicate or advertise to third parties without specific prior written consent from the City in each instance, the confidences of the City or any information regarding the City or services provided to the City.

III.14 SUBCONTRACTORS/SUBCONSULTANTS.

a. The Consultant shall is responsible for all work performed by subcontractors/subconsultants pursuant to the terms of this Agreement.

b. The Consultant must verify that any subcontractors/subconsultants they directly hire meet the responsibility criteria for the project. Verification that a subcontractor/subconsultant has proper license and bonding, if required by statute, must be included in the verification process. The Consultant will use the following Subcontractors/Subconsultants or as set forth in Exhibit ____:

c. The Consultant may not substitute or add subcontractors/subconsultants without the written approval of the City.

d. All Subcontractors/Subconsultants shall have the same insurance coverages and limits as set forth in this Agreement and the Consultant shall provide verification of said insurance coverage.

ARTICLE IV. OBLIGATIONS OF THE CITY

IV.1 PAYMENTS.

a. The Consultant shall be paid by the City for services rendered under this Agreement as described in the Scope of Services and as provided in this section. In no event shall the compensation paid to Consultant under this Agreement exceed \$40,850.00 without the written agreement of the Consultant and the City. Such payment shall be full compensation for work performed and services rendered and for all labor, materials, supplies, equipment and incidentals necessary to complete the work. In the event the City elects to expand the scope of services from that set forth in Exhibit A, the City shall pay Consultant a mutually agreed amount.

b. The Consultant shall submit a monthly invoice to the City for services performed in the previous calendar month in a format acceptable to the Cities. The Consultant shall maintain time and expense records and provide them to the Cities upon request.

c. The City will pay timely submitted and approved invoices received before the 20th of each month within thirty (30) days of receipt.

IV.2 CITY APPROVAL. Notwithstanding the Consultant's status as an independent contractor, results of the work performed pursuant to this Agreement must meet the approval of the City, which shall not be unreasonably withheld if work has been completed in compliance with the Scope of Services and City requirements.

IV.3 MAINTENANCE/INSPECTION OF RECORDS. The Consultant shall maintain all books, records, documents and other evidence pertaining to the costs and expenses allowable under this Agreement in accordance with generally accepted accounting practices. All such books and records required to be maintained by this Agreement shall be subject to inspection and audit by representatives of the City and/or the Washington State Auditor at all reasonable times, and the Consultant shall afford the proper facilities for such inspection and audit. Representatives of the City and/or the Washington State Auditor may copy such books, accounts and records where necessary to conduct or document an audit. The Consultant shall preserve and make available all such books of account and records for a period of three (3) years after final payment under this Agreement. In the event that any audit or inspection identifies any discrepancy in such financial records, the Consultant shall provide the City with appropriate clarification and/or financial adjustments within thirty (30) calendar days of notification of the discrepancy.

ARTICLE V. GENERAL

V.1 NOTICES. Notices to the City shall be sent to the following address:

Karen Latimer
Public Works Operations Manager
City of Marysville
Department of Public Works
80 Columbia Avenue
Marysville, WA 98270

Notices to the Consultant shall be sent to the following address:

Gregory Harris, P.E., PMP
MWH Americas, Inc.
2353 130th Avenue NE
Suite 200
Bellevue, WA 98005

Receipt of any notice shall be deemed effective three (3) days after deposit of written notice in the U.S. mail with proper postage and address.

V.2 TERMINATION. The right is reserved by the City to terminate this Agreement in whole or in part at any time upon ten (10) calendar days' written notice to the Consultant.

If this Agreement is terminated in its entirety by the City for its convenience, the City shall pay the Consultant for satisfactory services performed through the date of termination in accordance with payment provisions of Section VI.1.

V.3 DISPUTES. The parties agree that, following reasonable attempts at negotiation and compromise, any unresolved dispute arising under this Agreement may be resolved by a mutually agreed-upon alternative dispute resolution of arbitration or mediation.

V.4 EXTENT OF AGREEMENT/MODIFICATION. This Agreement, together with attachments or addenda, represents the entire and integrated Agreement between the parties and supersedes all prior negotiations, representations, or agreements, either written or oral. This Agreement may be amended, modified or added to only by written instrument properly signed by both parties.

V.5 SEVERABILITY

a. If a court of competent jurisdiction holds any part, term or provision of this Agreement to be illegal or invalid, in whole or in part, the validity of the remaining provisions shall not be affected, and the parties' rights and obligations shall be construed and enforced as if the Agreement did not contain the particular provision held to be invalid.

b. If any provision of this Agreement is in direct conflict with any statutory provision of the State of Washington, that provision which may conflict shall be deemed

inoperative and null and void insofar as it may conflict, and shall be deemed modified to conform to such statutory provision.

V.6 **NONWAIVER.** A waiver by either party hereto of a breach by the other party hereto of any covenant or condition of this Agreement shall not impair the right of the party not in default to avail itself of any subsequent breach thereof. Leniency, delay or failure of either party to insist upon strict performance of any agreement, covenant or condition of this Agreement, or to exercise any right herein given in any one or more instances, shall not be construed as a waiver or relinquishment of any such agreement, covenant, condition or right.

V.7 **FAIR MEANING.** The terms of this Agreement shall be given their fair meaning and shall not be construed in favor of or against either party hereto because of authorship. This Agreement shall be deemed to have been drafted by both of the parties.

V.8 **GOVERNING LAW.** This Agreement shall be governed by and construed in accordance with the laws of the State of Washington.

V.9 **VENUE.** The venue for any action to enforce or interpret this Agreement shall lie in the Superior Court of Washington for Snohomish County, Washington.

V.10 **COUNTERPARTS.** This Agreement may be executed in one or more counterparts, each of which shall be deemed an original, but all of which shall constitute one and the same Agreement.

V.11 **AUTHORITY TO BIND PARTIES AND ENTER INTO AGREEMENT.** The undersigned represent that they have full authority to enter into this Agreement and to bind the parties for and on behalf of the legal entities set forth below.

DATED this _____ day of _____, 2015.

CITY OF MARYSVILLE

MWH AMERICAS, INC.

By _____
Jon Nehring, Mayor

By _____
Mark Graham, Washington Area Manager

Approved as to form:

Jon Walker, City Attorney

Exhibit "A"
Scope of Services

**SCOPE OF WORK
PROFESSIONAL SERVICES
FOR THE
CEDARCREST RESERVOIR ROOF PROJECT
TO BE PROVIDED BY
MWH AMERICAS, INC
FOR THE
CITY OF MARYSVILLE**

This scope of work describes the professional services associated with the Cedarcrest Reservoir Roof Project (the Project) to be provided by MWH Americas, Inc. (MWH) for the City of Marysville (the City). The Project consists of two phases, including phase 1 during design and phase 2 during bidding and construction. The following provides a description of the scope of work by phase and task.

PHASE 1 - DESIGN

TASK 1 - PROJECT MANAGEMENT

- 1.1 - Management of the project over a 1.5 month period during design.
- 1.2 - Monitor schedule and budget and make staff assignments to maintain project schedule.
- 1.3 – Prepare two brief monthly status reports and invoices in standard MWH format.

TASK 2 – BASIS OF DESIGN

2.1 –Existing System Design Review & Evaluation

MWH will review existing reservoir and roofing design record drawings (provided by the City) and communicate with DN Tanks regarding the existing roofing design approach. MWH will also conduct a two-hour site visit to evaluate conditions of existing joints, reservoir roofing and drainage. The budget and schedule for this scope of work assume that no structural repair of the reservoir will be required. MWH's Independent roofing consultant will take a small sample of the existing roofing and have it lab tested for hazardous materials (specifically asbestos.)

2.2 – Roofing System Evaluation and Recommendations

MWH will investigate up to three options for roofing systems for the reservoir, ranging from a hot-mop asphalt coating with gravel (existing system) to a reinforced hot-applied water proofing system with protective board that may include an extended warranty.

2.3 – Basis of Design TM

MWH will draft a brief (up to five pages) memorandum (TM) documenting the roofing system options, costs and recommendations for the City to review. MWH will incorporate review comments into a final TM which will serve as the basis of design.

TASK 3 – FINAL DESIGN

Prepare final design documents for the bidding and construction of the work. Final design will consist of the following subtasks:

3.1 - Prepare 90% Contract Documents

3.1.1 - 90% Drawings

The work associated with this project includes preparation of plan, section and detail drawings for the roof repair. The drawings anticipated to be included in the Contract Documents are listed below:

<u>Drawing No.</u>	<u>Description</u>
<u>General</u>	
G-1	Cover and Title Sheet
G-2	Location Map, Vicinity Map, List of Drawings, General Notes
G-3	Abbreviations and Symbols
<u>Mechanical</u>	
GM-1	General Details
M-1	Roof Plan
M-2	Section and Details

Drawings will be prepared using AutoCAD Format. Drawings will be set up in 22" x 34" format and printed to half-scale 11" x 17" size for bidding purposes.

3.1.2 - 90% Specifications

Prepare the technical specifications required for the work, as described below. The City will prepare complete front end documents and bid forms, which MWH will review for coordination with the drawings and specifications. Technical Specifications will be prepared by MWH based on MWH standard specifications in CSI format. Technical specifications will include the following sections:

<u>Section No.</u>	<u>Description</u>
028213	Asbestos Removal (only if necessary)
024119	Demolition and Reconstruction
036000	Grouting

071413	Hot Fluid Applied Waterproofing (or similar if other system is selected)
072216	Roof Insulation (only if selected)
079213	Sealants and Caulking

3.2 – City Review

At the 90 percent level of design completion, a PDF of the Contract Drawings and Specifications will be submitted to the City for review.

3.3 - Final Contract Documents

Review and incorporate comments received from the City into the final Bidding/Contract Documents for the project. Produce final Bidding/Contract Documents and technical specifications in pdf format, suitable for bidding purposes.

PHASE 2 – BIDDING AND CONSTRUCTION

TASK 4 - PROJECT MANAGEMENT

- 4.1 - Management of the project over 2.5 month period during bidding and construction.
- 4.2 - Monitor schedule and budget and make staff assignments to maintain project schedule.
- 4.3 – Prepare two brief monthly status reports and invoices in standard MWH format.

TASK 5 - BIDDING ASSISTANCE

Provide limited assistance (approximately 7 hours) to the City during bidding and award of the project, by responding to bidder's questions. It is assumed that the City will lead the bidding process. The scope for this task is limited to the budget available.

TASK 6 – CONSTRUCTION MANAGEMENT ASSISTANCE

MWH will provide limited (approximately 69 hours) construction management and monitoring of construction services for the City of Marysville. The scope for this task is limited to the budget available. The work includes the following subtasks:

6.1 – Engineering Services

- A. **Shop Drawing Review and Processing.** Receive and log shop drawing submittals provided by the City for review. Return shop drawings to the City upon completion of the review process. Maintain a shop drawing submittal file.
- B. **Clarification of Contract Documents.** Receive and log clarification requests provided by the City for review. Provide response to the City to clarify design details.

6.2 - Field Services:

Provide up to 40 hours of construction inspection, to perform the following services:

- A. **On-Site Field Observation and Monitoring.** Provide part-time on-site field observation and monitoring to observe the quality and progress of the construction to help determine if the provisions of the construction contract documents are being fulfilled, to responsibly carry out the program of inspection to guard the City against defects and deficiencies in the work of the Construction Contractor, and to advise the Construction Contractor when defects and deficiencies are observed in the work.
- B. MWH will direct its efforts toward determining that the completed project will conform to the plans and specifications, but MWH shall not be responsible for the means, methods, techniques, or procedures of construction selected by the Construction Contractor(s) or for the safety precautions and programs incident to the work of Construction Contractor(s) or for any failure of Construction Contractor(s) to comply with laws, ordinances, rules, or regulations applicable to the construction work. The parties recognize that the Construction Contractor(s) is responsible for ensuring that construction is in accordance with the plans and specifications.
- C. Notwithstanding any inferences, references, or statements to the contrary contained within this document, the City understand that MWH would not direct any Construction Contractors, subcontractors, etc., at the job site, and it is hereby agreed that MWH would assume no obligation for any acts, errors, or omissions of parties other than MWH.
- D. **Project Daily Report.** Complete a daily report for the days the inspector is on-site that records decisions and observations of a general or specific nature in chronological order.
- G. **Photographs.** Take initial pre-construction photographs and progress photographs of construction activities on a regular basis to document progress of the work and job site conditions encountered.
- H. **Final Review and Inspection.** Perform a final review and inspection of the construction work and prepare a final list of items to be corrected (i.e. "Punch List"). After substantial completion of the project, verify completion of the punch list.

5.3 - Prepare Record Drawings

- A. Incorporate the Contractor's record information into the CAD design files. Changes in materials, elevations, size and location, from that shown on the

plans shall be shown based on the information provided by the Contractor.
Provide final electronic AutoCAD and pdf files.

SUMMARY OF RESPONSIBILITIES/TASKS OF THE CITY OF MARYSVILLE

The following items are tasks or expenses that are not included within the Consultant's budget and are understood to be accomplished or compensated by the City.

1. City will pay all permit application and review fees.
2. City will provide all legal services related to contract review, protests, claims and related items.
3. City will provide the front end documents and bid forms to include in the Contract Documents.
4. City will lead the bidding and construction management phase services between the Owner and Contractor.

Index #7

CITY OF MARYSVILLE AGENDA BILL
EXECUTIVE SUMMARY FOR ACTION

CITY COUNCIL MEETING DATE: October 12, 2015

AGENDA ITEM: Project Acceptance - Marysville Regional Pond #2	
PREPARED BY: John Cowling	DIRECTOR APPROVAL: 
DEPARTMENT: Public Works - Engineering	
ATTACHMENTS: Notice of Physical Completion	
BUDGET CODE: 40250594.563000. D0401	AMOUNT: N/A
SUMMARY:	

The North Marysville Regional Pond #2 Project involved construction of an approximately 14-acre stormwater pond, a stormwater treatment wetland within the pond, and 1,450 linear feet of a 48-inch RCP conveyance system from the inlet of the pond up to an existing stormwater vault located in 152nd Street NE. This project provides flow control and enhanced water quality treatment for approximately 155 acres of commercial/industrial development. Pond 2 is designed to be hydraulically connected to Pond 1; the two ponds together provide flow control and enhanced water quality treatment for 204.8 acres.

City Council awarded the project to Trimaxx Construction, Inc. on June 09, 2014 in the amount of \$2,506,975.51. The project was completed at a cost of \$2,343,074.19, which was \$163,901.32 or 6.53% below the original bid amount.

Work performed under this contract was inspected by City staff. The work was found to be physically complete in accordance with the approved plans and specifications. Staff recommends Council's acceptance of the project for closeout.

RECOMMENDED ACTION:

Staff recommends that Council authorize the Mayor to accept the Marysville Regional Pond #2 project, starting the 45-day lien filing period for project closeout.



PUBLIC WORKS
Kevin Nielsen, *Director*

80 Columbia Avenue
Marysville, Washington 98270
Phone (360) 363-8100
Fax (360) 363-8284

September 02, 2015

Trimaxx Construction, Inc.
12903 Wayward Way
Sedro Woolley, WA 98284

Subject: Marysville Regional Pond #2 – Notice of Physical Completion

Dear Chris,

In accordance with Section 1-05.11(2) of the Special Provisions, this project was considered physically complete as of May 01, 2015. This notification does not constitute final acceptance. Recommendation for final acceptance will be sent to the City Council for approval at the first available council meeting. Please submit the following items for project closeout:

1. Affidavits of Wages Paid

Upon obtaining receipt of the above items and acceptance I will submit a notice of completion of public works project to obtain the following:

1. Certificate of Release from the Department of Revenue
2. Certificate of Release from the Employment Security Department
3. Certificate of Release from the Department of L&I

It has been a pleasure working with Trimaxx Construction, Inc. on this project. I look forward to working with you on future projects with the City.

Sincerely,

A handwritten signature in blue ink, appearing to read "John A. Cowling", is written over a blue wavy line.

John A. Cowling, PE
Assistant City Engineer

Index #9

CITY OF MARYSVILLE AGENDA BILL

EXECUTIVE SUMMARY FOR ACTION

CITY COUNCIL MEETING DATE: 10/12/2015

AGENDA ITEM: Approve Renewal of SNOCAT Inter-Local	
PREPARED BY: Cmdr. Wendy Wade	DIRECTOR APPROVAL: 
DEPARTMENT: Marysville Police, Investigations	
ATTACHMENTS: See Inter-Local Agreement	
BUDGET CODE: 00108 337 382132	AMOUNT: \$272,033.33
SUMMARY:	

Marysville Police Department requests Council approve the **renewal** of the Inter-local Agreement between Snohomish County and the City of Marysville for Auto Theft Task Force Services. The term of the contract is 07/01/15 – 06/30/2017.

Marysville Police Department as assigned one detective to work with the Auto Theft Task Force (SNOCAT).

Snohomish County will reimburse the City actual expenses for salary and benefits up to a maximum amount of \$134,016.66 per 12 months and overtime up to \$2,000. Per month for 12 months (See Exhibit A) The maximum pay out for the three year period is \$272,033.33.

SNOCAT has been highly effective since it's conception and in 2014 was responsible for over 100 criminal convictions.

RECOMMENDED ACTION: Please approve the renewal of the Inter-Local for the Marysville Detective to continue participating with the SNOCAT, the local regional auto theft task force.

**INTERLOCAL AGREEMENT BETWEEN
SNOHOMISH COUNTY and THE CITY OF MARYSVILLE
FOR AUTO THEFT TASK FORCE SERVICES**

This Interlocal Agreement Between Snohomish County And The City Of Marysville For Auto Theft Task Force Services (the “Agreement”), is entered into by and between Snohomish County, a political subdivision of the State of Washington (hereinafter referred to as the “County”), and the City of Marysville, a municipal corporation of the State of Washington (hereinafter referred to as the “City”).

RECITALS

- A. The Washington State Legislature created the Washington Auto Theft Prevention Authority (hereinafter “WATPA”) for the purpose of preventing and reducing auto theft in the State of Washington.
- B. The County and WATPA entered into an Auto Theft Prevention Grant Contract (hereinafter “Grant Contract”) whereby the County shall use specified grant funds (hereinafter “Grant Funds”) to create and operate a multi-jurisdictional, regional, auto theft task force (hereinafter the “Task Force”); and
- C. Chapter 39.34 RCW permits one or more public agencies to contract with any one or more other public agencies to perform any governmental service, activity, or undertaking that each public agency is authorized by law to perform; and
- D. Several jurisdictions desire to participate as members of the Task Force with Snohomish County administering task force project grants; and
- E. The City desires to enter into an agreement with Snohomish County in order to participate in the Task Force and enable Snohomish County to reimburse the City for such participation; and
- F. The City is authorized to perform each service contemplated herein.

AGREEMENT

NOW THEREFORE, in consideration of the covenants, conditions, performances, and promises contained herein, the parties agree as follows:

1.0 TASK FORCE COMPOSITION, PURPOSE, AND TERM

- 1.1 The City agrees to cooperate in the Task Force, composed of law enforcement, prosecutor, and support personnel, in order to jointly coordinate selected law enforcement activities, resources, and functions to prevent auto theft and to investigate and prosecute auto theft offenders in Snohomish County.
- 1.2 This Agreement shall take effect July 1, 2015, and continue in effect through June 30, 2017, unless earlier terminated or modified as provided in this Agreement.

2.0 ORGANIZATION

- 2.1 The County will be the administrator of this Agreement.
- 2.2 A Snohomish County Sheriff's Office (SCSO) lieutenant will direct all law enforcement personnel assigned to the Task Force, under this Agreement or similarly executed agreements, in their operational duties.
- 2.3 Additional law enforcement personnel may be provided to the Task Force through separate interlocal agreement between the County and other jurisdictions.
- 2.4 Nothing in this Agreement shall restrict the ability of the County or the City to reassign personnel and related equipment and supplies assigned under this Agreement.

3.0 OBLIGATIONS OF CITY

- 3.1 During the term of this Agreement, the City shall employ, dedicate and assign one full-time detective to the Task Force.
- 3.2 The detective's operational assignments will be directed by an SCSO lieutenant assigned to the Task Force.
- 3.3 The detective assigned to the Task Force pursuant to this Agreement shall remain subject to the policies, procedures and directives of the City.

- 3.4 The City agrees to make any certified assurances required by the Grant Contract that are within its particular control, and agrees to make all its records related to the Task Force available for inspection consistent with the Grant Contract and applicable state and federal laws.

4.0 BUDGET AND COMPENSATION

- 4.1 The County, through its Sheriff's Office, shall serve as the fiscal agent and manage Grant Funds, including reimbursement to participating jurisdictions. All revenues collected or generated by or for the Task Force shall be maintained by the County pursuant to law.
- 4.2 The County will reimburse the City actual expenses for salary and benefits up to a maximum amount of \$134,016.66/per 12 months and overtime up to \$2,000/ per 12 months, as detailed in Exhibit A, attached hereto and incorporated herein by this reference.
- 4.3 The City will send quarterly invoices to the County with supporting documentation.
- 4.4 The County will make payments within thirty (30) days from receipt of the quarterly invoice. Invoices shall be sent to Snohomish County Sheriff's Office, Fiscal Division, Mail Stop 606, 3000 Rockefeller Ave., Everett, WA 98201.
- 4.5 Total reimbursement under this contract shall not exceed \$272,033.33.

5.0 GENERAL ADMINISTRATION

- 5.1 The County agrees to provide WATPA with the necessary documentation to receive Grant Funds.
- 5.2 Any factual dispute between the County and the City that relates to this Agreement shall be referred for resolution to the Sheriff, or his/her designee, and the City's Mayor, or his/her designee. In the event the dispute cannot be resolved between the parties to each party's mutual satisfaction, the issue shall be submitted to mediation through the Snohomish County Dispute Resolution Center. Both parties agree to utilize this process prior to the institution of any legal action to enforce the terms and conditions of this agreement. The cost of mediation shall be borne equally by the parties.
- 5.3 The City shall provide the maximum opportunity to Minority and Women Owned Business Enterprises to participate in the performance of this Agreement.

6.0 ASSET FORFEITURE

- 6.1 All potential asset forfeitures initiated or investigated by officers assigned to the Task Force shall be referred to the County for prosecution.
- 6.2 The County shall acquire and dispose of assets seized or forfeited as a result of this Agreement in compliance with law.

7.0 REAL AND PERSONAL PROPERTY

All real or personal property acquired through Grant Funds or activities of the Task Force that are not subject to Section 6 of this Agreement will be held by the County.

8.0 ACQUISITION AND USE OF EQUIPMENT

- 8.1 All equipment purchased with Grant Funds will be held by the County.
- 8.2 Any equipment purchased with Grant Funds will only be used as permitted by the terms of the Grant Contract.
- 8.3 Upon termination of this Agreement, any equipment purchased or otherwise provided by the City will be returned to the City unless otherwise agreed by the parties.
- 8.4 Upon termination of this Agreement, the County will dispose of all acquired equipment in accordance with applicable federal, state and county requirements.

9.0 MODIFICATION

Each party reserves the right to amend this Agreement in the future from time to time as may be mutually agreed upon. No such amendment shall be effective unless written and signed with the same formality as this Agreement.

10.0 NONDISCRIMINATION PROVISION

There shall be no discrimination against any employee who is paid by the grant funds or against any applicant for such employment because of race, color, religion, handicap, marital status, political affiliation, sex, age, or national origin. This provision shall include, but not be limited to the

following: employment, upgrading, demotion, transfer, recruitment, advertising, lay-off or termination, rates of pay or other forms of compensation, and selection for training.

11.0 TERMINATION OF AGREEMENT

Notwithstanding any provisions of this agreement, either party may withdraw from the Agreement by providing written notice of such withdrawal specifying the effective date thereof at least thirty (30) days prior to such date. A withdrawing party may take with it any equipment it has loaned or donated to the Task Force.

12.0 HOLD HARMLESS

12.1 The County shall save, hold harmless, indemnify and defend the City, its elected and appointed officials, officers, employees and agents, from and against any loss or claim for damages of any nature whatsoever, including claims by third parties or County employees against which it would otherwise be immune under Title 51 RCW or other law, arising out of any act or omission of the County in performance of this Agreement, its elected or appointed officials, officers, employees or agents, except to the extent the loss or claim is attributable to the negligence or willful misconduct of the City, its elected or appointed officials, officers, employees or agents.

12.2 The City shall save, hold harmless, indemnify and defend the County and WATPA, its elected and appointed officials, officers, employees and agents from and against any loss or claim for damages of any nature whatsoever, including claims by third parties or the City employees against which it would otherwise be immune under Title 51 RCW or other law, arising out of any act or omission of the City in performance of this Agreement, its elected or appointed officials, officers, employees or agents, except to the extent the loss or claim is attributable to the negligence or willful misconduct of the County, its elected or appointed officials, officers, employees or agents.

13.0 GOVERNING LAW AND VENUE

This Agreement shall be governed by, construed, and enforced in accordance with the laws of the State of Washington without reference to choice of law principles, and venue of any suit between the

parties arising out of this agreement shall be in the Superior Court of Snohomish County, Washington.

14.0 INTEGRATION

This Agreement constitutes the whole and entire agreement among the parties as to the Task Force and no other understandings, oral, or otherwise, regarding the Task Force shall be deemed to exist or bind the parties.

13.0 SEVERABILITY

If any part of this Agreement is unenforceable for any reason the remainder of the agreement shall remain in full force and effect.

14.0 EXECUTION OF MULTIPLE ORIGINAL COUNTERPARTS

This Agreement may be reproduced in any number of original counterparts. Each party need sign only one counterpart and when the signature pages are all assembled with one original counterpart, that compilation constitutes a fully executed and effective agreement among all the Participating Jurisdictions.

THE REMAINDER OF THIS PAGE HAS BEEN INTENTIONALLY LEFT BLANK

15.0 RECORDING OR POSTING

As provided by RCW 39.34.040, this Agreement shall not take effect unless and until it has (i) been duly executed by both parties, and (ii) either filed with the County Auditor or posted on the County’s Interlocal Agreements website.

Dated this ____ day of _____, 2015

“County”
SNOHOMISH COUNTY

“City”
CITY OF MARYSVILLE

County Executive
Date: _____

Jon Nehring, Mayor
Date: _____

APPROVAL RECOMMENDED:

ATTEST:

Ty Trenary, Sheriff
Dated: _____

By: _____
Print Name: _____
Dated: _____

Approved as to form:

Approved as to form:

Deputy Prosecuting Attorney
Date: _____

Walker, Jon City Attorney
Date: _____

Reviewed by Risk Management

Risk Manager
Date: _____

**Snohomish County Auto Theft Task Force
2015-17 Budget
Annual Amounts**

SECTION I: Reimbursable Detail Budget

Agency	MARYSVILLE	SCPA	SCSO	SCSO	WSP	
FTE	DETECTIVE	Prosecutor	Defective	Defective	Sergeant	Total
Salary	\$ 87,625.00	\$ 181,520.00	\$ 89,250.00	\$ 86,041.50	\$ 100,687.50	\$ 545,124.00
Benefits	\$ 46,391.66	\$ -	\$ 29,925.00	\$ 32,216.50	\$ 21,870.84	\$ 130,403.99
Overtime	\$ 2,000.00	\$ -	\$ 2,000.00	\$ 2,000.00	\$ 850.00	\$ 6,850.00
Overtime Benefits	\$ -	\$ -	\$ -	\$ -	\$ -	\$ -
Agency Total	\$ 136,016.66	\$ 181,520.00	\$ 121,175.00	\$ 120,258.00	\$ 123,408.34	\$ 682,377.99

SECTION II: Reimbursable Category Budget

	Personnel	Benefits	Total Award
SC Prosecutor	\$ 181,520	\$ -	\$ 181,520
SC Sheriff	\$ 241,433	\$ 62,142	\$ 303,575
Unallocated	\$ -	\$ -	\$ -
Marysville	\$ 87,625	\$ 46,392	\$ 134,017
WSP	\$ 100,688	\$ 21,871	\$ 122,558

SECTION III: Operating Budget (Managed by Snohomish County Sheriff)

Training/Travel	\$ 3,250	
Cell Phone	\$ 4,500	
Data/DIS	\$ 25,700	
Space Rent/Supplies	\$ 11,050	
Equipment & Tech	\$ 800	
Vehicle Lease	\$ 16,000	
Fuel/Maintenance	\$ 11,500	Includes fuel costs for WSP Sergeant, maintenance/fuel for Snohomish Co. owned vehicles
Public Awareness	\$ 7,500	
Operating Total	\$ 80,300	

Total Grant Award: \$ 762,678 per year

\$ 0

Index #10

CITY OF MARYSVILLE

EXECUTIVE SUMMARY FOR ACTION

CITY COUNCIL MEETING DATE: October 12, 2015

AGENDA ITEM: Authorize the Mayor to sign the final plat map for Allen Creek Park Snohomish County: PFN 04119115	AGENDA SECTION:	
PREPARED BY: Amy Hess, Assistant Planner	APPROVED BY:	
ATTACHMENTS: 1. Snohomish County Hearing Examiner Decision 2. Minor Modification Approval 3. Final Subdivision Map 4. Final Plat Checklist		
	MAYOR	CAO
BUDGET CODE:	AMOUNT:	

DESCRIPTION:

On April 26, 2006, the Snohomish County Hearing Examiner granted preliminary approval of a 39-lot subdivision, known as “Allen Creek Park,” generally located along 59th Avenue NE at the intersection of 83rd Place NE. On February 28, 2014, a minor modification to the subdivision was filed with the City which proposed to reduce the number of single-family lots from thirty-nine (39) to thirty-two (32) including an amended plat configuration. On April 30, 2014, the City approved the minor modification, amending certain conditions of the preliminary approval granted by the Snohomish County Hearing Examiner.

The subject property was annexed (Central Marysville annexation) into the City of Marysville on December 30, 2009, prior to recording the final subdivision. Since the property was annexed into the City, prior to being recorded by Snohomish County, final subdivision review is required to be conducted by the City of Marysville.

The applicant has satisfied all the conditions of approval, as outlined in the attached Hearing Examiner decision and Minor Modification.

RECOMMENDED ACTION:

Staff recommends City Council authorize the Mayor to sign the final plat map for Allen Creek Park.

COUNCIL ACTION:

BEFORE THE

SNOHOMISH COUNTY HEARING EXAMINER

DECISION of the DEPUTY HEARING EXAMINER
UPON RECONSIDERATION

In the Matter of the Application of)	
)	FILE NO. 04 119115
SCOTT RAY)	
)	
39-lot Planned Residential Development (PRD) on 11.06 acres)	

DATE OF DECISION: April 26, 2006, superseding initial decision entered January 18, 2006.

PLAT/PROJECT NAME: *Allen Creek Park*

DECISION (SUMMARY): The application is **CONDITIONALLY APPROVED**.

BASIC INFORMATION

GENERAL LOCATION: This project is located on both sides of 59th Avenue NE at 83rd Place NE, one-half mile east of the Marysville city limits.

ACREAGE: 11.06 acres

NUMBER OF LOTS: 39

AVERAGE LOT SIZE: 3,494 square feet

MINIMUM LOT SIZE: 2,189 square feet

DENSITY: 3.53 du/ac (gross)
4.89 du/ac (net)

ZONING: Residential-7,200 (R-7,200)

Received
FEB 28 2014
City of Marysville
Community Development

COMPREHENSIVE PLAN DESIGNATION:

General Policy Plan Designation: Urban Low Density Residential (4-6-du/ac)
 Subarea Plan: Marysville
 Subarea Plan Designation: Urban Residential (4-6 du/ac) with Environmentally Sensitive Area overlay

UTILITIES:

Water/Sewer: City of Marysville

SCHOOL DISTRICT: Marysville No. 25

FIRE DISTRICT: No. 12

SELECTED AGENCY RECOMMENDATIONS:Department of:

Planning and Development Services (PDS): Approval subject to conditions
 Public Works (DPW): Approval subject to conditions

INTRODUCTION

The applicant filed the Master Application on December 29, 2004. (Exhibit 1)

The Department of Planning and Development Services (PDS) gave proper public notice of the open record hearing as required by the county code. (Exhibits 26, 27 and 28)

A SEPA determination was made on October 20, 2005. (Exhibit 25) No appeal was filed.

The Examiner held an open record hearing on January 3, 2006, the 95th day of the 120-day decision making period. Witnesses were sworn, testimony was presented and exhibits were entered at the hearing. The Examiner entered a decision on January 18, 2006 denying the application only because it failed to provide safe walking conditions to school (Exhibit 97).

A timely petition for reconsideration was filed by applicant Scott Ray on January 30, 2006 (Exhibit 98).

By Order issued February 1, 2006 (Exhibit 99), the Examiner re-opened the record for comments on the petition for reconsideration. Residents of eleven vicinity households responded pre-hearing in writing (Exhibits 102 through 112).

PUBLIC HEARINGS

The first public hearing commenced on January 3, 2006 at 2:01 p.m.

1. The Examiner indicated that he has read the PDS staff report, reviewed the file and viewed the area and therefore had a general idea of the particular request involved.

2. The applicant, Scott Ray, was represented by himself and by Debbie Rothfus of Peak Engineering. Snohomish County was represented by Bob Pemberton of the Department of Planning and Development Services and by Mark Brown of the Department of Public Works.
3. Citizens submitted approximately 45 letters into the record and approximately 10 citizens testified at the hearing, mostly in general opposition to the lot sizes, density and resultant vehicular traffic generated by 39 new homes on local streets which those citizens feel are inadequate. Some of the letters and testimony raise concern about walking facilities for public school students.

The hearing concluded at 4:22 p.m.

The public hearing upon reconsideration commenced on April 12, 2006 at 1:04 p.m.

4. Upon opening the proceeding, the Examiner disclosed that an ex parte written communication about the merits of the application had been received, provided copies of the document, and allowed time for oral rebuttal of the document before proceeding with the hearing.
5. The applicant, Scott Ray, was represented by himself and by his attorney, Bruce Bell. Snohomish County was represented by Bob Pemberton of the Department of Planning and Development Services and by Ann Goetz of the Department of Public Works. Citizen testimony was given by Holly Faller, Marnie Hargraves, Larry Hazard, Eileen Hope, Geraldine Makus, James Richardson and Susan Richardson.

The hearing concluded at 2:52 p.m.

Note: For a complete record, an electronic recording of each hearing is available in the Office of the Hearing Examiner.

FINDINGS, CONCLUSIONS AND DECISION

FINDINGS OF FACT

Based on all of the evidence of record, the following findings of fact are entered.

1. The master list of exhibits and witnesses which is a part of this file and which exhibits were considered by the Examiner is hereby made a part of this file as if set forth in full herein.
2. The PDS staff report has analyzed the nature of the application, the issues of concern, the application's consistency with adopted codes and policies and land use regulations, and the State Environmental Policy Act (SEPA). That report is hereby adopted by the Examiner as if set forth in full herein unless otherwise stated below.

3. At the core of this matter lies 59th Avenue NE (hereinafter "59th"). Local residents argue that 59th's narrow (only 16 feet) paved roadway cannot reasonably or safely accept the additional 345 average weekday vehicular trips. There is no currently available right-of-way for widening. In response to that issue, the applicant proposes (apparently with the concurrence of the Fire Marshall and DPW) to block traffic along 59th by using removable bollards and a temporary turnaround in 59th at the south boundary of the proposed plat.

4. Local residents assert that not only the 39 homes proposed herein will impact the local streets but other developments in the vicinity will raise that number to 60 homes or more on 59th and on 60th Drive NE. They express concern about Cedarcrest Middle School students walking on 60th to 87th Street because there are no sidewalks on 60th nor crosswalks. It appears to this Hearing Examiner, based on review of the entire record, that conditions upon approval recommended by DPW are adequate to reduce those concerns to the extent consistent with law. The same reasoning applies to the Marysville-Pilchuck High School. Specifically, the applicant will be required to provide safe walkways to 60th Drive NE and 83rd Place NE (a bus stop) from within the proposed plat.
5. However, the evidence of record at the close of the record following the initial hearing had not convinced this Hearing Examiner that the elementary school aged children of the proposed 39 households will have safe walking conditions to and from Pinewood Elementary School. The Marysville School District had accepted the applicant's offer to supply a school bus and its maintenance and operating costs for five years in order to overcome the fact that Pinewood Elementary School is "...currently inaccessible to pedestrians directly from the Project [Allen Creek Park]." (See Exhibit 84.) The School District states that it has negotiated similar alternative walkway mitigation agreements in the past. The staff report notes (p. 7) that the walking route to Pinewood Elementary from the subject plat is circuitous due to the creek, which would require the developer to construct offsite walkways along the shortest legal route between the development and the school in order to satisfy the requirement for safe walking conditions for students.
6. Additional evidence and argument at the second hearing (granted upon reconsideration) convinces this Examiner that the applicant has, in fact, met the burden of demonstrating safe passage to school for all students of the proposed subdivision. As stated by the applicant (Exhibit 117), the applicant will provide a safe walkway for students easterly from the development across a private easement to the intersection of 60th Drive NE and 83rd Place NE, thus completing the missing safe walkway link between the Allen Creek Park project and the existing bus stop at the intersection of 83rd Street NE and 67th Avenue NE. In addition, 58th Avenue will be extended to the north with a lighted safe walkway reaching 83rd Place NE.
7. The subject site is designated Urban Residential with Environmentally Sensitive Area overlay on the pre-GMA Marysville Subarea Plan because Allen Creek and its associated wetlands flow north to south across the westerly one third of the site. However, it is the County's GMA Comprehensive Plan which applies in this matter. Also, the Critical Areas Regulations (SCC 30.62) require that Allen Creek and its wetlands be protected by permanent native growth protection area buffers.
8. The project would comply with park mitigation requirements under Chapter 30.66A SCC (Title 26A SCC) by the payment of \$1,040.00 for each new single-family home.

9. The DPW reviewed the request with regard to traffic mitigation and road design standards. This review covered Title 13 SCC and Chapter 30.66B SCC (Title 26B SCC) as to road system capacity, concurrency, inadequate road conditions, frontage improvements, access and circulation, and dedication/deeding of right-of-way, state highway impacts, impacts on other streets and roads, and Transportation Demand Management. As a result of this review, the DPW has determined that the development is concurrent and has no objection to the requests subject to various conditions.

10. School mitigation requirements under Chapter 30.66C SCC (Title 26C SCC) have been reviewed and set forth in the conditions.

11. Allen Creek with associated wetlands flows north to south across the westerly one third of the site. The creek and wetlands are proposed to remain undisturbed and protected by the establishment of permanently protected Native Growth Protection Area buffers. In addition, 9,347 square feet of enhanced buffer will be established. The stream/wetland treatment is described in the Critical Areas, Habitat Management Plan and Buffer Enhancement Plan contained in the project file. (Exhibit 11) An evaluation of the information submitted with the application coupled with an on-site investigation has resulted in a determination that the application complies with Chapter 30.62 (32.10), SCC (Critical Area Regulations) and is consistent with the purpose and objectives of the Chapter in regulation of development activities in Critical Areas to safeguard the public health, safety and welfare. Testimony of local residents is that Allen Creek is a salmon spawning stream. Related actions and plans for the plat must be consistent with that spawning function of the stream.
12. The PDS Engineering Division has reviewed the concept of the proposed grading and drainage and recommends approval of the project subject to conditions, which would be imposed during full detailed drainage plan review pursuant to Chapter 30.63A SCC (Title 24 SCC).
13. The Snohomish County Health District has no objection to this proposal provided that public water and sewer are furnished.
14. Public water and sewer service will be available for this development as well as electrical power.
15. The subject property is designated Urban Low Density Residential (ULDR: 4-6 DU/Ac) on the GPP Future Land Use map, and is located within an Urban Growth Area (UGA). It is not located within a mapped Growth Phasing Overlay. According to the GPP, the Urban Low Density Residential designation "covers various sub-area plan designations, which allow mostly detached housing developments on larger lot sizes. Land in this category may be developed at a density of four to six dwelling units per acre. Implementing zones include the R-7200, which is the case here.
16. The application is required to meet requirements for a planned residential development set out at SCC 30.42B and the subdivision requirements of 30.41A. A boundary line adjustment affidavit is in the record and the Examiner concurs with the recommendation of approval of that boundary line adjustment. The staff report reviews in detail the proposal's compliance with PRD and plat regulations covering unit yield and bonus, design criteria and open space, drainage, landscaping, tree retention and transportation and parking.
17. The request is consistent with Section 30.70.100 SCC (Section 32.50.100 SCC), which requires, pursuant to RCW 36.70B.040, that all project permit applications be consistent with the GMACP, and GMA-based county codes.
18. Any finding of fact in this decision which should be deemed a conclusion is hereby adopted as such.

CONCLUSIONS OF LAW

1. The Examiner has fully reviewed the PDS staff report and, to the extent that the staff report is consistent with this decision, hereby adopts said staff report as properly setting forth the issues, the land use requests, consistency with the existing regulations, policies, principles, conditions and their effect upon the request. It is adopted by the Examiner as a conclusion as if set forth in full herein in order to avoid needless repetition.

2. The request is consistent with the (1) GMACP, GMA-based County codes, (2) the type and character of land use permitted on the site, (3) the permitted density, and (4) the applicable design and development standards.
3. The Department of Public Works recommends that the request be approved as to traffic use subject to specific conditions. The Examiner concurs and specifically concludes as a matter of law that the safe walking pathway proposed along 83rd Place NE/834d Street NE to the state-funded bussing to Pinewood Elementary School from the bus stop at 67th Avenue NE meets the health, safety and general welfare mandate of RCW 58.17.110, which has insisted for at least 35 years that a plat in Washington State must provide safe walking conditions for school students. Specifically, Section 110 provides in pertinent part:

“(1) The...county...shall determine...if appropriate provisions are made for...sidewalks and other planning features that assure safe walking conditions for students who only walk to and from school;....”

“(2) A proposed subdivision ...shall not be approved unless the...county makes written findings that...[A]ppropriate provisions are made for...sidewalks and other planning features that assure safe walking conditions for students who only walk to and from school;....”
4. The request should be approved subject to compliance by the applicant with the following conditions:

CONDITIONS

- A. The PRD official site plan/preliminary plat received by the Department of Planning and Development Services on December 21, 2005 (Exhibit 16) shall be the PRD official site plan and approved plat configuration. SCC 30.42B.220 governs changes to the planned residential development official site plan; changes to the approved plat are governed by SCC 30.41A.330.
- B. Prior to initiation of any further site work; and/or prior to issuance of any development/construction permits by the county:
 - i. All site development work shall comply with the requirements of the plans and permits approved pursuant to Condition A, above.
 - ii. The platlor shall mark with temporary markers in the field the boundary of all Native Growth Protection Areas (NGPA) required by Chapter 30.62 SCC, or the limits of the proposed site disturbance outside of the NGPA, using methods and materials acceptable to the county.
 - iii. A final mitigation plan based on the Critical Areas, Habitat Management Plan and Buffer Enhancement Plan prepared by Wetland Resources dated December 27, 2004 (Exhibit 11) and Addendum dated June 6,

2005 (Exhibit 23), shall be submitted for review and approval during the construction review phase of this project.

- iv. A detailed landscape and recreational facilities plan shall have been submitted to and approved by the Department of Planning and Development Services. The plan shall be prepared in general conformance with Exhibit 20 and in conformance with all required landscape standards for perimeter, streetscape and open space treatment, and shall include a significant tree retention plan.

C. The following additional restrictions and/or items shall be indicated on the face of the final plat:

i. "The lots within this subdivision will be subject to school impact mitigation fees for the Marysville School District No. 25 to be determined by the certified amount within the Base Fee Schedule in effect at the time of building permit application, and to be collected prior to building permit issuance, in accordance with the provisions of SCC 30.66C.010. Credit shall be given for three existing residential units. Lots 1, 2 and 26 shall receive credit."

ii. Chapter 30.66B SCC requires the new lot mitigation payments in the amounts shown below for each single-family residential building permit:

\$1,813.39 per lot for mitigation of impacts on county roads paid to the County,

\$335.21 per lot for mitigation of impacts to state highways,

\$1,212.26 per lot for mitigation of impacts on the City of Marysville streets paid to the City.

\$204.01 per lot for mitigation of impacts on the City of Arlington streets paid to the City

The developer of this subdivision has elected to defer these payment obligations to a time preceding building permit issuance. Notice of these mitigation payment obligations shall be contained in any deeds involving this subdivision or the lots therein. Once a building permit has been issued all mitigation payments for that lot shall be deemed paid.

iii. On lots with more than one road frontage, county Engineering Design and Development Standards (EDDS) restricts lot access to the minor road, unless the Department of Public Works grants a formal deviation.

iv. All Critical Areas shall be designated Native Growth Protection Areas (NGPA) (unless other agreements have been made) with the following language on the face of the plat;

"All NATIVE GROWTH PROTECTION AREAS shall be left permanently undisturbed in a substantially natural state. No clearing, grading, filling, building construction or placement, or road construction of any kind shall occur, except removal of hazardous trees. The activities as set forth in SCC 32.10.110(29)(a), (c), and (d) are allowed when approved by the County."

v. "All open space shall be protected as open space in perpetuity. Use of the open space tracts within this subdivision is restricted to those uses approved for the planned residential development, to include open play areas, picnic areas, recreation trail system, viewing platform, drainage facilities, benches and required landscape improvements as shown on the approved site plan and the approved landscape plan. Covenants,

conditions and restrictions as recorded with the plat, and as may be amended in the future, shall include provisions for the continuing preservation and maintenance of the uses, facilities and landscaping within the open space as approved and constructed.”

D. Prior to recording of the final plat:

- i. The developer shall pay the County \$1,040.00 per new dwelling unit as mitigation for parks and recreation impacts in accordance with Chapter 30.66A SCC; provided, however, the developer may elect to postpone payment of the mitigation requirement until issuance of a building permit for that lot. The election to postpone payment shall be noted by a covenant placed on the face of the recorded plat and included in the deed for each affected lot within the subdivision.
- ii. The developer shall have constructed an offsite walkway from Allen Creek Park along 83rd Place NE to its intersection with 60th Drive NE to the nearest bus stop location for the public school students as identified by the Marysville School District (currently the intersection of 60th Drive NE and 83rd Place NE). Additionally, the developer shall have provided \$150,000 in additional mitigation for the purchase of a school bus to be provided to the Marysville School District, with any remaining balance of said \$150,000 to be used by the District toward its school bus maintenance expenses in the future or for other bus transportation purposes. The school district, the applicant and DPW shall concur with the agreement. [RCW 58.17.110]
- iii. Bollards or a barrier that meet EDDS requirements and/or the Fire Marshal's requirements shall block access to the south on 59th Avenue NE until such time that it has been constructed to minimum county design standards from the subject property to Grove Street. A temporary turnaround shall have been constructed south of the bollards/barrier as a turnaround for the south section of 59th Avenue NE.
- iv. The residents on the east side of 59th Avenue that presently have access to the south section of 59th Avenue NE shall be provided with a paved driveway on the east side of an extruded curb or fence divided from the improved "half" road in such a manner that those residents retain access to the south if they so desire, but the Allen Creek Park residents would not. Those existing residents would be provided with a driveway opening in the curb/fence that would allow them to access the new north section of 59th Avenue NE if they so desire.
- v. 83rd Place NE shall have been constructed to 60th Avenue NE to adequate public "half" road standards with a minimum of a 20-foot pavement width.
- vi. 59th Avenue NE shall have been constructed to full public road standards between the north property line and 83rd Place NE, and to adequate public "half" road standards with a minimum of a 20-foot pavement width between 83rd Place NE and the bollards/barrier location (as shown on the 9/14/05 plans).
- vii. Native Growth Protection Area boundaries (NGPA) shall have been permanently marked on the site prior to final inspection by the county, with both NGPA signs and adjacent markers which can be magnetically located (e.g.: rebar, pipe, 20 penny nails, etc.). The platlor may use other permanent methods and materials provided they are first approved by the county. Where an NGPA boundary crosses another boundary (e.g.: lot, tract, plat, road, etc.), a rebar marker with surveyors' cap and license number must be placed at the line crossing.

NGPA signs shall have been placed no greater than 100 feet apart around the perimeter of the NGPA. Minimum placement shall include one Type 1 sign per wetland, and at least one Type 1 sign shall be placed in

any lot that borders the NGPA, unless otherwise approved by the county biologist. The design and proposed locations for the NGPA signs shall be submitted to the Land Use Division for review and approval prior to installation.

- viii. The final wetland mitigation plan shall be completely implemented.
 - ix. A bond or other guarantee of performance shall have been submitted to and accepted by PDS to assure compliance with the provisions of SCC 30.42B.125.
 - x. PRD covenants, deeds and homeowners' association bylaws and other documents shall have been submitted to and approved by PDS guaranteeing maintenance of open space, community facilities, private roads and drives, and all other commonly-owned and operated property. The documents shall have been reviewed by and accompanied by a certificate from an attorney that they comply with Chapter 30.42B SCC requirements prior to approval by PDS. To ensure permanent, ongoing maintenance of landscape areas, landscape maintenance covenants shall be prepared by the applicant and submitted together with documents otherwise required for maintenance of site improvements pursuant to SCC 30.42B.250.
- E. In conformity with applicable standards and timing requirements:
- i. The preliminary landscape plan (Exhibit 20) shall be implemented. All required detention facility landscaping shall be installed in accordance with the approved landscape plan.
- F. All development activity shall conform to the requirements of Chapter 30.63A SCC.
5. Any conclusion in this report and decision which should be deemed a finding of fact is hereby adopted as such.

Nothing in this permit/approval excuses the applicant, owner, lessee, agent, successor or assigns from compliance with any other federal, state or local statutes, ordinances or regulations applicable to this project.

Preliminary plats which are approved by the county are valid for five (5) years from the date of approval and must be recorded within that time period unless an extension has been properly requested and granted pursuant to SCC 30.41A.300.

DECISION

Based on the findings of fact and conclusions of law entered above, the decision of the Hearing Examiner on the application is as follows:

The request for a 39-lot Planned Residential Development Subdivision on 11.06 acres is **CONDITIONALLY APPROVED** subject to the stipulations at Conclusion of Law 3 and 4 above.

Decision issued this 26th day of April 2006

Hearing Examiner

Ed Good, Deputy

EXPLANATION OF APPEAL PROCEDURES

This decision of the Hearing Examiner following reconsideration is final and conclusive and may be appealed to the County Council. No further requests for reconsideration will be accepted. The following paragraphs summarize the appeal process.

An appeal may be filed by any aggrieved Party of Record. If a petition for reconsideration has been filed, issues subsequently raised by that party (and only that party) on appeal to the county council shall be limited to those issues raised in that petition for reconsideration. Appeals shall be addressed to the Snohomish County Council but shall be filed in writing with the Department of Planning and Development Services, 2nd Floor, County East Administration Building, 3000 Rockefeller Avenue, Everett, Washington (Mailing address: M/S #604, 3000 Rockefeller Avenue, Everett, WA 98201) on or before **MAY 10, 2006** and shall be accompanied by a filing fee in the amount of five hundred dollars (\$500.00); PROVIDED, that the filing fee shall not be charged to a department of the county or to other than the first appellant; and PROVIDED FURTHER, that the filing fee shall be refunded in any case where an appeal is dismissed without hearing because of untimely filing, lack of standing, lack of jurisdiction or other procedural defect.

An appeal must contain the following items in order to be complete: a detailed statement of the grounds for appeal; a detailed statement of the facts upon which the appeal is based, including citations to specific Hearing Examiner Findings, Conclusions, exhibits or oral testimony; written arguments in support of the appeal; the name, mailing address and daytime telephone number of each appellant, together with the signature of at least one of the appellants or of the attorney for the appellant(s), if any; the name, mailing address, daytime telephone number and signature of the appellant's agent or representative, if any; and the required filing fee.

The grounds for filing an appeal are limited to the following:

- (a) The decision exceeded the Hearing Examiner's jurisdiction;
- (b) The Hearing Examiner failed to follow the applicable procedure in reaching the decision;
- (c) The Hearing Examiner committed an error of law; or
- (d) The Hearing Examiner's findings, conclusions and/or conditions are not supported by substantial evidence in the record.

Appeals will be processed and considered by the County Council pursuant to the provisions of Chapter 30.72 SCC. Please include the county file number in any correspondence regarding this case. For more information about reconsideration and appeal procedures, please see Chapter 30.72 SCC and the respective Examiner and Council rules of procedure.

Distribution:

Parties of record

The following statement is provided pursuant to RCW 36.70B.130: "Affected property owners may request a change in valuation for property tax purposes notwithstanding any program of revaluation." A copy of this Decision is being provided to the Snohomish County Assessor as required by RCW 36.70B.130.



COMMUNITY DEVELOPMENT DEPARTMENT
 80 Columbia Avenue ♦ Marysville, WA 98270
 (360) 363-8100 ♦ (360) 651-5099 FAX

April 30, 2014

George Newman
 Barghausen Consulting Engineers, Inc.
 18215 72nd Ave South
 Kent, WA 98032

Re: Allen Creek Park – *Minor Modification Approval*
 PFN04119115

Dear George,

The Community Development Department received the minor modification to the above referenced subdivision, on February 28, 2014, proposing to reduce the number of single-family lots from thirty-nine (39) to thirty-two (32) including an amended plat configuration. After review of the minor modification, in accordance with SCC 30.70.210 *Minor revisions to approved development applications*, the Director has determined 1) the minor modification does not substantially alter the previous approval of the development application; 2) the minor modification does not substantially alter the final conditions of approval; and 3) the minor modification does not substantially alter the public health, safety and welfare.

Therefore, the proposed minor modification is **APPROVED**, subject to the following amended conditions of the preliminary approval granted by the Snohomish County Hearing Examiner, on April 26, 2006:

1. The PRD official site plan/preliminary plat received by the Community Development Department on April 28, 2014~~Department of Planning and Development Services on December 21, 2005 (Exhibit 16)~~ shall be the PRD official site plan and approved plat configuration. SCC 36.42B.220 governs changes to the planned residential development official site plan; changes to the approved plat are governed by SCC 30.41A.330.
2. Prior to initiation of any further site work; and/or prior to issuance of any development/construction permits by the city/county:
 - a) All site development work shall comply with the requirements of the plans and permits approved pursuant to Condition 1A, above.
 - b) The platter shall mark with temporary markers in the field the boundary of all Native Growth Protection Areas (NGPA) required by Chapter 22E.010 MMC30.62-SCC, or the limits of the proposed site disturbance outside of the NGPA, using methods and materials acceptable to the city/county.
 - c) A final mitigation plan based on the Critical Areas, Habitat Management Plan and Buffer Enhancement Plan prepared by Wetland Resources dated December 27, 2004 (Exhibit 11) and Addendum dated June 6, 2005 (Exhibit 23), shall be submitted for review and approval during the construction review phase of this project.
 - d) A detailed landscape and recreational facilities plan shall have been submitted to an approved by the Community Development Department of Planning and Development Services. The plan shall be prepared in general conformance with Exhibit 20 and in

conformance with all required landscape standards for perimeter, streetscape and open space treatment, and shall include a significant tree retention plan.

3. The following additional restrictions and/or items shall be indicated on the face of the final plat:

a) "The lots within this subdivision will be subject to school impact mitigation fees for the Marysville School District No. 25 to be determined by the certified amount within the Base Fee Schedule in effect at the time of building permit application, and to be collected prior to building permit issuance, in accordance with the provisions of Chapter 22D.010 MMC SCC-30.66C-010. Credit shall be given for three existing residential units. Lots 1, 2, and ~~326~~ shall receive credit."

b) Chapter 30.66 SCC requires the new lot mitigation payments in the amounts shown below for each single-family residential building permit:

~~\$1,813.39~~ per lot for mitigation of impacts on county roads paid to the County;

\$335.21 per lot for mitigation of impacts to state highways;

\$3,025.65~~\$1,212.26~~ per lot for mitigation of impacts on the City of Marysville streets paid to the City; and

\$204.01 per lot for mitigation of impacts on the City of Arlington streets paid to the City.

The developer of this subdivision has elected to defer these payment obligations to a time preceding building permit issuance. Notice of these mitigation payment obligations shall be contained in any deeds involving this subdivision or the lots therein. Once a building permit has been issued all mitigation payments for that lot shall be deemed paid.

c) On lots with more than one road frontage, ~~city~~county Engineering Design and Development Standards (EDDS) restricts lot access to the minor road, unless the Department of Public Works grants a formal deviation.

d) All Critical Areas shall be designated Native Growth Protection Areas (NGPA) (unless other agreements have been made) with the following language on the face of the plat:

"All NATIVE GROWTH PROTECTION AREAS shall be left permanently undisturbed in a substantially natural state. No clearing, grading, filling, building construction or placement, or road construction of any kind shall occur, except removal of hazardous trees. The activities as set forth in Chapter 22E.010 MMCSCC-32.10.110(29)(a), (c), and (d) are allowed when approved by the ~~City~~County."

e) "All open space shall be protected as open space in perpetuity. Use of the open space tracts within this subdivision is restricted to those uses approved for the planned residential development, to include open play areas, picnic areas, recreation trail system, viewing platform, drainage facilities, benches and required landscape improvements as shown on the approved site plan and the approved landscape plan. Covenants, conditions and restrictions as recorded with the plat, and as may be amended in the future, shall include provisions for the continuing preservation and maintenance of the uses, facilities and landscaping within the open space as approved and constructed."

f) Easement and maintenance language for the required five (5) foot perimeter landscape buffer.

4. Prior to recording of the final plat:

a) The developer shall pay the ~~City~~County \$1,040.00 per new dwelling unit as mitigation for parks and recreation impacts in accordance with Chapter 22D.020 MMC30.66A-SCC; provided, however, the developer may elect to postpone payment

of the mitigation requirement until issuance of a building permit for that lot. The election to postpone payment shall be noted by a covenant placed on the face of the recorded plat and included in the deed for each affected lot within the subdivision.

- b) The developer shall have constructed an offsite walkway from Allen Creek Park along 83rd Place NE to its intersection with 60th Drive NE to the nearest bus stop location for the public school students as identified by the Marysville School District (currently the intersection of 60th Drive NE and 83rd Place NE). Additionally, the developer shall have provided ~~\$106,000~~\$150,000 in additional mitigation for the purchase of a school bus to be provided to the Marysville School District, with any remaining balance of said ~~\$106,000~~\$150,000 to be used by the District toward its school bus maintenance expenses in the future or for other bus transportation purposes. The school district, the applicant and Community Development Department DPW shall concur with the agreement. [RCW 58.17.110]
- c) Bollards or a barrier that meet EDDS requirements and/or the Fire Marshal's requirements shall block access to the south on 59th Avenue NE until such time that it has been constructed to minimum ~~city~~county design standards from the subject property to Grove Street. A temporary turnaround shall have been constructed south of the bollards/barrier as a turnaround for the south section of 59th Avenue NE.
- ~~d) The residents on the east side of 59th Avenue that presently have access to the south section of 59th Avenue NE shall be provided with a paved driveway on the east side of an extruded curb or fence divided from the improved "half" road in such a manner that those residents retain access to the south if they so desire, but the Allen Creek Park residents would not. Those existing residents would be provided with a driveway opening in the curb/fence that would allow them to access the new north section of 59th Avenue NE if they so desire.~~
- e) 83rd Place NE shall have been constructed to 60th Avenue NE to adequate public "half" road standards with a minimum of a 20-foot pavement width.
- f) 59th Avenue NE shall have been constructed to full public road standards between the north property line and 83rd Place NE, and to adequate public "half" road standards with a minimum of a 20-foot pavement width between 83rd Place NE and the bollards/barrier location ~~(as shown on the 9/14/05 plans)~~.
- g) Native Growth Protection Area boundaries (NGPA) shall have been permanently marked on the site prior to final inspection by the ~~city~~county, with both NGPA signs and adjacent markers which can be magnetically located (e.g.: rebar, pipe, 20 penny nails, etc.). The platter may use other permanent methods and materials provided they are first approved by the ~~city~~county. Where an NGPA boundary crosses another boundary (e.g.: lot, tract, plat, road, etc), a rebar marker with surveyors' cap and license number must be placed at the line crossing.

NGPA signs shall have been placed no greater than 100 feet apart around the perimeter of the NGPA. Minimum placement shall include one ~~NGPA~~Type-1 sign per wetland, and at least on ~~NGPA~~Type-1 sign shall be placed in any lot that borders the NGPA, unless otherwise approved by the ~~city~~county biologist. The design and proposed locations for the NGPA signs shall be submitted to the Community Development Department~~Land Use Division~~ for review and approval prior to installation.
- h) The final wetland mitigation plan shall be completely implemented.
- i) A bond or other guarantee of performance shall have been submitted to and accepted by the Community Development Department PDS to assure compliance with the provisions of Chapter 22E.010 MMCSCG 30.42B.125.
- j) PRD covenants, deeds and homeowners' association bylaws and other documents shall have been submitted to and approved by the Community Development Department PDS guaranteeing maintenance of open space, community facilities,

private roads and drives, and all other commonly-owned and operated property. The documents shall have been reviewed by and accompanied by a certificate from an attorney that they comply with Chapter 30.42B SCC requirements prior to approval by the Community Development DepartmentPDS. To ensure permanent, ongoing maintenance of landscape areas, landscape maintenance covenants shall be prepared by the applicant and submitted together with documents otherwise required for maintenance of site improvements pursuant to SCC 30.42B.250.

5. In conformity with applicable standards and timing requirements:
 - a) The preliminary landscape plan (Exhibit 20) shall be implemented. All required detention facility landscaping shall be installed in accordance with the approved landscape plan.
6. All development activity shall conform to the requirements of Chapter 14.15 MMC30-63A SCC.
7. A quality sight-obscuring wood fence shall be constructed along the outer edge of the required five (5) foot perimeter landscape easements.
8. As mitigation for removal of the non-native Ponderosa pine trees along the southern perimeter of the PRD, the developer shall be required to install a minimum of eighteen (18) evergreen trees, along the NGPA buffer adjacent to Lots 25 - 27, measuring a minimum of six (6) feet in height at the time of planting.
9. The lots and roads located within the 300' Riparian Management Zone (RMZ) shall not allow any "effective impervious surface" within the RMZ. Effective impervious surface means that fraction of impervious surface producing stormwater runoff that is not infiltrated into soil. The applicant shall be required to demonstrate no effective impervious surface within the RMZ, prior to construction plan approval.
10. The developer shall be required to connect 8211 59th Avenue NE to public water and sewer and pay all capital improvement connection charges, prior to recording the PRD. The existing on-site sewage system shall be abandoned by having the septic tank pumped by a certified pumper, then having the top of the tank removed or destroyed and filling the void (WAC 246-272A-0300). Documentation demonstrating completion of this work shall be submitted to the Community Development Department.
11. The developer shall be required to construct the following improvements for the current residents of 8205 59th Avenue NE, as outlined in the agreement between the applicant and Betty Hebert, prior to recording the PRD.
 - a) Connect the existing residence to city water, including all water pipe and hook-ups, including PRV, kitchen, washing machine, hot water tank and bathroom. Capital improvement charges shall be paid by the developer.
 - b) Connect the existing residence to city sewer, including sewer hook-ups to all drains in the home which includes three (3) existing drains (kitchen, washing machine and bathroom. Capital improvement charges shall be paid by the developer.
 - c) The existing on-site sewage system(s) shall be abandoned by having the septic tank(s) pumped by a certified pumper, then having the top of the tank removed or destroyed and filling the void (WAC 246-272A-0300). Documentation demonstrating completion of this work shall be submitted to the Community Development Department.
 - d) A paved asphalt driveway shall be installed from the 59th Avenue NE to the garage.
 - e) Landscaping shall be installed within the front yard to create a sense of privacy. Any disturbance to the existing landscaping shall be restored to original and/or better condition and any landscaping must be mutually agreed upon. No plants, trees, shrubs, etc. shall be removed without written prior consent from Betty Hebert or current residents.

- f) It at any time during construction of the PRD the existing well is compromised, connection to City of Marysville water shall be made within seven (7) days of notice.

If you have any questions regarding the revised conditions associated with the minor modification approval, please contact me at cholland@marysvillewa.gov, or by phone at 360.363.8207.

Sincerely,



Chris Holland
Planning Manager

cc: Gloria Hirashima, CAO/CD Director
Scott Ray, owner/applicant

PRELIMINARY PLAT MAP OF ALLEN CREEK PARK A PORTION OF NE1/4 OF SW1/4, SECTION 22, TOWNSHIP 30 N, RANGE 05 E, W.M. SNOHOMISH COUNTY, WA

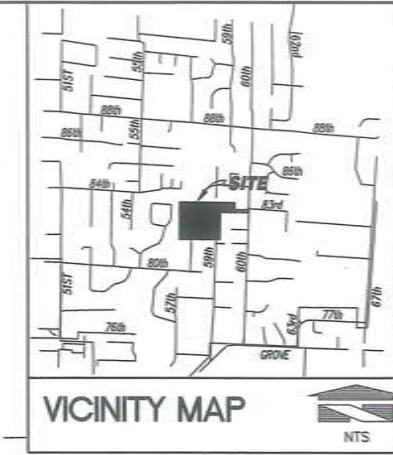
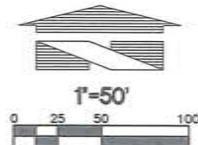

APPROVED Date: 4/30/14

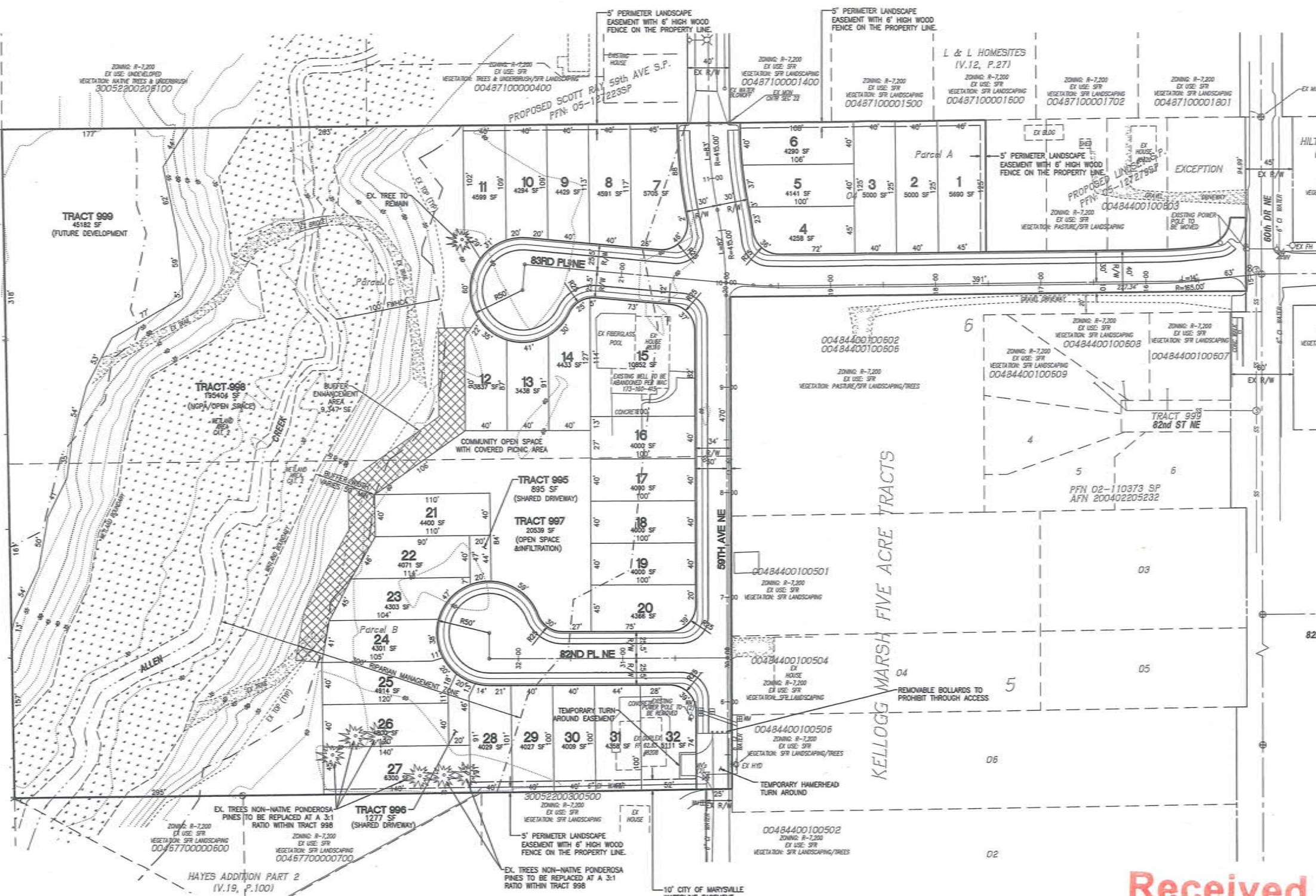

SITE INFORMATION: TOTAL SITE AREA: 11.23 AC (489,035 ± SF) EXISTING/PROPOSED ZONING: R-7200 NUMBER OF LOTS PROPOSED: 32 AVERAGE LOT SIZE: 4,080 SF SIZE OF SMALLEST PROPOSED LOT: 3,438 SF

PUBLIC UTILITIES AND SERVICES: WATER PURVEYOR: PUBLIC - CITY OF MARYSVILLE SEWER PURVEYOR: SANITARY SEWER - CITY OF MARYSVILLE FIRE PROTECTION: FIRE DISTRICT NO. 12 PUBLIC SCHOOLS: MARYSVILLE SCHOOL DISTRICT NO. 25

LEGAL DESCRIPTION: THE S1/2 OF THE NE1/4 OF THE NE1/4 OF THE SW1/4 OF SECTION 22, TOWNSHIP 30 NORTH, RANGE 5 EAST, W.M.; AND THE N1/2 OF THE NE1/4 OF THE SW1/4 OF SECTION 22, TOWNSHIP 30 NORTH, RANGE 5 EAST, W.M.;

ON-SITE RECREATION: OPEN SPACE REQUIRED (20% OF GROSS SITE AREA): 97,807 SF TOTAL OPEN SPACE PROVIDED: 215,991 SF (44%)

PROJECT MANAGER/PLANNER: BARGHAUSEN CONSULTING ENGINEERS, INC. 18215 72ND AVE. SOUTH KENT, WA 98032

OWNER/APPLICANT: SCOTT R. RAY 8310 59TH AVE NE MARYSVILLE, WA 98271

OFF STREET PARKING*: REQUIRED PARKING RESIDENCE - 2 PER UNIT = 64 TOTAL = 64

ENCUMBRANCES: THIS PRELIMINARY SUBMISSION/PRD IS SUBJECT TO THE FOLLOWING ENCUMBRANCES WHICH ARE NOT PLATABLE: 1. PUGET SOUND POWER AND LIGHT CO. EASEMENT (AFN 491859)

DENSITY CALCULATION CITY OF MARYSVILLE: NET AREA = GROSS AREA LESS ROADS, DEDICATION, DETENTION TRACT GROSS SITE AREA: 489,035 SF

MINIMUM NET DENSITY CALCULATION SNOHOMISH COUNTY: NET AREA = GROSS AREA LESS ROADS, DEDICATION, DETENTION TRACT GROSS SITE AREA: 489,035 SF

Received APR 28 2014 City of Marysville Community Development

Job Number 16878, Sheet 1 of 1, Title: PRELIMINARY PLAT MAP ALLEN CREEK PARK, For: SCOTT R. RAY 8310 59TH AVE NE MARYSVILLE, WA 98271 (425) 359-1745

VOL/Pg

ALLEN CREEK PARK

NE 1/4, SW 1/4, SEC. 22, AND NW 1/4, SE 1/4, SEC. 22, T. 30 N., R. 5 E., W.M.
CITY OF MARYSVILLE, SNOHOMISH COUNTY, WASHINGTON (PFN. 04-119115 SD)

DEDICATION:

KNOW ALL MEN BY THESE PRESENTS THAT ALLEN CREEK PARK, LLC, A WASHINGTON LIMITED LIABILITY COMPANY THE UNDERSIGNED OWNER(S), IN FEE SIMPLE OF THE LAND HEREBY PLATTED, AND SPRINGLINE CAPITAL, LLC, THE MORTGAGEE THEREOF, HEREBY DECLARE THIS PLAT AND DEDICATE TO THE USE OF THE PUBLIC FOREVER ALL STREETS, AVENUES, PLACES AND SEWER EASEMENTS OR WHATEVER PUBLIC PROPERTY THERE IS SHOWN ON THE PLAT AND THE USE FOR ANY AND ALL PUBLIC PURPOSES NOT INCONSISTENT WITH THE USE THEREOF FOR PUBLIC HIGHWAY PURPOSES. ALSO, THE RIGHT TO MAKE ALL NECESSARY SLOPES FOR CUTS AND FILLS UPON LOTS, BLOCKS, TRACTS, ETC. SHOWN ON THIS PLAT IN THE REASONABLE ORIGINAL GRADING OF ALL THE STREETS, AVENUES, PLACES, ETC. SHOWN HEREON. ALSO, THE RIGHT TO DRAIN ALL STREETS OVER AND ACROSS ANY LOT OR LOTS WHERE WATER MIGHT TAKE A NATURAL COURSE AFTER THE STREET OR STREETS ARE GRADED. ALSO, ALL CLAIMS FOR DAMAGE AGAINST ANY GOVERNMENTAL AUTHORITY ARE WAIVED WHICH MAY BE OCCASIONED TO THE ADJACENT LAND BY THE ESTABLISHED CONSTRUCTION, DRAINAGE, AND MAINTENANCE OF SAID ROADS.

FOLLOWING ORIGINAL REASONABLE GRADING OF THE ROADS AND WAYS HEREON, NO DRAINAGE WATERS ON ANY LOT OR LOTS SHALL BE DIVERTED OR BLOCKED FROM THEIR NATURAL COURSE SO AS TO DISCHARGE UPON ANY PUBLIC ROAD RIGHTS-OF-WAY TO HAMPER PROPER ROAD DRAINAGE. THE OWNER OF ANY LOT OR LOTS, PRIOR TO MAKING ANY ALTERATION IN THE DRAINAGE SYSTEM AFTER THE RECORDING OF THIS PLAT, MUST MAKE APPLICATION TO AND RECEIVE APPROVAL FROM THE DIRECTOR OF THE DEPARTMENT OF PUBLIC WORKS FOR SAID ALTERATION. ANY ENCLOSING OF DRAINAGE WATERS IN CULVERTS OR DRAINS OR REROUTING THEREOF ACROSS ANY LOT AS MAY BE UNDERTAKEN BY OR FOR THE OWNER OF ANY LOT SHALL BE DONE BY AND AT THE EXPENSE OF SUCH OWNER.

A "TRACT" IS LAND RESERVED FOR SPECIFIC USES INCLUDING, BUT NOT LIMITED TO, RESERVE TRACTS, RECREATION, OPEN SPACE, SENSITIVE AREAS, SURFACE WATER RETENTION, UTILITY FACILITIES AND ACCESS. TRACTS ARE NOT CONSIDERED LOTS FOR BUILDING SITES FOR PURPOSES OF RESIDENTIAL DWELLING CONSTRUCTION.

TRACT 995 IS FOR ACCESS AND UTILITIES AND IS HEREBY CONVEYED IN AN EQUAL AND UNDIVIDED INTEREST TO THE OWNERS OF LOTS 21 AND 22, ALONG WITH ALL MAINTENANCE OBLIGATIONS FOR THE FACILITIES WITHIN SAID TRACTS UPON THE RECORDING OF THIS PLAT, WITH THE EXCEPTION THAT THE CITY OF MARYSVILLE SHALL BE RESPONSIBLE FOR THE OWNERSHIP AND MAINTENANCE OF THE SEWER FACILITIES WITHIN THE PUBLIC SEWER EASEMENTS SHOWN WITHIN SAID TRACTS. ANY CONVEYANCE OF LOTS 21 OR 22 SHALL INCLUDE AN UNDIVIDED OWNERSHIP INTEREST IN TRACT 995.

TRACT 996 IS FOR ACCESS AND UTILITIES AND IS HEREBY CONVEYED IN AN EQUAL AND UNDIVIDED INTEREST TO THE OWNERS OF LOTS 26 AND 27, ALONG WITH ALL MAINTENANCE OBLIGATIONS FOR THE FACILITIES WITHIN SAID TRACTS UPON THE RECORDING OF THIS PLAT, WITH THE EXCEPTION THAT THE CITY OF MARYSVILLE SHALL BE RESPONSIBLE FOR THE OWNERSHIP AND MAINTENANCE OF THE SEWER FACILITIES WITHIN THE PUBLIC SEWER EASEMENTS SHOWN WITHIN SAID TRACTS. ANY CONVEYANCE OF LOTS 26 OR 27 SHALL INCLUDE AN UNDIVIDED OWNERSHIP INTEREST IN TRACT 996.

TRACT 997, TOGETHER WITH DRAINAGE AND DETENTION FACILITIES IS HEREBY GRANTED AND CONVEYED TO THE ALLEN CREEK PARK HOMEOWNER'S ASSOCIATION (HOA) UPON RECORDING OF THIS PLAT, SUBJECT TO BOTH AN EMERGENCY AND ROUTINE MAINTENANCE EASEMENT GRANTED AND CONVEYED TO THE CITY OF MARYSVILLE. OWNERSHIP AND EXTERIOR MAINTENANCE OF SAID TRACT, CONSISTENT WITH THE CITY OF MARYSVILLE CODE, SHALL BE THE RESPONSIBILITY OF THE ALLEN CREEK PARK HOMEOWNER'S ASSOCIATION (HOA). USE OF SAID TRACT IS RESTRICTED TO THAT SPECIFIED IN THE APPROVED FINAL PLAT. THE ALLEN CREEK PARK HOMEOWNERS ASSOCIATION (HOA) SHALL COMPLY WITH THOSE CITY OF MARYSVILLE REGULATIONS AND CONDITIONS OF FINAL SUBDIVISION APPROVAL SPECIFIED ON THE PLAT. IN THE EVENT THAT THE CITY OF MARYSVILLE SHALL BE REQUIRED TO MAKE CHANGES TO DRAINAGE OR DETENTION FACILITIES, CITY RIGHTS SHALL BE PRIMARY AND HOLD PRECEDENCE OVER THE SURFACE RIGHTS RESERVED BY ALLEN CREEK PARK HOMEOWNER'S ASSOCIATION (HOA). THE CITY MAY TAKE ALL SUCH ACTS AS REASONABLY REQUIRED TO PRESERVE, PROTECT, AND MAINTAIN ITS IMPROVEMENTS. THE HOA SHALL REMAIN IN EXISTENCE UNLESS AND UNTIL ALL LOTS WITHIN THIS SUBDIVISION HAVE ASSUMED COMMON OWNERSHIP OF SAID TRACT. IN THE EVENT THAT THE HOA SHOULD BE DISSOLVED, THEN EACH LOT SHALL HAVE AN EQUAL AND UNDIVIDED OWNERSHIP INTEREST IN THE TRACT PREVIOUSLY OWNED BY THE HOA AS WELL AS SAME RESPONSIBILITY FOR MAINTAINING THE TRACT.

TRACT 998 (OPEN SPACE NGPA TRACT) IS HEREBY GRANTED AND CONVEYED ALONG WITH ALL MAINTENANCE OBLIGATIONS TO THE ALLEN CREEK PARK HOMEOWNER'S ASSOCIATION (HOA) UPON RECORDING OF THIS PLAT, SUBJECT TO AN EMERGENCY MAINTENANCE EASEMENT GRANTED AND CONVEYED TO THE CITY OF MARYSVILLE. THE HOA SHALL REMAIN IN EXISTENCE UNLESS AND UNTIL ALL LOTS WITHIN THIS SUBDIVISION HAVE ASSUMED COMMON OWNERSHIP OF SAID TRACT. IN THE EVENT THAT THE HOA SHOULD BE DISSOLVED, THEN EACH LOT SHALL HAVE AN EQUAL AND UNDIVIDED OWNERSHIP INTEREST IN THE TRACT PREVIOUSLY OWNED BY THE HOA AS WELL AS RESPONSIBILITY FOR MAINTAINING THE TRACT.

ALL NATIVE GROWTH PROTECTION AREAS (NGPA) SHALL BE LEFT PERMANENTLY UNDISTURBED IN A SUBSTANTIALLY NATURAL STATE. NO CLEARING, GRADING, FILLING, BUILDING CONSTRUCTION OR PLACEMENT, OR ROAD CONSTRUCTION OF ANY KIND SHALL OCCUR, EXCEPT REMOVAL OF HAZARDOUS TREES WHEN APPROVED BY THE CITY. ACTIVITIES AS SET FORTH IN CHAPTER 22E.010 MMC ARE ALLOWED WHEN APPROVED BY THE CITY.

TRACT 999 IS RESERVED FOR FUTURE DEVELOPMENT.

IN WITNESS WHEREOF WE SET OUR HANDS AND SEALS THIS ___ DAY OF _____, 20___.

BY: ALLEN CREEK PARK, LLC, A WASHINGTON LIMITED LIABILITY COMPANY

BY: SPRINGLINE CAPITAL, LLC

ACKNOWLEDGMENTS

STATE OF WASHINGTON)
) SS.
COUNTY OF SNOHOMISH)

I CERTIFY THAT I KNOW OR HAVE SATISFACTORY EVIDENCE THAT _____ IS/ARE THE PERSON(S) WHO APPEARED BEFORE ME, AND SAID PERSON ACKNOWLEDGED THAT HE/SHE/THEY SIGNED THIS INSTRUMENT, ON OATH STATED THAT HE/SHE/THEY WAS/WERE AUTHORIZED TO EXECUTE THE INSTRUMENT AND ACKNOWLEDGED IT AS THE _____ OF ALLEN CREEK PARK, LLC, A WASHINGTON LIMITED LIABILITY COMPANY TO BE THE FREE AND VOLUNTARY ACT OF SUCH PARTY FOR THE USES AND PURPOSES MENTIONED IN THE INSTRUMENT.

DATED THIS _____ DAY OF _____, 201____.

(LEGIBLY PRINT NAME OF NOTARY)
NOTARY PUBLIC IN AND FOR THE STATE OF
WASHINGTON, RESIDING AT _____ MY COMMISSION EXPIRES _____

STATE OF WASHINGTON)
) SS.
COUNTY OF SNOHOMISH)

I CERTIFY THAT I KNOW OR HAVE SATISFACTORY EVIDENCE THAT _____ IS/ARE THE PERSON(S) WHO APPEARED BEFORE ME, AND SAID PERSON ACKNOWLEDGED THAT HE/SHE/THEY SIGNED THIS INSTRUMENT, ON OATH STATED THAT HE/SHE/THEY WAS/WERE AUTHORIZED TO EXECUTE THE INSTRUMENT AND ACKNOWLEDGED IT AS THE _____ OF SPRINGLINE CAPITAL, LLC TO BE THE FREE AND VOLUNTARY ACT OF SUCH PARTY FOR THE USES AND PURPOSES MENTIONED IN THE INSTRUMENT.

DATED THIS _____ DAY OF _____, 201____.

(LEGIBLY PRINT NAME OF NOTARY)
NOTARY PUBLIC IN AND FOR THE STATE OF
WASHINGTON, RESIDING AT _____ MY COMMISSION EXPIRES _____

LEGAL DESCRIPTION:

(PER CHICAGO TITLE INSURANCE COMPANY TITLE INSURANCE CERTIFICATE NO. 500002833C DATED DECEMBER 16, 2014)

PARCEL A:

PARCEL 2 OF SNOHOMISH COUNTY BOUNDARY LINE ADJUSTMENT NO. 04-119115 RECORDED UNDER RECORDING NO. 200703160044, BEING A PORTION OF THE NORTHEAST QUARTER OF THE SOUTHWEST QUARTER OF SECTION 22, TOWNSHIP 30 NORTH, RANGE 5 EAST OF THE WILLAMETTE MERIDIAN, AND A PORTION OF LOT 6, BLOCK 1, KELLOGG MARSH FIVE ACRE TRACTS, ACCORDING TO THE PLAT THEREOF RECORDED IN VOLUME 10 OF PLATS, PAGE 16 RECORDS OF SNOHOMISH COUNTY, WASHINGTON.

PARCEL B:

THE SOUTH HALF OF THE NORTHEAST QUARTER OF THE NORTHEAST QUARTER OF THE SOUTHWEST QUARTER OF SECTION 22, TOWNSHIP 30 NORTH, RANGE 5 EAST OF THE WILLAMETTE MERIDIAN,

SITUATE IN THE COUNTY OF SNOHOMISH, STATE OF WASHINGTON

CITY OF MARYSVILLE APPROVALS

CITY ENGINEER

EXAMINED AND APPROVED THIS _____ DAY OF _____, 20____.

CITY ENGINEER

DEPARTMENT OF COMMUNITY DEVELOPMENT

EXAMINED AND APPROVED THIS _____ DAY OF _____, 20____.

COMMUNITY DEVELOPMENT DIRECTOR

CITY MAYOR

EXAMINED, FOUND TO BE IN CONFORMITY WITH APPLICABLE ZONING AND OTHER LAND USE CONTROLS AND APPROVED THIS _____ DAY OF _____, 20____.

MAYOR, CITY OF MARYSVILLE

CITY CLERK

SNOHOMISH COUNTY APPROVALS

TREASURER'S CERTIFICATE

I HEREBY CERTIFY THAT ALL STATE AND COUNTY TAXES HERETOFORE LEVIED AGAINST THE PROPERTY DESCRIBED HEREIN, ACCORDING TO THE BOOKS AND RECORDS OF MY OFFICE, HAVE BEEN FULLY PAID AND DISCHARGED, INCLUDING _____ TAXES.

TREASURER, SNOHOMISH COUNTY _____ DATE _____

BY: DEPUTY COUNTY TREASURER _____ DATE _____

AUDITOR'S CERTIFICATE

RECORDING NO. _____

FILED FOR RECORD AT THE REQUEST OF THE MEAD GILMAN AND ASSOCIATES THIS _____ DAY OF _____, 20____, AT _____ MINUTES PAST _____ M. AND RECORDED IN VOLUME _____ OF PLATS, PAGES _____ THROUGH _____, RECORDS OF SNOHOMISH COUNTY, WASHINGTON.

AUDITOR, SNOHOMISH COUNTY _____

BY: DEPUTY COUNTY AUDITOR _____

LAND SURVEYOR'S CERTIFICATE

I HEREBY CERTIFY THAT THIS PLAT OF ALLEN CREEK PARK IS BASED UPON AN ACTUAL SURVEY AND SUBDIVISION OF THE SOUTHWEST AND SOUTHEAST QUARTERS OF SECTION 22, TOWNSHIP 30 NORTH, RANGE 5 EAST, W.M. AS REQUIRED BY STATE STATUTES; THAT ALL COURSES, DISTANCES AND ANGLES ARE SHOWN CORRECTLY THEREON; THAT THE MONUMENTS HAVE BEEN SET AND THE LOT AND BLOCK CORNERS HAVE BEEN STAKED CORRECTLY ON THE GROUND AND THAT I HAVE FULLY COMPLIED WITH THE PROVISIONS OF THE PLATTING REGULATIONS.

Ed Anderson

EDWARD D. ANDERSON
PROFESSIONAL LAND SURVEYOR
CERTIFICATE NO. 32434

9/1/2015

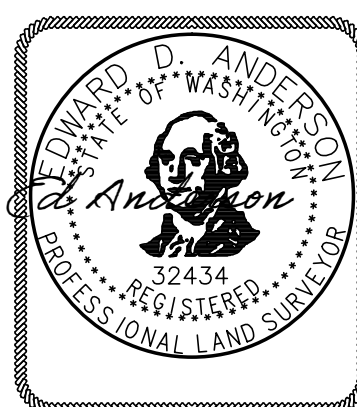

JOB NO. 14139
SHEET 1 OF 6

PLAT OF: ALLEN CREEK PARK		AREA: 11.21± ACRES
NE 1/4, SW 1/4 & NW 1/4, SE 1/4, SEC. 22, TWP. 30N., RGE. 5E., W.M. CITY OF MARYSVILLE, SNOHOMISH COUNTY WASHINGTON		TOTAL LOTS: 32
PARCEL NOS.: 30052200300200 & 30052200300300		TOTAL TRACTS: 5
		DATE: 03, FEB. 2015



Mead Gilman & Assoc.
Professional Land Surveyors

P.O. BOX 289, WOODINVILLE, WA 98072
PHONE: (425) 486-1252 FAX: (425) 486-6108

VOL/Pg

VOL/Pg

ALLEN CREEK PARK

NE 1/4, SW 1/4, SEC. 22, AND NW 1/4, SE 1/4, SEC. 22, T. 30 N., R. 5 E., W.M.
CITY OF MARYSVILLE, SNOHOMISH COUNTY, WASHINGTON (PFN. 04-119115-SD)

RESTRICTIONS

- SUBJECT TO THE ELECTRIC TRANSMISSION AND DISTRIBUTION LINE EASEMENT AND RIGHTS INCIDENTAL THERETO, AS GRANTED IN DOCUMENT TO PUGET SOUND POWER & LIGHT COMPANY AS RECORDED UNDER RECORDING NO. 491860.(BLANKED EASEMENT OVER N1/2 OF NE1/4 OF NE1/4 OF SW1/4 SEC 22-30N-R5E BEING PORTION OF PARCEL A)(NOT PLOTTABLE).
- SUBJECT TO CONTRACT OF RECOVERY OF UTILITY CONSTRUCTION COST AS RECORDED UNDER RECORDING NO. 20043261084. (NOT PLOTTABLE).
- SUBJECT TO COVENANTS, CONDITIONS, RESTRICTIONS, RECITALS, RESERVATIONS, EASEMENTS, EASEMENT PROVISIONS, DEDICATIONS, BUILDING SETBACK LINES, NOTES AND STATEMENTS, IF ANY, BUT OMITTING ANY COVENANTS OR RESTRICTIONS, IF ANY, INCLUDING BUT NOT LIMITED TO THOSE BASED UPON RACE, COLOR, RELIGION, SEX, SEXUAL ORIENTATION, FAMILIAL STATUS, MARITAL STATUS, DISABILITY, HANDICAP, NATIONAL ORIGIN, ANCESTRY, OR SOURCE OF INCOME, AS SET FORTH IN APPLICABLE STATE OR FEDERAL LAWS, EXCEPT TO THE EXTENT THAT SAID COVENANT OR RESTRICTION IS PERMITTED BY APPLICABLE LAW, AS SET FORTH ON BOUNDARY LINE ADJUSTMENT NO. 04-11915 AS RECORDED UNDER RECORDING NO. 200703160044.(NO EASEMENT SHOWN OR DESCRIBED ON SAID DOCUMENT)(NOTHING TO PLOT).
- SUBJECT TO ROAD EASEMENT AND THE RIGHT INCIDENTAL THERETO, AS GRANTED IN DOCUMENT TO JACK STRETCH AND FLORENCE STRETCH AS RECORDED UNDER RECORDING NO. 480097. (SAID EASEMENT FALLS IN DEDICATED BY THIS PLAT ROW OF 59TH AVE NE).(PLOTTED HEREON).
- SUBJECT TO THE ELECTRIC TRANSMISSION AND DISTRIBUTION LINE EASEMENT AND RIGHTS INCIDENTAL THERETO AS GRANTED IN DOCUMENT TO PUGET SOUND POWER & LIGHT COMPANY AS RECORDED UNDER RECORDING NO. 491859. (BLANKED EASEMENT OVER S1/2 OF NE1/4 OF NE1/4 OF SW1/4 SEC 22-30N-R5E - PARCEL B)(NOT PLOTTABLE).
- SUBJECT TO THE WATER LINE EASEMENT AND THE RIGHT INCIDENTAL THERETO, AS GRANTED IN A DOCUMENT TO CITY OF MARYSVILLE AS RECORDED UNDER RECORDING NO. 1952421.(PLOTTED HEREON).
- SUBJECT TO A DEED OF TRUST AS RECORDED UNDER RECORDING NO. 201411120916.(NOT PLOTTABLE).
- SUBJECT TO A DEED OF TRUST AS RECORDED UNDER RECORDING NO. 201412180364.(NOT PLOTTABLE)
- THE LOTS WITHIN THIS SUBDIVISION WILL BE SUBJECT TO SCHOOL IMPACT MITIGATION FEES FOR THE MARYSVILLE SCHOOL DISTRICT NO. 25 TO BE DETERMINED BY THE CERTIFIED AMOUNT WITHIN THE BASE FEE SCHEDULE IN EFFECT AT THE TIME OF BUILDING PERMIT APPLICATION, AND TO BE COLLECTED PRIOR TO BUILDING PERMIT ISSUANCE, IN ACCORDANCE WITH THE PROVISIONS OF CHAPTER 22D.010 MMC. CREDIT SHALL BE GIVEN FOR THREE EXISTING RESIDENTIAL UNITS. LOTS 1, 2 AND 3 SHALL RECEIVE CREDIT.
- CHAPTER 30.66 SCC REQUIRES THE NEW LOT MITIGATION PAYMENTS IN THE AMOUNTS SHOWN BELOW FOR EACH SINGLE-FAMILY RESIDENTIAL BUILDING PRIOR TO PERMIT ISSUANCE:
\$335.21 PER LOT FOR MITIGATION OF IMPACTS TO STATE HIGHWAYS,
\$3,025.65 PER LOT FOR MITIGATION OF IMPACTS ON THE CITY OF MARYSVILLE STREETS PAID TO THE CITY; AND
\$204.01 PER LOT FOR MITIGATION OF IMPACTS ON THE CITY OF ARLINGTON STREETS PAID TO THE CITY; AND THE DEVELOPER OF THIS SUBDIVISION HAS ELECTED TO DEFER THESE PAYMENT OBLIGATIONS TO A TIME PRECEDING BUILDING PERMIT ISSUANCE. NOTICE OF THESE MITIGATION PAYMENT OBLIGATIONS SHALL BE CONTAINED IN ANY DEEDS INVOLVING THIS SUBDIVISION OR THE LOTS THEREIN. ONCE A BUILDING PERMIT HAS BEEN ISSUED ALL MITIGATION PAYMENTS FOR THAT LOT SHALL BE DEEMED PAID.
- \$106,000.00 TO BE PAID TO THE MARYSVILLE SCHOOL DISTRICT FOR A SCHOOL BUS. ANY MONEYS LEFT AFTER PURCHASE OF THE BUS IS TO STAY WITH THE SCHOOL DISTRICT FOR MAINTENANCE.
- PARK MITIGATION SHALL BE PAID TO THE CITY OF MARYSVILLE IN THE AMOUNT OF \$1,040 PER LOT FOR MITIGATION OF IMPACTS ON MARYSVILLE PARKS PRIOR TO BUILDING PERMIT ISSUANCE.
- ON LOTS WITH MORE THAN ONE ROAD FRONTAGE CITY ENGINEERING DESIGN AND DEVELOPMENT STANDARDS (EDDS) RESTRICT LOT ACCESS TO THE MINOR ROAD, UNLESS THE DEPARTMENT OF PUBLIC WORKS GRANTS A FORMAL DEVIATION.
- ALL NATIVE GROWTH PROTECTION AREAS SHALL BE LEFT PERMANENTLY UNDISTURBED IN A SUBSTANTIALLY NATURAL STATE. NO CLEARING, GRADING, FILLING, BUILDING CONSTRUCTION OR PLACEMENT, OR ROAD CONSTRUCTION OF ANY KIND SHALL OCCUR, EXCEPT REMOVAL OF HAZARDOUS TREES. THE ACTIVITIES AS SET FORTH IN CHAPTER 22E.010 MMC ARE ALLOWED WHEN APPROVED BY THE CITY.
- ALL OPEN SPACE SHALL BE PROTECTED AS OPEN SPACE PERPETUITY. USE OF OPEN SPACE TRACTS WITHIN THIS SUBDIVISION IS RESTRICTED TO THOSE USES APPROVED FOR THE PLANNED RESIDENTIAL DEVELOPMENT, TO INCLUDE OPEN PLAY AREA, PICNIC AREAS, RECREATION TRAIL SYSTEM, VIEWING PLATFORM, DRAINAGE FACILITIES, BENCHES AND REQUIRED LANDSCAPE IMPROVEMENTS AS SHOWN ON THE APPROVED SITE PLAN AND THE APPROVED LANDSCAPE PLAN. COVENANTS, CONDITIONS AND RESTRICTIONS AS RECORDED WITH THE PLAT, AND AS MAY BE AMENDED IN THE FUTURE, SHALL INCLUDE PROVISIONS FOR THE CONTINUING PRESERVATION AND MAINTENANCE OF THE USES, FACILITY AND LANDSCAPING WITHIN THE OPEN SPACE AS APPROVED AND CONSTRUCTED.
- NO FURTHER SUBDIVISION OF ANY LOT WITHOUT RESUBMITTING FOR FORMAL PLAT PROCEDURE.
- THE SALE OR LEASE OF LESS THAN A WHOLE LOT IN ANY SUBDIVISION PLATTED AND FILED UNDER TITLE 22 OF THE MARYSVILLE MUNICIPAL CODE IS EXPRESSLY PROHIBITED EXCEPT IN COMPLIANCE WITH TITLE 22 OF THE MARYSVILLE MUNICIPAL CODE.
- ALL LANDSCAPED AREAS IN PUBLIC RIGHTS-OF-WAY SHALL BE MAINTAINED BY THE DEVELOPER AND HIS SUCCESSOR(S) AND MAY BE REDUCED OR ELIMINATED IF DEEMED NECESSARY FOR OR DETRIMENTAL TO CITY ROAD PURPOSES.
- THE LOCATION AND HEIGHT OF ALL FENCES AND OTHER OBSTRUCTIONS WITHIN AN EASEMENT AS DEDICATED ON THIS PLAT SHALL BE SUBJECT TO THE APPROVAL OF THE DIRECTOR OF PUBLIC WORKS OR HIS DESIGNEE.
- AN EASEMENT IS HEREBY GRANTED AND CONVEYED TO THE CITY OF MARYSVILLE, FRONTIER COMMUNICATIONS, COMCAST, CENTURY LINK/QWEST, PUGET SOUND ENERGY, THE OWNERS OF THE LOTS WITHIN THIS PLAT AND THEIR RESPECTIVE SUCCESSORS AND ASSIGNS, UNDER AND UPON THE EXTERIOR 10 FEET PARALLEL WITH AND ADJOINING THE STREET FRONTAGE OF ALL LOTS IN WHICH TO INSTALL, LAY, CONSTRUCT, RENEW, OPERATE AND MAINTAIN UNDERGROUND CONDUITS, CABLES, PIPE, AND WIRES WITH THE NECESSARY FACILITIES AND OTHER EQUIPMENT FOR THE PURPOSE OF SERVICE TO THIS SUBDIVISION AND OTHER PROPERTY WITH WATER, STORM DRAINAGE, ELECTRIC, TELEPHONE, GAS, TELEVISION, CABLE OR INTERNET SERVICE AND SEWER TOGETHER WITH THE RIGHT TO ENTER UPON THE EASEMENTS AT ALL TIMES FOR THE PURPOSES STATED. THESE EASEMENTS ENTERED UPON FOR THESE PURPOSES SHALL BE RESTORED AS NEAR AS POSSIBLE TO THEIR ORIGINAL CONDITION OF UTILITY. NO LINES OR WIRES FOR THE TRANSMISSION OF ELECTRIC CURRENT, TELEPHONE OR CABLE TV SHALL BE PLACED OR BE PERMITTED TO BE PLACED UPON ANY LOT UNLESS THE SAME SHALL BE UNDERGROUND OR IN CONDUIT ATTACHED TO A BUILDING.
- PRIVATE LANDSCAPE EASEMENT AS DEPICTED HEREIN FOR PURPOSE OF LANDSCAPING OVER LOTS 1-3, 7-11 AND 28-32 FOR BENEFIT OF ALL LOTS WITHIN THIS SUBDIVISION. THE RESPONSIBILITY OF AND THE COSTS FOR THE MAINTENANCE, WITHIN SAID PRIVATE EASEMENT SHALL BE BORNE IN EQUAL PARTS BY THE ALL LOT OWNERS WITHIN THIS SUBDIVISION.
- PRIVATE TEMPORARY ACCESS EASEMENT AS DEPICTED HEREIN OVER LOT 32 FOR THE PURPOSE OF VEHICULAR INGRESS, EGRESS AND TURN AROUND. THE RESPONSIBILITY OF AND THE COSTS FOR THE MAINTENANCE, WITHIN SAID PRIVATE EASEMENT SHALL BE BORNE IN EQUAL PARTS BY THE ALL LOT OWNERS WITHIN THIS SUBDIVISION. THE EASEMENT SHALL BE TERMINATED UPON FUTURE DEVELOPMENT OF 59TH AVE NE TO SOUTH OF PROP LINE.
- PRIVATE STORM DRAINAGE EASEMENTS AS DEPICTED HEREIN ARE HEREBY GRANTED AND CONVEYED FOR THE BENEFIT OF INDIVIDUAL LOTS SPECIFIED HEREIN. THE RESPONSIBILITY OF AND THE COSTS FOR THE MAINTENANCE, REPAIR, AND/OR RECONSTRUCTION OF THE STORM SEWER AND APPURTENANCES LOCATED WITHIN SAID PRIVATE EASEMENTS SHALL BE BORNE IN EQUAL PARTS BY THOSE OWNERS BENEFITING FROM SAID EASEMENTS, EXCEPT THAT NO OWNER SHALL BE RESPONSIBLE FOR THE COST OF MAINTENANCE AND/OR REPAIR ABOVE THEIR POINT OF CONNECTION.
- PRIVATE WATER EASEMENT OVER LOT 28 AS DEPICTED HEREIN IS FOR THE BENEFIT OF LOTS 26 AND 27. THE RESPONSIBILITY OF AND THE COSTS FOR THE MAINTENANCE, REPAIR, AND/OR RECONSTRUCTION OF THE JOINT USE DRIVEWAY LOCATED WITHIN SAID PRIVATE EASEMENTS SHALL BE BORNE EQUALLY BY THOSE OWNERS BENEFITING FROM SAID SYSTEMS.
- SUBJECT TO THE DECLARATION OF COVENANTS, CONDITIONS AND RESTRICTIONS RECORDED UNDER AFN _____

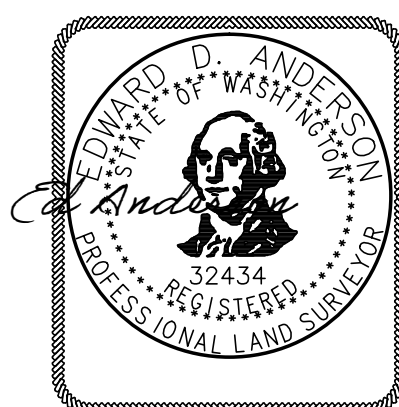
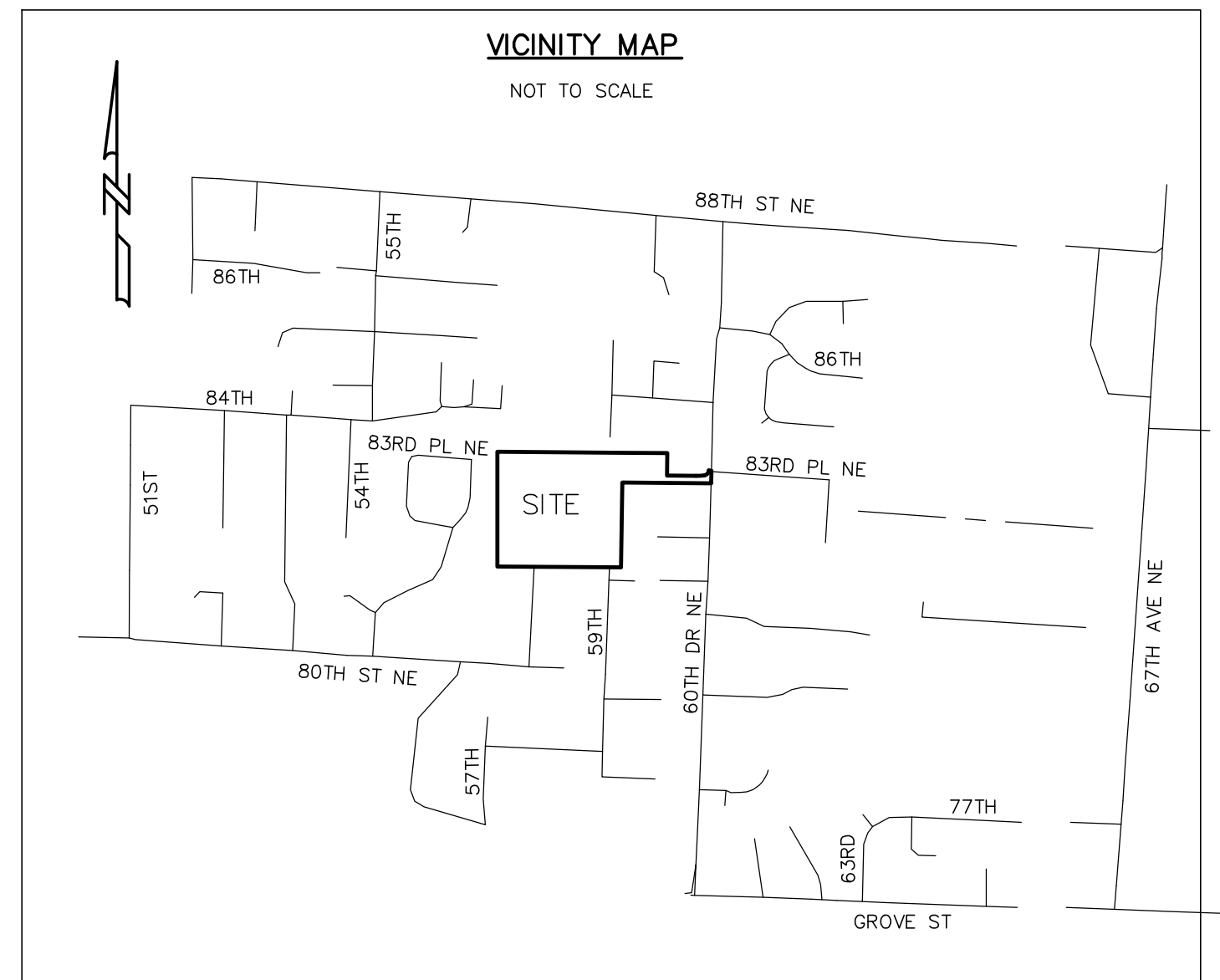

JOB NO. 14139
SHEET 2 OF 6

9/04/2015



Mead Gilman & Assoc.
Professional Land Surveyors

P.O. BOX 289, WOODINVILLE, WA 98072
PHONE: (425) 486-1252 FAX: (425) 486-6108

VOL/Pg

ALLEN CREEK PARK

NE 1/4, SW 1/4, SEC. 22, AND NW 1/4, SE 1/4, SEC. 22, T. 30 N., R. 5 E., W.M.
CITY OF MARYSVILLE, SNOHOMISH COUNTY, WASHINGTON (PFN. 04-119115-SD)

VOL/Pg

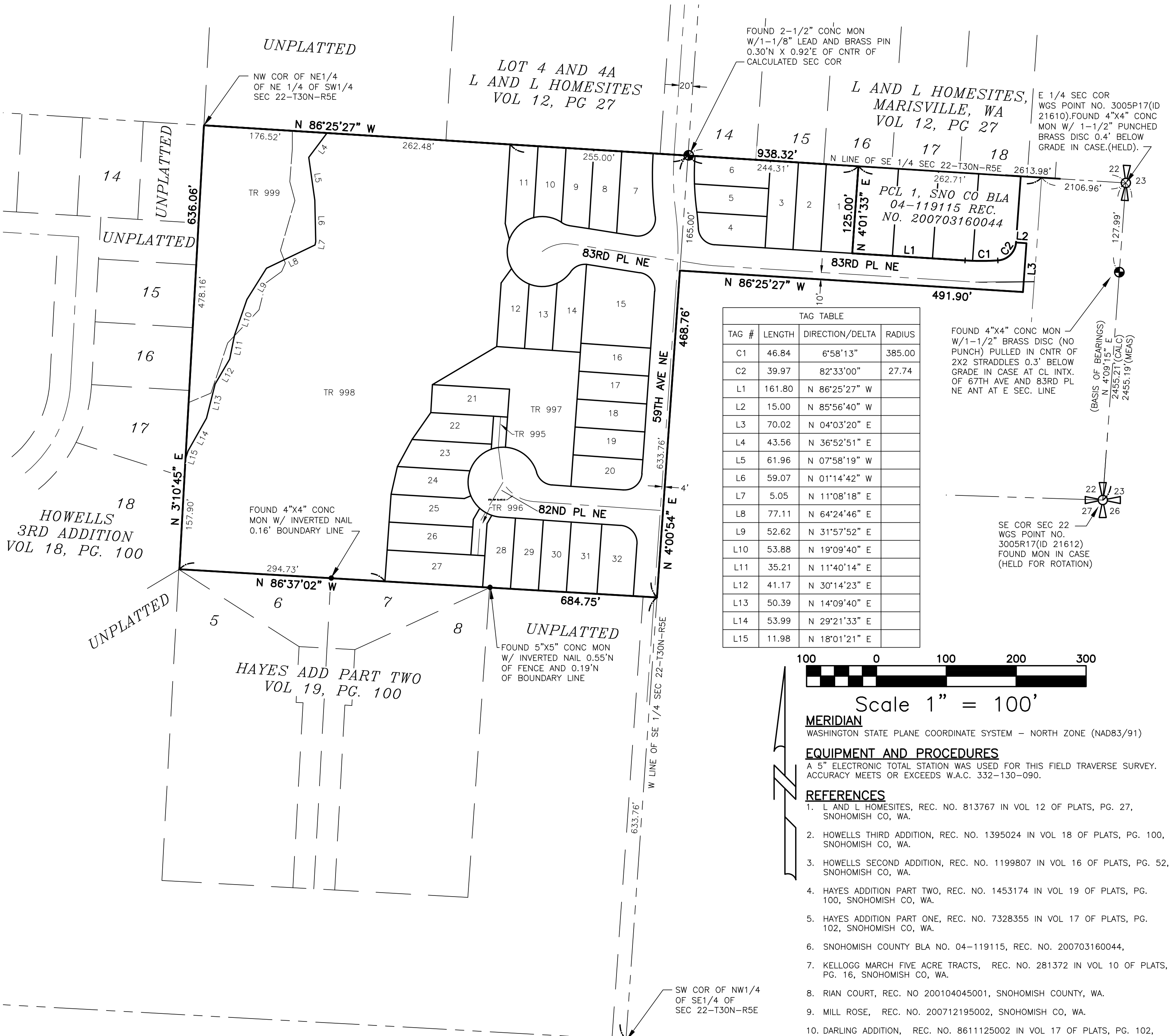

TAG #	LENGTH	DIRECTION/DELTA	RADIUS
C1	46.84	6°58'13"	385.00
C2	39.97	82°33'00"	27.74
L1	161.80	N 86°25'27" W	
L2	15.00	N 85°56'40" W	
L3	70.02	N 04°03'20" E	
L4	43.56	N 36°52'51" E	
L5	61.96	N 07°58'19" W	
L6	59.07	N 01°14'42" W	
L7	5.05	N 11°08'18" E	
L8	77.11	N 64°24'46" E	
L9	52.62	N 31°57'52" E	
L10	53.88	N 19°09'40" E	
L11	35.21	N 11°40'14" E	
L12	41.17	N 30°14'23" E	
L13	50.39	N 14°09'40" E	
L14	53.99	N 29°21'33" E	
L15	11.98	N 18°01'21" E	

FOUND 4"x4" CONC MON W/1-1/2" BRASS DISC (NO PUNCH) PULLED IN CNTR OF 2X2 STRADDLES 0.3' BELOW GRADE IN CASE AT CL INTX. OF 67TH AVE AND 83RD PL NE ANT AT E SEC. LINE

(BASIS OF BEARINGS)
N 4°09'15" E
2455.21' (CALC)
2455.19' (MEAS)

SE COR SEC 22
WGS POINT NO.
3005R17 (ID 21612)
FOUND MON IN CASE
(HELD FOR ROTATION)

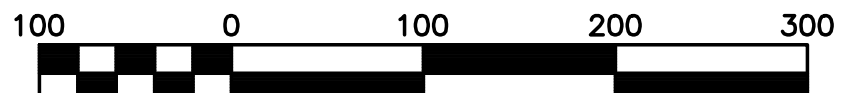

Scale 1" = 100'

MERIDIAN
WASHINGTON STATE PLANE COORDINATE SYSTEM - NORTH ZONE (NAD83/91)

EQUIPMENT AND PROCEDURES
A 5" ELECTRONIC TOTAL STATION WAS USED FOR THIS FIELD TRAVERSE SURVEY. ACCURACY MEETS OR EXCEEDS W.A.C. 332-130-090.

- REFERENCES**
- L AND L HOMESITES, REC. NO. 813767 IN VOL 12 OF PLATS, PG. 27, SNOHOMISH CO, WA.
 - HOWELLS THIRD ADDITION, REC. NO. 1395024 IN VOL 18 OF PLATS, PG. 100, SNOHOMISH CO, WA.
 - HOWELLS SECOND ADDITION, REC. NO. 1199807 IN VOL 16 OF PLATS, PG. 52, SNOHOMISH CO, WA.
 - HAYES ADDITION PART TWO, REC. NO. 1453174 IN VOL 19 OF PLATS, PG. 100, SNOHOMISH CO, WA.
 - HAYES ADDITION PART ONE, REC. NO. 7328355 IN VOL 17 OF PLATS, PG. 102, SNOHOMISH CO, WA.
 - SNOHOMISH COUNTY BLA NO. 04-119115, REC. NO. 200703160044,
 - KELLOGG MARCH FIVE ACRE TRACTS, REC. NO. 281372 IN VOL 10 OF PLATS, PG. 16, SNOHOMISH CO, WA.
 - RIAN COURT, REC. NO. 200104045001, SNOHOMISH COUNTY, WA.
 - MILL ROSE, REC. NO. 200712195002, SNOHOMISH CO, WA.
 - DARLING ADDITION, REC. NO. 8611125002 IN VOL 17 OF PLATS, PG. 102, SNOHOMISH CO, WA.
 - SP NO. ZA9309207SP, REC. NO. 9502225006, SNOHOMISH CO, WA.
 - CEDAR ON 60TH, PLANNED RESIDENTIAL DEVELOPMENT PFN 99-104515 SD, REC. NO. 200105305002, SNOHOMISH CO, WA.
 - JUBIE / BORSETH SP, REC. NO. 9607105001 IN VOL 3 OF SHORT PLATS, PGS. 73-75, SNOHOMISH CO, WA.
 - CEDAR CREST VISTA EASE DIV. 1, REC. NO. 9611145006, SNOHOMISH CO, WA.
 - CEDAR CREST VISTA EASE DIV. 2, REC. NO. 9704075003 IN VOL 63 OF PLATS, PG. 155, SNOHOMISH CO, WA.
 - HILTON'S NOMESITES, REC. NO. 1281499 IN VOL 17 OF PLATS, PG. 30, SNOHOMISH CO, WA.
 - HOMER B. HOWELL ADDITION, REC. NO. 7905090212 IN VOL 11 OF PLATS, PG. 257, SNOHOMISH CO, WA.

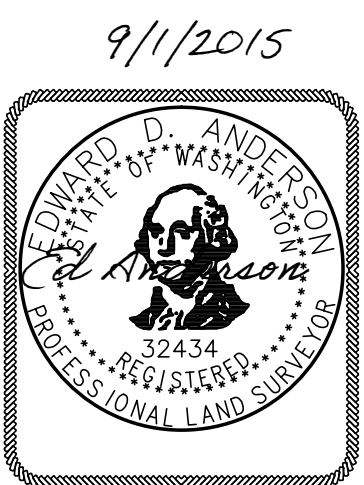
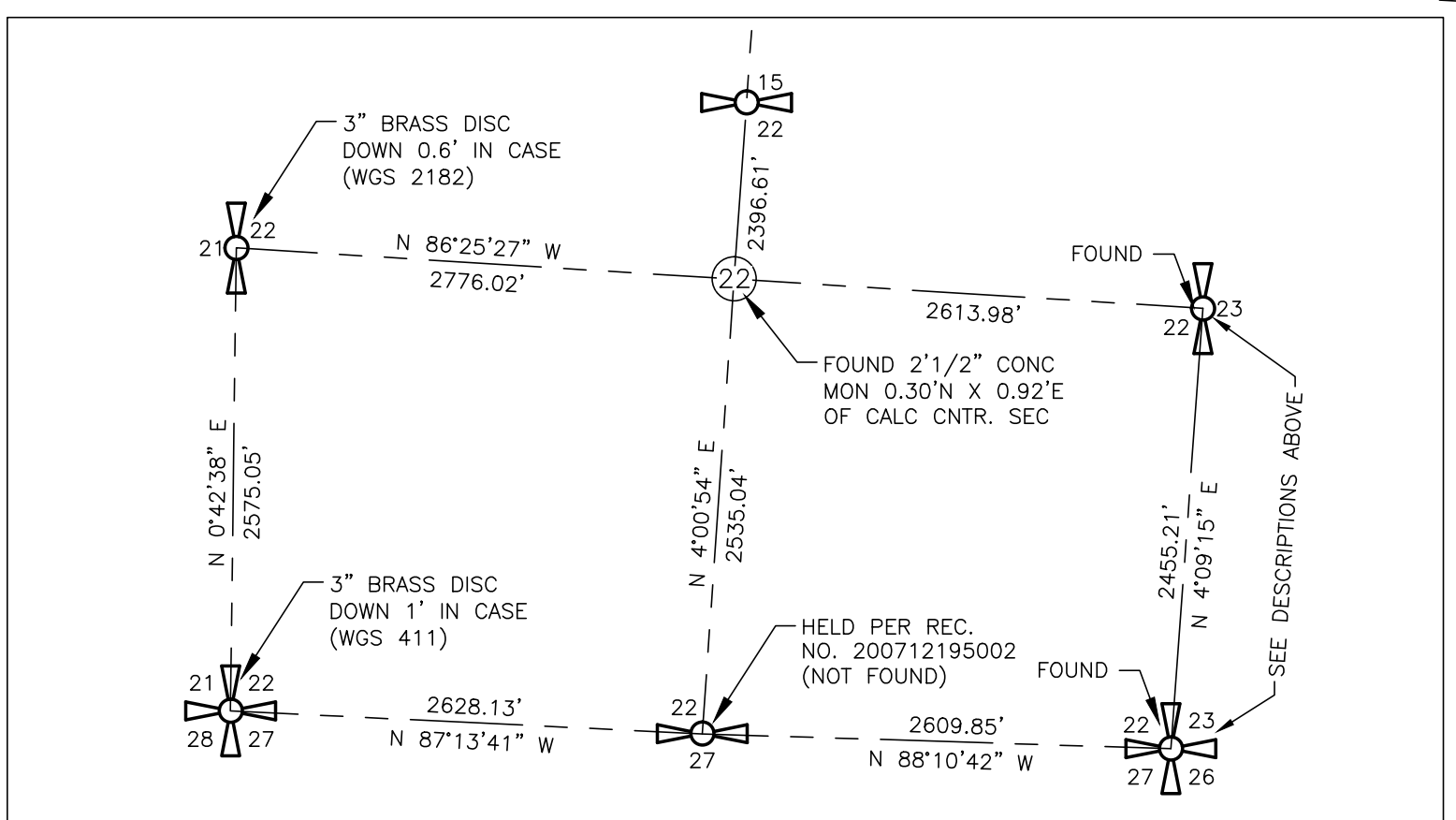

JOB NO. 14139
SHEET 3 OF 6



Mead Gilman & Assoc.
Professional Land Surveyors

P.O. BOX 289, WOODINVILLE, WA 98072
PHONE: (425) 486-1252 FAX: (425) 486-6108

VOL/Pg

ALLEN CREEK PARK

NE 1/4, SW 1/4, SEC. 22, AND NW 1/4, SE 1/4, SEC. 22, T. 30 N., R. 5 E., W.M.
CITY OF MARYSVILLE, SNOHOMISH COUNTY, WASHINGTON (PFN. 04-119115-SD)

TAG TABLE			
TAG #	LENGTH	DIRECTION/Delta	RADIUS
C14	48.60	55°41'45"	50.00
C16	34.11	39°05'34"	50.00
C17	41.37	47°24'15"	50.00
C18	25.65	29°23'52"	50.00
C19	26.05	59°41'35"	25.00
C20	1.73	3°57'59"	25.00
C21	37.15	85°07'52"	25.00
C22	39.27	90°00'00"	25.00
C23	30.42	69°42'59"	25.00
C24	60.84	69°42'59"	50.00
C25	44.95	51°30'36"	50.00
C26	36.53	41°51'43"	50.00
C27	22.22	25°27'31"	50.00
C28	12.67	14°31'02"	50.00
C29	39.27	90°00'00"	25.00
C30	20.14	23°04'26"	50.00
C31	20.58	23°34'41"	50.00
C32	27.78	63°39'34"	25.00
C36	4.55	26°03'16"	10.00
C37	11.36	1°34'08"	415.00
L2	23.81	N 14°25'28" W	
L3	10.00	N 67°03'54" E	
L4	18.32	N 30°04'09" E	
L5	13.70	N 30°04'09" E	
L6	20.00	N 86°37'02" W	
L7	40.00	N 04°00'54" E	
L8	43.40	N 04°00'54" E	
L9	20.00	N 86°37'02" W	
L10	25.54	N 35°51'52" E	
L23	7.36	N 04°00'54" E	
L24	47.36	N 04°00'54" E	
L25	44.30	N 04°00'54" E	
L26	46.21	N 04°00'54" E	

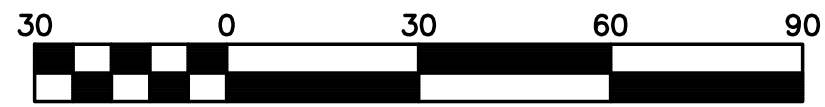

Scale 1" = 30'
MERIDIAN
WASHINGTON STATE PLANE COORDINATE SYSTEM - NORTH ZONE (NAD83/91)

EQUIPMENT AND PROCEDURES
A 5" ELECTRONIC TOTAL STATION WAS USED FOR THIS FIELD TRAVERSE SURVEY. ACCURACY MEETS OR EXCEEDS W.A.C. 332-130-090.

NOTES
ALL FRONT CORNERS ARE MARKED WITH A TACK AND LS WASHER STAMPED "32434" IN A LEAD PLUG AT THE PROPERTY LINE EXTENDED TO THE TOP OF CURB. REFER TO THE CURB PLUG TABLE ON SHEET 3 FOR DISTANCES FROM CURB PLUG TO FRONT PROPERTY CORNER.

- LEGEND**
- SET 1/2" X 24" REBAR WITH 1 3/4" PLASTIC CAP STAMPED "MEAD GILMAN & ASSOCIATES 32434/35145"
 - ⊕ SET 4" X 4" CONCRETE MONUMENT WITH 1 5/8" BRASS DISC WITH "X" STAMPED "32434" IN STANDARD KING COUNTY CASE. (UNLESS OTHERWISE NOTED)
 - BSBL BUILDING SETBACK LINE
 - F FRONTAGE BSBL (18' FOR GARAGE & 15' FOR HOUSE)
 - S 5' SIDE BSBL
 - R 5' REAR BSBL (INCREASED R BSBL FOR INFILTRATION TRENCHES AND STORM WATER EASEMENTS)

TR 998
194900 S.F.
(NGPA/OPEN SPACE)

TR 997
20701 S.F.
(OPEN SPACE AND DRAINAGE FACILITY)

TR 995
893 S.F.
(SHARED DRIVEWAY)

TR 996
1277 S.F.
(SHARED DRIVEWAY)

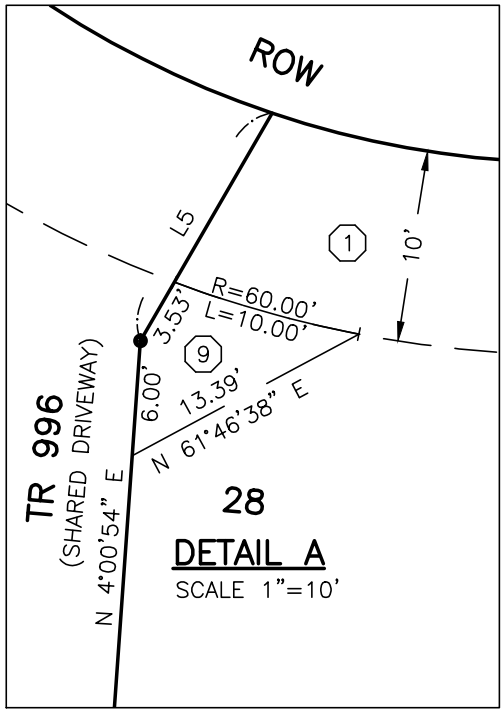

9/04/2015

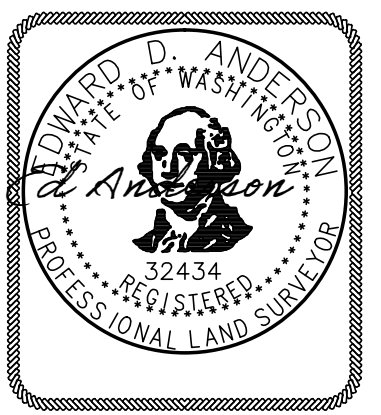

FOUND 4"x4" CONC MON W/ INVERTED NAIL 0.15" N OF N FACE BOARD FENCE AND 0.32" W OF N END SECOND BOARD FENCE

- EASEMENT LEGEND:**
- ① 10' UTILITY, WATER, SEWER, AND DRAINAGE EASEMENT. SEE RESTRICTION NOTE 20, SHEET 2.
 - ② 5' PRIVATE LANDSCAPE EASEMENT. FOR THE BENEFIT OF ALL LOTS. ALL LOTS SHALL SHARE MAINTENANCE RESPONSIBILITIES. SEE RESTRICTION NOTE 21, SHEET 2.
 - ③ 16' TEMPORARY PUBLIC TURNAROUND EASEMENT. ALL LOTS SHALL SHARE MAINTENANCE RESPONSIBILITIES. SEE RESTRICTION NOTE 22, SHEET 2.
 - ④ 10' PRIVATE DRAINAGE EASEMENT BENEFITING LOTS 26 AND 27. LOTS 26 AND 27 SHALL SHARE MAINTENANCE RESPONSIBILITIES. SEE RESTRICTION NOTE 23, SHEET 2.
 - ⑤ 10' PRIVATE DRAINAGE EASEMENT BENEFITING LOTS 21 AND 22. LOTS 21 AND 22 SHALL SHARE MAINTENANCE RESPONSIBILITIES. SEE RESTRICTION NOTE 23, SHEET 2.
 - ⑥ 10' PRIVATE STORM DRAINAGE EASEMENT BENEFITING LOTS 18 AND 19. LOTS 18 AND 19 SHALL SHARE MAINTENANCE RESPONSIBILITIES. SEE RESTRICTION NOTE 23, SHEET 2.
 - ⑦ 10' PRIVATE STORM DRAINAGE EASEMENT BENEFITING LOTS 15 AND 17. LOTS 15 AND 17 SHALL SHARE MAINTENANCE RESPONSIBILITIES. SEE RESTRICTION NOTE 23, SHEET 2.
 - ⑧ PRIVATE STORM DRAINAGE EASEMENT BENEFITING LOTS 12 AND 14. LOTS 12 AND 14 SHALL SHARE MAINTENANCE RESPONSIBILITIES. SEE RESTRICTION NOTE 23, SHEET 2.
 - ⑨ PRIVATE WATER EASEMENT BENEFITING LOTS 26 AND 27. LOTS 26 AND 27 SHALL SHARE MAINTENANCE RESPONSIBILITIES. SEE RESTRICTION NOTE 24, SHEET 2.

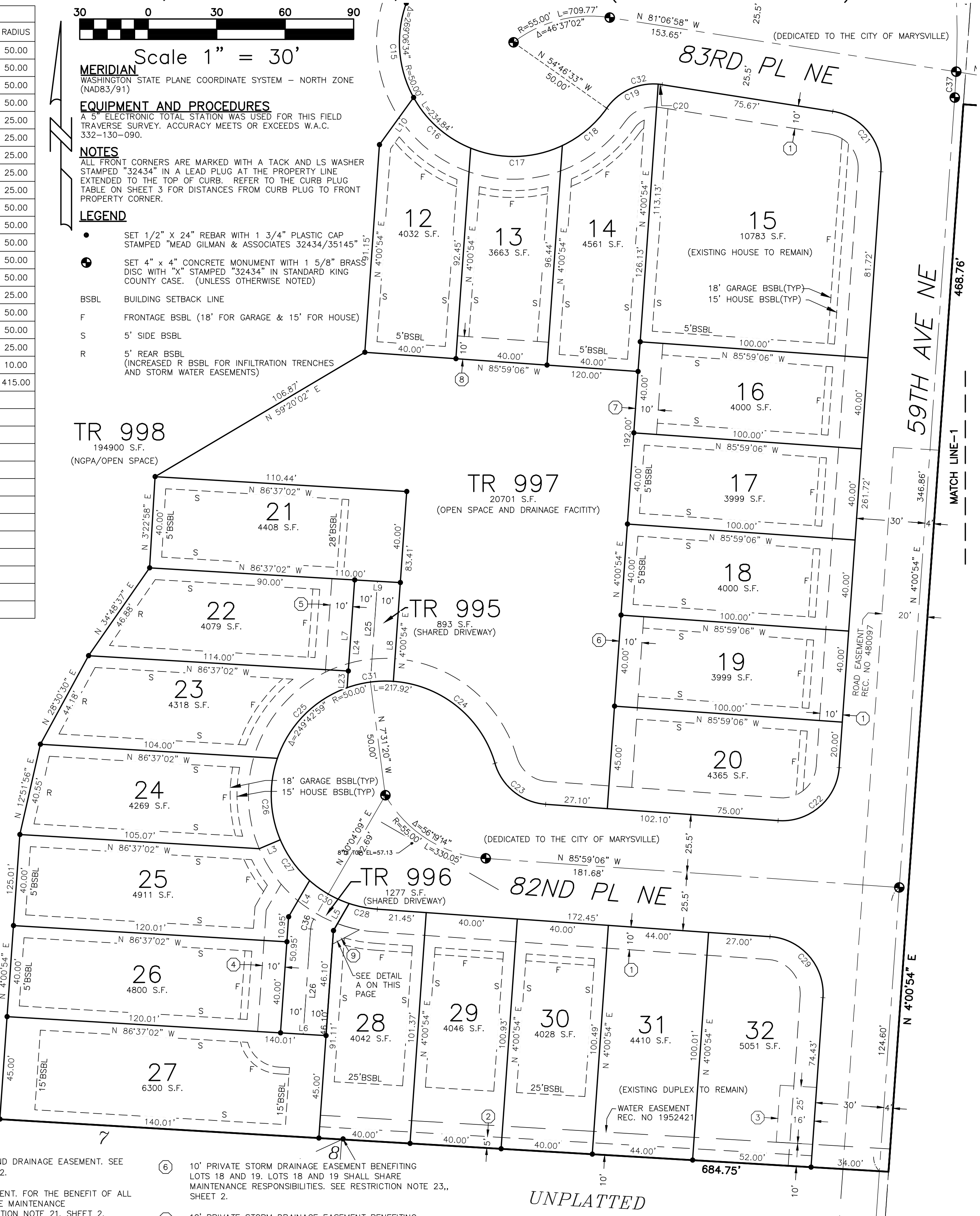

UNPLATTED

MG & A
Mead Gilman & Assoc.
Professional Land Surveyors
P.O. BOX 289, WOODINVILLE, WA 98072
PHONE: (425) 486-1252 FAX: (425) 486-6108

JOB NO. 14139
SHEET 4 OF 6

ALLEN CREEK PARK

NE 1/4, SW 1/4, SEC. 22, AND NW 1/4, SE 1/4, SEC. 22, T. 30 N., R. 5 E., W.M.
CITY OF MARYSVILLE, SNOHOMISH COUNTY, WASHINGTON (PFN. 04-119115-SD)

VOL/PG

TAG #	LENGTH	DIRECTION/DELTA	RADIUS
C3	36.12	82°46'25"	25.00
C4	23.42	3°00'55"	445.00
C5	4.56	0°35'15"	445.00
C6	35.89	5°20'29"	385.00
C7	40.06	5°57'40"	385.00
C8	87.29	11°14'19"	445.00
C9	3.37	0°30'03"	385.00
C10	46.09	105°38'11"	25.00
C11	11.10	25°27'00"	25.00
C12	1.01	1°09'37"	50.00
C13	41.38	47°25'18"	50.00

TAG #	LENGTH	DIRECTION/DELTA	RADIUS
C14	48.60	55°41'45"	50.00
C15	42.71	48°56'12"	50.00
C16	34.11	39°05'34"	50.00
C17	41.37	47°24'15"	50.00
C18	25.65	29°23'52"	50.00
C19	26.05	59°41'35"	25.00
C20	1.73	3°57'59"	25.00
C21	37.15	85°07'52"	25.00
C24	60.84	69°42'59"	50.00
C25	44.95	51°30'36"	50.00
C31	20.58	23°34'41"	50.00

TAG #	LENGTH	DIRECTION/DELTA	RADIUS
C32	27.78	63°39'34"	25.00
C33	27.98	3°36'10"	445.00
C35	15.29	5°18'29"	165.00
C37	11.36	1°34'08"	415.00
L2	23.81	N 14°25'28" W	
L7	40.00	N 04°00'54" E	
L8	43.40	N 04°00'54" E	
L9	20.00	N 86°37'02" W	
L10	25.54	N 35°51'52" E	
L23	7.36	N 04°00'54" E	
L24	47.36	N 04°00'54" E	

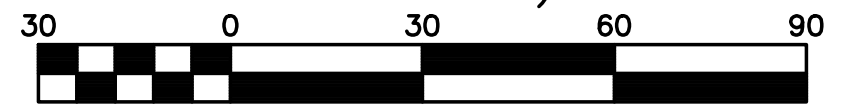

Scale 1" = 30'

MERIDIAN
WASHINGTON STATE PLANE COORDINATE SYSTEM - NORTH ZONE (NAD83/91)

EQUIPMENT AND PROCEDURES
A 5" ELECTRONIC TOTAL STATION WAS USED FOR THIS FIELD TRAVERSE SURVEY. ACCURACY MEETS OR EXCEEDS W.A.C. 332-130-090.

NOTES
ALL FRONT CORNERS ARE MARKED WITH A TACK AND LS WASHER STAMPED "32434" IN A LEAD PLUG AT THE PROPERTY LINE EXTENDED TO THE TOP OF CURB. REFER TO THE CURB PLUG TABLE ON SHEET 3 FOR DISTANCES FROM CURB PLUG TO FRONT PROPERTY CORNER.

LEGEND

- SET 1/2" X 24" REBAR WITH 1 3/4" PLASTIC CAP STAMPED "MEAD GILMAN & ASSOCIATES 32434/35145"
- ⊕ SET 4" X 4" CONCRETE MONUMENT WITH 1 5/8" BRASS DISC WITH "X" STAMPED "32434" IN STANDARD KING COUNTY CASE. (UNLESS OTHERWISE NOTED)
- BSBL BUILDING SETBACK LINE
- F FRONTAGE BSBL (18' FOR GARAGE & 15' FOR HOUSE)
- S 5' SIDE BSBL
- R 5' REAR BSBL (INCREASED R BSBL FOR INFILTRATION TRENCHES AND STORM WATER EASEMENTS)

L AND L HOMESITES
VOL 12, PG 27

FOUND 2-1/2" CONC MON
W/1-1/8" LEAD AND BRASS
PIN 0.5" N OF BOARD
FENCE TO E/W 0.30" N X
0.92" E OF CNTR SEC COR



EASEMENT LEGEND:

- ① 10' UTILITY, WATER, SEWER, AND DRAINAGE EASEMENT. SEE RESTRICTION NOTE 20, SHEET 2.
- ② 5' PRIVATE LANDSCAPE EASEMENT. FOR THE BENEFIT OF ALL LOTS. ALL LOTS SHALL SHARE MAINTENANCE RESPONSIBILITIES. SEE RESTRICTION NOTE 21, SHEET 2.
- ⑤ 10' PRIVATE DRAINAGE EASEMENT BENEFITING LOTS 21 AND 22. LOTS 21 AND 22 SHALL SHARE MAINTENANCE RESPONSIBILITIES. SEE RESTRICTION NOTE 23, SHEET 2.
- ⑥ 10' PRIVATE STORM DRAINAGE EASEMENT BENEFITING LOTS 18 AND 19. LOTS 18 AND 19 SHALL SHARE MAINTENANCE RESPONSIBILITIES. SEE RESTRICTION NOTE 23, SHEET 2.
- ⑦ 10' PRIVATE STORM DRAINAGE EASEMENT BENEFITING LOTS 15 AND 17. LOTS 15 AND 17 SHALL SHARE MAINTENANCE RESPONSIBILITIES. SEE RESTRICTION NOTE 23, SHEET 2.
- ⑧ PRIVATE STORM DRAINAGE EASEMENT BENEFITING LOTS 12 AND 14. LOTS 12 AND 14 SHALL SHARE MAINTENANCE RESPONSIBILITIES. SEE RESTRICTION NOTE 23, SHEET 2.

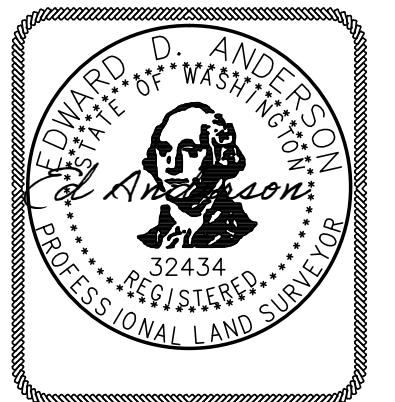

9/04/2015



Mead Gilman & Assoc.
Professional Land Surveyors

P.O. BOX 289, WOODINVILLE, WA 98072
PHONE: (425) 486-1252 FAX: (425) 486-6108

JOB NO. 14139
SHEET 5 OF 6

VOL/PG

ALLEN CREEK PARK

NE 1/4, SW 1/4, SEC. 22, AND NW 1/4, SE 1/4, SEC. 22, T. 30 N., R. 5 E., W.M.
CITY OF MARYSVILLE, SNOHOMISH COUNTY, WASHINGTON (PFN. 04-119115-SD)



Scale 1" = 30'

MERIDIAN

WASHINGTON STATE PLANE COORDINATE SYSTEM - NORTH ZONE (NAD83/91)

EQUIPMENT AND PROCEDURES

A 5" ELECTRONIC TOTAL STATION WAS USED FOR THIS FIELD TRAVERSE SURVEY. ACCURACY MEETS OR EXCEEDS W.A.C. 332-130-090.

NOTES

ALL FRONT CORNERS ARE MARKED WITH A TACK AND LS WASHER STAMPED "32434" IN A LEAD PLUG AT THE PROPERTY LINE EXTENDED TO THE TOP OF CURB. REFER TO THE CURB PLUG TABLE ON SHEET 3 FOR DISTANCES FROM CURB PLUG TO FRONT PROPERTY CORNER.

LEGEND

- SET 1/2" X 24" REBAR WITH 1 3/4" PLASTIC CAP STAMPED "MEAD GILMAN & ASSOCIATES 32434/35145"
- ⊙ SET 4" X 4" CONCRETE MONUMENT WITH 1 5/8" BRASS DISC WITH "X" STAMPED "32434" IN STANDARD KING COUNTY CASE. (UNLESS OTHERWISE NOTED)
- BSBL BUILDING SETBACK LINE
- F FRONTAGE BSBL (18' FOR GARAGE & 15' FOR HOUSE)
- S 5' SIDE BSBL
- R 5' REAR BSBL (INCREASED R BSBL FOR INFILTRATION TRENCHES AND STORM WATER EASEMENTS)

L AND L HOMESITES,
MARISVILLE, WA
VOL 12, PG 27
15

14

16

17

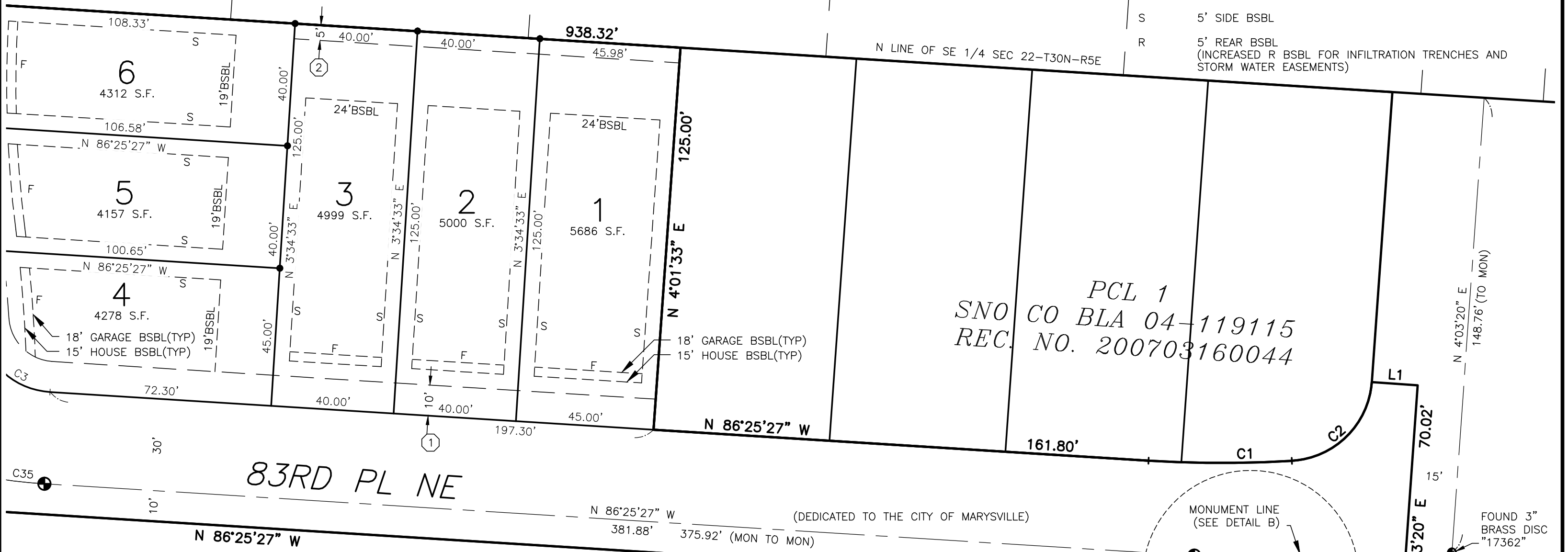

PCL 1
SNO CO BLA 04-119115
REC. NO. 200703160044

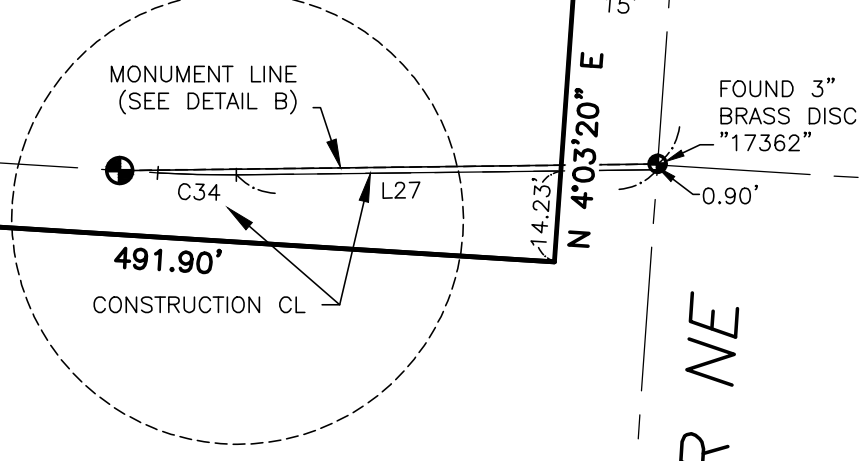

TAG TABLE			
TAG #	LENGTH	DIRECTION/Delta	RADIUS
C1	46.84	6°58'13"	385.00
C2	39.97	82°33'00"	27.74
C3	36.12	82°46'25"	25.00
C4	23.42	3°00'55"	445.00
C5	4.56	0°35'15"	445.00
C6	35.89	5°20'29"	385.00
C7	40.06	5°57'40"	385.00
C33	27.98	3°36'10"	445.00
C34	12.28	4°15'48"	165.00
C35	15.29	5°18'29"	165.00
C38	12.28	4°15'48"	165.00
L1	15.00	N 85°56'40" W	
L27	65.77	N 89°18'45" E	

CURB PLUG TABLES

LOT LINE	OFFSET (FT)
BNDRY/1	11.68
1/2	11.64
2/3	11.65
3/4	11.61
4/5	12.00
5/6	11.73
7/8	11.24
8/9	11.25
9/10	11.29
10/11	9.95
12/13	10.88
13/14	12.43
14/15	10.93
15/16	11.71
16/17	11.72
17/18	11.71
18/19	11.78
19/20	11.76
20/TR 997	11.25
TR997/TR995	9.19
TR 995/23	10.61
23/24	10.02
24/25	9.73
25/TR 996	9.11
TR 996/28	9.99
28/29	11.18
29/30	11.22
30/31	11.20
31/32	11.25

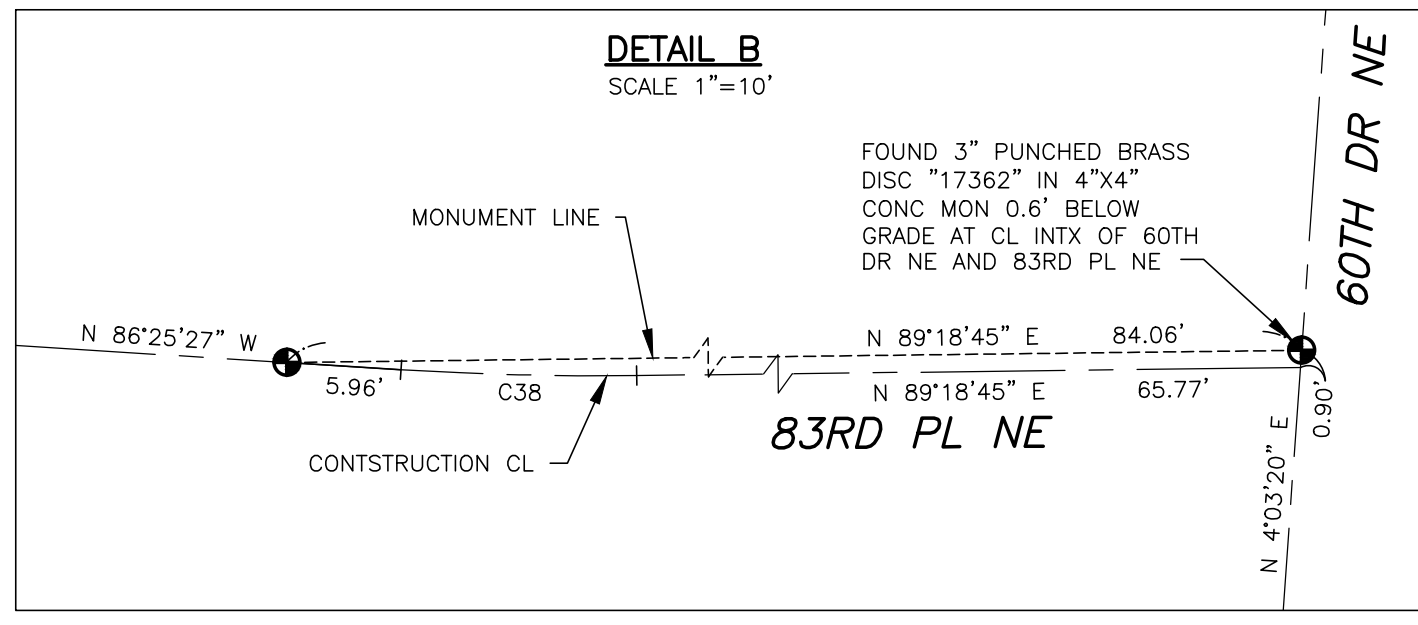

EASEMENT LEGEND:

- ① 10' UTILITY, WATER, SEWER, AND DRAINAGE EASEMENT. SEE RESTRICTION NOTE 20, SHEET 2.
- ② 5' PRIVATE LANDSCAPE EASEMENT. FOR THE BENEFIT OF ALL LOTS. ALL LOTS SHALL SHARE MAINTENANCE RESPONSIBILITIES. SEE RESTRICTION NOTE 21, SHEET 2.

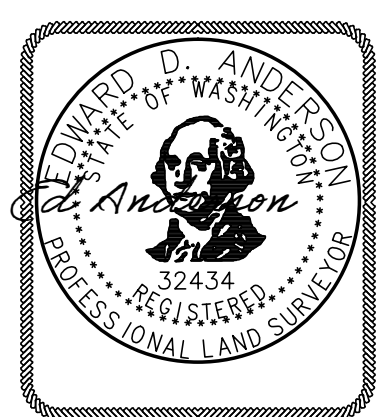

MG & A
Mead Gilman & Assoc.
Professional Land Surveyors
P.O. BOX 289, WOODINVILLE, WA 98072
PHONE: (425) 486-1252 FAX: (425) 486-6108

9/1/2015 JOB NO. 14139 SHEET 6 OF 6

VOL/PG



FINAL PLAT INTERNAL ROUTING CHECKLIST

Community Development Department ♦ 80 Columbia Avenue ♦ Marysville, WA 98270
 (360) 363-8100 ♦ (360) 651-5099 FAX ♦ Office Hours: Monday - Friday 7:30 AM - 4:00 PM

Plat Name: <u>Allen Creek Park</u>		PA # <u>PFN 04-119115</u>	
Item	Department	Initials	Date
1. Plat Map- Checked & Approved	Land Dev.	<u>DJ</u>	<u>4/8/15</u>
	Planning	<u>AA</u>	<u>9/15/15</u>
2. Letter of Segregation to Assessor	Planning	<u>AA</u>	<u>9/20/15</u>
3. Water System/Sewer System			
Letter of Acceptance	Const. Insp.	<u>SAS</u>	<u>9/29/15</u>
Asbuilts – Including Digital Files	Const. Insp.	<u>SAS</u>	<u>9/29/15</u>
Bill(s) of Sale	Const. Insp.	<u>SAS</u>	<u>9/29/15</u>
Maintenance and Warranty Funding	Const. Insp.	<u>SAS</u>	<u>9/29/15</u>
4. Road/Storm Sewer			
Letter of Acceptance	Const. Insp.	<u>SAS</u>	<u>9/29/15</u>
Asbuilts – Including Digital Files	Const. Insp.	<u>SAS</u>	<u>9/29/15</u>
Bill(s) of Sale	Const. Insp.	<u>SAS</u>	<u>9/29/15</u>
Maintenance and Warranty Funding	Const. Insp.	<u>SAS</u>	<u>9/29/15</u>
5. Performance Bond – Submitted/Approved			
(If Required - Road and Storm Drain Only)	Const. Insp.	<u>SAS</u>	<u>9/29/15</u>
6. Inspection Fees - Calculated and Paid	Const. Insp.	<u>SAS</u>	<u>9/29/15</u>
7. Final Plat Fee - Calculated and Paid	Planning	<u>AA</u>	<u>9/15/15</u>
8. TIP Fees: <u>3,564.87</u>	Planning	<u>AA</u>	<u>9/15/15</u>
9. Parks Mitigation Fees: <u>1,040.00</u>	Planning	<u>AA</u>	<u>9/15/15</u>
10. School District Mitigation Fees: _____	Planning	<u>AA</u>	<u>9/15/15</u>
<u>Fee @ time of bldg. permit submitted</u>			
11. Signage and Striping Installed	Const. Insp.	<u>SAS</u>	<u>9/29/15</u>

12. Final Grading and TESC Inspection	Const. Insp.	SAS	9/29/15
13. Satisfied Hearing Examiner's Conditions of Approval	Planning	AA	9/15/15
14. Utility/Recovery/Main Fees	Land Dev.	RJ	9/15/15

Plat Approved for Recording:

Community Development Director: 

Date: 9/30/2015

City Engineer: 

Date: 9/29/2015

Note: The final plat will not be scheduled before the City Council until this checklist is complete.

CITY OF MARYSVILLE

EXECUTIVE SUMMARY FOR ACTION

CITY COUNCIL MEETING DATE: October 12, 2015

AGENDA ITEM: Authorize the Mayor to sign the sight distance easement for Allen Creek Park Snohomish County: PFN 04119115	AGENDA SECTION:	
PREPARED BY: Amy Hess, Assistant Planner	APPROVED BY:	
ATTACHMENTS: 1. Sight Distance Easement		
	MAYOR	CAO
BUDGET CODE:	AMOUNT:	

DESCRIPTION:

During construction of the subdivision of Allen Creek Park, the applicant removed some trees on a neighboring parcel in order to install utilities. The adjacent property owner agreed to the tree removal, subject to installation of a quality 6’ wood fence along the perimeter of the property. Installation of the fence created a sight distance issue at the southeast corner of 59th Avenue NE and 83rd Place NE. The wood (opaque) fence was replaced with chain link (transparent) fencing in order to alleviate the sight distance issue. In order to ensure adequate sight distance at this intersection, the City required that the applicant record a sight distance easement which requires the property owner to maintain transparency at this intersection.

Staff is recommending approval of the Final Plat of Allen Creek concurrently with this sight distance easement.

RECOMMENDED ACTION: Staff recommends City Council authorize the Mayor to sign the sight distance easement associated with the Plat of Allen Creek Park.
COUNCIL ACTION:

AFTER RECORDING RETURN TO:

City of Marysville
 1049 State Ave
 Marysville WA 98270

**CITY OF MARYSVILLE
 SIGHT DISTANCE EASEMENT**

THIS EASEMENT made this 29th day of September, 2015, between MICHELE J PALM WESTON, hereinafter referred to as "Grantor," the CITY OF MARYSVILLE, a municipal corporation of the State of Washington, hereinafter referred to as "Grantee" or "City"

NOW, THEREFORE, Grantor, for valuable consideration, the adequacy and receipt of which is hereby acknowledged, hereby conveys and grants to the Grantee, its successors and assigns and its contractors, agents, permittees and licensees, the perpetual right, privilege and authority of a sight triangle easement

As described in attached exhibit "A" and depicted on attached exhibit "B".

The sight triangle easement is granted and conveyed for the purpose of providing clear and unobstructed views along the lanes of travel, at the intersection of 83rd Place NE and 59th Ave. NE.

The Grantor reserves the right to use the surface of the above-described easement as a yard but shall not erect any buildings, structures, patios, or other construction of any nature on said easement. Furthermore the Grantor shall be responsible for keeping all vegetation clear over said easement between 30 inches and 8 feet above the adjacent road grade.

The Grantee is also granted the right of ingress to and egress for the purpose of removing vegetation in the event of an emergency.

This conveyance shall be a covenant running with the land, and shall be binding on the Grantor and its heirs, successors and assigns forever.

Any mortgage on said land held by the Mortgagee is hereby subordinated to the rights herein granted to the Grantee, but in all other respects the said mortgage shall remain unimpaired.

IN WITNESS WHEREOF, this instrument has been executed the day and year first above written.

GRANTOR

Michele J. Smith

GRANTEE

INDIVIDUAL NOTARY:

STATE OF WASHINGTON)
) ss
COUNTY OF SNOHOMISH)

I certify that I know or have satisfactory evidence that Michele J. Smith is/are the person(s) who appeared before me, and said person(s) acknowledged that he/she/they signed this instrument and acknowledged it to be his/her/their free and voluntary act for the uses and purposes mentioned in the instrument.

DATED this 29th day of Sept. 2015



Sam A. Nouri

(Legibly print name of notary)
NOTARY PUBLIC in and for the State of
Washington, residing at WA
My commission expires: 04/03/16

REPRESENTATIVE NOTARY:

STATE OF WASHINGTON)
) ss
COUNTY OF SNOHOMISH)

I certify that I know or have satisfactory evidence that _____ is/are the person(s) who appeared before me, and said person(s) acknowledged that he/she/they signed this instrument , and on oath stated that he/she/they were authorized to execute the instrument and acknowledged it as the _____ of _____ to be the free and voluntary act of such party for the uses and purposes mentioned in the instrument.

DATED this _____ day of _____

(Legibly print name of notary)
NOTARY PUBLIC in and for the State of
Washington, residing at _____
My commission expires: _____

EXHIBIT A

THAT PORTION OF THE WEST 241.18 FEET OF LOT 6, BLOCK 1, KELLOGG MARSH FIVE ACRE TRACTS, ACCORDING TO THE PLAT THEREOF RECORDED IN VOLUME 10 OF PLATS, PAGE 16 RECORDS OF SNOHOMISH COUNTY, WASHINGTON;
EXCEPT THE NORTH 185.00 FEET THEREOF;
TOGETHER WITH THE SOUTH 20.00 FEET OF THE NORTH 185.00 FEET OF SAID LOT 6;
LYING NORTHWESTERLY OF THE FOLLOWING DESCRIBED LINE:

COMMENCING AT THE NORTHWEST CORNER OF DESCRIBED LAND AT THE SOUTH LINE OF THE NORTH 165 FEET OF SAID LOT 6 AND SAID CORNER BEING INTERNAL ANGLE POINT OF PARCEL 2 OF SNOHOMISH COUNTY BOUNDARY LINE ADJUSTMENT NO. 04-119115 AS RECORDED UNDER RECORDING NO. 200703160044; THENCE SOUTH 86°25'27" EAST ALONG SAID SOUTH LINE OF NORTH 165 FEET 18.13 FEET TO THE **TRUE POINT OF BEGINNING** OF DESCRIBED LINE; THENCE SOUTH 16°52'20" WEST 81.47 FEET TO THE WEST LINE OF SAID LOT 6 AND THE END OF THE DESCRIBED LINE.

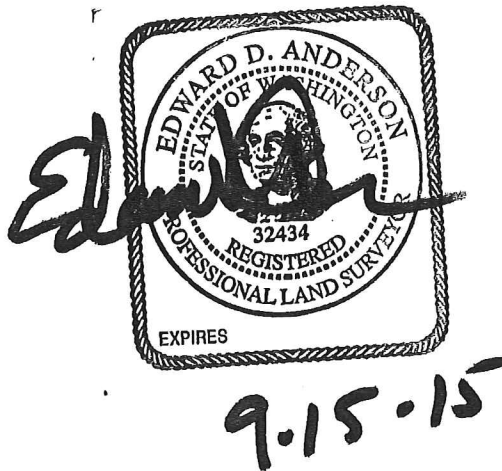

EXHIBIT B

PARCEL 2
BLA 04-119115

PARCEL 2
BLA 04-119115
REC. NO. 200703160044
(TAX. NO. 30052200300300)

W LINE LOT 6, KELLOG MARSH 5 AC TRACTS
N 4°00'54" E

W. LINE OF SE1/4 SEC 22-30-05

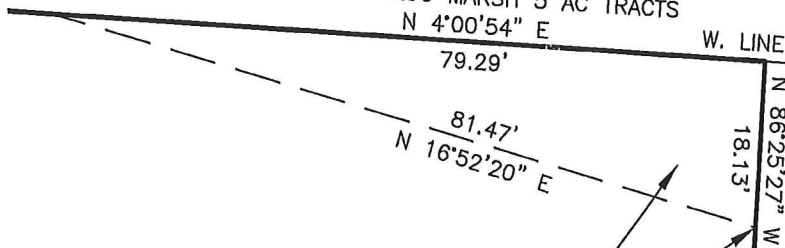

SITE DISTANCE
EASEMENT

T.P.O.B.

S. LINE OF N. 165 FEET OF LOT 6,
KELLOGG MARSH 5 AC TRACTS

PORTION OF TRACT 6,
KELLOGG MARCH FIVE
ACRE TRACTS
(TAX NO. 004800100602)

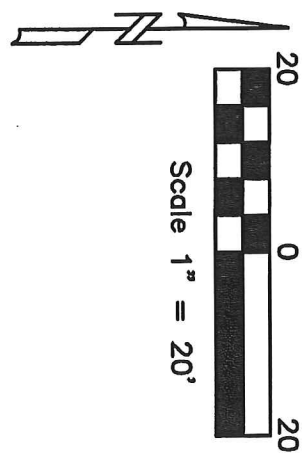

9.15.15



NW1/4, SE1/4, SEC. 22, T. 30 N., R. 5 E., W.M.



Mead Gilman & Assoc.
Professional Land Surveyors
P.O. BOX 289, WOODINVILLE, WA 98072
PHONE: (425) 486-1252 FAX: (425) 486-6108

JOB NO. 14139

Update
Index #13

CITY OF MARYSVILLE

EXECUTIVE SUMMARY FOR ACTION

CITY COUNCIL MEETING DATE: October 12, 2015

AGENDA ITEM: Payroll	AGENDA SECTION:	
PREPARED BY: Sandy Langdon, Finance Director	AGENDA NUMBER:	
ATTACHMENTS: Blanket Certification	APPROVED BY:	
	MAYOR	CAO
BUDGET CODE:	AMOUNT:	

RECOMMENDED ACTION:

The Finance and Executive Departments recommend City Council approve the October 5, 2015 payroll in the amount \$1,625,588.74 Check No.'s 29307 through 29340.

COUNCIL ACTION:

Index #5

CITY OF MARYSVILLE AGENDA BILL

EXECUTIVE SUMMARY FOR ACTION

CITY COUNCIL MEETING DATE: 10/12/2015

AGENDA ITEM: Accept JAG GRANT FUNDING	
PREPARED BY: Chief Richard Smith	DIRECTOR APPROVAL: 
DEPARTMENT: Police	
ATTACHMENTS: Yes	
BUDGET CODE: 00103 010.549000 - 91501	AMOUNT: \$11,410.00

SUMMARY:

Each year the DOJ provides a formulated amount of funding to local law enforcement through the JAG/BYRNE GRANT PROGRAM. This year grant funding in the amount of \$11,410.00 has been allocated to the City of Marysville. These funds will be used for one additional Taser and accessories, three new radios, and one PBT

RECOMMENDED ACTION: Approval to receive JAG/BYRNE GRANT LOCAL Funds to purchase equipment for the Police Department, in the amount of \$11,410
--



MARYSVILLE POLICE DEPARTMENT

Richard L. Smith, Chief of Police



JAG APPLICATION:

Budget :

A. Personnel	\$0.00
B. Fringe Benefits	\$0.00
C. Equipment	\$11,510 (grant allocation \$11,410)

(1) Tasers	@ 873.85 each	\$ 873.85
(2) Taser Holsters	@ 51.95 each	\$103.90
(2) Taser Magazines	@52.95 each	\$105.90
(3) Radios	@ 3,258.00 each	\$ 9,774.00
(1) PBT (Portable Breath Tester)	@ 555.00 each	\$555.00

Budget Narrative:

The Marysville Police Department will be purchasing one new Taser with extra holsters and magazines, one new portable breath tester, and three new radios to replace failing equipment, taxes, shipping, and associated costs will be paid out of the City of Marysville Police Department General Fund dollars.

3- Portable Radios
127
w/Accessories



Quote Number: QU0000322233
Effective: 29 MAY 2015
Effective To: 28 JUL 2015

Bill-To:

MARYSVILLE POLICE DEPT
1635 GROVE ST
MARYSVILLE, WA 98270
United States

Attention:

Name: pete shove
Phone: 3603638374

Sales Contact:

Name: Tim Thometz
Email: tthometz@daywireless.com
Phone: 425-407-3383

Contract Number: WSCA STANDARD
Freight terms: FOB Destination
Payment terms: Net 30 Due

Item	Quantity	Nomenclature	Description	List price	Your price	Extended Price
1	1	H98UCF9PW6AN	APX6000 700/800 MODEL 2.5 PORTABLE	\$3,877.00	\$2,928.75	\$2,928.75
1a	1	Q241BC	ADD: ANALOG OPERATION	-	-	-
1b	1	H885BK	ENH: 2 YR S/S LITE			
1c	1	QA01648AA	ADD: ADVANCED SYSTEM KEY - HARDWARE KEY			
1d	1	H38BT	ADD: SMARTZONE OPERATION			
2	1	WPLN7080A	CHR IMP SUC EXT US/NA/CA/LA	\$125.00	\$93.75	\$93.75
3	1	PMLN5657B	CARRY ACCESSORY-CASE,APX6000 CC 2.75 SWLBL 2900&2150MAH	\$65.00	\$48.75	\$48.75
4	1	PMLN6129A	SMART 2 WIRE W/TRANS TUBE BLK	\$122.00	\$91.50	\$91.50
5	1	PMNN4403B	BATT STD IP67 LIION2050M 2150T	\$127.00	\$95.25	\$95.25

Total Quote in USD

\$3,258.00

PO Issued to Motorola Solutions Inc. must:

- >Be a valid Purchase Order (PO)/Contract/Notice to Proceed on Company Letterhead. Note: Purchase Requisitions cannot be accepted
- >Have a PO Number/Contract Number & Date
- >Identify "Motorola Solutions Inc." as the Vendor
- >Have Payment Terms or Contract Number
- >Be issued in the Legal Entity's Name
- >Include a Bill-To Address with a Contact Name and Phone Number
- >Include a Ship-To Address with a Contact Name and Phone Number
- >Include an Ultimate Address (only if different than the Ship-To)
- >Be Greater than or Equal to the Value of the Order
- >Be in a Non-Editable Format
- >Identify Tax Exemption Status (where applicable)
- >Include a Signature (as Required)

X 3
= 9,774-

[Sign Up for Email](#) | [Sign In](#) | [Create Account](#)

866.673.7643



0

[Top Phrases](#)

CATEGORIES	BRANDS	PROFESSION	CLOTHING	FOOTWEAR	EQUIPMENT	MEDICAL	CLEARANCE
------------	--------	------------	----------	----------	-----------	---------	-----------

[Equipment](#) > [Personal Equipment](#) > [Forensics | Investigation](#) > [Drug | Alcohol Tests](#) > Intoximeters Alco-Sensor FST



Intoximeters Alco-Sensor FST

Item# LE905 | Mfg# 40-000

[Intoximeters](#)

\$555.00

★ ★ ★ ★ ★ No Reviews | [Be The First to Review](#)

State Versions Also Available!
Call us at 1-800-477-7766 to order.

Select Type... ▾

1 QTY **ADD TO CART** [+ Wishlist](#)



Share this page:

You May Also Like...



TRU SPEC Solid Colors Combat Shirt
\$49.95 to \$58.95

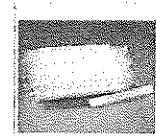

Intoximeters FST Mouthpieces
\$66.99

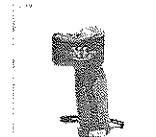

Intoximeters Alco Sensor VXL Breath Tester
\$831.99

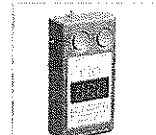

Intoximeters Alco-Sensor III
\$525.00

Product Info	Rating & Reviews
---------------------	------------------

The Intoximeters Alco-Sensor FST (FST) is a pocket-sized, hand-held breath alcohol tester with a symmetric design and rear-facing display, which allows an operator to remain aware of the subject and surroundings. It accurately detects breath alcohol levels from .000 to .400 BrAC and offers both direct and passive sampling. This instrument produces fast, reliable, accurate results in a package that is designed so that the operator has maximum control over the subject during sample collection. The unit is also capable of detecting alcohol in a solution. Rugged enough to survive field use in a policing environment, it is also designed to offer intuitive, simple operating procedures and have sample collection requirements that minimize risk to the operator.

- NHTSA, US DOT approved for evidential or screening use, meets or exceeds the federal model specification for traffic enforcement and Omnibus breath alcohol testing
- Analytical System: Electrochemical (fuel cell) sensor generates an electronic response that is proportional to the Breath Alcohol Concentration
- Measurement Range: 0.000 to 0.440 g/210L
- Accuracy and Precision: Precise evidential-grade results with a consistent output
- Sampling Methods: Designed to collect a direct sample from a subject, a passive sample from a subject, or a headspace sample from an open container
- Symmetrical design allows left or right-handed use
- Allows the operator to control the subject, protect their weapon, easily view both the subject and the instrument display while at the same time preventing the subject's breath from being blown in their direction
- Backlit LCD and illuminated mouthpiece guide for nighttime use
- Fuel cell sensor is specific for alcohol, does not respond to acetone or other substances found in the human breath
- Responds within 5 to 10 seconds on negative or positive samples
- Operates over a wide ambient temperature range: 0° - 50°C (32°F - 122°F)
- CE Mark compliant for EMC compatibility for emissions and immunity
- Simple, one-point calibration
- Capable of automatically or manually collecting direct and passive samples
- Patented mouthpiece design offers a low cost, easy-to-install mouthpiece that directs the breath flow away from the operator
- Powered by two AA batteries for 1000+ tests
- Impact resistant ABS/Polycarbonate blend case
- Last test recall
- High visibility Liquid Crystal Display; back lighting for nighttime viewing
- Includes: carrying case, web-based training, lens protector, rubberized grip, wrist band, 2 passive sample cups (reusable), one sniffer adapter, and 25 mouthpieces
- For replacement mouthpieces, see (LE907)
- 1 year parts and labor warranty
- 4¾"H x 1¾"W x 2¾"D
- 6 oz (with batteries)

Note: The accuracy of any breath alcohol-testing instrument should be checked periodically. This is accomplished by running a standard with a known alcohol concentration through the instrument's sampling system and verifying that the result is within an acceptable tolerance range of the expected value of the standard.

MARYSVILLE POLICE DEPARTMENT

ORDER REQUISITION

REQUESTED BY J. Goldman

DATE June 3, 2015

DEPARTMENT

<input type="checkbox"/>	ADMINISTRATION	<input type="checkbox"/>	INVESTIGATIONS	<input type="checkbox"/>	CUSTODY
<input type="checkbox"/>	OFFICE OPERATIONS	<input type="checkbox"/>	ANIMAL CONTROL	<input type="checkbox"/>	SCHOOL RESOURCE
<input type="checkbox"/>	FIREARMS	<input type="checkbox"/>	PATROL	<input type="checkbox"/>	CRIME PREVENTION

CHECK IF APPLICABLE NEW ITEM REPLACEMENT

VENDOR INFORMATION NAME Pro-Force PHONE _____

ACCOUNT NUMBER _____ CONTACT NAME _____

	ITEM DESCRIPTION (printing: attach samples)	QUANTITY	ORDER #	COST
1.	Blackhawks Holster for X26P	1 (2)		\$51.95
2.	Taser X26P	1		\$873.85
3.	Tactical Performance Power Magazine	1 (2)		\$52.95
4.	Sub-Total		\$1,083.65	\$978.75
5.	Tax (8.9)			\$87.11
6.	Total			\$1,065.86

REASON FOR REQUEST Byrne Grant

SUPERVISOR _____ DATE _____

EQUIPMENT OFFICER _____ DATE _____

LIEUTENANT _____ DATE _____

COMMANDER/ADM _____ DATE _____

BUDGET CODE _____

CHIEF _____ APPROVED DENIED DATE _____

REASON FOR DENIAL _____

ORDER PLACED BY: _____ ADMINISTRATION EQUIPMENT OFFICER OTHER

DATE ORDERED _____ DATE RECEIVED _____

COMMENTS _____

Index #8

CITY OF MARYSVILLE AGENDA BILL

EXECUTIVE SUMMARY FOR ACTION

CITY COUNCIL MEETING DATE: October 12, 2015

AGENDA ITEM: Recreation and Conservation Office ALEA Project Agreement	
PREPARED BY: Jim Ballew	DIRECTOR APPROVAL:
DEPARTMENT: Parks and Recreation	
ATTACHMENTS: RCO/ALEA Project Agreement	
BUDGET CODE:	AMOUNT: \$342,369.00
SUMMARY:	

The City has been awarded an Aquatic Lands Enhancement Account (ALEA) grant in the amount of \$342,369.00 for the Qwuloolt Estuary Trail Project. The grant is a matching grant requiring the city to match the funds at a minimum level of \$342,370.00. The time of performance requires completion of the project by March 31, 2017.

Funding will be utilized to develop a trail system of approximately 1.7 miles on city owned properties adjacent to the Qwuloolt Restoration project. The trail will be paved and include a minimum of two viewpoints overlooking the estuary.

RECOMMENDED ACTION:

Staff recommends the City Council consider authorization of the Mayor to sign the Project Agreement with the RCO for the grant totaling \$342,369.00 through the ALEA program for trail development adjacent to the Qwuloolt restoration project.



Funding Board Project Agreement

Project Sponsor: City of Marysville

Project Number: 14-1492D

Project Title: Qwuloolt Estuary Trail Development

Approval Date: 7/1/2015

A. PARTIES OF THE AGREEMENT

This Project Agreement (Agreement) is entered into between the State of Washington by and through the Recreation and Conservation Funding Board (RCFB or funding board) and the Recreation and Conservation Office, P.O. Box 40917, Olympia, Washington 98504-0917 and City of Marysville (sponsor), 1049 State Ave, Marysville, WA 98270 and shall be binding on the agents and all persons acting by or through the parties.

B. PURPOSE OF AGREEMENT

This Agreement sets out the terms and conditions by which a grant is made from the Aquatic Lands Enhancement Account of the State of Washington. The grant is administered by the Recreation and Conservation Office (RCO) to the sponsor for the project named above per the director's authority granted in RCW 79A.25.020.

C. DESCRIPTION OF PROJECT

The City of Marysville will develop a 1.7 mile trail that will overlook the 340-acre estuary restoration project along the shoreline of Ebey's Slough. The City will pave the trail, build two viewpoints overlooking the restored estuary, and install site furnishings, fencing, and interpretive signs that will highlight the restored estuarine habitats and the efforts of the Tulalip Tribe and partners. The primary recreational opportunity that this project will provide is non-motorized trail use including walking, jogging, and biking.

D. PERIOD OF PERFORMANCE

The period of performance begins on September 15, 2015 (project start date) and ends on March 31, 2017 (project end date). No allowable cost incurred before or after this period is eligible for reimbursement unless specifically provided for by written amendment or addendum to this Agreement or specifically provided for by WAC Titles 286, 420; or RCFB and/or SRFB policies published in RCO manuals as of the effective date of this agreement.

The sponsor must request extensions of the period of performance at least 60 days before the project end date.

The sponsor has obligations beyond this period of performance as described in Section E: On-going Obligations.

E. ON-GOING OBLIGATIONS

For this development and renovation project, the sponsor's on-going obligations shall be in perpetuity and shall survive the completion/termination of this Project Agreement unless otherwise identified in the Agreement or as approved by the funding board. It is the intent of the funding board's conversion policy (see Section 24: Restriction of Conversion) that all lands acquired and/or facilities and areas developed, renovated, or restored with funding assistance remain in the public domain in perpetuity.

F. PROJECT FUNDING

The total grant award provided by the funding board for this project shall not exceed \$342,369.00. The funding board shall not pay any amount beyond that approved for grant funding of the project and within the funding board's percentage as identified below. The sponsor shall be responsible for all total project costs that exceed this amount. The minimum matching share provided by the sponsor shall be as indicated below:

	Percentage	Dollar Amount	Source of Funding
RCFB - Aquatic Lands Enhancement Acct	50.00%	\$342,369.00	State
Project Sponsor	50.00%	\$342,370.00	
Total Project Cost	100.00%	\$684,739.00	

G. FEDERAL FUND INFORMATION

This Agreement is not a federal subaward. This Agreement is funded with a grant from the State of Washington.

H. RIGHTS AND OBLIGATIONS INTERPRETED IN LIGHT OF RELATED DOCUMENTS

All rights and obligations of the parties under this Agreement shall be interpreted in light of the information provided in the sponsor's application and the project summary under which the Agreement has been approved as well as documents produced in the course of administering the Agreement, including the eligible scope activities and milestones report incorporated herein by reference. Provided, to the extent that information contained in such documents is inconsistent with this Agreement, it shall not be used to vary the terms of the Agreement, unless those terms are shown to be subject to an unintended error or omission. This "Agreement" as used here and elsewhere in this document, unless otherwise specifically stated, has the meaning set forth in the definition of the Standard Terms and Conditions.

I. AMENDMENTS MUST BE SIGNED IN WRITING

Except as provided herein, no amendment/deletions of any of the terms or conditions of this Agreement will be effective unless provided in writing and signed by both parties. Except, extensions of the period of performance and minor scope adjustments need only be signed by RCO's director or designee, unless the consent of the sponsor to an extension is required by its auditing policies, regulations, or legal requirements, in which case, no extension shall be effective until so consented.

J. COMPLIANCE WITH APPLICABLE STATUTES, RULES, AND RCFB-SRFB POLICIES

This agreement is governed by, and the sponsor shall comply with, all applicable state and federal laws and regulations, including any applicable RCFB and/or SRFB policies published in RCO manuals as of the effective date of this agreement, all of which are incorporated herein by this reference as if fully set forth.

K. SPECIAL CONDITIONS

None

L. AGREEMENT CONTACTS

The parties will provide all written communications and notices under this Agreement to the mail address or the email address listed below if not both:

Project Contact

Name: Jim Ballew
 Title: Director
 Address: 6915 Armar Rd
 Marysville, WA 98270
 Email: jballew@marysvillewa.gov

RCFB

Recreation and Conservation Office
 Natural Resources Building
 PO Box 40917
 Olympia, Washington 98504-0917

These addresses shall be effective until receipt by one party from the other of a written notice of any change.

M. ENTIRE AGREEMENT

This Agreement, with all amendments and attachments, constitutes the entire Agreement of the parties. No other understandings, oral or otherwise, regarding this Agreement shall exist or bind any of the parties.

N. EFFECTIVE DATE

This Agreement, for project 14-1492D, shall be subject to the written approval of the RCO's authorized representative and shall not be effective and binding until the date signed by both the sponsor and the RCO, whichever is later (Effective Date). Reimbursements for eligible and allowable costs incurred within the period of performance identified in Section D: Period of Performance are allowed only when this Agreement is fully executed and an original is received by RCO.

The sponsor has read, fully understands, and agrees to be bound by all terms and conditions as set forth in this Agreement. The signators listed below represent and warrant their authority to bind the parties to this Agreement.

City of Marysville

By: _____
Name: (printed) _____
Title: _____

Date: _____

State of Washington, Recreation Conservation Office
On behalf of the Recreation and Conservation Funding Board (RCFB or funding board)

By: _____
Kaleen Cottingham
Director
Recreation and Conservation Office

Date: _____

Pre-approved as to form:

By: /s/
Assistant Attorney General

Date: July 20, 2015

Standard Terms and Conditions of the Project Agreement

Table of Contents	Page
SECTION 1. CITATIONS, HEADINGS AND DEFINITIONS.....	6
SECTION 2. PERFORMANCE BY THE SPONSOR.....	7
SECTION 3. ASSIGNMENT.....	7
SECTION 4. RESPONSIBILITY FOR PROJECT.....	7
SECTION 5. INDEMNIFICATION.....	7
SECTION 6. INDEPENDENT CAPACITY OF THE SPONSOR.....	8
SECTION 7. CONFLICT OF INTEREST.....	8
SECTION 8. COMPLIANCE WITH APPLICABLE LAW.....	8
SECTION 9. RECORDS.....	9
SECTION 10. PROJECT FUNDING.....	9
SECTION 11. PROJECT REIMBURSEMENTS.....	10
SECTION 12. ADVANCE PAYMENTS.....	10
SECTION 13. RECOVERY OF PAYMENTS.....	11
SECTION 14. COVENANT AGAINST CONTINGENT FEES.....	11
SECTION 15. INCOME AND USE OF INCOME.....	11
SECTION 16. PROCUREMENT REQUIREMENTS.....	11
SECTION 17. TREATMENT OF EQUIPMENT.....	12
SECTION 18. RIGHT OF INSPECTION.....	12
SECTION 19. STEWARDSHIP AND MONITORING.....	12
SECTION 20. PREFERENCES FOR RESIDENTS.....	12
SECTION 21. ACKNOWLEDGMENT AND SIGNS.....	12
SECTION 22. PROVISIONS APPLYING TO DEVELOPMENT, MAINTENANCE, RENOVATION, AND RESTORATION PROJECTS.....	13
SECTION 23. PROVISIONS APPLYING TO ACQUISITION PROJECTS.....	13
SECTION 24. RESTRICTION ON CONVERSION OF REAL PROPERTY AND/OR FACILITIES TO OTHER USES.....	14
SECTION 25. CONSTRUCTION, OPERATION, USE AND MAINTENANCE OF ASSISTED PROJECTS..	14
SECTION 26. PROVISIONS RELATED TO CORPORATE (INCLUDING NONPROFIT) SPONSORS.....	15

SECTION 27.	PROVISIONS FOR FEDERAL SUBAWARDS ONLY.....	15
SECTION 28.	PROVISIONS FOR FIREARMS AND ARCHERY RANGE RECREATION PROJECTS ONLY.....	17
SECTION 29.	PROVISIONS FOR LAND AND WATER CONSERVATION FUND PROJECTS ONLY.....	17
SECTION 30.	PROVISIONS FOR FARMLAND PRESERVATION ACCOUNT PROJECTS ONLY.....	17
SECTION 31.	PROVISIONS FOR SALMON RECOVERY FUNDING BOARD PROJECTS ONLY.....	17
SECTION 32.	PROVISIONS FOR PUGET SOUND ACQUISITION AND RESTORATION PROJECTS ONLY.....	18
SECTION 33.	PROVISIONS FOR ESTUARY AND SALMON RESTORATION PROGRAM - EPA AND MARINE SHORELINE PROTECTION PROJECTS ONLY.....	20
SECTION 34.	PROVISIONS FOR ESTUARY AND SALMON RESTORATION PROGRAM - EPA PROJECTS ONLY.....	24
SECTION 35.	PROVISIONS FOR MARINE SHORELINE PROTECTION PROGRAM PROJECTS ONLY.....	24
SECTION 36.	ORDER OF PRECEDENCE.....	26
SECTION 37.	AMENDMENTS.....	26
SECTION 38.	LIMITATION OF AUTHORITY.....	26
SECTION 39.	WAIVER OF DEFAULT.....	26
SECTION 40.	APPLICATION REPRESENTATIONS -- MISREPRESENTATIONS OR INACCURACY OR BREACH.....	26
SECTION 41.	SPECIFIC PERFORMANCE.....	27
SECTION 42.	TERMINATION.....	27
SECTION 43.	DISPUTE HEARING.....	27
SECTION 44.	ATTORNEYS' FEES.....	27
SECTION 45.	GOVERNING LAW/VENUE.....	27
SECTION 46.	PROVISIONS APPLICABLE ONLY IF FEDERALLY RECOGNIZED INDIAN TRIBE IS THE SPONSOR.....	28
SECTION 47.	SEVERABILITY.....	28



Standard Terms and Conditions of the Project Agreement

Project Sponsor: City of Marysville

Project Number: 14-1492D

Project Title: Qwuloolt Estuary Trail Development

Approval Date: 7/1/2015

SECTION 1. CITATIONS, HEADINGS AND DEFINITIONS

- A. Any citations referencing specific documents refer to the current version at the date of project Agreement and/or any revisions in the future.
- B. Headings used in this Agreement are for reference purposes only and shall not be considered a substantive part of this Agreement.
- C. Definitions. As used throughout this Agreement, the following terms shall have the meaning set forth below:
- acquisition project** - A project that purchases or receives a donation of fee or less than fee interests in real property. These interests include, but are not limited to, conservation easements, access/trail easements, covenants, water rights, leases, and mineral rights.
- Agreement or Project Agreement** - The document entitled "Project Agreement" accepted by all parties to the present transaction, including without limitation these Standard Terms and Conditions, all attachments, addendums, and amendments, and any intergovernmental agreements or other documents that are incorporated into the Project Agreement subject to any limitations on their effect.
- applicant** - Any party that meets the qualifying standards, including deadlines, for submission of an application soliciting a grant of funds from the funding board.
- application** - The documents and other materials that an applicant submits to the RCO to support the applicant's request for grant funds; this includes materials required for the "Application" in the RCO's automated project information system, and other documents as noted on the application checklist including but not limited to legal opinions, maps, plans, evaluation presentations and scripts.
- C.F.R.** - Code of Federal Regulations
- contractor** - An entity that receives a contract from a sponsor. A contract is a legal instrument by which a non-Federal entity (sponsor) purchases property or services to carry out the project or program under a Federal award. A contractor is not the same as the sponsor or subrecipient. A contract is for the purpose of obtaining goods and services for the non-Federal entity's (sponsor's) own use and creates a procurement relationship with the contractor (2 C.F.R. § 200.23 (2013)).
- development project** - A project that results in the construction of or work resulting in new elements, including but not limited to structures, facilities, and/or materials to enhance outdoor recreation resources.
- director** - The chief executive officer of the Recreation and Conservation Office or that person's designee.
- education project** - A project that provides information, education, and outreach programs for the benefit of outdoor recreationists.
- education and enforcement project** - A project that provides information, education, and outreach programs; encourages responsible recreational behavior, and may provide law enforcement for the benefit of outdoor recreationists.
- equipment** - Tangible personal property (including information technology systems) having a useful life of more than one year and a per-unit acquisition cost which equals or exceeds the lesser of the capitalization level established by the sponsor or \$5,000 (2 C.F.R. § 200.33 (2013)).
- funding board** - The board that authorized the funds in this Agreement, either the Recreation and Conservation Funding Board (RCFB) created under chapter 79A.25.110 RCW, or the Salmon Recovery Funding Board (SRFB) created under chapter 77.85.110 RCW.
- indirect cost** - Costs incurred for a common or joint purpose benefitting more than one cost objective, and not readily assignable to the cost objectives specifically benefitted, without effort disproportionate to the results achieved (2 C.F.R. § 200.56 (2013)).
- landowner agreement** - An agreement that is required between a sponsor and landowner for projects located on land not owned, or otherwise controlled, by the sponsor.
- maintenance project** - A project that maintains existing areas and facilities through repairs and upkeep for the benefit of outdoor recreationists.
- maintenance and operation project** - A project that maintains existing areas and facilities through repairs, upkeep, and routine servicing for the benefit of outdoor recreationists.
- match or matching share** - The portion of the total project cost provided by the sponsor.
- milestone** - An important event with a defined date to track an activity related to implementation of a funded project and monitor significant stages of project accomplishment.
- pass-through entity** - A non-Federal entity that provides a subaward to a subrecipient to carry out part of a Federal program (2 C. F. R. § 200.74 (2013)). If this Agreement is a federal subaward, RCO is the pass-through entity.
- period of performance** - The time during which the sponsor may incur new obligations to carry out the work authorized under this Agreement (2 C.F.R. § 200.77 (2013)).
- planning (RCFB projects only)** - A project that results in one or more of the following: a study, a plan, construction plans and specifications, and permits to increase the availability of outdoor recreational resources.
- planning (SRFB projects only)** - A project that results in a study, assessment, project design, or inventory.
- pre-agreement cost** - A project cost incurred before the period of performance.

project - An undertaking that is, or may be, funded in whole or in part with funds administered by RCO on behalf of the funding board.

project cost - The total allowable costs incurred under this Agreement and all required match share and voluntary committed matching share, including third-party contributions (2 C.F.R. § 200.83 (2013)).

RCO - Recreation and Conservation Office - The state office that provides administrative support to the Recreation and Conservation Funding Board and Salmon Recovery Funding Board. RCO includes the director and staff, created by Chapters 79A.25.110 and 79A.25.150 RCW and charged with administering this Agreement by Chapters 77.85.110 and 79A.25.240 RCW.

reimbursement - RCO's payment of funds from eligible and allowable costs that have already been paid by the sponsor per the terms of the Agreement.

renovation project - A project intended to improve an existing site or structure in order to increase its useful service life beyond original expectations or functions. This does not include maintenance activities to maintain the facility for its originally expected useful service life.

restoration project - A project that brings a site back to its historic function as part of a natural ecosystem or improves the ecological functionality of a site.

RCW - Revised Code of Washington

RTP - Recreational Trails Program - A federal grant program administered by RCO that allows for the development and maintenance of backcountry trails.

secondary sponsor - one of two or more eligible organizations that sponsors a grant-funded project. Of these two sponsors, only one - the primary sponsor - may be the fiscal agent.

sponsor or primary sponsor - The eligible applicant who has been awarded a grant of funds and is bound by this executed Agreement; includes its officers, employees, agents and successors. For projects funded with federal money, the sponsor is a subrecipient, which is a non-Federal entity that receives a subaward from a pass-through entity to carry out part of a Federal program; but does not include an individual that is a beneficiary of such program. A subrecipient may also be a recipient of other Federal awards directly from a Federal awarding agency (2 C.F.R. § 200.93 (2013)).

subaward - An award provided by a pass-through entity to a subrecipient for the subrecipient to carry out part of a Federal award received by the pass-through entity. It does not include payments to a contractor or payments to an individual that is a beneficiary of a Federal program. A subaward may be provided through any form of legal agreement, including an agreement that the pass-through entity considers a contract (2 C.F.R. § 200.92 (2013)). A subaward is for the purpose of carrying out a portion of a Federal award and creates a Federal assistance relationship with the subrecipient (2 C.F.R. § 200.330 (2013)). If this Agreement is a Federal subaward, the subaward amount is the grant program amount in Section F: Project Funding.

subrecipient - Subrecipient means a non-Federal entity that receives a subaward from a pass-through entity to carry out part of a Federal program; but does not include an individual that is a beneficiary of such program. A subrecipient may also be a recipient of other Federal awards directly from a Federal awarding agency (2 C.F.R. § 200.93 (2013)). If this Agreement is a Federal subaward, the sponsor is the subrecipient.

WAC - Washington Administrative Code.

SECTION 2. PERFORMANCE BY THE SPONSOR

The sponsor and secondary sponsor where applicable, shall undertake the project as described in this Agreement, the sponsor's application, and in accordance with the sponsor's proposed goals and objectives described in the application or documents submitted with the application, all as finally approved by the funding board. All submitted documents are incorporated by this reference as if fully set forth herein. Also see Section 36: Order of Precedence.

Timely completion of the project and submission of required documents, including progress and final reports, is important. Failure to meet critical milestones or complete the project, as set out in this Agreement, is a material breach of the Agreement.

SECTION 3. ASSIGNMENT

Neither this Agreement, nor any claim arising under this Agreement, shall be transferred or assigned by the sponsor without prior written consent of the RCO.

SECTION 4. RESPONSIBILITY FOR PROJECT

While the funding board undertakes to assist the sponsor with the project by providing a grant pursuant to this Agreement, the project itself remains the sole responsibility of the sponsor. The funding board undertakes no responsibilities to the sponsor, a secondary sponsor, or to any third party, other than as is expressly set out in this Agreement. The responsibility for the implementation of the project is solely that of the sponsor, as is the responsibility for any claim or suit of any nature by any third party related in any way to the project. When a project is sponsored by more than one entity, any and all sponsors are equally responsible for the project and all post-completion stewardship responsibilities.

SECTION 5. INDEMNIFICATION

The sponsor shall defend, indemnify, and hold the State and its officers and employees harmless from all claims, demands, or suits at law or equity arising in whole or in part from the actual or alleged acts, errors, omissions or negligence of, or the breach of any obligation under this Agreement by, the sponsor or the sponsor's agents, employees, contractors, subcontractors, or vendors, of any tier, or any other persons for whom the sponsor may be legally liable.

Provided that nothing herein shall require a sponsor to defend or indemnify the State against and hold harmless the State from claims, demands or suits based solely upon the negligence of the State, its employees and agents for whom the State is vicariously liable.

Provided further that if the claims or suits are caused by or result from the concurrent negligence of (a) the sponsor or the sponsor's

agents, employees, contractors, subcontractors or vendors, of any tier, or any other persons for whom the Sponsor is legally liable, and (b) the State its employees and agents for whom it is vicariously liable, the indemnity obligation shall be valid and enforceable only to the extent of the sponsor's negligence or the negligence of the sponsor's agents, employees, contractors, subcontractors or vendors, of any tier, or any other persons for whom the sponsor may be legally liable.

This provision shall be included in any Agreement between sponsor and any contractors, subcontractors and vendors, of any tier.

The sponsor shall also defend, indemnify, and hold the State and its officers and employees harmless from all claims, demands, or suits at law or equity arising in whole or in part from the alleged patent or copyright infringement or other allegedly improper appropriation or use of trade secrets, patents, proprietary information, know-how, copyright rights or inventions by the sponsor or the sponsor's agents, employees, contractors, subcontractors or vendors, of any tier, or any other persons for whom the sponsor may be legally liable, in performance of the Work under this Agreement or arising out of any use in connection with the Agreement of methods, processes, designs, information or other items furnished or communicated to State, its agents, officers and employees pursuant to the Agreement; provided that this indemnity shall not apply to any alleged patent or copyright infringement or other allegedly improper appropriation or use of trade secrets, patents, proprietary information, know-how, copyright rights or inventions resulting from State's, its agents', officers' and employees' failure to comply with specific written instructions regarding use provided to State, its agents, officers and employees by the sponsor, its agents, employees, contractors, subcontractors or vendors, of any tier, or any other persons for whom the sponsor may be legally liable.

The sponsor specifically assumes potential liability for actions brought by the sponsor's own employees or its agents against the State and, solely for the purpose of this indemnification and defense, the sponsor specifically waives any immunity under the state industrial insurance law, RCW Title 51.

The RCO is included within the term State, as are all other agencies, departments, boards, or other entities of state government.

SECTION 6. INDEPENDENT CAPACITY OF THE SPONSOR

The sponsor and its employees or agents performing under this Agreement are not officers, employees or agents of the funding board or RCO. The sponsor will not hold itself out as nor claim to be an officer, employee or agent of RCO, a funding board or of the state of Washington, nor will the sponsor make any claim of right, privilege or benefit which would accrue to an employee under Chapters 41.06 or 28B RCW.

The sponsor is responsible for withholding and/or paying employment taxes, insurance, or deductions of any kind required by federal, state, and/or local laws.

SECTION 7. CONFLICT OF INTEREST

Notwithstanding any determination by the Executive Ethics Board or other tribunal, RCO may, in its sole discretion, by written notice to the sponsor terminate this Agreement if it is found after due notice and examination by RCO that there is a violation of the Ethics in Public Service Act, RCW 42.52; or any similar statute involving the sponsor in the procurement of, or performance under, this Agreement.

In the event this Agreement is terminated as provided herein, RCO shall be entitled to pursue the same remedies against the sponsor as it could pursue in the event of a breach of the Agreement by the sponsor. The rights and remedies of RCO provided for in this clause shall not be exclusive and are in addition to any other rights and remedies provided by law or this Agreement.

SECTION 8. COMPLIANCE WITH APPLICABLE LAW

The sponsor will implement the Agreement in accordance with applicable federal, state, and local laws, regulations and RCO and funding board policies regardless of whether the sponsor is a public or non-public organization.

The sponsor shall comply with, and RCO is not responsible for determining compliance with, any and all applicable federal, state, and local laws, regulations, and/or policies, including, but not limited to: State Environmental Policy Act; Industrial Insurance Coverage; Architectural Barriers Act; permits (shoreline, Hydraulics Project Approval, demolition); land use regulations (critical areas ordinances, Growth Management Act); federal and state safety and health regulations (Occupational Safety and Health Administration/Washington Industrial Safety and Health Act); and Buy American Act.

- A. **Nondiscrimination Laws.** The sponsor shall comply with all applicable federal, state, and local nondiscrimination laws and/or policies, including but not limited to: the Americans with Disabilities Act; Civil Rights Act; and the Age Discrimination Act. In the event of the sponsor's noncompliance or refusal to comply with any nondiscrimination law or policy, the Agreement may be rescinded, cancelled, or terminated in whole or in part, and the sponsor may be declared ineligible for further grant awards from the funding board. The sponsor is responsible for any and all costs or liability arising from the sponsor's failure to so comply with applicable law.
- B. **Wages and Job Safety.** The sponsor agrees to comply with all applicable laws, regulations, and policies of the United States and the State of Washington which affect wages and job safety. The sponsor agrees when state prevailing wage laws (RCW 39.12) are applicable, to comply with such laws, to pay the prevailing rate of wage to all workers, laborers, or mechanics employed in the performance of any part of this contract, and to file a statement of intent to pay prevailing wage with the Washington State Department of Labor and Industries as required by RCW 39.12.040. The sponsor also agrees to comply with the provisions of the rules and regulations of the Washington State Department of Labor and Industries.

- C. **Archaeological and Cultural Resources.** The RCO facilitates the review of applicable projects for potential impacts to archaeological sites and state cultural resources. The sponsor must assist RCO in compliance with Executive Order 05-05 or the National Historic Preservation Act before initiating ground-disturbing activity. The funding board requires documented compliance with Executive Order 05-05 or Section 106 of the National Historic Preservation Act, whichever is applicable to the project. If a federal agency declines to consult, the sponsor shall comply with the requirements of Executive Order 05-05. In the event that archaeological or historic materials are discovered during project activities, work in the location of discovery and immediate vicinity must stop instantly, the area must be secured, and notification must be provided to the following: concerned Tribes' cultural staff and cultural committees, RCO, and the State Department of Archaeology and Historic Preservation. If human remains are discovered during project activity, work in the location of discovery and immediate vicinity must stop instantly, the area must be secured, and notification provided to the concerned Tribe's cultural staff and cultural committee, RCO, State Department of Archaeology, the coroner and local law enforcement in the most expeditious manner possible according to RCW 68.50.
- D. **Restrictions on Grant Use.** No part of any funds provided under this grant shall be used, other than for normal and recognized executive-legislative relationships, for publicity or propaganda purposes, or for the preparation, distribution, or use of any kit, pamphlet, booklet, publication, radio, television, or video presentation designed to support or defeat legislation pending before the U.S. Congress or any state legislature.

No part of any funds provided under this grant shall be used to pay the salary or expenses of any sponsor, or agent acting for such sponsor, related to any activity designed to influence legislation or appropriations pending before the U.S. Congress or any state legislature.

- E. **Debarment and Certification.** By signing the Agreement with RCO, the sponsor certifies that neither it nor its principals nor any other lower tier participant are presently debarred, suspended, proposed for debarment, declared ineligible or voluntarily excluded from participation in this transaction by Washington State Labor and Industries. Further, the sponsor agrees not to enter into any arrangements or contracts related to this Agreement with any party that is on the "Contractors not Allowed to Bid on Public Works Projects" list.

SECTION 9. RECORDS

- A. **Maintenance.** The sponsor shall maintain books, records, documents, data and other evidence relating to this Agreement and performance of the services described herein, including but not limited to accounting procedures and practices which sufficiently and properly reflect all direct and indirect costs of any nature expended in the performance of this Agreement. Sponsor shall retain such records for a period of six years from the date RCO deems the project complete, as defined in Section 11: Project Reimbursements. If any litigation, claim or audit is started before the expiration of the six (6) year period, the records shall be retained until all litigation, claims, or audit findings involving the records have been resolved.
- B. **Access to Records and Data.** At no additional cost, the records relating to the Agreement, including materials generated under the Agreement, shall be subject at all reasonable times to inspection, review or audit by RCO, personnel duly authorized by RCO, the Office of the State Auditor, and federal and state officials so authorized by law, regulation or Agreement. This includes access to all information that supports the costs submitted for payment under the grant and all findings, conclusions, and recommendations of the sponsor's reports, including computer models and methodology for those models.
- C. **Public Records.** Sponsor acknowledges that the funding board is subject to RCW 42.56 and that this Agreement and any records sponsor submits or has submitted to the State shall be a public record as defined in RCW 42.56. RCO administers public records requests per WAC 286-06 and 420-04. Additionally, in compliance with RCW 77.85.130(8), sponsor agrees to disclose any information in regards to expenditure of any funding received from the SRFB. By submitting any record to the state sponsor understands that the State may be requested to disclose or copy that record under the state public records law, currently codified at RCW 42.56. The sponsor warrants that it possesses such legal rights as are necessary to permit the State to disclose and copy such document to respond to a request under state public records laws. The sponsor hereby agrees to release the State from any claims arising out of allowing such review or copying pursuant to a public records act request, and to indemnify against any claims arising from allowing such review or copying and pay the reasonable cost of state's defense of such claims.

SECTION 10. PROJECT FUNDING

- A. **Authority.** This agreement is funded through a grant award from the recreation and conservation funding board per WAC 286-13-050 and/or the salmon recovery funding board per WAC 420-04-050. The director of RCO enters into this agreement per delegated authority in RCW 79A.25.020 and 77.85.120.
- B. **Additional Amounts.** The funding board shall not be obligated to pay any amount beyond the dollar amount as identified in this Agreement, unless an additional amount has been approved in advance by the funding board or director and incorporated by written amendment into this Agreement.
- C. **Before the Agreement.** No expenditure made, or obligation incurred, by the sponsor before the project start date shall be eligible for grant funds, in whole or in part, unless specifically provided for by funding board policy, such as a waiver of retroactivity or program specific eligible pre-Agreement costs. For reimbursements of such costs, this Agreement must be fully executed and an original received by RCO. The dollar amounts identified in this Agreement may be reduced as necessary to exclude any such expenditure from reimbursement.
- D. **Requirements for Federal Subawards.** Pre-agreements costs before the federal award date in Section F: Project Funding are ineligible unless approved by the federal award agency (2 C.F.R. § 200.458 (2013)).

- E. After the Period of Performance. No expenditure made, or obligation incurred, following the period of performance shall be eligible, in whole or in part, for grant funds hereunder. In addition to any remedy the funding board may have under this Agreement, the grant amounts identified in this Agreement shall be reduced to exclude any such expenditure from participation.

SECTION 11. PROJECT REIMBURSEMENTS

- A. Reimbursement Basis. This Agreement is administered on a reimbursement basis per WAC 286-13 and/or 420-12. The sponsors may only request reimbursement for eligible and allowable costs incurred during the period of performance. The sponsor may only request reimbursement after (1) this Agreement has been fully executed and (2) the sponsor has remitted payment to its vendors. RCO will authorize disbursement of project funds only on a reimbursable basis at the percentage as defined in Section F: Project Funding. Reimbursement shall not be approved for any expenditure not incurred by the sponsor or for a donation used as part of its matching share. RCO does not reimburse for donations, which the sponsor may use as part of its percentage. All reimbursement requests must include proper documentation of expenditures as required by RCO.
- B. Reimbursement Request Frequency. Sponsors are encouraged to send RCO a reimbursement request at least quarterly. Sponsors are required to submit a reimbursement request to RCO, at a minimum for each project at least once a year for reimbursable activities occurring between July 1 and June 30 or as identified in the milestones. Sponsors must refer to the most recently published/adopted RCO policies and procedures regarding reimbursement requirements.
- C. Compliance and Payment. The obligation of RCO to pay any amount(s) under this Agreement is expressly conditioned on strict compliance with the terms of this Agreement by the sponsor.
- D. Retainage Held Until Project Complete. RCO reserves the right to withhold disbursement of up to the final ten percent (10%) of the total amount of the grant to the sponsor until the project has been completed. A project is considered "complete" when:
1. All approved or required activities outlined in the Agreement are done;
 2. On-site signs are in place (if applicable);
 3. A final project report is submitted to and accepted by RCO;
 4. Any other required documents are complete and submitted to RCO;
 5. A final reimbursement request is submitted to RCO;
 6. The completed project has been accepted by RCO;
 7. Final amendments have been processed; and
 8. Fiscal transactions are complete.
9. RCO has accepted a final boundary map, if required for the project, for which the Agreement terms will apply in the future.
- E. Requirements for Federal Subawards: Match. The sponsor's matching share must comply with 2 C.F.R. § 200.306 (2013). Any shared costs or matching funds and all contributions, including cash and third party in-kind contributions, must be accepted as part of the sponsor's matching share when such contributions meet all of the following criteria:
1. Are verifiable from the non-Federal entity's (sponsor's) records;
 2. Are not included as contributions for any other Federal award;
 3. Are necessary and reasonable for accomplishment of project or program objectives;
 4. Are allowable under 2 C.F.R. Part 200, Subpart E-Cost Principles (2013);
 5. Are not paid by the Federal Government under another Federal award, except where the Federal statute authorizing a program specifically provides that Federal funds made available for such program can be applied to matching or cost sharing requirements of other Federal programs;
 6. Are provided for in the approved budget when required by the Federal awarding agency identified in Section G: Federal Fund Information of this Agreement; and
 7. Conform to other provisions of 2 C.F.R. Part 200, Subpart D-Post Federal Award Requirements (2013), as applicable.
- F. Requirements for Federal Subawards: Close out. Per 2 C.F.R § 200.343 (2013), the non-Federal entity (sponsor) must:
1. Submit, no later than 90 calendar days after the end date of the period of performance, all financial, performance, and other reports as required by the terms and conditions of the Federal award. The Federal awarding agency or pass-through entity (RCO) may approve extensions when requested by the sponsor.
 2. Liquidate all obligations incurred under the Federal award not later than 90 calendar days after the end date of the period of performance as specified in the terms and conditions of the Federal award.
 3. Refund any balances of unobligated cash that the Federal awarding agency or pass-through entity (RCO) paid in advance or paid and that are not authorized to be retained by the non-Federal entity (sponsor) for use in other projects. See OMB Circular A-129 and see 2 C.F.R § 200.345 Collection of amounts due (2013), for requirements regarding unreturned amounts that become delinquent debts.
 4. Account for any real and personal property acquired with Federal funds or received from the Federal Government in accordance with 2 C.F.R §§ 200.310 Insurance coverage through 200.316 Property trust relationship and 200.329 Reporting on real property (2013).

SECTION 12. ADVANCE PAYMENTS

Advance payments of or in anticipation of goods or services are not allowed unless approved by the RCO director and are consistent with legal requirements and Manual 8: Reimbursements. See WAC 420-12.

SECTION 13. RECOVERY OF PAYMENTS

- A. Recovery for Noncompliance. In the event that the sponsor fails to expend funds under this Agreement in accordance with state and federal laws, and/or the provisions of the Agreement, or meet its percentage of the project total, RCO reserves the right to recover grant award funds in the amount equivalent to the extent of noncompliance in addition to any other remedies available at law or in equity.
- B. Overpayment Payments. The sponsor shall reimburse RCO for any overpayment or erroneous payments made under the Agreement. Repayment by the sponsor of such funds under this recovery provision shall occur within 30 days of demand by RCO. Interest shall accrue at the rate of twelve percent (12%) per annum from the time that payment becomes due and owing.
- C. Requirements for Federal Subawards. The pass-through entity (RCO) may impose any of the remedies as authorized in 2 C.F.R. §§ 200.207 Specific conditions and/or 200.338 Remedies for noncompliance (2013).

SECTION 14. COVENANT AGAINST CONTINGENT FEES

The sponsor warrants that no person or selling agent has been employed or retained to solicit or secure this Agreement on an Agreement or understanding for a commission, percentage, brokerage or contingent fee, excepting bona fide employees or bona fide established agents maintained by the sponsor for the purpose of securing business. RCO shall have the right, in the event of breach of this clause by the sponsor, to terminate this Agreement without liability or, in its discretion, to deduct from the Agreement grant amount or consideration or recover by other means the full amount of such commission, percentage, brokerage or contingent fee.

SECTION 15. INCOME AND USE OF INCOME

- A. RCFB Projects. See WAC 286-13-110 for additional requirements for projects funded from the RCFB.
- B. Income.
 - 1. Compatible source. The source of any income generated in a funded project or project area must be compatible with the funding source and the Agreement.
 - 2. Fees. User and/or other fees may be charged in connection with land acquired or facilities developed, maintained, renovated, or restored with funding board grants if the fees are consistent with the:
 - (a) Value of any service(s) furnished;
 - (b) Value of any opportunities furnished; and
 - (c) Prevailing range of public fees in the state for the activity involved.
 - (d) Excepted are Firearms and Archery Range Recreation Program safety classes (firearm and/or hunter) for which a facility/range fee must not be charged (RCW 79A.25.210).
- C. Use of income. Regardless of whether income or fees in a project work site (including entrance, utility corridor permit, cattle grazing, timber harvesting, farming, etc.) are gained during or after the reimbursement period cited in the Agreement, unless precluded by state or federal law, the revenue may only be used to offset:
 - 1. The sponsor's matching resources;
 - 2. The project's total cost;
 - 3. The expense of operation, maintenance, stewardship, monitoring, and/or repair of the facility or program assisted by the funding board grant;
 - 4. The expense of operation, maintenance, stewardship, monitoring, and/or repair of other similar units in the sponsor's system; and/or
 - 5. Capital expenses for similar acquisition and/or development and renovation.
- D. Requirements for Federal Subawards. Sponsors must also comply with 2 C.F.R. § 200.307 Program income (2013).

SECTION 16. PROCUREMENT REQUIREMENTS

- A. Procurement Requirements. If Sponsors have a procurement process that follows applicable state and/or required federal procurement principles, it must be followed. If no such process exists the sponsor must follow these minimum procedures:
 - 1. Publish a notice to the public requesting bids/proposals for the project;
 - 2. Specify in the notice the date for submittal of bids/proposals;
 - 3. Specify in the notice the general procedure and criteria for selection; and
 - 4. Comply with the same legal standards regarding unlawful discrimination based upon race, ethnicity, sex, or sex-orientation that are applicable to state agencies in selecting a bidder or proposer.

This procedure creates no rights for the benefit of third parties, including any proposers, and may not be enforced or subject to review of any kind or manner by any other entity other than the RCO. Sponsors may be required to certify to the RCO that they have followed any applicable state and/or federal procedures or the above minimum procedure where state or federal procedures do not apply.

- B. Requirements for Federal Subawards.
1. For all Federal subawards except RTP projects, non-Federal entities (sponsors) must follow 2 C.F.R §§ 200.318 General procurement standards through 200.326 Contract Provisions (2013).
 2. For RTP subawards, sponsors follow such policies and procedures allowed by the State when procuring property and services under a Federal award (2 C.F.R § 1201.317 (2013)). State procurement policies are in subsection A of this section.

SECTION 17. TREATMENT OF EQUIPMENT

- A. Discontinued Use. Equipment shall remain in the possession of the sponsor for the duration of the project or applicable grant program. When the sponsor discontinues use of the equipment for the purpose for which it was funded, RCO will require the sponsor to deliver the equipment to RCO, dispose of the equipment according to RCO policies, or return the fair market value of the equipment to RCO. Equipment shall be used only for the purpose of this Agreement, unless otherwise provided herein or approved by RCO in writing.
- B. Loss or Damage. The sponsor shall be responsible for any loss or damage to equipment which results from the negligence of the sponsor or which results from the failure on the part of the sponsor to maintain and administer that equipment in accordance with sound management practices.
- C. Requirements for Federal Subawards. Except RTP, procedures for managing equipment (including replacement equipment), whether acquired in whole or in part under a Federal award, until disposition takes place will, as a minimum, meet the following requirements (2 C.F.R § 200.313 (2013)):
1. Property records must be maintained that include a description of the property, a serial number or other identification number, the source of funding for the property (including the FAIN), who holds title, the acquisition date, and cost of the property, percentage of Federal participation in the project costs for the Federal award under which the property was acquired, the location, use and condition of the property, and any ultimate disposition data including the date of disposal and sale price of the property.
 2. A physical inventory of the property must be taken and the results reconciled with the property records at least once every two years.
 3. A control system must be developed to ensure adequate safeguards to prevent loss, damage, or theft of the property. Any loss, damage, or theft must be investigated.
 4. Adequate maintenance procedures must be developed to keep the property in good condition.
 5. If the non-Federal entity is authorized or required to sell the property, proper sales procedures must be established to ensure the highest possible return.
- D. Requirements for RTP Subawards. The subrecipient (sponsor) shall follow such policies and procedures allowed by the State with respect to the use, management and disposal of equipment acquired under a Federal award (2 C.F.R § 1201.313 (2013)).

SECTION 18. RIGHT OF INSPECTION

The sponsor shall provide right of access to the project to RCO, or any of its officers, or to any other authorized agent or official of the state of Washington or the federal government, at all reasonable times, in order to monitor and evaluate performance, compliance, and/or quality assurance under this Agreement.

If a landowner agreement or other form of control and tenure as described in Section 22.B: Control and Tenure has been executed, it will further stipulate and define the funding board and RCO's right to inspect and access lands acquired or developed with funding board assistance.

SECTION 19. STEWARDSHIP AND MONITORING

Sponsor agrees to perform monitoring and stewardship functions as stated in policy documents approved by the funding boards or RCO. Sponsor further agrees to utilize, where applicable and financially feasible, any monitoring protocols recommended by the funding board.

SECTION 20. PREFERENCES FOR RESIDENTS

Sponsors shall not express a preference for users of grant assisted projects on the basis of residence (including preferential reservation, membership, and/or permit systems) except that reasonable differences in admission and other fees may be maintained on the basis of residence. Even so, the funding board discourages the imposition of differential fees. Fees for nonresidents must not exceed twice the fee imposed on residents. Where there is no fee for residents but a fee is charged to nonresidents, the nonresident fee shall not exceed the amount that would be imposed on residents at comparable state or local public facilities.

SECTION 21. ACKNOWLEDGMENT AND SIGNS

- A. Publications. The sponsor shall include language which acknowledges the funding contribution of the applicable grant program to this project in any release or other publication developed or modified for, or referring to, the project during the project period and in the future.
- B. Signs. The sponsor also shall post signs or other appropriate media during the project period of performance and in the future at project entrances and other locations on the project which acknowledge the applicable grant program's funding contribution, unless exempted in funding board policy or waived by the director.

- C. Ceremonies. The sponsor shall notify RCO no later than two weeks before a dedication ceremony for this project. The sponsor shall verbally acknowledge the applicable grant program's funding contribution at all dedication ceremonies.
- D. Federally Funded Projects. When issuing statements, press releases, requests for proposals, bid solicitations, and other documents describing a project funded in whole or in part with federal money provided for in this grant, sponsors shall clearly state:
 1. The fund source;
 2. The percentage of the total costs of the project that is financed with federal money;
 3. The dollar amount of federal funds for the project; and
 4. The percentage and dollar amount of the total costs of the project that is financed by nongovernmental sources.

SECTION 22. PROVISIONS APPLYING TO DEVELOPMENT, MAINTENANCE, RENOVATION AND RESTORATION PROJECTS

The following provisions shall be in force only if the project described in this Agreement is for construction of land or facilities in a development, maintenance, renovation or restoration project:

- A. Document Review and Approval. The sponsor agrees to submit one copy of all construction plans and specifications to RCO for review prior to implementation or as otherwise identified in the milestones. Review and approval by RCO will be for compliance with the terms of this Agreement. Only change orders that impact the amount of funding or changes to the scope of the project as described to and approved by the funding board or RCO must receive prior written approval.
- B. Control and Tenure. The sponsor must provide documentation that shows appropriate tenure (landowner agreement, long-term lease, easement, or fee simple ownership) for the land proposed for construction. The documentation must meet current RCO requirements identified in the appropriate grant program policy manual as of the effective date of this Agreement.
- C. Nondiscrimination. Except where a nondiscrimination clause required by a federal funding agency is used, the sponsor shall insert the following nondiscrimination clause in each contract for construction of this project:

"During the performance of this contract, the contractor agrees to comply with all federal and state nondiscrimination laws, regulations and policies."

- D. Use of Best Management Practices. Sponsors are encouraged to use best management practices developed as part of the Washington State Aquatic Habitat Guidelines (AHG) Program. AHG documents include "Integrated Streambank Protection Guidelines", 2002; "Protecting Nearshore Habitat and Functions in Puget Sound", 2010; "Stream Habitat Restoration Guidelines", 2012; "Water Crossing Design Guidelines", 2013; and "Marine Shoreline Design Guidelines", 2014. These documents, along with new and updated guidance documents, and other information are available on the AHG Web site. Sponsors are also encouraged to use best management practices developed by the Washington Invasive Species Council (WISC) described in "Reducing Accidental Introductions of Invasive Species" which is available on the WISC Web site.

SECTION 23. PROVISIONS APPLYING TO ACQUISITION PROJECTS

The following provisions shall be in force only if the project described in this Agreement is an acquisition project:

- A. Evidence of Land Value. Before disbursement of funds by RCO as provided under this Agreement, the sponsor agrees to supply documentation acceptable to RCO that the cost of the property rights acquired has been established according to funding board policy.
- B. Evidence of Title. The sponsor agrees to provide documentation that shows the type of ownership interest for the property that has been acquired. This shall be done before any payment of financial assistance.
- C. Legal Description of Real Property Rights Acquired. The legal description of the real property rights purchased with funding assistance provided through this project Agreement (and protected by a recorded conveyance of rights to the State of Washington) shall be incorporated into the Agreement before final payment.
- D. Conveyance of Rights to the State of Washington. When real property rights (both fee simple and lesser interests) are acquired, the sponsor agrees to execute an appropriate document conveying certain rights and responsibilities to RCO, on behalf of the State of Washington. These documents include a Deed of Right, Assignment of Rights, Easements and/or Leases as described below. The sponsor agrees to use document language provided by RCO, to record the executed document in the County where the real property lies, and to provide a copy of the recorded document to RCO. The document required will vary depending on the project type, the real property rights being acquired and whether or not those rights are being acquired in perpetuity.
 1. Deed of Right. The Deed of Right conveys to the people of the state of Washington the right to preserve, protect, and/or use the property for public purposes consistent with the fund source. See WAC 420-12 or 286-13. Sponsors shall use this document when acquiring real property rights that include the underlying land. This document may also be applicable for those easements where the sponsor has acquired a perpetual easement for public purposes.
 2. Assignment of Rights. The Assignment of Rights document transfers certain rights such as access and enforcement to RCO. Sponsors shall use this document when an easement or lease is being acquired for habitat conservation or salmon recovery purposes. The Assignment of Rights requires the signature of the underlying landowner and must be incorporated by reference in the easement document.
 3. Easements and Leases. The sponsor may incorporate required language from the Deed of Right or Assignment of Rights directly into the easement or lease document, thereby eliminating the requirement for a separate document. Language will depend on the situation; sponsor must obtain RCO approval on the draft language prior to executing the easement or lease.

E. Real Property Acquisition and Relocation Assistance

1. Federal Acquisition Policies. When federal funds are part of this Agreement, the Sponsor agrees to comply with the terms and conditions of the Uniform Relocation Assistance and Real Property Acquisition Policies Act of 1970, 84 Stat. 1894 (1970)--Public Law 91-646, as amended by the Surface Transportation and Uniform Relocation Assistance Act, PL 100-17-1987, and applicable regulations and procedures of the federal agency implementing that Act.
2. State Acquisition Policies. When state funds are part of this Agreement, the sponsor agrees to comply with the terms and conditions of the Uniform Relocation Assistance and Real Property Acquisition Policy of the State of Washington, Chapter 8.26 RCW, and Chapter 468-100 WAC.
3. Housing and Relocation. In the event that housing and relocation costs, as required by federal law set out in subsection (1) above and/or state law set out in subsection (2) above, are involved in the execution of this project, the sponsor agrees to provide any housing and relocation assistance required.

F. Buildings and Structures. In general, grant funds are to be used for outdoor recreation, habitat conservation, or salmon recovery. Sponsors agree to remove or demolish ineligible structures. Sponsors must consult RCO regarding compliance with Section 8.C.: Archaeological and Cultural Resources before structures are removed or demolished.

G. Hazardous Substances.

1. Certification. The sponsor shall inspect, investigate, and conduct an environmental audit of the proposed acquisition site for the presence of hazardous substances, as defined in RCW 70.105D.020(10), and certify:
 - a. No hazardous substances were found on the site, or
 - b. Any hazardous substances found have been treated and/or disposed of in compliance with applicable state and federal laws, and the site deemed "clean."
2. Responsibility. Nothing in this provision alters the sponsor's duties and liabilities regarding hazardous substances as set forth in RCW 70.105D.
3. Hold Harmless. The sponsor will defend, protect and hold harmless RCO and any and all of its employees and/or agents, from and against any and all liability, cost (including but not limited to all costs of defense and attorneys' fees) and any and all loss of any nature from any and all claims or suits resulting from the presence of, or the release or threatened release of, hazardous substances on the property the sponsor is acquiring.

H. Requirements for Federal Subawards. The non-Federal entity (sponsor) must submit reports at least annually on the status of real property in which the Federal Government retains an interest, unless the Federal interest in the real property extends 15 years or longer. In those instances where the Federal interest attached is for a period of 15 years or more, the Federal awarding agency or the pass-through entity (RCO), at its option, may require the sponsor to report at various multi-year frequencies (e.g., every two years or every three years, not to exceed a five-year reporting period; or a Federal awarding agency or RCO may require annual reporting for the first three years of a Federal award and thereafter require reporting every five years) (2 C.F.R § 200.329 (2013)).

SECTION 24. RESTRICTION ON CONVERSION OF REAL PROPERTY AND/OR FACILITIES TO OTHER USES

The sponsor shall not at any time convert any real property (including any interest therein) or facility acquired, developed, maintained, renovated, and/or restored pursuant to this Agreement to uses other than those purposes for which funds were approved without prior approval of the funding board in compliance with applicable statutes, rules, and funding board policies. Also see WAC Title 286 or 420. It is the intent of the funding board's conversion policy, current or as amended in the future, that all real property or facilities acquired, developed, renovated, and/or restored with funding assistance remain in the public domain in perpetuity unless otherwise identified in the Agreement or as approved by the funding board. Determination of whether a conversion has occurred shall be based upon applicable law and RCFB/SRFB policies.

For acquisition projects that are term limited, such as one involving a lease or a term-limited restoration, renovation or development project or easement, this restriction on conversion shall apply only for the length of the term, unless otherwise provided in written documents or required by applicable state or federal law. In such case, the restriction applies to such projects for the length of the term specified by the lease, easement, deed, or landowner agreement.

When a conversion has been determined to have occurred, the sponsor is required to remedy the conversion per established funding board policies.

SECTION 25. CONSTRUCTION, OPERATION, USE AND MAINTENANCE OF ASSISTED PROJECTS

The following provisions shall be in force only if the project described in this Agreement is an acquisition, development, maintenance, renovation or restoration project:

- A. Property and facility operation and maintenance. Sponsor must ensure that properties or facilities assisted with funding board funds, including undeveloped sites, are built, operated, used, and maintained:
 1. According to applicable federal, state, and local laws and regulations, including public health standards and building codes.
 2. In a reasonably safe condition for the project's intended use.
 3. Throughout its estimated useful service life so as to prevent undue deterioration.
 4. In compliance with all federal and state nondiscrimination laws, regulations and policies.

- B. Open to the public. Facilities open and accessible to the general public must:
1. Be constructed and maintained to meet or exceed the minimum requirements of the most current local or state codes, Uniform Federal Accessibility Standards, guidelines, or rules, including but not limited to: the International Building Code, the Americans with Disabilities Act, and the Architectural Barriers Act, as updated.
 2. Appear attractive and inviting to the public except for brief installation, construction, or maintenance periods.
 3. Be available for use by the general public without reservation at reasonable hours and times of the year, according to the type of area or facility.

SECTION 26. PROVISIONS RELATED TO CORPORATE (INCLUDING NONPROFIT) SPONSORS

A corporate sponsor, including any nonprofit sponsor, shall:

- A. Maintain corporate status with the state, including registering with the Washington Secretary of State's office, throughout the sponsor's obligation to the project as identified in the Agreement.
- B. Notify RCO prior to corporate dissolution at any time during the period of performance or long-term obligations. Within 30 days of dissolution the sponsor shall name a qualified successor that will agree in writing to assume any on-going project responsibilities. A qualified successor is any party eligible to apply for funds in the subject grant program and capable of complying with the terms and conditions of this Agreement. RCO will process an amendment transferring the sponsor's obligation to the qualified successor if requirements are met.
- C. Sites or facilities open to the public may not require exclusive use, (e.g., members only).

SECTION 27. PROVISIONS FOR FEDERAL SUBAWARDS ONLY

The following provisions shall be in force only if the project described in this Agreement is funded with a federal subaward as identified in Section G: Federal Fund Information.

- A. Equal Employment Opportunity. Except as otherwise provided under 41 C.F.R. 60, all contracts that meet the definition of "federally assisted construction contract" in 41 C.F.R. § 60-1.3 must include the equal opportunity clause provided under 41 C.F.R. § 60-1.4(b), in accordance with Executive Order 11246, "Equal Employment Opportunity" (30 Fed. Reg. 12319, 12935, 3 C.F.R. 1964, 1965 Comp., p. 339), as amended by Executive Order 11375, "Amending Executive Order 11246 Relating to Equal Employment Opportunity," and implementing regulations at 41 C.F.R. § 60, "Office of Federal Contract Compliance Programs, Equal Employment Opportunity, Department of Labor."

Federally assisted construction contract means any agreement or modification thereof between any applicant and a person for construction work which is paid for in whole or in part with funds obtained from the Government or borrowed on the credit of the Government pursuant to any Federal program involving a grant, contract, loan, insurance, or guarantee, or undertaken pursuant to any Federal program involving such grant, contract, loan, insurance, or guarantee, or any application or modification thereof approved by the Government for a grant, contract, loan, insurance, or guarantee under which the applicant itself participates in the construction work. (41 C.F.R. § 60-1.3)

Construction work means the construction, rehabilitation, alteration, conversion, extension, demolition or repair of buildings, highways, or other changes or improvements to real property, including facilities providing utility services. The term also includes the supervision, inspection, and other onsite functions incidental to the actual construction. (41 C.F.R. § 60-1.3)

- B. Davis-Bacon Act, as amended (40 U.S.C. 3141-3148). When required by Federal program legislation, all prime construction contracts in excess of \$2,000 awarded by non-Federal entities (sponsors) must include a provision for compliance with the Davis-Bacon Act (40 U.S.C. 3141-3144, and 3146-3148) as supplemented by Department of Labor regulations (29 C.F.R. § 5, "Labor Standards Provisions Applicable to Contracts Covering Federally Financed and Assisted Construction").

In accordance with the statute, contractors must be required to pay wages to laborers and mechanics at a rate not less than the prevailing wages specified in a wage determination made by the Secretary of Labor. In addition, contractors must be required to pay wages not less than once a week. The non-Federal entity (sponsor) must place a copy of the current prevailing wage determination issued by the Department of Labor in each solicitation. The decision to award a contract or subcontract must be conditioned upon the acceptance of the wage determination. The non-Federal entity (sponsor) must report all suspected or reported violations to the Federal awarding agency identified in Section G: Federal Fund Information.

The contracts must also include a provision for compliance with the Copeland "Anti-Kickback" Act (40 U. S. C. 3145), as supplemented by Department of Labor regulations (29 C.F.R Part 3, "Contractors and Subcontractors on Public Building or Public Work Financed in Whole or in Part by Loans or Grants from the United States"). The Act provides that each contractor or subrecipient (sponsor) must be prohibited from inducing, by any means, any person employed in the construction, completion, or repair of public work, to give up any part of the compensation to which he or she is otherwise entitled. The non-Federal entity (sponsor) must report all suspected or reported violations to the Federal awarding agency identified in Section G: Federal Fund Information.

- C. Contract Work Hours and Safety Standards Act (40 U.S.C. 3701-3708). Where applicable, all contracts awarded by the non-Federal entity (sponsor) in excess of \$100,000 that involve the employment of mechanics or laborers must include a provision for compliance with 40 U.S.C. 3702 and 3704, as supplemented by Department of Labor regulations (29 C.F.R. Part 5). Under 40 U.S.C. 3702 of the Act, each contractor must be required to compute the wages of every mechanic and laborer on the basis of a standard work week of 40 hours. Work in excess of the standard work week is permissible provided that the worker is compensated at a rate of not less than one and a half times the basic rate of pay for all hours worked in excess of 40 hours in the work week.

The requirements of 40 U.S.C. 3704 are applicable to construction work and provide that no laborer or mechanic must be required to work in surroundings or under working conditions which are unsanitary, hazardous or dangerous. These requirements do not apply to the purchases of supplies or materials or articles ordinarily available on the open market, or contracts for transportation or transmission of intelligence.

- D. Rights to Inventions Made Under a Contract or Agreement. If the Federal award meets the definition of "funding agreement" under 37 C.F.R § 401.2(a) and the recipient or subrecipient (sponsor) wishes to enter into a contract with a small business firm or nonprofit organization regarding the substitution of parties, assignment or performance of experimental, developmental, or research work under that "funding agreement," the recipient or subrecipient (sponsor) must comply with the requirements of 37 C.F.R Part 401, "Rights to Inventions Made by Nonprofit Organizations and Small Business Firms Under Government Grants, Contracts and Cooperative Agreements," and any implementing regulations issued by the awarding agency.
- E. Clean Air Act (42 U.S.C. 7401-7671q.) and the Federal Water Pollution Control Act (33 U.S.C. 1251-1387), as Amended. Contracts and subgrants of amounts in excess of \$150,000 must contain a provision that requires the non-Federal award to agree to comply with all applicable standards, orders or regulations issued pursuant to the Clean Air Act (42 U.S.C. 7401-7671q) and the Federal Water Pollution Control Act as amended (33 U.S.C. 1251-1387). Violations must be reported to the Federal awarding agency identified in Section G: Federal Fund Information and the Regional Office of the Environmental Protection Agency (EPA).
- F. Byrd Anti-Lobbying Amendment (31 U.S.C. 1352). Contractors that apply or bid for an award exceeding \$100,000 must file the required certification. Each tier certifies to the tier above that it will not and has not used Federal appropriated funds to pay any person or organization for influencing or attempting to influence an officer or employee of any agency, a member of Congress, officer or employee of Congress, or an employee of a member of Congress in connection with obtaining any Federal contract, grant or any other award covered by 31 U.S.C. 1352. Each tier must also disclose any lobbying with non-Federal funds that takes place in connection with obtaining any Federal award. Such disclosures are forwarded from tier to tier up to the non-Federal award.
- G. Procurement of Recovered Materials. A non-Federal entity (sponsor) that is a state agency or agency of a political subdivision of a state and its contractors must comply with section 6002 of the Solid Waste Disposal Act, as amended by the Resource Conservation and Recovery Act. The requirements of Section 6002 include procuring only items designated in guidelines of the Environmental Protection Agency (EPA) at 40 C.F.R part 247 that contain the highest percentage of recovered materials practicable, consistent with maintaining a satisfactory level of competition, where the purchase price of the item exceeds \$10,000 or the value of the quantity acquired during the preceding fiscal year exceeded \$10,000; procuring solid waste management services in a manner that maximizes energy and resource recovery; and establishing an affirmative procurement program for procurement of recovered materials identified in the EPA guidelines.
- H. Required Insurance. The non-Federal entity (sponsor) must, at a minimum, provide the equivalent insurance coverage for real property and equipment acquired or improved with Federal funds as provided to property owned by the non-Federal entity. Federally-owned property need not be insured unless required by the terms and conditions of the Federal award (2 C.F.R § 200.310 (2013)).
- I. Debarment and Suspension (Executive Orders 12549 and 12689). The sponsor must not award a contract (see 2 C.F.R § 180.220) to parties listed on the government-wide exclusions in the System for Award Management (SAM), in accordance with the Office of Management and Budget (OMB) guidelines at 2 C.F.R § 180 that implement Executive Orders 12549 (3 C.F.R part 1986 Comp., p. 189) and 12689 (3 C.F.R part 1989 Comp., p. 235), "Debarment and Suspension." SAM Exclusions contains the names of parties debarred, suspended, or otherwise excluded by agencies, as well as parties declared ineligible under statutory or regulatory authority other than Executive Order 12549.

SECTION 28. PROVISIONS FOR FIREARMS AND ARCHERY RANGE RECREATION PROJECTS ONLY

The following provisions shall be in force only if the project described in this Agreement is funded from the Firearms and Archery Range Recreation Account.

- A. **Liability Insurance.** The sponsor of a firearms or archery range recreation project shall procure an endorsement, or other addition, to liability insurance it may currently carry, or shall procure a new policy of liability insurance, in a total coverage amount the sponsor deems adequate to ensure it will have resources to pay successful claims of persons who may be killed or injured, or suffer damage to property, while present at the range facility to which this grant is related, or by reason of being in the vicinity of that facility; provided that the coverage shall be at least one million dollars (\$1,000,000) for the death of, or injury to, each person.
- B. **Insurance Endorsement.** The liability insurance policy, including any endorsement or addition, shall name Washington State, the funding board, and RCO as additional insured and shall be in a form approved by the funding board or director.
- C. **Length of Insurance.** The policy, endorsement or other addition, or a similar liability insurance policy meeting the requirements of this section, shall be kept in force throughout the sponsor's obligation to the project as identified in this Agreement in Section E: On-going Obligation.
- D. **Notice of Cancellation.** The policy, as modified by any endorsement or other addition, shall provide that the issuing company shall give written notice to RCO not less than thirty (30) calendar days in advance of any cancellation of the policy by the insurer, and within ten (10) calendar days following any termination of the policy by the sponsor.
- E. **Government Agencies.** The requirement of Subsection A through D above shall not apply if the sponsor is a federal, state, or municipal government which has established a program of self-insurance or a policy of self-insurance with respect to claims arising from its facilities or activities generally, including such facilities as firearms or archery ranges, when the applicant declares and describes that program or policy as a part of its application to the funding board.
- F. **Sole Duty of the Sponsor.** By this requirement, the funding board and RCO does not assume any duty to any individual person with respect to death, injury, or damage to property which that person may suffer while present at, or in the vicinity of, the facility to which this grant relates. Any such person, or any other person making claims based on such death, injury, or damage, must look to the sponsor, or others, for any and all remedies that may be available by law.

SECTION 29. PROVISIONS FOR LAND AND WATER CONSERVATION FUND PROJECTS ONLY

The following provisions shall be in force only if the project described in this Agreement is funded from the Land and Water Conservation Fund.

If the project has been approved by the National Park Service, US Department of the Interior, for funding assistance from the federal Land and Water Conservation Fund (LWCF), the "Project Agreement General Provisions" in the LWCF State Assistance Program Federal Financial Assistance Manual are also made part of this Agreement and incorporated herein. The sponsor shall abide by these LWCF General Provisions, in addition to this Agreement, as they now exist or are hereafter amended. Further, the sponsor agrees to provide RCO with reports or documents needed to meet the requirements of the LWCF General Provisions.

SECTION 30. PROVISIONS FOR FARMLAND PRESERVATION ACCOUNT PROJECTS ONLY

The following provisions shall be in force only if the project described in this Agreement is funded from the Washington Wildlife and Recreation Program Farmland Preservation Account.

For projects funded through the Washington Wildlife and Recreation Program Farmland Preservation Account, the following sections will not apply if covered separately in a recorded RCO approved Agricultural Conservation Easement:

- A. Section 15 - Income and Income Use;
- B. Section 19 - Stewardship and Monitoring;
- C. Section 21 - Acknowledgement and Signs;
- D. Section 23 - Provisions applying to Acquisition Projects, Sub-sections D, F, and G;
- E. Section 24 - Restriction on Conversion of Real Property and/or Facilities to Other Uses; and
- F. Section 25 - Construction, Operation and Maintenance of Assisted Projects.

SECTION 31. PROVISIONS FOR SALMON RECOVERY FUNDING BOARD PROJECTS ONLY

The following provisions shall be in force only if the project described in this Agreement is funded by the SRFB.

For habitat restoration projects funded in part or whole with federal funds administered by the SRFB the sponsor shall not commence with clearing of riparian trees or in-water work unless either the sponsor has complied with 50 C.F.R. § 223.203 (b)(8) (2000), limit 8 or until an Endangered Species Act consultation is finalized in writing by the National Oceanic and Atmospheric Administration. Violation of this requirement may be grounds for terminating this project Agreement. This section shall not be the basis for any enforcement responsibility by RCO.

SECTION 32. PROVISIONS FOR PUGET SOUND ACQUISITION AND RESTORATION PROJECTS ONLY

The following provisions shall be in force only if the project described in this Agreement is funded from the Puget Sound Acquisition and Restoration program.

The sponsor agrees to the following terms and conditions:

- A. **Cost Principles/Indirect Costs for State Agencies.** Sub-Recipient (sponsor) will comply with the cost principles of 2 C.F.R. Part 200 Subpart E (2013). Unless otherwise indicated, the cost principles apply to the use of funds provided under this Agreement and in-kind matching donations. The applicability of the cost principles depends on the type of organization incurring the costs.
- B. **Sub-recipient (sponsor) shall meet the provisions in Office of Management and Budget (OMB) Guidance, Subpart F, §200.501 (Audit Requirements),** if the sponsor expends \$750,000 or more in total Federal funds in a fiscal year. The \$750,000 threshold for each year is a cumulative total of all federal funding from all sources. The sponsor shall forward a copy of the audit along with the sponsor's response and the final corrective action plan to RCO within ninety (90) days of the date of the audit report. For complete information on how to accomplish the single audit submissions, visit the Federal Audit Clearinghouse Web site: <http://harvester.census.gov/facweb>
- C. **Credit and Acknowledgement.** In addition to Section 21: Acknowledgement and Signs, materials produced must display both the Environmental Protection Agency (EPA) and Puget Sound Partnership (PSP) logos and the following credit line: "This project has been funded wholly or in part by the United States Environmental Protection Agency. The contents of this document do not necessarily reflect the views and policies of the Environmental Protection Agency, nor does mention of trade names or commercial products constitute endorsement or recommendation for use." This requirement is for the life of the product, whether during or after the Agreement period of performance.
- D. **Hotel Motel Fire Safety Act.** Sponsor agrees to ensure that all conference, meeting, convention, or training space funded in whole or part with federal funds, complies with the federal Hotel and Motel Fire Safety Act (PL 101-391, as amended). Sponsors may search the Hotel-Motel National Master List @ <http://www.usfa.dhs.gov/applications/hotel> to see if a property is in compliance or to find other information about the Act.
- E. **Drug Free Workplace Certification.** Sub-recipient (sponsor) shall make an ongoing, good faith effort to maintain a drug-free workplace pursuant to the specific requirements set forth in 2 C.F.R. Part 1536 Subpart B. Additionally, in accordance with these regulations, the recipient organization shall identify all known workplaces under its federal awards, and keep this information on file during the performance of the award. Sponsors who are individuals must comply with the drug-free provisions set forth in 2 C.F.R. Part 1536 Subpart C. The consequences for violating this condition are detailed under 2 C.F.R. Part 1536 Subpart E. Recipients can access the Code of Federal Regulations (CFR) Title 2 Part 1536 at: <http://ecfr.gpoaccess.gov>.
- F. **Management Fees.** Management fees or similar charges in excess of the direct costs and approved indirect rates are not allowable. The term "management fees or similar charges" refers to the expenses added to direct costs in order to accumulate and reserve funds for ongoing business expenses, unforeseen liabilities or for other similar costs which are not allowable. Management fees or similar charges may not be used to improve or expand the project funded under this agreement, except for the extent authorized as a direct cost of carrying out the scope of work.
- G. **Trafficking in Persons and Trafficking Victim Protection Act of 2000 (TVPA).** This provision applies only to a Sub-recipient (sponsor), and all sub-awardees of sub-recipient (sponsor), if any. Sub-recipient (sponsor) shall include the following statement in all sub-awards made to any private entity under this Agreement.

"You as the sub-recipient, your employees, sub-awardees under this award, and sub-awardees' employees may not engage in severe forms of trafficking in persons during the period of time that the award is in effect; procure a commercial sex act during the period of time that the award is in effect; or use forced labor in the performance of the award or sub-awards under this Award."

Sub-recipient (sponsor), and all sub-awardees of sub-recipient (sponsor) must inform RCO immediately of any information you receive from any source alleging a violation of this prohibition during the award term.

Federal agency funding this agreement may unilaterally terminate, without penalty, the funding award if this prohibition is violated, Section 106 of the Trafficking Victims Protection Act of 2000, as amended.

- H. **Lobbying.** The chief executive officer of this recipient agency (sponsor) shall ensure that no grant funds awarded under this assistance agreement are used to engage in lobbying of the Federal Government or in litigation against the U.S. unless authorized under existing law. The recipient (sponsor) shall abide by their respective Cost Principles (OMB Circulars A-21, A-87, and A-122), which generally prohibits the use of federal grant funds for litigation against the U. S. or for lobbying or other political activities.

The sponsor agrees to comply with 40 C.F.R. Part 34, New Restrictions on Lobbying. Sponsor shall include the language of this provision in award documents for all sub-awards exceeding \$100,000, and require that sub-awardees submit certification and disclosure forms accordingly.

In accordance with the Byrd Anti-Lobbying Amendment, any sponsor who makes a prohibited expenditure under 40 C.F.R. Part 34 or fails to file the required certification or lobbying forms shall be subject to a civil penalty of not less than \$10,000 and not more than \$100,000 for each expenditure.

All contracts awarded by sponsor shall contain, when applicable, the anti-lobbying provisions as stipulated in the Appendix at 40 C.F.R. Part 30.

Pursuant to Section 18 of the Lobbying Disclosure Act, sponsor affirms that it is not a non-profit organization described in Section 501(c)(4) of the Internal Revenue Code of 1986; or that it is a non-profit organization described in Section 501(c)(4) of the Code but does not and will not engage in lobbying activities as defined in Section 3 of the Lobbying Disclosure Act.

- I. Reimbursement Limitation. If the sponsor expends more than the amount of RCO funding in this Agreement in anticipation of receiving additional funds from the RCO, it does so at its own risk. RCO is not legally obligated to reimburse the sponsor for costs incurred in excess of the RCO approved budget.
- J. Disadvantaged Business Enterprise Requirements. Sponsor agrees to comply with the requirements of EPA's Utilization of Small, Minority and Women's Business Enterprises in procurements made under this award.
- K. Minority and Women's Business Participation. Sponsor agrees to solicit and recruit, to the maximum extent possible, certified minority owned (MBE) and women owned (WBE) businesses in purchases and contracts initiated after the effective date of this Agreement.

These goals are expressed as a percentage of the total dollars available for the purchase or Agreement and are as follows:

Purchased Goods 8% MBE 4% WBE
 Purchased Services 10% MBE 4% WBE
 Professional Services 10% MBE 4% WBE

Meeting these goals is voluntary and no Agreement award or rejection shall be made based on achievement or non-achievement of the goals. Achievement of the goals is encouraged, however, and sponsor and ALL prospective bidders or persons submitting qualifications shall take the following affirmative steps in any procurement initiated after the effective date of this Agreement:

1. Include qualified minority and women's businesses on solicitation lists.
 2. Assure that qualified minority and women's business are solicited whenever they are potential sources of services or supplies.
 3. Divide the total requirements, when economically feasible, into smaller tasks or quantities, to permit maximum participation by qualified minority and women's businesses.
 4. Establish delivery schedules, where work requirements permit, which will encourage participation of qualified minority and women's businesses.
 5. Use the services and assistance of the State Office of Minority and Women's Business Enterprises (OMWBE) and the Office of Minority Business Enterprises of the U.S. Department of Commerce, as appropriate.
- L. MBE/WBE Reporting. In accordance with the deviation from 40 C.F.R. §33.502, signed November 8, 2013, DBE reporting is limited to annual reports and only required for assistance agreements where one or more the following conditions are met:
 1. There are any funds budgeted in the contractual/services, equipment or construction lines of the award;
 2. \$3,000 or more is included for supplies; or
 3. There are funds budgeted for subawards or loans in which the expected budget(s) meet the conditions as
 4. Described in items (a) and (b).

When completing the form, recipients (sponsors) should disregard the quarterly and semi-annual boxes in the reporting period section 1B of the form. For annual submissions, the reports are due by October 30th of each year or 90 days after the end of the project period, whichever comes first.

The reporting requirement is based on planned procurements. Recipients (sponsors) with funds budgeted for non-supply procurement and/or \$3,000 or more in supplies are required to report annually whether the planned procurements take place during the reporting period or not. If no procurements take place during the reporting period, the recipient should check the box in section 5B when completing the form.

MBE/WBE reports should be sent to the DBE Coordinator in the sponsor's region. Contact information can be found at <http://www.epa.gov/osbp/contactpage.htm>. The coordinators can also answer any questions.

Final MBE/WBE reports must be submitted within 90 days after the project period of the grant ends. To be in compliance with regulations, the sponsor must submit a final MBE/WBE report.

Non-compliance may impact future competitive grant proposals. The current EPA Form 5700-52A can be found at the EPA Office of Small Business Program's Home Page at http://www.epa.gov/osbp/dbe_reporting.htm.

- M. SIX GOOD FAITH EFFORTS, 40 C.F.R., Part 33, Subpart C. Pursuant to 40 C.F.R. § 33.301, the sponsor agrees to make the following good faith efforts whenever procuring construction, equipment, services and supplies under an EPA financial assistance agreement, and to require that sub-recipients (sponsors), and prime contractors also comply. Records documenting compliance with the six good faith efforts shall be retained:
 1. Ensure Disadvantaged Business Enterprise (DBEs) are made aware of contracting opportunities to the fullest extent practicable through outreach and recruitment activities. For Indian Tribal, State and Local and Government sponsors, this will include placing DBEs on solicitation lists and soliciting them whenever they are potential sources.
 2. Make information on forthcoming opportunities available to DBEs and arrange time frames for contracts and establish delivery schedules, where the requirements permit, in a way that encourages and facilitates participation by DBEs in the competitive process. This includes, whenever possible, posting solicitations for bids or proposals for a minimum of 30 calendar days before the bid or proposal closing date.
 3. Consider in the contracting process whether firms competing for large contracts could subcontract with DBEs. For Indian Tribal, State and local Government sponsors, this will include dividing total requirements when economically feasible into smaller tasks or quantities to permit maximum participation by DBEs in the competitive process.

4. Encourage contracting with a consortium of DBEs when an Agreement is too large for one of these firms to handle individually.
5. Use the services and assistance of the Small Business Administration (SBA) and the Minority Business Development of the Department of Commerce.
6. If the sponsor awards subcontracts, require the sponsor to take the steps in paragraphs (1) through (5) of this section.

- N. **Lobbying & Litigation.** By signing this agreement, the sponsor certifies that none of the funds received from this agreement shall be used to engage in the lobbying of the Federal Government or in litigation against the United States unless authorized under existing law.

The chief executive officer of this sponsor agency shall ensure that no grant funds awarded under this assistance agreement are used to engage in lobbying of the Federal Government or in litigation against the United States unless authorized under existing law. The sponsor shall abide by its respective Attachment in 2 C.F.R. Part 200, which prohibits the use of Federal grant funds for litigation against the United States or for lobbying or other political activities.

For subawards exceeding \$100,000, EPA requires the following certification and disclosure forms:

Certification Regarding Lobbying, EPA Form 6600-06: http://www.epa.gov/ogd/AppKit/form/Lobbying_sec.pdf

Disclosure of Lobbying Activities, SF LLL: http://www.epa.gov/ogd/AppKit/form/sfillin_sec.pdf

Legal expenses required in the administration of Federal programs are allowable. Legal expenses for prosecution of claims against the Federal Government are unallowable.

- O. **Payment to Consultants.** EPA participation in the salary rate (excluding overhead) paid to individual consultants retained by recipients (sponsors) or by a recipients' (sponsor's) contractors or subcontractors shall be limited to the maximum daily rate for Level IV of the Executive Schedule (formerly GS-18), to be adjusted annually. This limit applies to consultation services of designated individuals with specialized skills who are paid at a daily or hourly rate. This rate does not include transportation and subsistence costs for travel performed (the recipient will pay these in accordance with their normal travel reimbursement practices).

Subagreements with firms for services which are awarded using the procurement requirements in 40 C.F.R. Parts 30 or 31, are not affected by this limitation unless the terms of the contract provide the recipient (sponsor) with responsibility for the selection, direction and control of the individual who will be providing services under the contract at an hourly or daily rate of compensation. See 40 C.F.R. § 30.27(b) or 40 C.F.R. § 31.369(j), as applicable, for additional information.

As of January 1, 2014, the limit is \$602.24 per day \$75.28 per hour.

- P. **Peer Review.** Where appropriate, prior to finalizing any significant technical products the Principal Investigator (PI) of this project must solicit advice, review, and feedback from a technical review or advisory group consisting of relevant subject matter specialists. A record of comments and a brief description of how respective comments are addressed by the PI will be provided to the Project Monitor prior to releasing any final reports or products resulting from the funded study.

SECTION 33. PROVISIONS FOR ESTUARY AND SALMON RESTORATION PROGRAM - EPA AND MARINE SHORELINE

The following provisions shall be in force only if the project described in this Agreement is funded from the Estuary and Salmon Restoration Program - EPA or the Marine Shoreline Protection program.

The sponsor shall comply with all applicable federal, State, and local laws, rules, and regulations in carrying out the terms and conditions of this Agreement.

A. Administrative Conditions

1. **Cost Principles.** The sponsor agrees to comply with the cost principles of 2 C.F.R Part 200 (2013). Unless otherwise indicated, the Cost Principles apply to the use of funds provided under this Agreement and In-kind matching donations. The applicability of the Cost Principles depends on the type of organization incurring the costs.
2. **Audit Requirements.** The sponsor shall fully comply with requirements of 2 C.F.R. Part 200, Subpart F- Audit Requirements (2013), if applicable. See also Section F: Project Funding.
3. **Hotel-Motel Fire Safety Act.** Pursuant to 40 C.F.R. 30.18, if applicable, and 15 U.S.C 2225a, sponsor agrees to ensure that all space for conferences, meetings, conventions, or training seminars funded in whole or in part with federal funds complies with the protection and control guidelines of the Hotel and Motel Fire Safety Act (PL 101-391, as amended). The sponsor may search the Hotel-Motel National Master List at: <http://www.usfa.dhs.gov/applications/hotel> to see if a property is in compliance (FEMA ID is currently not required), or to find other information about the Act.
4. **Recycled Paper**
 - a. **Institutions of Higher Education Hospitals and Non-Profit Organizations.** In accordance with 40 C.F.R. 30.16, sponsor agrees to use recycled paper and double-sided printing for all reports which are prepared as a part of this Agreement and delivered to EPA. This requirement does not apply to reports prepared on forms supplied by EPA, or to Standard Forms, which are printed on recycled paper and are available through the General Services Administration.

- b. State Agencies and Political Subdivisions. In accordance with Section 6002 of the Resource Conservation and Recovery Act (RCRA) (42 U.S.C. 6962) any State agency or agency of a political subdivision of a State which is using appropriated Federal funds shall comply with the requirements set forth. Regulations issued under RCRA Section 6002 apply to any acquisition of an item where the purchase price exceeds \$10,000 or where the quantity of such items acquired in the course of the preceding fiscal year was \$10,000 or more. RCRA Section 6002 requires that preference be given in procurement programs to the purchases of specific products containing recycled materials identified in guidelines developed by EPA. These guidelines are listed in 40 C.F.R. 247.
 - c. State and Local Institutions of Higher Education and Non-Profit Organizations. In accordance with 40 C.F.R. § 30.16, State and local institutions of higher education, hospitals, and non-profit organizations that receive direct Federal funds shall give preference in their procurement programs funded with Federal funds to the purchase of recycled products pursuant to EPA's guidelines.
 - d. State Tribal and Local Government Recipients. In accordance with the policies set forth in EPA Order 1000.25 and Executive Order 13423, Strengthening Federal Environmental, Energy and Transportation Management (January 24, 2007), the sponsor agrees to use recycled paper and double sided printing for all reports which are prepared a part of this Agreement and delivered to EPA. This requirement does not apply to reports prepared on forms supplied by EPA, or to Standard Forms, which are printed on recycled paper and are available through the General Services Administration.
5. Lobbying. The sponsor agrees to comply with Title 40 C.F.R. Part 34, New Restrictions on Lobbying. The sponsor shall include the language of this provision in award documents for all sub-awards exceeding \$100,000, and require that sub-awardees submit certification and disclosure forms accordingly.

In accordance with the Byrd Anti-Lobbying Amendment, any recipient who makes a prohibited expenditure under Title 40 C.F.R. Part 34 or fails to file the required certification or lobbying forms shall be subject to a civil penalty of not less than \$10,000 and not more than \$100,000 for each expenditure. See also Section 11: Compliance with Applicable Federal Laws.

- a. Part 30 Recipients. All contracts awarded by the sponsor shall contain, when applicable, the anti-lobbying provisions as stipulated in the Appendix at Title 40 CFR Part 30.

Pursuant to Section 18 of the Lobbying Disclosure Act, the sponsor affirms that it is not a non-profit organization described in Section 501(c)(4) of the Internal Revenue Code of 1986; or that it is a non-profit organization described in Section 501(c)(4) of the Code but does not and will not engage in lobbying activities as defined in Section 3 of the Lobbying Disclosure Act.
 - b. Lobbying and Litigation. The sponsor's chief executive officer shall ensure that no grant funds awarded under this Agreement are used to engage in lobbying of the Federal Government or in litigation against the United States unless authorized under existing law. The sponsor shall abide by its respective Appendix in 2 C.F.R. Part 200, which prohibits the use of Federal grant funds for litigation against the United States or for lobbying or other political activities.
6. Suspension and Debarment. The sponsor shall fully comply with Subpart C of 2 C.F.R. Part 180 and 2 C.F.R. Part 1532, entitled 'Responsibilities of Participants Regarding Transaction (Doing Business with Other Persons)'. The sponsor is responsible for ensuring that any lower tier covered transaction as described in Subpart B of 2 C.F.R. Part 180 and 2 C.F.R. Part 1532, entitled 'Covered Transactions', includes a term or condition requiring compliance with Subpart C. The sponsor is responsible for further requiring the inclusion of a similar term or condition in any subsequent lower tier covered transactions. The sponsor acknowledges that failing to disclose the information as required at 2 C.F.R. § 180.335 may result in the delay or negation of this assistance agreement, or pursuance of legal remedies, including suspension and debarment.

The sponsor may access the Excluded Parties List System at: <http://www.epis.gov>. This term and condition supersedes EPA Form 5700-49, 'Certification Regarding Debarment, Suspension, and Other Responsibility Matters'. See also Section 27: Provisions for Federal Subawards Only.

- 7. Drug-Free Workplace Certification. The sponsor must make an ongoing, good faith effort to maintain a drug-free workplace pursuant to the specific requirements set forth in 2 C.F.R. Part 1536 Subpart B. Additionally, in accordance with these regulations, the sponsor must identify all known workplaces under its federal award; and keep this information on file during the performance of the award.
 - a. Sponsors who are individuals must comply with the drug-free provisions set forth in 2-C.F.R. Part 1536 Subpart C.
 - b. The consequences for violating this condition are detailed under 2 C.F.R. Part 1536 Subpart E. The sponsor can access 2 C.F.R Part 1536 at <http://ecfr.gpoaccess.gov>.
- 8. Management Fees. Management fees or similar charges in excess of the direct costs and approved indirect rates are not allowable. The term "management fees or similar charges" refers to expenses added to the direct costs in order to accumulate and reserve funds for ongoing business expenses, unforeseen liabilities, or for other similar costs which are not allowable under this assistance agreement. Management fees or similar charges may not be used to improve or expand the project funded under this Agreement, except to the extent authorized as a direct cost of carrying out the scope of work.
- 9. Reimbursement Limitation. If the sponsor expends more than the grant amount in this Agreement in its approved budget in anticipation of receiving additional funds, it does so at its own risk. The Federal Government and RCO is not legally obligated to reimburse the sponsor for costs incurred in excess of the approved budget. See also Section 11: Project Reimbursements.

10. Trafficking in Persons. The following prohibition statement applies to the sponsor, and all sub-awardees of the sponsor. The sponsor must include this statement in all sub-awards made to any private entity under this Agreement.
- "YOU AS THE SUB-RECIPIENT, YOUR EMPLOYEES, SUB-AWARDEES UNDER THIS AWARD, AND SUB-AWARDEES' EMPLOYEES MAY NOT ENGAGE IN SEVERE FORMS OF TRAFFICKING IN PERSONS DURING THE PERIOD OF TIME THAT THE AWARD IS IN EFFECT; PROCURE A COMMERCIAL SEX ACT DURING THE PERIOD OF TIME THAT THE AWARD IS IN EFFECT; OR USE FORCED LABOR IN THE PERFORMANCE OF THE AWARD OR SUB-AWARDS UNDER THIS AWARD."
11. Disadvantaged Business Enterprise Requirements, General Compliance. The sponsor agrees to comply with the requirements of EPA's Program for Utilization of Small, Minority and Women's Business Enterprises in procurement under assistance agreements, contained in 40 C.F.R. Part 33.
12. Sub-Awards. If the sponsor makes sub-awards under this Agreement, the sponsor is responsible for selecting its sub-awardees and, if applicable, for conducting sub-award competitions. The sponsor agrees to:
- Establish all sub-award agreements in writing;
 - Maintain primary responsibility for ensuring successful completion of the approved project (SPONSORS CANNOT DELEGATE OR TRANSFER THIS RESPONSIBILITY TO A SUB-AWARDEE);
 - Ensure that any sub-awards comply with the standards in 2 C.F.R. Part 200, and are not used to acquire commercial goods or services for the sub-awardee;
 - Ensure that any sub-awards to 501(c)(4) organizations do not involve lobbying activities;
 - Monitor the performance of sub-awardees, and ensure sub-awardees comply with all applicable regulations, statutes, and terms and conditions which flow down in the sub-award;
 - Obtain RCO's consent before making a sub-award to a foreign or international organization, or a sub-award to be performed in a foreign country; and
 - Obtain approval from RCO for any new sub-award work that is not outlined in the approved work plan in accordance with 40 C.F.R. Parts 30.25 and 31.30, as applicable.
13. Federal Employees. No Subcontract or grant funds may be used to provide any Federal Employee transportation assistance, reimbursement, and any other expense.
14. Fly America Act. The sponsor agrees to comply with 49 U.S.C. 40118 (the "Fly America" act) in accordance with the General Services Administration's regulations at 41 C.F.R. Part 301-10, which provide that recipients and subrecipients of Federal funds and their contractors are required to use U.S. Flag air carriers for U.S. Government-financed international air travel and transportation of their personal effects or property, to the extent such service is available, unless travel by foreign air carrier is a matter of necessity, as defined by the Fly America Act. The sponsor shall submit, if a foreign air carrier was used, an appropriate certification or memorandum adequately explaining why service by U.S. flag air carrier was not available or why it was necessary to use a foreign air carrier and shall, in any event, provide a certificate of compliance with the Fly America requirements. The sponsor agrees to include the requirements of this section in all subcontracts that may involve international air transportation.
15. Recovered Materials. The sponsor agrees to comply with all the requirements of Section 6002 of the Resource Conservation and Recovery Act (RCRA), as amended (42 U.S.C. 6962), including but not limited to the regulatory provisions of 40 C.F.R. Part 247, and Executive Order 12873, as they apply to the procurement of the items designated in Subpart B of 40 C.F.R. Part 247. See also Section 27: Provisions for Federal Subawards Only.
16. Copeland "Anti-Kickback" Act. All contracts and subgrants in excess of \$2,000 for construction or repair awarded by recipients and subrecipients shall include a provision for compliance with the Copeland "Anti-Kickback" Act (18 U.S.C. 874), as supplemented by Department of Labor regulations (29 C.F.R. Part 3, "Contractors and Subcontractors on Public Building or Public Work Financed in Whole or in Part by Loans or Grants from the United States"). The Act provides that each contractor or subrecipient shall be prohibited from inducing, by any means, any person employed in the construction, completion, or repair of public work, to give up any part of the compensation to which he is otherwise entitled. The recipient shall report all suspected or reported violations to the Federal awarding agency. See also Section 27: Provisions for Federal Subawards Only.
17. Davis-Bacon Act, as amended (40 U.S.C. 276a to a-7). When required by Federal program legislation, all construction contracts awarded by the recipients and subrecipients of more than \$2,000 shall include a provision for compliance with the Davis-Bacon Act (40 U.S.C. 276a to a-7) and as supplemented by Department of Labor regulations (29 C.F.R. Part 5, "Labor Standards Provisions Applicable to Contracts Governing Federally Financed and Assisted Construction"). Under this Act, contractors shall be required to pay wages to laborers and mechanics at a rate not less than the minimum wages specified in a wage determination made by the Secretary of Labor. In addition, contractors shall be required to pay wages not less than once a week. The recipient shall place a copy of the current prevailing wage determination issued by the Department of Labor in each solicitation and the award of a contract shall be conditioned upon the acceptance of the wage determination. The recipient shall report all suspected or reported violations to the Federal awarding agency. See also Section 27: Provisions for Federal Subawards Only.

18. **Contract Work Hours and Safety Standards Act (40 U.S.C. 327-333).** Where applicable, all contracts awarded by recipients in excess of \$2000 for construction contracts and in excess of \$2,500 for other contracts that involve the employment of mechanics or laborers shall include a provision for compliance with Sections 102 and 107 of the Contract Work Hours and Safety Standards Act (40 U.S.C. 327-333), as supplemented by Department of Labor regulations (29 C.F.R. Part 5). Under Section 102 of the Act, each contractor shall be required to compute the wages of every mechanic and laborer on the basis of a standard work week of 40 hours. Work in excess of the standard work week is permissible provided that the worker is compensated at a rate of not less than 1 1/2 times the basic rate of pay for all hours worked in excess of 40 hours in the work week. Section 107 of the Act is applicable to construction work and provides that no laborer or mechanic shall be required to work in surroundings or under working conditions which are unsanitary, hazardous or dangerous. These requirements do not apply to the purchases of supplies or materials or articles ordinarily available on the open market, or contracts for transportation or transmission of intelligence. See also Section 27: Provisions for Federal Subawards Only.
19. **Rights to Inventions Made Under a Contract or Agreement.** Contracts or agreements for the performance of experimental, developmental, or research work shall provide for the rights of the Federal Government and the recipient in any resulting invention in accordance with 37 C.F.R. Part 401, "Rights to Inventions made by Nonprofit Organizations and Small Business Firms Under Government Grants, Contracts and Cooperative Agreements," and any implementing regulations issued by the awarding agency. See also Section 27: Provisions for Federal Subawards Only.
20. **FY12 APPR ACT: Unpaid Federal Tax liabilities and Federal Felony Convictions.** This Agreement is subject to the provisions contained in the Department of Interior, Environment, and Related Agencies Appropriations Act, 2012, HR 2055, Division E, Sections 433 and 434 regarding unpaid federal tax liabilities and federal felony convictions. Accordingly, by accepting this award the recipient acknowledges that it (1) is not subject to any unpaid Federal tax liability that has been assessed, for which all judicial and administrative remedies have been exhausted or have lapsed, and that is not being paid in a timely manner pursuant to an agreement with the authority responsible for collecting the tax liability, and (2) has not been convicted (or had an officer or agent acting on its behalf convicted) of a felony criminal conviction under and Federal law within 24 months preceding the award, unless EPA has considered suspension or debarment of the corporation, or such officer or agent, based on these tax liabilities or convictions and determined that such action is not necessary to such action is not necessary to protect the Government's interests. If the recipient fails to comply with these provisions, EPA will annul this agreement and may recover any funds the recipient has expended in violation of sections 433 and 434.

B. Programmatic Conditions:

1. **Semi-Annual FEATS Performance Reports.** The sponsor is required to submit performance reports every six months, unless a different reporting frequency is outlined in the Scope of Work, using the reporting tool supplied by RCO. The sponsor agrees to include brief information on each of the following areas:
 - a. Comparison of actual accomplishments to the outputs/outcomes established in the assistance agreement work plan for the period;
 - b. The reasons for slippages if the established outputs/outcomes were not met; AND
 - c. Additional pertinent information, including when appropriate, analysis and information of cost overruns or high unit costs.

Reporting periods are from October 1 to March 31 and April 1 to September 30. Performance reports are due to RCO 15 days after the end of each reporting period.

2. **Final Performance Report.** In addition to the periodic performance reports, the sub-recipient will submit a final performance report to RCO within 60 calendar days after the expiration or termination of the award. The report shall be submitted to the RCO Grant Manager and must be provided electronically. The report shall generally contain the same information as in the periodic reports, but should cover the entire project period.
3. **Recognition of EPA Funding.** Reports, documents, signage, videos, or other media, developed as part of projects funded by this Agreement shall contain the following statement:

"THIS PROJECT HAS BEEN FUNDED WHOLLY OR IN PART BY THE UNITED STATES ENVIRONMENTAL PROTECTION AGENCY UNDER ASSISTANCE AGREEMENT TO WASHINGTON DEPARTMENT OF FISH AND WILDLIFE. THE CONTENTS OF THIS DOCUMENT DO NOT NECESSARILY REFLECT THE VIEWS AND POLICIES OF THE ENVIRONMENTAL PROTECTION AGENCY, NOR DOES MENTION OF TRADE NAMES OR COMMERCIAL PRODUCTS CONSTITUTE ENDORSEMENT OR RECOMMENDATION FOR USE."

4. **Copyrighted Material.** EPA has the right to reproduce, publish, use, and authorize others to use copyrighted works or other data developed under this assistance agreement for Federal purposes.

RCO acknowledges that EPA may authorize another grantee to use copyrighted works or other data developed under this Agreement as a result of: a) the selection of another grantee by EPA to perform a project that will involve the use of the copyrighted works or other data or; b) termination or expiration of this agreement.

5. **Peer Review.** The results of this project may affect management decisions relating to Puget Sound. Prior to finalizing any significant technical products the Principal Investigator (PI) of this project must solicit advice, review and feedback from a technical review or advisory group consisting of relevant subject matter specialists. A record of comments and a brief description of how respective comments are addressed by the PI will be provided to the RCO Grants Manager prior to releasing any final reports or products resulting from the funded study.

6. **Quality Assurance Requirements.** Acceptable Quality Assurance documentation must be submitted to the Grant Program within 30 days of acceptance of this agreement or another date as negotiated with the RCO Grants Manager. The National Estuary Program (NEP) Quality Coordinator supports quality assurance for EPA-funded NEP projects. No work involving direct measurements or data generation, environmental modeling, compilation of data from literature or electronic media, and data supporting the design, construction, and operation of environmental technology shall be initiated under an agreement until RCO or the NEP Quality Coordinator has approved the quality assurance document. The sponsor will submit all Quality Assurance documentation to the following address. Please copy the Grant Program on all correspondence with the NEP Quality Coordinator. Thomas H. Gries, NEP Quality Coordinator Department of Ecology Tgri460@ecy.wa.gov 360.407.6327.
7. **Environmental Data and Information Technology.** Sub-recipients are required to institute standardized reporting requirements into their work plans and include such costs in their budgets. All environmental data will be required to be entered into the EPA's Storage and Retrieval data system (STORET). The best method (local or state consolidated) for reporting will be determined on a project-by-project basis between the DFW grant manager and sub-recipient. More information about STORET can be found at <http://www.epa.gov/STORET>.

SECTION 34. PROVISIONS FOR ESTUARY AND SALMON RESTORATION PROGRAM - EPA PROJECTS ONLY

The following provisions shall be in force only if the project described in this Agreement is funded from the Estuary and Salmon Restoration Program - EPA.

A. DUNS and CCR Requirements

1. Unless otherwise exempted from this requirement under 2 C.F.R. § 25.110, the sponsor must maintain the currency of its information in the CCR until submission of its final financial report required under this Agreement or receive the final payment, whichever is later.
2. The sponsor may not make a sub-award to any entity unless the entity has provided its DUNS number to the sponsor.

B. FY2011 ACORN Funding Restriction. No funds provided under this Agreement may be used for sub-awards/sub-grants or contracts to the Association of Community Organizations for Reform NOW (ACORN) or any of its subsidiaries.

SECTION 35. PROVISIONS FOR MARINE SHORELINE PROTECTION PROGRAM PROJECTS ONLY

The following provisions shall be in force only if the project described in this Agreement is funded from the Marine Shoreline Protection program.

The Sub-Recipient shall comply with all applicable federal, State, and local laws, rules, and regulations in carrying out the terms and conditions of this Agreement.

- A. **Federal Finance Report (FFR).** Recipients (sponsor) shall submit final Federal Financial Reports (FFR), Standard Form 425 (SF-425), to EPA no later than 90 calendar days after the end of the project period. The form is available on the internet at www.epa.gov/ocfo/financeservices/forms.htm. All FFRs must be submitted to the Las Vegas Finance Center: US EPA, LVFC, 4220 S. Maryland Pkwy Bldg C, Rm 503, Las Vegas, NV 89119, or by FAX to: 702-798-2423. The LVFC will make adjustments, as necessary, to obligated funds after reviewing and accepting a final Federal Financial Report. Recipients (sponsor) will be notified and instructed by EPA if they must complete any additional forms for the closeout of the assistance agreement. EPA may take enforcement actions in accordance with 40 C.F.R. § 30.62 and 40 C.F.R. § 31.43 if the recipient does not comply with this term and condition.
- B. **Reimbursement Limitation.** If the sponsor expends more than the amount of federal funding in its approved budget in anticipation of receiving additional funds, it does so at its own risk. The Federal Government and RCO is not legally obligated to reimburse Sub-Recipient for costs incurred in excess of the approved budget.
- C. **DUNS and CCR Requirements**
 1. **Requirement for Central Contractor Registration (CCR)/System for Award Management (SAM).** Unless the sponsor is exempted from this requirement under 2 C.F.R. § 25.110, the sponsor must maintain the currency of its information in the SAM until the sponsor submits the final financial report required under this award or receive the final payment, whichever is later. This requires that the sponsor review and update the information at least annually after the initial registration, and more frequently if required by changes in your information or another award term.
 2. **Requirement for Data Universal Numbering System (DUNS) numbers.** If the sponsor is authorized to make subawards under this award, the sponsor:
 - a. Must notify potential subrecipients that no entity may receive a subaward from the sponsor unless the entity has provided its DUNS number to the sponsor.
 - b. May not make a subaward to an entity unless the entity has provided its DUNS number to the sponsor.

3. Definitions. For purposes of this award term:
- a. Central Contractor Registration (CCR)/System for Award Management (SAM) means the Federal repository into which an entity must provide information required for the conduct of business as a recipient. Additional information about registration procedures may be found at the System for Award Management (SAM) Internet site <http://www.sam.gov>.
 - b. Data Universal Numbering System (DUNS) number means the nine-digit number established and assigned by Dun and Bradstreet, Inc. (D&B) to uniquely identify business entities. A DUNS number may be obtained from D&B by telephone (currently 866-705-5711) or the Internet (currently at <http://fedgov.dnb.com/webform>).
 - c. Entity, as it is used in this award term, means all of the following, as defined at 2 C.F.R Part 25, subpart C:
 - i. A Governmental organization, which is a State, local government, or Indian tribe;
 - ii. A foreign public entity;
 - iii. A domestic or foreign nonprofit organization;
 - iv. A domestic or foreign for-profit organization; and
 - v. A Federal agency, but only as a subrecipient under an award or subaward to a non-Federal entity.
 - d. Subaward:
 - i. This term means a legal instrument to provide support for the performance of any portion of the substantive project or program for which you received this award and that you as the recipient award to an eligible subrecipient.
 - ii. The term does not include your procurement of property and services needed to carry out the project or program (for further explanation, see Sec. --.210 of the attachment to OMS Circular A-133, "Audits of States, Local Governments, and Non-Profit Organizations").
 - iii. A subaward may be provided through any legal agreement, including an agreement that you consider a contract.
 - e. Subrecipient means an entity that:
 - i. Receives a subaward from you under this award; and
 - ii. Is accountable to you for the use of the Federal funds provided by the subaward.

D. CIVIL RIGHTS OBLIGATIONS

1. General. This term and condition incorporates by reference the signed assurance provided by the recipient's authorized representative on: 1) EPA Form 4700-4, "Preaward Compliance Review Report for All Applicants and Recipients Requesting EPA Financial Assistance"; and 2) Standard Form 4248 or Standard Form 424D, as applicable. These assurances and this term and condition obligate the recipient to comply fully with applicable civil rights statutes and implementing EPA regulations.
2. Statutory Requirements. In carrying out this agreement, the recipient must comply with:
 - a. Title VI of the Civil Rights Act of 1964, which prohibits discrimination based on race, color, and national origin, including limited English proficiency (LEP), by entities receiving Federal financial assistance.
 - b. Section 504 of the Rehabilitation Act of 1973, which prohibits discrimination against persons with disabilities by entities receiving Federal financial assistance; and
 - c. The Age Discrimination Act of 1975, which prohibits age discrimination by entities receiving
 - d. Federal financial assistance.

If the recipient is conducting an education program under this agreement, it must also comply with Title IX of the Education Amendments of 1972, which prohibits discrimination on the basis of sex in education programs and activities operated by entities receiving Federal financial assistance.

If this agreement is funded with financial assistance under the Clean Water Act (CWA), the recipient must also comply with Section 13 of the Federal Water Pollution Control Act Amendments of 1972, which prohibits discrimination on the basis of sex in CWA-funded programs or activities.

3. Regulatory Requirements. The recipient agrees to comply with all applicable EPA civil rights regulations, including:
 - a. For Title IX obligations, 40 C.F.R. Part 5; and
 - b. For Title VI, Section 504, Age Discrimination Act, and Section 13 obligations, 40 C.F.R. Part 7.
 - c. As noted on the EPA Form 4700-4 signed by the recipient's authorized representative, these regulations establish specific requirements including maintaining compliance information, establishing grievance procedures, designating a Civil Rights Coordinator, and providing notices of non-discrimination.

4. Title VI - LEP, Public Participation and Affirmative Compliance Obligation.

- a. As a recipient of EPA financial assistance, you are required by Title VI of the Civil Rights Act to provide meaningful access to LEP individuals. In implementing that requirement, the recipient agrees to use as a guide the Office of Civil Rights (OCR) document entitled "Guidance to Environmental Protection Agency Financial Assistance Recipients Regarding Title VI Prohibition Against National Origin Discrimination Affecting Limited English Proficient Persons." The guidance can be found at <http://frwebgate.access.gpo.gov/cgi-bin/getdoc.cgi?dbname=2004register&docid=fr25jn04-79.pdf>
- b. If the recipient is administering permitting programs under this agreement, the recipient agrees to use as a guide OCR's Title VI Public Involvement Guidance for EPA Assistance Recipients Administering Environmental Permitting Programs. The Guidance can be found at <http://edocket.access.gpo.gov/2006/pdf/06-2691.pdf>. In accepting this assistance agreement, the recipient acknowledges it has an affirmative obligation to implement effective Title VI compliance programs and ensure that its actions do not involve discriminatory treatment and do not have discriminatory effects even when facially neutral. The recipient must be prepared to demonstrate to EPA that such compliance programs exist and are being implemented or to otherwise demonstrate how it is meeting its Title VI obligations.

- E. Additional Term and Condition for Agricultural Landowners - Riparian Buffer Term for Agricultural Landowners. To be eligible for NEP implementation funding, provided directly or through a subaward, a private agricultural land owner whose property borders fresh or estuarine waters must establish and maintain a riparian buffer on all water courses on the property consistent with the National Marine Fisheries Service (NMFS) guidelines for Riparian Buffers Along Agricultural Water Courses in NW Washington and NRCS guidance on the NMFS guidelines. A land owner may be excluded from meeting this requirement if the funding is used solely for removal of shoreline armoring, onsite sewage system repair or replacement, engineered dike setbacks, or culvert or tide-gate replacements that provide for fish passage at all life stages. In some cases, the NMFS recommendations are framed in terms of ranges of buffer widths rather than point estimates, and expressed as probabilities of achieving desired outcomes. Local conditions and local circumstances matter, and may affect the choice of the riparian buffer most effective at achieving salmon recovery. Buffer widths may be less than specified in the table in cases where there is a scientific basis for doing so and all affected tribes in the watershed agree to deviations from the NMFS guidelines or where there are physical constraints on an individual parcel (e.g. transportation corridors, structures, naturally occurring).

SECTION 36. ORDER OF PRECEDENCE

This Agreement is entered into, pursuant to, and under the authority granted by applicable federal and state laws. The provisions of the Agreement shall be construed to conform to those laws. In the event of an inconsistency in the terms of this Agreement, or between its terms and any applicable statute, rule, or policy or procedure, the inconsistency shall be resolved by giving precedence in the following order:

- A. Federal law and binding executive orders;
- B. Code of federal regulations;
- C. Terms and conditions of a grant award to the state from the federal government;
- D. Federal grant program policies and procedures adopted by a federal agency;
- E. State law;
- F. Washington Administrative Code;
- G. Project Agreement;
- H. Board policies and procedures.

SECTION 37. AMENDMENTS

Amendments to this Agreement shall be binding only if in writing and signed by personnel authorized to bind each of the parties except period of performance extensions in and minor scope adjustments need only be signed by RCO's director or designee, unless the consent of the sponsor to an extension or scope adjustment is required by its auditing policies, regulations, or legal requirements, in which case, no extension shall be effective until so consented.

SECTION 38. LIMITATION OF AUTHORITY

Only RCO or RCO's delegate by writing (delegation to be made prior to action) shall have the express, implied, or apparent authority to alter, amend, modify, or waive any clause or condition of this Agreement. Furthermore, any alteration, amendment, modification, or waiver of any clause or condition of this Agreement is not effective or binding unless made in writing and signed by RCO.

SECTION 39. WAIVER OF DEFAULT

Waiver of any default shall not be deemed to be a waiver of any subsequent default. Waiver or breach of any provision of the Agreement shall not be deemed to be a waiver of any other or subsequent breach and shall not be construed to be a modification of the terms of the Agreement unless stated to be such in writing, signed by the director, or the director's designee, and attached to the original Agreement.

SECTION 40. APPLICATION REPRESENTATIONS -- MISREPRESENTATIONS OR INACCURACY OR BREACH

The funding board and RCO rely on the sponsor's application in making its determinations as to eligibility for, selection for, and scope of, funding grants. Any misrepresentation, error or inaccuracy in any part of the application may be deemed a breach of this Agreement.

SECTION 41. SPECIFIC PERFORMANCE

The funding board and RCO may enforce this Agreement by the remedy of specific performance, which usually will mean completion of the project as described in this Agreement. However, the remedy of specific performance shall not be the sole or exclusive remedy available to RCO. No remedy available to the funding board or RCO shall be deemed exclusive. The funding board or RCO may elect to exercise any, a combination of, or all of the remedies available to it under this Agreement, or under any provision of law, common law, or equity.

SECTION 42. TERMINATION

The funding board and RCO will require strict compliance by the sponsor with all the terms of this Agreement including, but not limited to, the requirements of the applicable statutes, rules and all funding board and RCO policies, and with the representations of the sponsor in its application for a grant as finally approved by the funding board. For federal awards, notification of termination will comply with 2 C.F.R. § 200.340.

A. For Cause. The funding board or the director may suspend or terminate the obligation to provide funding to the sponsor under this Agreement:

1. In the event of any breach by the sponsor of any of the sponsor's obligations under this Agreement; or
2. If the sponsor fails to make progress satisfactory to the funding board or director toward completion of the project by the completion date set out in this Agreement. Included in progress is adherence to milestones and other defined deadlines

In the event this Agreement is terminated by the funding board or director, under this section or any other section after any portion of the grant amount has been paid to the sponsor under this Agreement, the funding board or director may require that any amount paid be repaid to RCO for redeposit into the account from which the funds were derived.

B. Non Availability of Funds. The obligation of the RCO to make payments is contingent on the availability of state and federal funds through legislative appropriation and state allotment. If amounts sufficient to fund the grant made under this Agreement are not appropriated to RCO for expenditure for this Agreement in any biennial fiscal period, RCO shall not be obligated to pay any remaining unpaid portion of this grant unless and until the necessary action by the Legislature or the Office of Financial Management occurs. If RCO participation is suspended under this section for a continuous period of one year, RCO's obligation to provide any future funding under this Agreement shall terminate. Termination of the Agreement under this section is not subject to appeal by the sponsor.

C. For Convenience. Except as otherwise provided in this Agreement, RCO may, by ten (10) days written notice, beginning on the second day after the mailing, terminate this Agreement, in whole or in part. If this Agreement is so terminated, RCO shall be liable only for payment required under the terms of this Agreement for services rendered or goods delivered prior to the effective date of termination.

SECTION 43. DISPUTE HEARING

Except as may otherwise be provided in this Agreement, when a dispute arises between the sponsor and the funding board, which cannot be resolved, either party may request a dispute hearing according to the process set out in this section. Either party's request for a dispute hearing must be in writing and clearly state:

- A. The disputed issues;
- B. The relative positions of the parties;
- C. The sponsor's name, address, project title, and the assigned project number.

In order for this section to apply to the resolution of any specific dispute or disputes, the other party must agree in writing that the procedure under this section shall be used to resolve those specific issues. The dispute shall be heard by a panel of three persons consisting of one person chosen by the sponsor, one person chosen by the director, and a third person chosen by the two persons initially appointed. If a third person cannot be agreed on, the third person shall be chosen by the funding board's chair.

Any hearing under this section shall be informal, with the specific processes to be determined by the disputes panel according to the nature and complexity of the issues involved. The process may be solely based on written material if the parties so agree. The disputes panel shall be governed by the provisions of this Agreement in deciding the disputes.

The parties shall be bound by the decision of the disputes panel, unless the remedy directed by that panel shall be without the authority of either or both parties to perform, as necessary, or is otherwise unlawful.

Request for a disputes hearing under this section by either party shall be delivered or mailed to the other party. The request shall be delivered or mailed within thirty (30) days of the date the requesting party has received notice of the action or position of the other party which it wishes to dispute. The written Agreement to use the process under this section for resolution of those issues shall be delivered or mailed by the receiving party to the requesting party within thirty (30) days of receipt by the receiving party of the request.

All costs associated with the implementation of this process shall be shared equally by the parties.

SECTION 44. ATTORNEYS' FEES

In the event of litigation or other action brought to enforce contract terms, each party agrees to bear its own attorney fees and costs.

SECTION 45. GOVERNING LAW/VENUE

This Agreement shall be construed and interpreted in accordance with the laws of the State of Washington. In the event of a lawsuit involving this Agreement, venue shall be in Thurston County Superior Court if legally proper; otherwise venue shall be in a county where the project is situated. The sponsor, by execution of this Agreement acknowledges the jurisdiction of the courts of the State of Washington.

SECTION 46. PROVISIONS APPLICABLE ONLY IF FEDERALLY RECOGNIZED INDIAN TRIBE IS THE SPONSOR

In the cases where this Agreement is between the funding board (State) and a federally recognized Indian Tribe, the following governing law/venue applies, but only between those parties:

- A. Notwithstanding the above venue provision, if the State of Washington intends to initiate a lawsuit against a federally recognized Indian tribe relating to the performance, breach or enforcement of this Agreement, it shall so notify the Tribe. If the Tribe believes that a good faith basis exists for subject matter jurisdiction of such a lawsuit in federal court, the Tribe shall so notify the State within five days of receipt of such notice and state the basis for such jurisdiction. If the Tribe so notifies the State, the State shall bring such lawsuit in federal court; otherwise the State may sue the Tribe in the Thurston County Superior Court. Interpretation of the Agreement shall be according to applicable State law, except to the extent preempted by federal law. In the event suit is brought in federal court and the federal court determines that it lacks subject matter jurisdiction to resolve the dispute between the State and Tribal Party, then the parties agree to venue in Thurston County Superior Court.
- B. Any judicial award, determination, order, decree or other relief, whether in law or equity or otherwise, resulting from such a lawsuit shall be binding and enforceable on the parties. Any money judgment or award against a Tribe, tribal officers, employees, and members, or the State of Washington and its officers and employees may exceed the amount provided for in Section F: Project Funding of the Agreement in order to satisfy the judgment.
- C. The Tribe hereby waives its sovereign immunity for suit in federal and state court for the limited purpose of allowing the State to bring such actions as it determines necessary to give effect to this section and to the enforcement of any judgment relating to the performance, or breach of this Agreement. This waiver is not for the benefit of any third party and shall not be enforceable by any third party or by any assignee of the parties. In any enforcement action, the parties shall bear their own enforcement costs, including attorneys' fees.

For purposes of this provision, the State includes the RCO and any other state agencies that may be assigned or otherwise obtain the right of the RCO to enforce this Agreement.

SECTION 47. SEVERABILITY

The provisions of this Agreement are intended to be severable. If any term or provision is illegal or invalid for any reason whatsoever, such illegality or invalidity shall not affect the validity of the remainder of the Agreement.

Eligible Scope Activities

160

Project Sponsor: City of Marysville
Project Title: Qwuloolt Estuary Trail Development
Program: Aquatic Lands Enhancement Acct

Project Number: 14-1492
Project Type: Development
Approval: 7/1/2015

Project Metrics

Sites Improved

Project acres developed:	5.50
	<i>Includes total trail corridor converted to acres.</i>
Project acres renovated:	0.00

Development Metrics

Worksite #1, Ebey Slough Shoreline within the Qwuloolt Estuary

General Site Improvements

Develop viewpoint

Number of designated viewpoints:

2 new, 0 renovated

Viewpoints would be located at each end of trail overlooking levee breach.

Select the viewpoint structures:

Benches/seating, Viewing platform

Four (4) bench pads and seating fixtures will be developed for interpretive viewing. Platform will include signage and built in seating.

Install fencing/barriers

25,000 chain link

Install signs/kiosk

Number of kiosks:

0 new, 0 renovated

Number of interpretive signs/displays:

2 new, 0 renovated

Number of permanent entrance signs:

2 new, 0 renovated

Located at trail head at Ebey Waterfront Park and Harborview Park connections.

Project involves installation of informational signs (yes/no):

Yes

Install site furnishings

Shoreline protection

Linear feet of shoreline protection:

1100

1100

Select the shoreline protection type:

Rock armor

Rock Armory system of quarry spalls

Site Preparation

General site preparation

Surveying, SPCC Plan, Mobilization, Clearing and Grubbing

Eligible Scope Activities

161

Trails

Trail development

Linear miles of trail :

1.70 new, 0.00 renovated

Select the trail surface types:

New Trail construction

Asphalt, Compacted Gravel, Crushed rock, Hardened natural surface

Linear miles of boardwalk :

Asphalt @ 3" with 4" crushed rock base.

0.00 new, 0.00 renovated

Select the trail structures :

None

Number of trailheads:

2 new, 0 renovated

Upland Habitat And Sediment Project

Road drainage system improvements and reconstruction (C.6.c.1)

Miles of Road Treated for drainage improvements and reconstruction (C.6.c.2):

1.70

Cultural Resources

Cultural resources

This figure anticipates limited need as the project has little or no excavation elements.

Permits

Obtain permits

City to manage shoreline and grading permits

Architectural & Engineering

Architectural & Engineering (A&E)

Includes Landscape Architecture and City Engineering

Milestone Report By Project

Project Number: 14-1492 D
Project Name: Qwuloolt Estuary Trail Development
Sponsor: Marysville City of
Project Manager: Kyle Guzlas

X	!	Milestone	Target Date	Comments/Description
X		Preliminary Design to RCO	04/15/2015	
X		Design Initiated	07/01/2015	
X	!	Cultural Resources Complete	07/01/2015	RCO has completed cultural resources consultation with Native American tribes and the Department of Archaeology and Historic Preservation. No further cultural resource investigation is required at this time. DAHP Log No: 072015-14-RCFB
		Project Start	09/15/2015	
	!	Progress Report Submitted	12/31/2015	
		60% Plans to RCO	12/31/2015	
		Applied for Permits	01/31/2016	
		All Bid Docs/Plans to RCO	04/30/2016	
		Bid Awarded/Contractor Hired	05/31/2016	
	!	Construction Started	06/15/2016	
	!	Progress Report Submitted	06/30/2016	
		RCO Interim Inspection	07/20/2016	
	!	Annual Project Billing	07/31/2016	
		90% Construction Complete	08/31/2016	
		Funding Acknowl Sign Posted	08/31/2016	
		RCO Final Inspection	09/15/2016	
		Construction Complete	12/31/2016	
		Final Billing to RCO	02/28/2017	
		Final Report in PRISM	02/28/2017	
	!	Agreement End Date	03/31/2017	

X = Milestone Complete

! = Critical Milestone

Index #11

CITY OF MARYSVILLE

EXECUTIVE SUMMARY FOR ACTION

CITY COUNCIL MEETING DATE: October 12, 2015

AGENDA ITEM: Relinquishment and Termination of Easement – Lighthouse Storage	AGENDA SECTION:	
PREPARED BY: Deryl Taylor, Development Services Technician	AGENDA NUMBER:	
ATTACHMENTS: <ul style="list-style-type: none"> • Resolution • Relinquishment of Esmt AFN 9809170371 • Exhibit A – Property Description • Exhibit B - Utility Easement • Map – Peak Engineering #99194 	APPROVED BY:	
	MAYOR	CAO
BUDGET CODE:	AMOUNT:	

This 'Relinquishment and Termination of Easement' is for the benefit of Lighthouse Storage, located at 8119 State Avenue. The water main was constructed in a different location and the new easement was recorded under AFN 200009210545.

RECOMMENDED ACTION: Public Works and Community Development staff recommends Council authorize the Mayor to sign the Resolution and the Relinquishment and Termination of Easement.
COUNCIL ACTION:

CITY OF MARYSVILLE
Marysville, Washington

RESOLUTION NO. _____

**A RESOLUTION OF THE CITY OF MARYSVILLE, WASHINGTON,
AUTHORIZING TERMINATION AND RELINQUISHMENT OF A CITY-
OWNED EASEMENT ON PRIVATE PROPERTY**

WHEREAS, in 1998, Lighthouse Self Storage – Marysville, an Oregon LLC, granted a 10 foot utility easement to the City of Marysville, recorded under Auditor’s File Number 9809170371; and

WHEREAS, utilities were constructed in a different location than the easement described in **Exhibit B**, and the City has no current, past, or future use for the utility easement; and

WHEREAS, the owner of a property encumbered by the utility line easement has requested that the City relinquish said easement;

WHEREAS, the City Council of the City of Marysville has determined that the utility easement is surplus to the City’s needs;

NOW, THEREFORE, BE IT RESOLVED BY THE CITY COUNCIL OF THE CITY OF MARYSVILLE AS FOLLOWS:

That the Mayor of the City of Marysville is hereby authorized to execute such instruments as may be required to relinquish, terminate and extinguish the City’s interest in the 10 foot utility line easement described in **EXHIBIT B**.

PASSED by the City Council and APPROVED by the Mayor this _____ day of _____, 2015.

CITY OF MARYSVILLE

By: _____
JON NEHRING, MAYOR

Attest:

By: _____
CITY CLERK

Approved as to form:

By: _____
JON WALKER, CITY ATTORNEY

After recording return to:

CITY OF MARYSVILLE
 1049 STATE AVENUE
 MARYSVILLE, WA 98270

**RELINQUISHMENT AND TERMINATION OF EASEMENT
 AS TO SPECIFIC PROPERTY**

Grantor: CITY OF MARYSVILLE
 Grantee: LIGHTHOUSE SELF STORAGE
 Legal Description: Exhibit A – Ptn of NE ¼ of SW ¼ Sec 21, T30N, R5E, WM
 Assessor's Tax Parcel ID#: 30052100317500 & 30052100317000
 Reference No.:

WHEREAS, in 2000, City of Marysville SPL AFN 200008215001 was approved with a dedication to the City of Marysville of a water line easement Rec. No. 9809170371; and

WHEREAS, the water line was constructed in a different location than the above described easement, and the City has no current, past, or future use for the water line easement; and

WHEREAS, the City Council of the City of Marysville has determined the water line easement to be surplus to the City's needs;

NOW, THEREFORE,

FOR AND IN CONSIDERATION OF the above representations, the CITY OF MARYSVILLE, a municipal corporation of the State of Washington, hereby relinquishes, terminates and extinguishes the water line easement Rec. No. 9809170371.

DATED this _____ day of _____, 2015

CITY OF MARYSVILLE

BY _____

_____, Mayor

STATE OF WASHINGTON)
)ss.
COUNTY OF SNOHOMISH)

I certify that I know or have satisfactory evidence that _____ is the person who appeared before me, and said person acknowledged that he signed this instrument, on oath stated that he was authorized to execute the instrument and acknowledged it as the Mayor of the CITY OF MARYSVILLE to be the free and voluntary act of such party for the uses and purposes mentioned in the instrument.

DATED this _____ day of _____, 2015.

(Legibly print name of notary)
NOTARY PUBLIC in and for the State of
Washington, residing at _____
My commission expires _____

(Note: Do not write or stamp in 1" margins)

**CORE DESIGN, INC.
BELLEVUE WA 98007**

Core Project No: 15091
9/28/15

LEGAL DESCRIPTION

**EXHIBIT A
LIGHTHOUSE SELF STORAGE PROPERTY**

PARCEL A

LOT 7 OF CITY OF MARYSVILLE SHORT PLAT, ACCORDING TO SHORT PLAT RECORDED AUGUST 21, 2000 UNDER RECORDING NO. 200008215001 OF OFFICIAL RECORDS, IN SNOHOMISH COUNTY, WASHINGTON.

PARCEL B

THE NORTH 100 FEET OF THE FOLLOWING DESCRIBED PROPERTY:

BEGINNING AT THE NORTHEAST CORNER OF THE SOUTHEAST QUARTER OF THE NORTHEAST QUARTER OF THE SOUTHWEST QUARTER OF SECTION 21, TOWNSHIP 30 NORTH, RANGE 5 EAST OF THE WILLAMETTE MERIDIAN, IN SNOHOMISH COUNTY, WASHINGTON;
THENCE NORTH 294 FEET;
THENCE SOUTH 89°50'41" WEST 618.69 FEET TO TRUE POINT OF BEGINNING;
THENCE CONTINUE WEST ON SAME BEARING 250 FEET, MORE OR LESS, TO EASTERLY MARGIN OF OLD PACIFIC HIGHWAY AS DEEDED TO SNOHOMISH COUNTY BE DEED RECORDED IN VOLUME 33 OF DEEDS AT PAGE(S) 119;
THENCE SOUTHERLY ALONG THE EASTERLY MARGIN OF OLD PACIFIC HIGHWAY FOR 234 FEET, MORE OR LESS, TO A POINT 60 FEET NORTH OF THE NORTH LINE OF SAID SOUTHEAST QUARTER OF THE NORTHEAST QUARTER;
THENCE NORTH 89°50'41" EAST FOR 250 FEET;
THENCE NORTH TO THE TRUE POINT OF BEGINNING.

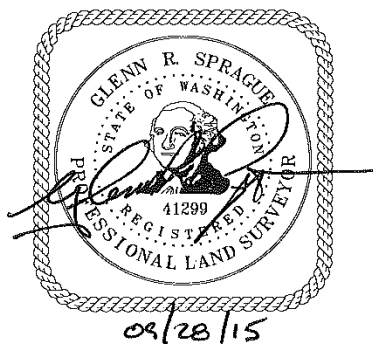

**CORE DESIGN, INC.
BELLEVUE WA 98007**

Core Project No: 15091
9/28/15

LEGAL DESCRIPTION

**EXHIBIT B
WATERLINE EASEMENT – REC. NO. 9809170371**

AN EASEMENT FOR WATER LINE PURPOSES BEING 5.00 FEET ON BOTH SIDES OF THE AS-CONSTRUCTED WATERLINE, MORE PARTICULARLY DESCRIBED AS FOLLOWS;

COMMENCING AT THE SOUTHEAST CORNER OF THE NORTH HALF OF THE NORTHEAST QUARTER OF THE SOUTHWEST QUARTER SECTION 21, TOWNSHIP 30 NORTH, RANGE 5 EAST, W.M.; THENCE SOUTH 89°50'41" WEST A DISTANCE OF 900.49 FEET TO THE EASTERLY MARGIN OF STATE STREET; THENCE NORTH 04°44'13" EAST ALONG SAID EASTERLY MARGIN A DISTANCE OF 55.20 FEET TO THE TRUE POINT OF BEGINNING; THENCE NORTH 89°50'41" EAST A DISTANCE OF 2.45 FEET TO POINT "A"; THENCE CONTINUING NORTH 89°50'41" EAST A DISTANCE OF 255.55 FEET; THENCE NORTH 04°57'11" EAST A DISTANCE OF 8.04 FEET TO POINT "B"; THENCE NORTH 89°50'41" EAST A DISTANCE OF 407.63 FEET TO POINT "C"; THENCE CONTINUING NORTH 89°50'41" EAST A DISTANCE OF 9.19 FEET TO POINT "D"; THENCE CONTINUING NORTH 89°50'41" EAST A DISTANCE OF 18.70 FEET; THENCE SOUTH 00°09'19" EAST A DISTANCE OF 40.00 FEET; THENCE SOUTH 85°29'24" EAST A DISTANCE OF 221.13 FEET; THENCE SOUTH 46°22'38" EAST A DISTANCE OF 64.10 FEET; THENCE SOUTH 01°22'38" EAST A DISTANCE OF 125.37 FEET TO A POINT ON THE SOUTH LINE OF LOT 4 OF BUTLERS FIVE LOT PLAT RECORDED IN VOLUME 23 OF PLATS AT PAGE 101 RECORDS OF SNOHOMISH COUNTY, FROM WHICH THE SOUTHWEST CORNER OF SAID LOT 4 BEARS SOUTH 89°50'41" WEST A DISTANCE OF 63.97 FEET AND THE TERMINUS OF THIS DESCRIPTION

ALSO BEGINNING AT AFOREMENTIONED POINT "A"; THENCE SOUTH 00°08'88" EAST 36.81 FEET TO THE TERMINUS OF THIS DESCRIPTION.

ALSO BEGINNING AT AFOREMENTIONED POINT "B", THENCE NORTH
04°57'11" EAST A DISTANCE OF 166.45 FEET TO THE TERMINUS OF THIS
DESCRIPTION.

ALSO BEGINNING AT THE AFOREMENTIONED POINT "C"; THENCE NORTH
00°09'19" WEST A DISTANCE OF 161.78 FEET; THENCE DUE EAST A
DISTANCE OF 19.50 FEET TO THE TERMINUS OF THIS DESCRIPTION

ALSO BEGINNING AT AFOREMENTIONED POINT "D"; THENCE SOUTH
00°09'19" EAST A DISTANCE OF 13.00 FEET TO THE TERMINUS OF THIS
DESCRIPTION.

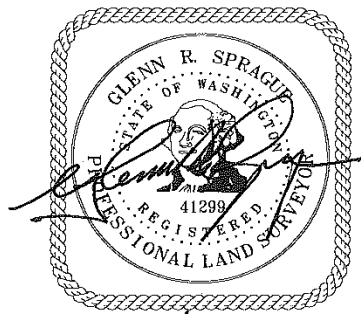

09/28/15

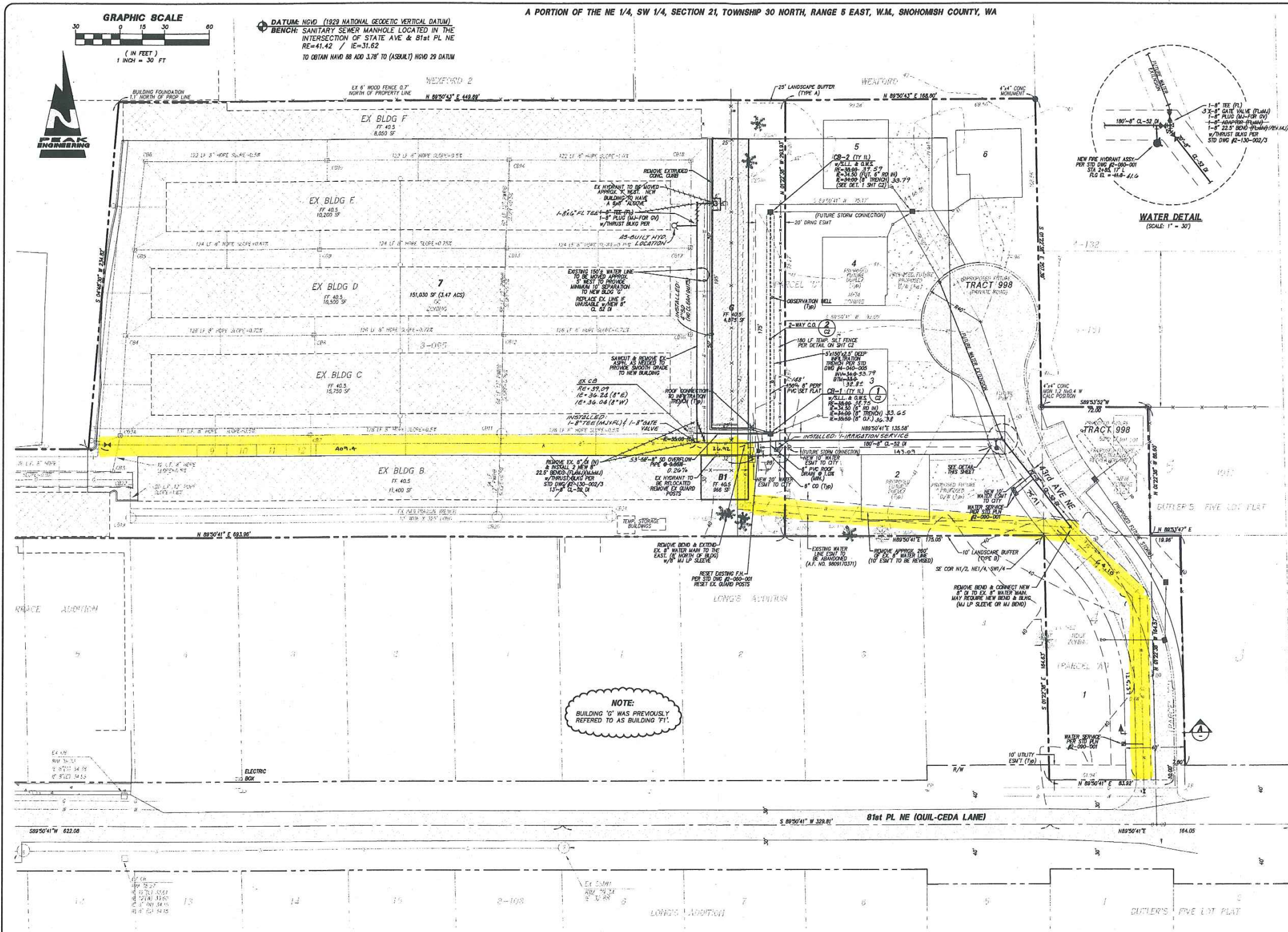

NOTE:
BUILDING 'G' WAS PREVIOUSLY REFERRED TO AS BUILDING 'F'

PEAK ENGINEERING INC.
1720 GROVE STREET, MARYSVILLE, WASHINGTON 98270
(360) 656-6986 / FAX: (360) 656-7828

CITY OF MARYSVILLE
APPROVED FOR CONSTRUCTION
DATE: 10/11/99

AS-BUILT SURVEY & TOPOGRAPHIC INFORMATION PROVIDED BY:
JEFF CURTIS AND ASSOCIATES
P.O. BOX 1512
LAKE STEVENS, WA 98258
(425) 397-8424

APPLICANT
DAVID A. LEE
LIGHTHOUSE SELF STORAGE, LLC
13333 BELLEVUE-REIMOND RD
SUITE 223
BELLEVUE, WA 98005
PH: 425-957-1411

GRADING QUANTITIES
CUT: 50 CY's
FILL: 50 CY's

AS-BUILT DECLARATION
WE HEREBY DECLARE THAT THE ROAD AND STORM DRAINAGE IMPROVEMENTS ARE LOCATED AS SHOWN ON THESE RECORD DRAWINGS.
BY: PROJECT ENGINEER DATE: _____
BY: PLAT DEVELOPER / OWNER DATE: _____
CALL 48 HOURS BEFORE YOU DIG 1-800-424-8888

LIGHTHOUSE SELF STORAGE "AS-BUILT"
COMMERCIAL TESC, GRADING, DRAINAGE AND UTILITY PLAN

PROJECT NO. 99194
DWG C1
OF 2

APPROVED FOR CONSTRUCTION CITY OF MARYSVILLE				
BY:	<i>Errol J. Jensen</i> ERROL JENSEN, FIRE MARSHAL			
DATE:	10-12-99 THIS APPROVAL VALID FOR 18 MONTHS			
APPROVED FOR CONSTRUCTION CITY OF MARYSVILLE				
BY:	<i>Alora Hirashima</i> ALORA HIRASHIMA, CITY PLANNER			
DATE:	10-20-99 THIS APPROVAL VALID FOR 18 MONTHS			
APPROVED FOR CONSTRUCTION CITY OF MARYSVILLE				
BY:	<i>Owen Carter, P.E.</i> OWEN CARTER, P.E., CITY ENGINEER			
DATE:	10/20/99 THIS APPROVAL VALID FOR 18 MONTHS			
REV. No.	REVISION	DATE OF REVISION	CITY APPROVAL	DATE OF CITY APPROVAL
-	ISSUED	7/21/99		
1	REV PER CITY	9/15/99		
2	REV PER CITY	10/10/99		
3	AS-BUILT	1/4/00		

Update
Index #12

**CITY OF MARYSVILLE AGENDA BILL
EXECUTIVE SUMMARY FOR ACTION**

CITY COUNCIL MEETING DATE: 10/12/2015

AGENDA ITEM: Correction of Easement	
PREPARED BY: Kyle Woods, Engineering Technician	DIRECTOR APPROVAL:
DEPARTMENT: Engineering	
ATTACHMENTS: Septic As-built; Correction of Easement Document	
BUDGET CODE: N/A	AMOUNT: N/A
SUMMARY:	

A correction of easement is necessary and required by the Snohomish Health District to construct and maintain a septic system at 6302 152nd ST NE, Marysville (more commonly known as the Strawberry Fields Caretaker’s residence). The septic system is owned and maintained by the City of Marysville, has been constructed, and is currently in use. The Snohomish Health District will not issue a final permit for said septic system until a drain field easement is recorded.

RECOMMENDED ACTION: Staff recommends that the Council authorize the Mayor to sign the correction of easement for purposes of utilizing a City owned septic system.
--

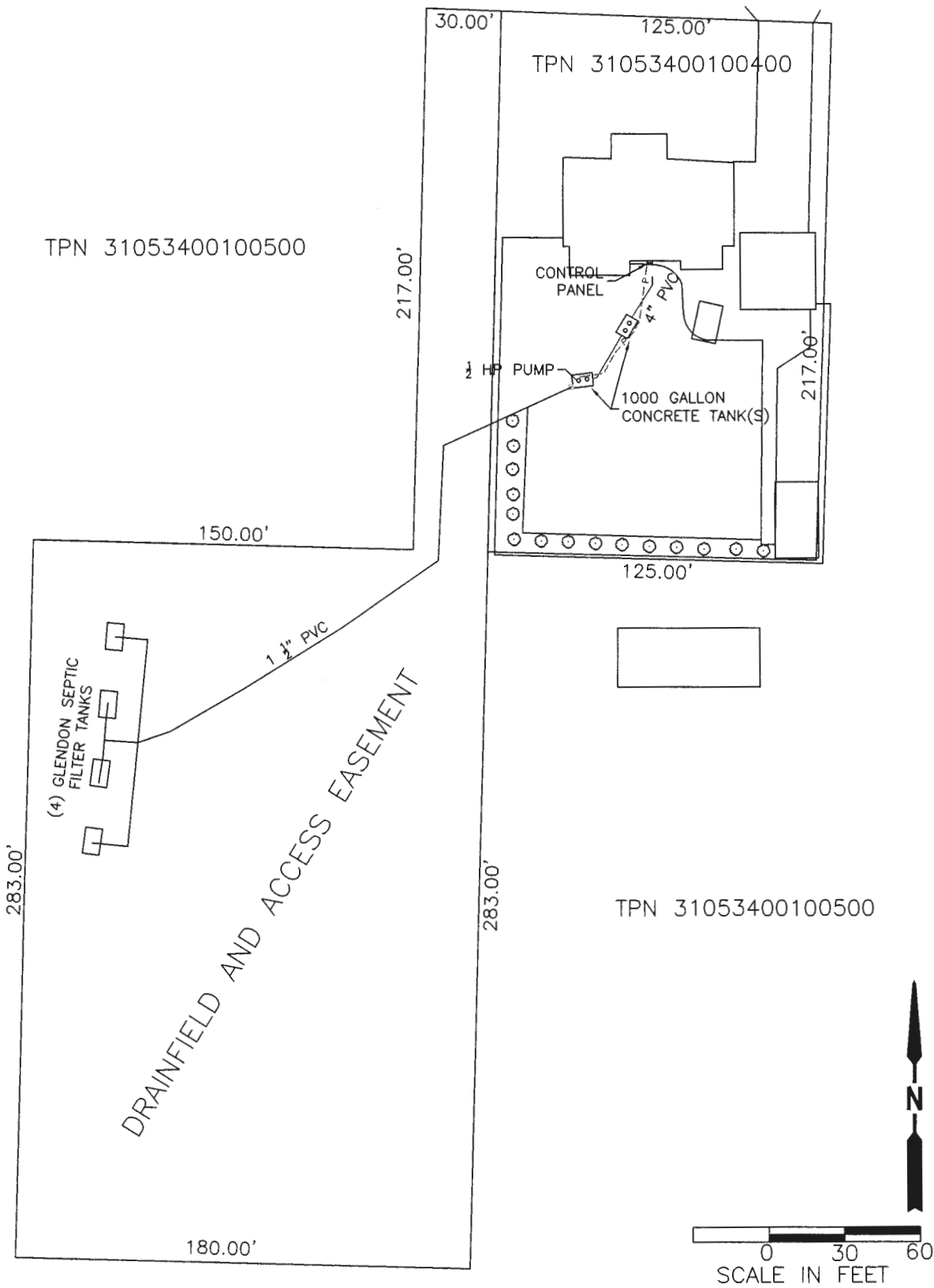

6302 152ND ST NE
 MARYSVILLE, WA 98271

CITY OF MARYSVILLE
 PUBLIC WORKS DEPARTMENT
 80 COLUMBIA AVE MARYSVILLE, WA 98270 (360) 363-8100

SEPTIC AS-BUILT
 TPN 31053400100400

9/15/2015
 DATE
 1 of 1
 NUMBER

AFTER RECORDING, RETURN TO:

CITY OF MARYSVILLE
80 COLUMBIA AVENUE
MARYSVILLE, WA 98270
360-363-8286

DOCUMENT: CORRECTION OF EASEMENT

REFERENCES: CORRECTION OF EASEMENT AFN: 201312060272

GRANTOR: CITY OF MARYSVILLE
80 COLUMBIA AVENUE
MARYSVILLE, WA 98270
360-363-8286

GRANTEE: CITY OF MARYSVILLE
80 COLUMBIA AVENUE
MARYSVILLE, WA 98270
360-363-8286

ABBREVIATED LEGAL DESCRIPTION FOR AUDITOR'S INDEXING ONLY:

A PORTION OF THE SE ¼ OF THE NE ¼
AND
A PORTION OF THE SW ¼ OF THE NE ¼
OF
SECTION 34, TOWNSHIP 31 NORTH, RANGE 5 EAST, WM

ASSESSOR'S PROPERTY TAX ACCOUNT NUMBERS:

GRANTOR: 31053400100500

GRANTEE: 31053400100400

DECLARATION OF EASEMENT

KNOW ALL MEN by these presents that the City of Marysville is the owner of the following described PARCEL A and PARCEL B:

FOR PARCEL A, SEE EXHIBIT A

FOR PARCEL B, SEE EXHIBIT B

WHEREAS the City of Marysville does hereby grant, convey, establish and create an easement for the placement, maintenance, construction, reconstruction, repair and upkeep of a drainfield for septic tank and sewer line leading thereto, including the cutting and removal of brush, trees and other obstructions which interfere with the use of said easement, together with the rights of ingress, egress and regress, over, under, along and across that portion of PARCEL A, described as follows:

FOR EASEMENT DESCRIPTION, SEE EXHIBIT C

Said easement is appurtenant to and for the benefit of the City of Marysville, their heirs, future owners, successors and assigns of PARCEL B.

Said easement shall be canceled at such time as the Snohomish Health District will approve cancellation of same.

IN WITNESS THEREOF, the undersigned have hereunto set their hand and seal this _____ day of _____, 20 ____.

GRANTOR/GRANTEE

_____.

City of Marysville

STATE OF WASHINGTON)

)

COUNTY OF SNOHOMISH)

I CERTIFY THAT I KNOW OR HAVE SATISFACTORY EVIDENCE THAT _____ IS THE PERSON WHO APPEARED BEFORE ME, AND SAID PERSON ACKNOWLEDGED THAT HE/SHE SIGNED THIS INSTRUMENT, AN OATH STATED THAT HE/SHE WAS AUTHORIZED TO EXECUTE THE INSTRUMENT AND ACKNOWLEDGED IT AS THE _____ OF THE CITY OF MARYSVILLE, TO BE THE FREE AND VOLUNTARY ACT OF SUCH PARTY FOR THE USES AND PURPOSES MENTIONED IN THE INSTRUMENT.

DATED THIS _____ DAY OF _____, 20 _____.

SIGNATURE: _____

(PRINT NAME) _____

NOTARY PUBLIC IN AND FOR THE STATE OF WASHINGTON,

RESIDING AT _____

MY APPOINTMENT EXPIRES _____

EXHIBIT A**PARCEL A**

TPN: 31053400100500

LEGAL DESCRIPTION

Portions of the Northeast Quarter of Section 34 and the Southeast Quarter of Section 34, all in Township 31 North, Range 5 East, W.M., Snohomish County, Washington, described as follows:

Beginning 15 feet South of the southeast corner of the Northeast Quarter of the Northeast Quarter of Section 34, Township 31 North, Range 5 East, W.M.; thence West 1221 feet to the point of beginning; thence continue West to the west line of the Northeast Quarter of said Section; thence South to the southwest corner of the Northwest Quarter of the Southeast Quarter; thence East to a point 1521 feet West of the east line of said Section; thence North 1409 feet, more or less, to a point 1236 feet South of the north line of the Southwest Quarter of the Northeast Quarter; thence East 300 feet; thence North 1221 feet to the point of beginning;

EXCEPT County Road;

ALSO EXCEPT the following described tract:

Beginning 15 feet South of the southeast corner of the Northeast Quarter of the Northeast Quarter of Section 34, Township 31 North, Range 5 East, W.M.; thence West 1221 feet to the point of beginning; thence continue West 125 feet; thence South 217 feet; thence East 125 feet; thence North 217 feet to said point of beginning.

SUBJECT TO those items disclosed in that Warranty Deed recorded under Snohomish County Auditor's File Number 9607260796.

EXHIBIT B**PARCEL B**

TPN: 31053400100400

LEGAL DESCRIPTION

Portion of Section 34, Township 31 North, Range 5 East, W.M., described as follows:

Beginning 15 feet South of the southeast corner of the Northeast Quarter of the Northeast Quarter of Section 34, Township 31 North, Range 5 East, W.M.; thence West 1221 feet to the point of beginning; thence continue West 125 feet; thence South 217 feet; thence East 125 feet; thence North 217 feet to said point of beginning.

SUBJECT TO those items disclosed in that Warranty Deed recorded under Snohomish County Auditor's File Number 9702280253.

EXHIBIT C
EASEMENT
LEGAL DESCRIPTION

That portion of PARCEL A, described in EXHIBIT A, described as follows:

Beginning at the southwest corner of said PARCEL B, EXHIBIT B, thence North 1 degree 40 minutes 57 seconds West, along the west line of said PARCEL B, a distance of 217.00 feet to the northwest corner of said PARCEL B; thence South 89 degrees 56 minutes 34 seconds West, along the north line of said PARCEL A, EXHIBIT A, a distance of 30.00 feet; thence South 1 degree 40 minutes 57 seconds East, parallel with the west line of said PARCEL B, a distance of 217.00 feet; thence South 89 degrees 56 minutes 34 seconds West, parallel with the north line of said PARCEL A, a distance of 150.00 feet; thence South 1 degrees 40 minutes 57 seconds East a distance of 283.00 feet; thence North 89 degrees 56 minutes 34 seconds East a distance of 180.00 feet to a line that bears South 1 degree 40 minutes 57 seconds East from the southwest corner of said PARCEL B; thence North 1 degree 40 minutes 57 seconds West a distance of 283.00 feet to said southwest corner and the point of beginning.

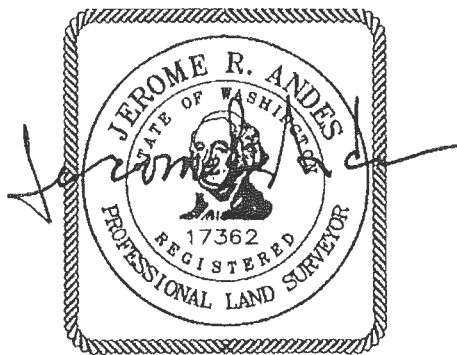

9/17/2015

Update
Index #15

CITY OF MARYSVILLE

EXECUTIVE SUMMARY FOR ACTION

CITY COUNCIL MEETING DATE: October 12, 2015

AGENDA ITEM: Appointments to the Salary Commission	AGENDA SECTION: Mayor's Business	
PREPARED BY: April O'Brien, Deputy City Clerk	AGENDA NUMBER:	
ATTACHMENTS: Appointment Forms	APPROVED BY:	
	MAYOR	CAO
BUDGET CODE:	AMOUNT:	

Summary:

The Marysville Salary Commission currently has two vacancies. One vacancy was created by the resignation of Larry Nyland due to work commitments. Mayor Nehring is recommending the appointment of Tom King to fill this position, serving until June 23, 2016.

Mayor Nehring is recommending the appointment of Amanda Garlock to fill the second vacant position, serving until July 14, 2018.

RECOMMENDED ACTION: Mayor Nehring recommends the City Council confirm the Salary Commission appointments of Tom King, serving until June 23, 2016 and Amanda Garlock, serving until July 14, 2018.
COUNCIL ACTION:

Office of the Mayor
Jon Nehring
1049 State Avenue
Marysville, WA 98270
Phone: 360-363-8000
Fax: 360-651-5033
marysvillewa.gov

APPOINTMENT

I, Jon Nehring, duly elected and acting Mayor of the City of Marysville, do hereby appoint Tom King as a member of the SALARY COMMISSION of the City of Marysville, pursuant to the provisions of the Marysville Municipal Code 2.51; dated this 12 day of October, 2015.

M A Y O R

I do swear and affirm I will perform the duties assigned to me as a member of the SALARY COMMISSION of the City of Marysville in the manner required by law.

Dated this 12 day of October, 2015

TOM KING

This term of appointment expires the 23 day of June, 2016.

Office of the Mayor
Jon Nehring
1049 State Avenue
Marysville, WA 98270
Phone: 360-363-8000
Fax: 360-651-5033
marysvillewa.gov

APPOINTMENT

I, Jon Nehring, duly elected and acting Mayor of the City of Marysville, do hereby appoint Amanda Garlock as a member of the SALARY COMMISSION of the City of Marysville, pursuant to the provisions of the Marysville Municipal Code 2.51; dated this 12 day of October, 2015.

M A Y O R

I do swear and affirm I will perform the duties assigned to me as a member of the SALARY COMMISSION of the City of Marysville in the manner required by law.

Dated this 12 day of October, 2015

AMANDA GARLOCK

This term of appointment expires the 14 day of July, 2018.