



Hanson Sisters, LLC
17406 19th Ave NE, Marysville, WA 98271
PN PA 23-012
1st Submittal: May 2023
2nd Submittal: November 2023

**Stormwater Site Plan
Report
for
English Crossing**

Prepared by:

Mier Zhou, P.E.

360-652-9727

Email: Mier@landtechway.com



Reviewed by:

Tyler Foster, P.E.

360-652-9727

Email: Tyler@landtechway.com

11/17/2023

Preliminary

Contents

Contents	i
Section 1 – Report Summary	1-1
1.1 Project Description	1-1
1.2 Project Data Summary.....	1-3
Section 2 - Minimum Requirements.....	1
2.1 Assessment of Minimum Requirements and Thresholds	1
2.2 MR #1: Preparation of Stormwater Site Plans	2
2.3 MR #2: Stormwater Pollution Prevention Plans (SWPPPs).....	5
2.4 MR #3: Source Control of Pollution.....	6
2.5 MR #4: Preservation of Natural Drainage Systems and Outfalls	7
2.6 MR #5: On-Site Stormwater Management	8
2.7 MR #6: Runoff Treatment	10
2.8 MR #7: Flow Control.....	11
2.9 MR #8: Wetlands Protection	12
2.10 MR # 9: Operation and Maintenance.....	13
Section 3 - Maps & Figures	3-1
Section 4 Support Data	4-7
4.1 Soils Data	4-7
Section 5 Works Cited.....	5-9
5.1 Topographic Data	5-9
Section 6 - Continuous Simulation Modeling	6-1
6.1 Continuous Simulation Background.....	6-1
6.2 Modeling Methodology.....	6-1
Section 7 - Software Output	7-1
7.1 Biocells A & B.....	7-1
7.2 Biocell C	7-14
7.3 Biocell D.....	7-23
7.4 Biocell E	7-32

Figures

Figure 1 - Vicinity Map	3-1
Figure 2 - Existing Conditions (not to scale)	3-2
Figure 3 – Downstream Flow Path	3-3
Figure 4 - Site Plan	3-4
Figure 5 – Soil Map (Not to Scale).....	3-5
Figure 6 – Basin Map.....	3-6

Tables

Table 1 - Project Parcel Summary	1-3
Table 2 - Project Area Analysis & Activities Summary	1-3

Acronyms

The following acronyms and abbreviations may or may not be called out within the body of this report.

○ ASTM	- American Society for Testing and Materials
○ BMPs	- Best Management Practices
○ CB	- Catch Basin
○ CAO	- Critical Areas Ordinance
○ CESCL	- Certified Erosion and Sediment Control Lead
○ DOE	- Department of Ecology
○ EDDS	- Engineering Design & Development Standards
○ FEMA	- Federal Emergency Management Agency
○ HSPF	- Hydrological Simulation Program—Fortran
○ LiDAR	- Light Detecting And Ranging
○ LDA	- Land disturbing activity
○ LID	- Low Impact Development
○ LID Manual	- DOE 2005 LID Technical Guidance Manual for Puget Sound
○ MRs	- Minimum Requirements (for Stormwater Management)
○ MS4	- Municipal Separate Storm Sewer System
○ MSL	- Mean Sea Level
○ NAVD88	- North American Vertical Datum of 1888
○ NGVD29	- National Geodetic Vertical Datum of 1929
○ NPDES	- National Pollutant Discharge Elimination System
○ NRCS	- Natural Resources Conservation Service
○ NPGIS	- Non-Pollutant Generating Impervious Surface
○ O&M	- Operations and Maintenance
○ PGIS	- Pollutant Generating Impervious Surface
○ PGPS	- Pollutant Generating Pervious Surface
○ PLSS	- Public Land Survey System
○ POC	- Point of Compliance
○ RCW	- Revised Code of Washington
○ ROW	- Right-of-Way
○ SCDM-2010	- Snohomish County 2010 Drainage Manual
○ SMMWW	- DOE 2005 Stormwater Management Manual for Western Washington
○ SWPPP	- Stormwater Pollution Prevention Plan
○ TDA	- Threshold Discharge Area
○ TESC	- Temporary Erosion and Sediment Controls
○ USDA	- United States Department of Agriculture
○ US EPA	- United States Environmental Protection Agency
○ WSDOT	- Washington State Department of Transportation
○ WWHM	- Western Washington Hydrology Model

Section 1 – Report Summary

1.1 Project Description

Hanson Sister, LLC is proposing the development of 19.52-*acres* of land in Northwest Marysville, WA off of 19th Ave NE. The parcel is currently vacant and vegetated with pasture.

The development of the parcel will result in Condominium Townhomes with 243-Units and drive aisles. Each unit is allocated to accept a maximum of 85% total impervious of roof and driveway with the remaining portion consisting of lawn. Open space areas for both passive and active recreation will be located outside of the proposed lots.

The proposed road access for the development entrance will be from 19th Ave NE at two locations. The development consists of units, driveways, drive aisles, on-site recreation and stormwater facilities.

Per NRCS mappings, type “C/D” Custer fine sandy loam soils are found through the bulk of the site into the east. A band of Norma Taxadjunct loam soils are located in the south portion of the site. An intrusion from the north of Kitsap silt loam also exists. The site is mapped as the Marysville Sand Member-Recession Outwash.

The 2019 DOE Stormwater Management Manual for Western Washington will be used for stormwater management guidance. Stormwater management BMPs and engineered designs are specified in this report.

Stormwater facilities will consist of bioretention facilities.

The entire developable project area is in one natural discharge area with a discharge location. Stormwater BMPs will be employed to mitigate polluted and unpolluted surface water flows.

Summary Stormwater Management

The project qualifies as 'new development' because there are less than 35% of existing impervious areas. The proposed condition of the fully developed site will have more than 5,000sf impervious areas. Per Figure 2.4.1 Vol. 1 of the 2019 SMMWW, all minimum requirements shall apply for this project.

This project triggers MRs 1-9 and is within the City's UGA. The project will choose to adhere to List #2 of MR #5. On-site stormwater BMPs will consist only of BMPT5.13. Feasibility analysis for individual lot BMPs is provided in MR #5 of the report. However, the overall site stormwater management will mirror the requirements and intent of MR #5.

Flow control requirements for the site will be met by detention. The majority of runoff from impervious surfaces and converted surfaces will be detained. A small portion of the site bypasses facilities for detention. The site as a whole meets the flow control threshold requirement matching the fully-forested condition.

Water quality will be met by percolating stormwater through bioretention treatment soils. The bioretention cell mitigates polluted stormwater through physical, chemical, and biological treatment processes.

1.2 Project Data Summary

Existing and proposed project areas are presented for determination of stormwater management requirements based on prescribed thresholds as outlined in the Marysville Municipal Code (MMC 22C) and the 2019 SMMWW Vol-1, Ch-2, Section 2.4 are summarized in the following tables.

Table 1 - Project Parcel Summary

Project Data:	
Applicant	Hanson Sister, LLC
Site Owner	Hanson Sisters, LLC
Project Name	English Crossing
Project T.S.R. Location	TwN 31 N, Rng 5 E, Sec 19, Qtr-SE
Project Address	17406 19th Ave NE, Marysville, WA 98271
Parcel ID(s)	310519-004-012-00
Watershed	Snohomish
Basin	Snohomish
Sub-Basin	Quilceda Creek
WRIA Number	7-Snohomish
Analysis Standard	2019 DOE SMMWW

Table 2 - Project Area Analysis & Activities Summary

Existing Conditions:		
Total Site Area	850,175	sf (19.52 ac)
Existing Impervious Area	0	sf (0.00 ac) 0.0%
Proposed Activity:		
Proposed Activity	Condominium Townhomes	
Total Proposed Disturbance Area	838,082	sf (19.24 ac)
Proposed Grading Area	838,082	sf (19.24 ac)
Proposed New NPGIS Onsite (Roof)	201,861	sf (4.63 ac)
Proposed New PGIS Onsite (Road, Sidewalk & Driveway)	193,688	sf (4.45 ac)
Proposed Replaced Impervious Area	0	sf (0.00 ac)
Native Vegetation convert to Lawn	0	sf (0.00 ac)
Native Vegetation convert to Pasture	0	sf (0.00 ac)
Total New Impervious Area Onsite	395,549	sf (9.08 ac)
Grading is ≤ 2 feet from P/L	No	
Any excavation 4+' at <1:1 slope to P/L	No	
Fill Slopes 4+' and >33% slope	No	

Section 2 - Minimum Requirements

2.1 Assessment of Minimum Requirements and Thresholds

Minimum requirements and thresholds are established by City of Marysville Municipal Code 14.15.050 – Minimum Requirements. Minimum Requirements for new development and Redevelopment are based on a development’s disturbance area. Existing and proposed project areas for determination of stormwater management requirements are presented in Table 2.

The existing impervious area is less than 35% so this project qualifies as ‘new development’. The proposed condition of the fully developed site will have impervious area in excess of 5,000 sf. This requires construction activities and stormwater management to comply with Minimum Requirements 1 through 9. A full construction SWPPP is also required.

Minimum Requirements per the SWWMM:

- MR-1: Prepare Stormwater Site Plan. MMC 14.15.050 (1)
- MR-2: Stormwater Pollution Prevention Plan (SWPPP). MMC 14.15.050 (2)
- MR-3: Water pollution source control for new development. MMC 14.15.050 (3)
- MR-4: Preservation of natural drainage systems and outfalls. MMC 14.15.050 (4)
- MR-5: On-site stormwater management. MMC 14.15.050 (5)
- MR-6: Runoff treatment. MMC 14.15.050 (6)
- MR-7: Flow control requirements. MMC 14.15.050 (7)
- MR-8: Detention or treatment in wetlands and wetland buffers. MMC 14.15.050 (8)
- MR-9: Inspection, operation and maintenance requirements. MMC 14.15.050 (9)

Each Minimum Requirements is described in the following sections. There are no additional requirements to be met.

2.2 MR #1: Preparation of Stormwater Site Plans

This document is the Stormwater Site Plan Report that addresses the requirements of MR-1. This section presents the portion of the Stormwater Site Plan that includes recommendations, calculations, and procedures required to adhere to Minimum Requirement #1. The evaluation of the existing site conditions follows.

2.2.1 Site Location

The site is located in the SE quarter of Section 19 of Township 31 North, Range 5 East. The street address is 17406 19th Ave NE, Marysville, WA 98271 and the parcel is located to the west of 19th Ave NE. The parcel is also bordered on the west by the Burlington North R.R. See Figure 1 for a vicinity map.

2.2.2 Site Description, Existing Conditions

The project site is 19.52-acres. The parcel owned by Hanson Sisters, LLC. The Snohomish County parcel number is 310519-004-012-00. It is zoned Mixed Use and is located in City of Marysville within Snohomish County.

The parcel is vacant. The existing drainage system(s) are undetermined but largely surface runoff to an on-site wetland over the top silt layer. Surface runoff overall flows east.

The majority of the site is pasture.

All maps and figures are presented in the Support Data section of this document.

A vicinity map that shows the site location is shown as Figure 1.

A site map that shows the property lines is shown in Figure 2.

A topographic map that shows the site boundaries, study area boundaries, and the downstream flow-paths is also presented in Figure 3.

2.2.3 Existing Basin Analysis

The project is defined by the development within the subject parcel. Existing project flow paths are shown in Figure 2.

The study area is located in the Quilceda Creek sub-basin of the Snohomish Basin in the Snohomish watershed (WRIA-7-Snohomish), which drains to the Puget Sound.

All existing flow assessment and site related basin delineations were established by tracing analysis of a LIDAR surface model.

2.2.4 Other Information on the Study Area

The site is not in or adjacent to a USEPA Sole Source Aquifer.

The site is not in a well-head protection area.

The site is not in a floodway or floodplain.

2.2.5 Critical Areas

The area off-site to the north has a small area that may be wetland. The potential wetland is Category IV.

2.2.6 Topography

The site and surrounding topography was analyzed using survey topographic points provided by A.S.P.I. A 3D surface model was generated.

The site has some gently sloped areas with a low point around 116 *feet* MSL along the east boundary. The low point is in the location of the agricultural ditch system. The site slopes up from the east to a high point of 118 *feet* along the west property boundary.

Slopes average in the range of 0 to 5 percent for the majority of the developable area. The site has an average slope of 3.66%.

2.2.7 Soils

The majority of the site is situated on Custer fine sandy loam soils, a hydrologic Type-C/D soil per NRCS mapping. Custer fine sandy loam soils have a 0-9 *inch* first layer of fine sandy loam with the remaining profile being sand. Much surface runoff is attributed to the fine sandy loam layer. Infiltration increases significantly with depth within this soil type in the eastern portion of the site. A narrow band of Kitsap silt loam exists in the west and Norma taxadjunct loam in the north portion of the site. Kitsap soils have limited infiltration capacity due to the fine grained nature of the soils.

Detailed physical and chemical properties of these soils are presented in Section 4.1. The NRCS mapping can be seen in Figure 5.

2.2.8 Field Inspection

The site has not been visited recently. All inspection has been conducted via remote sensing.

2.2.9 Upstream Analysis

A relative high point at 128 *feet* MSL is located along west boundary of the site within the Burlington Northern RR ROW. This local high intercepts all upstream flows from flowing onto the site and adjacent upstream site.

2.2.10 Downstream Analysis

The downstream area was established by tracing analysis of a LIDAR surface model and evaluation of various GIS data, aerial imagery, and City of Marysville Drainage Inventory. The development are flows to the northwest.

The development area flows to the east before reaching an agriculture ditch along the eastern boundary of the site. Stormwater crosses 172nd ROW via a 24" ADS culvert and flows south. After travelling around 580 ft, stormwater turns southeast and flows along the east side of the tracks for two miles downstream of the project site before flowing through a 36 *inch* culvert underneath the RR tracks. The culvert leads stormwater to a ditch that parallels Interstate 5. Stormwater eventually meets with Quilceda Creek near 140th St NE & 29th Ave NE.

Figure 3 shows a portion of the downstream flow path.

2.3 MR #2: Stormwater Pollution Prevention Plans (SWPPPs)

MMC 14.15.050 (2) specifies the requirements for development and redevelopment projects are responsible for preventing erosion and discharge of sediment and other pollutants into receiving waters. Volume I, Chapter 2.5.2 of the 2019 SMMWW specifies that all new development and redevelopment implement a Stormwater Pollution Prevention Plans (SWPPP), which is a list of 13 elements that present measures and methods for all permanent and temporary erosion and sediment control (TESC), pollution prevention, inspection/monitoring activities, and recordkeeping required during the proposed construction project.

Based on the MR#2 thresholds, this project generates more than 2,000 *square feet* of impervious area, so a full SWPPP is required. Required elements for the SWPPP:

- SWPPP element 1: Preserve vegetation/mark clearing limits
- SWPPP element 2: Establish construction access
- SWPPP element 3: Control flow rates
- SWPPP element 4: Install sediment controls
- SWPPP element 5: Stabilize soils
- SWPPP Element 6: Protect slopes
- SWPPP Element 7: Protect permanent drain inlets
- SWPPP element 8: Stabilize channels and outlets
- SWPPP element 9: Control pollutants
- SWWP element 10: Control dewatering
- SWPPP element 11: Maintain best management practices
- SWPPP element 12: Manage the project
- SWPPP element 13: Protect On-Site Stormwater Management BMPs for Runoff from Roofs and Other Hard Surfaces

The SWPPP is assembled as a separate document for portability and reproduction purposes. The document is titled “**Stormwater Pollution Prevention Plan for Hanson Sister, LLC**”, dated 14 November 2023.

2.4 MR #3: Source Control of Pollution

MMC 14.15.050 (3) specifies the requirements for water pollution source control for new development or redevelopment activities in accordance with Volume IV of the SMMWW. These activities are primarily commercial industrial developments that represent significant pollutant generation potential and the associated source control BMPs are designed to suit those activities.

Per Chapter 2.5.3, MR#3 does not apply to residential development, hence such source controls are not specified for this project.

2.5 MR #4: Preservation of Natural Drainage Systems and Outfalls

MMC 14.15.050 (4) specifies the requirements for preservation of natural drainage systems or outfalls for all new development and redevelopment activities under Minimum Requirement 4 in the 2019 SMMWW.

Natural drainage patterns as they once existed shall be retained. Pre-developed conditions experience a sheet drainage pattern to the site's east property boundary. Stormwater generated onsite reaches the property boundary through infiltration or surface runoff prior to being intercepted by exiting ditches. Existing discharge location shall be maintained.

2.6 MR #5: On-Site Stormwater Management

MMC 14.15.050 (5) specifies requirements for on-site stormwater BMPs. This requirement mandates that on-site stormwater runoff be infiltrated, dispersed, and/or retained to the maximum extent feasible without causing flooding or erosion impacts. Projects triggering Minimum Requirements 1 through 5 must use On-site stormwater management BMPs from List #1 for all surfaces or demonstrate compliance with the LID Performance Standard. Projects triggering Minimum Requirements 1 through 9 must meet the requirements of Table 2.5.1 in Vol. 1 of the 2019 SMMWW. Table 2.5.1 specifies the requirements for new or redevelopment depending on UGA and parcel size to meet the requirements of the LID Performance Standard and/or List #2. List #1 and List #2 specify stormwater BMPs in order of preference. The first BMP determined feasible is required.

This project triggers MR's 1-9. This project is within the City's UGA. This project is required to adhere to the LID Performance Standard or List #2 per Table 2.5.1.

List #1 and #2 contain appropriate BMPs to mitigate a particular developed surface. The surfaces included in the list are Lawn and Landscaped Areas, Roofs, and other hard surfaces (road/driveway/parking).

Lawn/Landscape is required to utilize BMP T5.13, Post-Construction Soil Quality and Depth.

Roofs are required to employ BMP T5.30 Full Dispersion or Downspout Infiltration, Rain Gardens or Bioretention, BMP T5.10A Downspout Dispersion Systems, or perforated stub-out connections. The first feasible BMP in this list must be used.

Other Hard surfaces (Roads, Driveways, Parking Lots, Etc.) must utilize BMP T5.30 Full Dispersion, BMP T5.15 Permeable Pavement, Bioretention, Sheet Flow Dispersion, or Concentrated Flow Dispersion. The first feasible BMP in this list must be used.

Lawn/landscape will utilize BMP T5.13, Post Construction Soil Quality and Depth.

Roofs will not be able to provide BMP T5.30 Full Dispersion. Full Dispersion requires 100-foot flow paths within native areas. The project will not be able to maintain 65% open space.

Individual Lot Infiltration is not feasible based on the low-permeability of native soils. Most roofs will be ultimately routed to bioretention areas for treatment and flow control.

BMP T5.10B Downspout Dispersion will not be utilized as each individual lot lacks the prescriptive flow path length. BMP T5.10C perforated stub out connections are also not feasible due to the close proximity of sewer, water, gas, electricity, and cable utilities on these narrow 40 ft wide lots. Perforated stub outs are also not permitted to be installed beneath driveways.

Onsite stormwater BMPs are infeasible.

Road and Driveway/Parking will be routed to bioretention areas, BMP T7.30. The bioretention cells will treat stormwater through filtering, phytoremediation, and microbial action from within the compost.

Permeable pavement will not be used as the pavement areas are likely to have long-term excessive sediment deposition after construction and homeowner turnover. Permeable pavement

may also be constructed over the top of compacted structural fill that does not exhibit infiltration rates consistent with the requirements for this BMP.

A portion of lawn areas along western and northern boundary lines is treated as bypass. The bypassed area flows to a ditch within 19th ROW as existed in years past. The disturbance area within the bypassed area utilizes BMP T5.13.

A site plan showing the stormwater management and development can be seen in Figure 4.

2.7 MR #6: Runoff Treatment

Minimum Requirement #6 in MMC 14.15.050 (6) specifies the requirements for providing runoff treatment. The threshold for requiring a treatment BMP is 5,000 *square feet* of PGIS (Pollution Generating Impervious Surface) or a total of more than $\frac{3}{4}$ of an acre of PGPS (Pollution Generating Pervious Surface).

This project is expected to generate 193,688 *square feet* (4.45 *acres*) of PGIS based on road, sidewalk and driveway areas, therefore treatment facility BMPs are required for this project.

Runoff treatment facility selection is outlined in Vol. I, Ch. 4.2, Step V of the 2019 SMMWW. Step V outlines the treatment facility selection flow chart based on the intended use of a project. Treatment selection is based on if the site is a high-use site, if the downstream receiving waters are phosphorous sensitive, and/or if the site is required to provide enhanced treatment. The definitions of high-use, phosphorous control, and enhanced treatment can be found in Step V in Section 4.2 of the 2019 SMMWW.

The project is not a high use site.

The project is not required to treat for phosphorous.

Enhanced treatment is not required for the project.

Enhanced and Basic treatment is provided through the use of a bioretention facility per Vol. III Section 3.3.12 of the 2019 SMMWW. The bioretention specified will provide enhanced treatment. The bio-cell treats stormwater through the infiltration of stormwater through soils and their ability to absorb pollutants. On-site soils are suitable for use. See Vol III. Section 3.3.12 of the 2019 SMMWW for specific soil design criteria.

The project utilizes bioretention cells for treatment. The bioretention cell mitigates polluted stormwater through physical, chemical and biological treatment processes. The treatment process reduces pollutant loads to downstream receiving waters. Stormwater percolates through compost amended soils and plantings to obtain treatment. The total percolated runoff through each bio-cell's amended soils is well over the 91% total runoff volume treatment requirement. See Section 7.

2.8 MR #7: Flow Control

Minimum Requirement #7 in MMC 14.15.050 (7) specifies the requirements for runoff flow control. The threshold for requiring Minimum Requirement #7 is 5,000 *square feet* of impervious surface. Flow control shall be provided if the project creates more than 10,000 *square feet* of effective impervious area in a threshold discharge area, converts $\frac{3}{4}$ of an acre or more of native vegetation to lawn, 2.5 *acres* or more native vegetation is converted to pasture, or a combination of impervious and converted pervious surfaces cause a 0.1 *cfs* increase in the 100-year flow frequency from a continuous simulation runoff model.

The project exceeds this requirement and is required to provide flow control.

All runoff from impervious surfaces and converted surfaces is preferred to be infiltrated if feasible. Standard flow control requires that stormwater discharges match pre-developed discharge durations for the range of pre-developed discharge rates from 50% of the 2-year peak flow to the 50-year peak flow. The pre-developed condition shall be matched to the fully-forested condition (soils and vegetation) to which the Western Washington Hydrologic Model (WWHM) is calibrated, unless reasonable, historic information is provided that indicates the site was prairie prior to Euro-American settlement. This requirement may also be met by Full dispersion and infiltration. This standard requirement is waived for sites that will reliably infiltrate all the runoff from hard surface and converted vegetation areas.

The project exceeds this requirement and is required to provide flow control.

The site stormwater management practices detention of stormwater generated on site. A small portion of the frontage bypass facilities for detention. The site as a whole still meets the flow control threshold requirement.

The site stormwater management practices combine traditional detention, infiltration and bio-retention for the remaining surfaces. The project uses bioretention cells and rock chambers to manage and treat all incoming impervious surface generated stormwater (PGIS and NPGIS).

Stormwater generated on site flows to Bioretention Cell A, B, D and E. All bioretention cells release stormwater to an existing ditch within 19th Ave NE ROW.

The combination of bioretention cells meet compliance with flow-control standard of 50% of the 2-year to the 50% predeveloped stormwater flows.

All bioretention cells are comprised of 1.5 *feet* of bioretention soil media. Those cells utilize ponded area with freeboard to allow stormwater to percolate through the amended soils. Percolated stormwater drains to a storage chamber consisting of 2.5 *ft* to 3.0 *ft* of rock. The rock layer is drained through a perforated underdrain.

See Section 7 for bioretention cells, planter bioswales and rooftop modeling parameters.

2.9 MR #8: Wetlands Protection

MMC 14.15.050 (8) specifies requirements for discharge of stormwater in wetlands and wetland buffers as well as discharge of stormwater to a stream. The site discharges to an offsite wetland. Any project that is defined within a contributing Threshold Discharge Area which discharges to a critical wetland, Wetlands Protection per MR#8 must be applied.

Minimum Requirement #8 requires that stormwater discharges to wetlands within a projects TDA shall meet a specified Level of Wetland Protection. There are four Wetland Protection Levels that apply to the TDA: General Protection, Protection from Pollutants, Wetland Hydroperiod protection Method 1, and Method 2.

Both General Protection and Protection from Pollutants wetland protection levels are satisfied with the proper implementation of Minimum Requirement #2 and Minimum Requirement #5 & #6, respectively.

Wetland Hydroperiod Protection Methods require monitoring of wetland discharges to maintain existing wetland input volumes. The wetland input volume is a different analysis than the flow rate control of the Stream Protection Duration requirement of Minimum Requirement #7. Minimum Requirement #8 does take precedence over satisfying Minimum Requirement #7. (See Vol. I, Ch.3, Section 3.4.8 of the SMMWW)

The development does not discharge stormwater to wetlands.

2.10 MR # 9: Operation and Maintenance

Minimum Requirement #9 specified MMC 14.15.050 (9) contains requirements for inspection, operation and maintenance of stormwater facilities and BMPs. Specific maintenance standards and requirements are outlined in Volume V of the 2019 SMMWW. The 2019 SMMWW requires the regular maintenance and inspection of drainage facilities.

For portability and reproduction purposes, the Operations and Maintenance Manual is presented in a separate stand-alone document titled “**Operations and Maintenance Manual for English Crossing**”, dated **14 November 2023**. This document will be provided with the construction plan submittal.

Section 3 - Maps & Figures

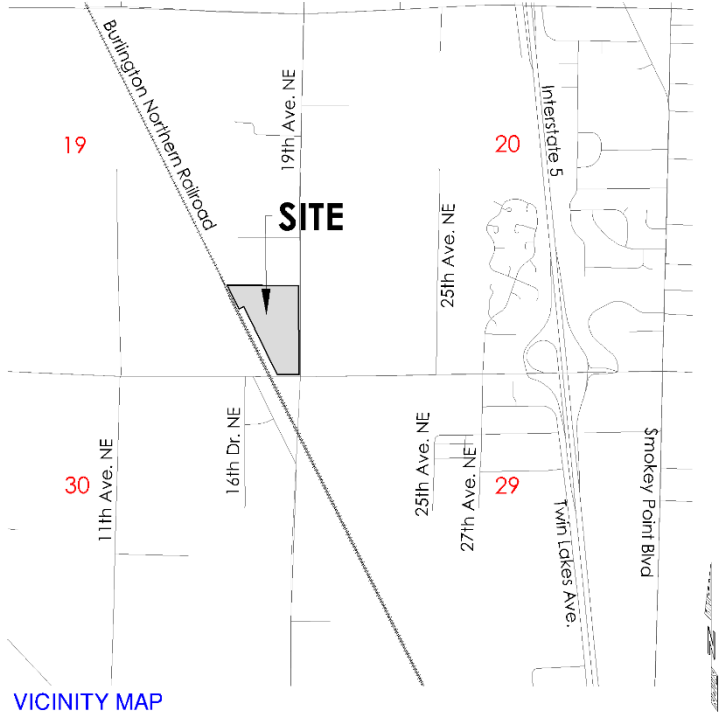

Figure 1 - Vicinity Map



Figure 2 - Existing Conditions (not to scale)

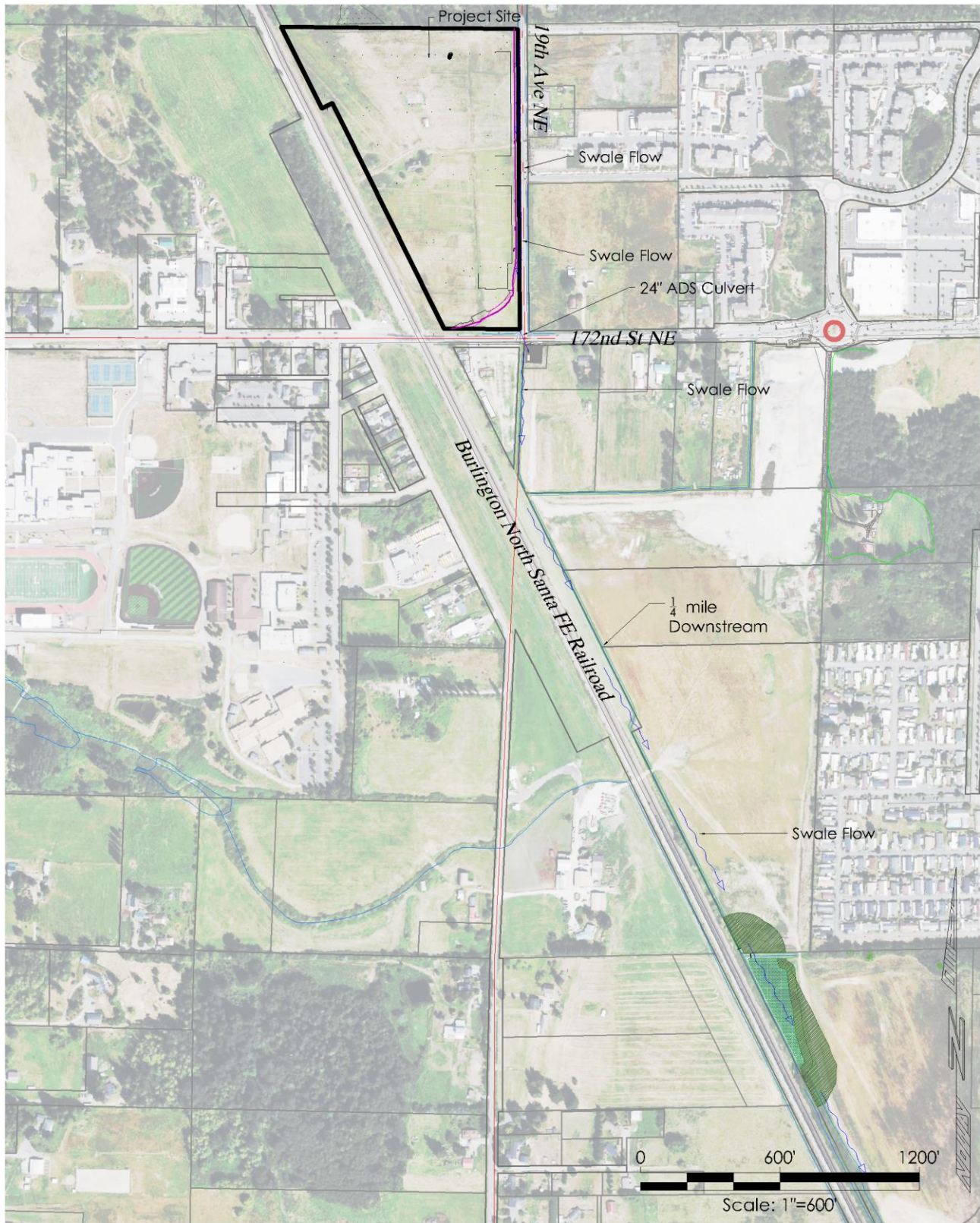

Figure 3 – Downstream Flow Path



Figure 4 - Site Plan

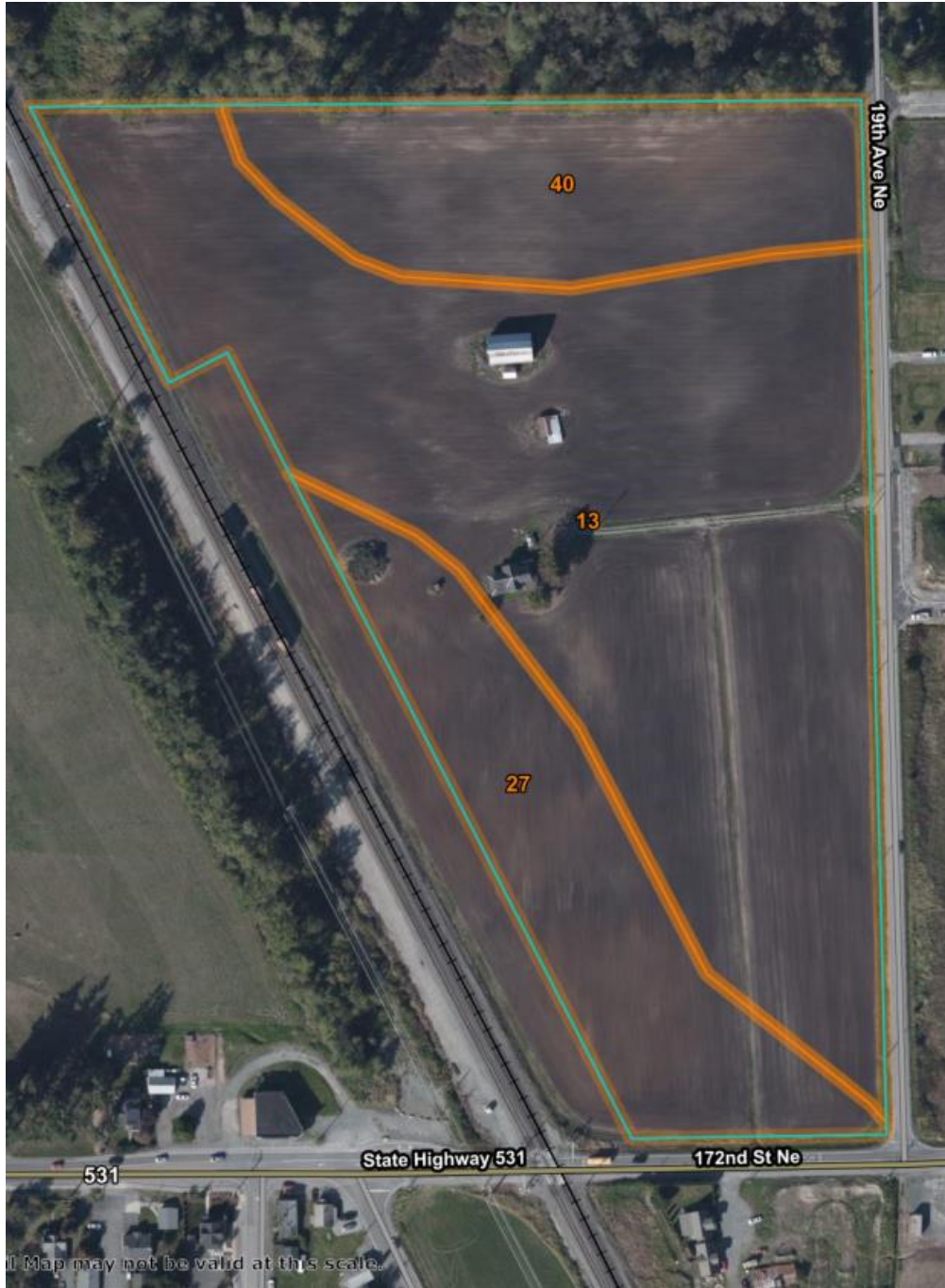

Figure 5 – Soil Map (Not to Scale)

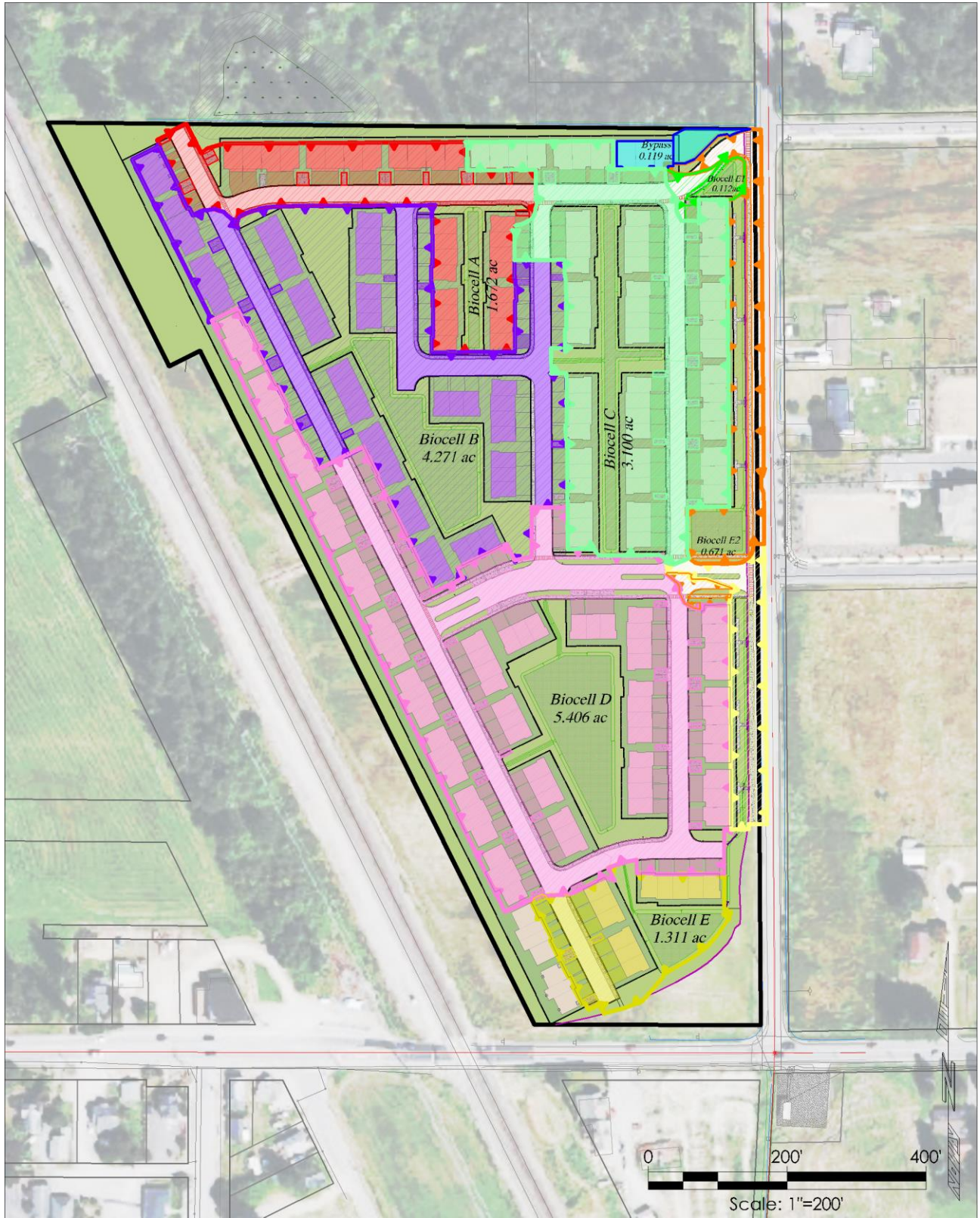

Figure 6 – Basin Map

Section 4 Support Data

4.1 Soils Data

72—Tokul gravelly medial loam, 0 to 8 percent slopes

Map Unit Setting

National map unit symbol: 2t61k

Elevation: 160 to 1,150 feet

Mean annual precipitation: 45 to 70 inches

Mean annual air temperature: 46 to 52 degrees F

Frost-free period: 140 to 200 days

Farmland classification: All areas are prime farmland

Map Unit Composition

Tokul and similar soils: 85 percent

Minor components: 15 percent

Estimates are based on observations, descriptions, and transects of the mapunit.

Description of Tokul

Setting

Landform: Hillslopes, till plains

Landform position (two-dimensional): Toeslope

Landform position (three-dimensional): Side slope, tread

Down-slope shape: Convex

Across-slope shape: Convex

Parent material: Volcanic ash mixed with loess over glacial till

Typical profile

Oi - 0 to 1 inches: slightly decomposed plant material

Oa - 1 to 2 inches: highly decomposed plant material

A - 2 to 6 inches: gravelly medial loam

Bs1 - 6 to 9 inches: gravelly medial loam

Bs2 - 9 to 17 inches: gravelly medial loam

Bs3 - 17 to 24 inches: gravelly medial loam

BC - 24 to 33 inches: gravelly medial fine sandy loam

2Bsm - 33 to 62 inches: cemented material

Properties and qualities

Slope: 0 to 8 percent

Depth to restrictive feature: 20 to 39 inches to densic material; 20 to 39 inches to cemented horizon

Drainage class: Moderately well drained

Capacity of the most limiting layer to transmit water (Ksat): Very low to moderately low (0.00 to 0.06 in/hr)

Depth to water table: About 18 to 36 inches

Frequency of flooding: None

Frequency of ponding: None

Available water supply, 0 to 60 inches: Moderate (about 8.7 inches)

Interpretive groups

Land capability classification (irrigated): None specified

Land capability classification (nonirrigated): 3s

Hydrologic Soil Group: B

Ecological site: F002XA005WA - Puget Lowlands Moist Forest

Forage suitability group: Limited Depth Soils (G002XN302WA), Limited Depth Soils (G002XF303WA)
Other vegetative classification: Limited Depth Soils (G002XN302WA), Limited Depth Soils (G002XF303WA)
Hydric soil rating: No

Minor Components

Pastik

Percent of map unit: 5 percent
Landform: Terraces
Landform position (three-dimensional): Tread
Down-slope shape: Linear
Across-slope shape: Linear
Hydric soil rating: No

Barneston

Percent of map unit: 5 percent
Landform: Moraines, eskers, kames
Landform position (two-dimensional): Summit, shoulder
Landform position (three-dimensional): Crest, interfluve
Down-slope shape: Convex
Across-slope shape: Convex
Hydric soil rating: No

Norma

Percent of map unit: 3 percent
Landform: Drainageways, depressions
Landform position (three-dimensional): Dip
Down-slope shape: Linear, concave
Across-slope shape: Concave
Hydric soil rating: Yes

Mckenna

Percent of map unit: 2 percent
Landform: Drainageways, depressions
Landform position (three-dimensional): Dip
Down-slope shape: Linear, concave
Across-slope shape: Concave
Hydric soil rating: Yes

Section 5 Works Cited

Mays, L. W. (2011). *Water Resources Engineering*. Hoboken: Wiley & Sons, Inc.

Puget Sound Action Team. (2005, January). Low Impact Development Technical Guidance Manual for Puget Sound. *Publication No. PSAT 05-03*. Washington: Washington State University - Pierce County Extension.

Puget Sound LIDAR Consortium. (2003, April). LIDAR Bare Earth DEM File. q47121h24be.e00. Snohomish County, Washington. Retrieved May 2013, from <http://pugetsoundlidar.ess.washington.edu/index.htm>

Snohomish County Planning and Development Services. (2007, October 1). Aquifer Recharge/Wellhead Protection. Everett, WA.

Snohomish County Surface Water Management Division. (2002, December). Snohomish UGA Drainage Needs Report. Everett, Washington.

5.1 Topographic Data

- The various on and off site topography, utilities, and drainage elements were professionally surveyed by Pacific Coast Surveying in 2019.
- Snohomish County 2003 LiDAR survey was used to augment the existing site topography and the downstream and surrounding areas.

The modeled coordinate system:

Lateral - Washington State Plan Plane - North, FIPS 4601;

Vertical – NAVD 88

Section 6 - Continuous Simulation Modeling

6.1 Continuous Simulation Background

HSPF based continuous simulation modeling was used to evaluate the hydrologic performances of the pre-developed and developed sub-basins in order to accurately assess flow rates.

The currently adopted continuous simulation models use the HSPF (Hydraulic Simulation Program in FORTRAN) software engine. The HSPF model uses a robust and detail accounting of the 'water budget', including evaporation, evapotranspiration, interception, interflow, and groundwater. The modeling accounts for and assesses land segment areas that include vegetation or impervious cover, soil types, and slopes. The modeling also uses utilized over 50 years of continuous rainfall data (precipitation) and evaporation data for the area. The HSPF continuous modeling is considered the best available science for hydrologic analysis.

6.2 Modeling Methodology

HSPF modeling was managed via the Western Washington Hydrology Model (WWHM) interface program. The current professional version of WWHM by Clearcreek Solutions, Inc., WWHM-2012 was used. The current data precipitation and evaporation set provided by DOE with the WWHM-2012 software interface was used that includes quantized data in 15-minute time steps from October 1948 to October 2009.

The WWHM program comes packaged with generic, well considered HSPF modeling parameters. These settings allow for the modeling of the majority of the topological conditions found in the Puget Sound area. Where conditions fall reasonably outside the range of the default HSPF parameters, adjustments should be made to more accurately reflect those conditions. These are generally limited to the pervious land segments (IMPLNDS) and are mostly limited to slopes (SLSUR), infiltration rates (INFILT), and length of flow path (LSUR). For this project, HSPF parameters were not adjusted to reflect site conditions.

6.2.1 Existing Conditions

The surface vegetative cover is assumed fully forested with an average slope of 5% in the area of development, based on the LIDAR based TIN analysis. The LIDAR model represents the pre-graded conditions and is in accordance with the predeveloped requirements to be represented as native vegetation and soils that existed at a site prior to the influence of Euro-American settlement.

The NRCS soil mapping of Tokul gravelly medial loam within the modeled area is listed as Type C hydrologic soils. Land segments of Pasture Flat, Mod are representative of the existing site areas. The wetland area itself is modeled in the WWHM as Sat Forest, Flat.

6.2.2 Developed Conditions

Default mapping for flat road was used for the road areas. Roof was for the rooftop areas. Driveway was for the driveway areas and sidewalk for the paths. Pasture was used for the amended soils from DOE recommendations for amended soils modeling. The intent of the modeling of this site was to determine the infiltration and treatment efficiencies of the bio-retention cell. Flow control modeling took place for the bypass area that is unable to be introduced to street system.

It should be noted that when ponds, bio-swales, or other open detention facilities are used, the corresponding WWHM analysis module includes the ponded area. Consequently, this area is not included in the basin land segment mappings so the total area is often different between the developed and pre-developed conditions.

The current DOE specification for amended soils in 2019 is labeled as 'SMMWW' in the Bio-Swale and other WWHM modules that employ amended soils. The parameters for modeling the SMMWW are preset and based on current state-of-the-art modeling using a combination of the Darcy's and Van Genuchten's equations to account for the variability of permeability and water content as the soils transition from dry or partly damp to saturated conditions as the bio-cell cycles through the process of filling, emptying, and drying out. The SMMWW settings based on the WSU amended soils.

Section 7 - Software Output

The following WWHM reports in this section represent individual sub-basin analysis for hydrologic flow evaluations. The following heading is common to all reports.

Western Washington Hydrology Model,

7.1 Biocells A & B

**WWHM2012
PROJECT REPORT**

Project Name: Biocell AB -0727-V3-PASS
Site Name: English Crossing
Site Address: 17406 19th Ave NE
City : Marysville, WA
Report Date: 8/1/2023
MGS Regoin : Puget East
Data Start : 1901/10/1
Data End : 2058/09/30
DOT Data Number: 05
Version Date: 2019/09/13
Version : 4.2.17

Low Flow Threshold for POC 1 : 50 Percent of the 2 Year

High Flow Threshold for POC 1: 50 year

PREDEVELOPED LAND USE

Name : Basin B
Bypass: No

GroundWater: No



<u>Pervious Land Use</u>	<u>acre</u>
C, Forest, Flat	4.271
Pervious Total	4.271
<u>Impervious Land Use</u>	<u>acre</u>
Impervious Total	0
Basin Total	4.271

Element Flows To:
 Surface Interflow Groundwater

Name : Basin A
 Bypass: No

GroundWater: No

<u>Pervious Land Use</u>	<u>acre</u>
C, Forest, Flat	1.672
Pervious Total	1.672
<u>Impervious Land Use</u>	<u>acre</u>
Impervious Total	0
Basin Total	1.672

Element Flows To:
 Surface Interflow Groundwater

MITIGATED LAND USE

Name : Basin B
 Bypass: No

GroundWater: No

<u>Pervious Land Use</u>	<u>acre</u>
C, Pasture, Flat	1.392
Pervious Total	1.392
<u>Impervious Land Use</u>	<u>acre</u>
ROADS FLAT	0.732
DRIVEWAYS FLAT	0.688
SIDEWALKS FLAT	0.108
Impervious Total	1.528
Basin Total	2.92

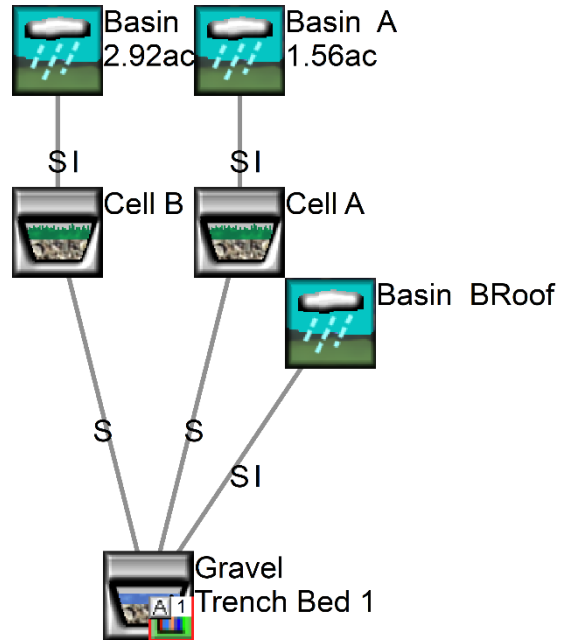

Element Flows To:
 Surface Interflow Groundwater
 Surface Cell B Surface Cell B

Name : Basin A
Bypass: No

GroundWater: No

<u>Pervious Land Use</u>	<u>acre</u>
C, Pasture, Flat	.367
Pervious Total	0.367
<u>Impervious Land Use</u>	<u>acre</u>
ROADS FLAT	0.373
ROOF TOPS FLAT	0.592
DRIVEWAYS FLAT	0.164
DRIVEWAYS MOD	0.062
Impervious Total	1.191
Basin Total	1.558

Element Flows To:

Surface	Interflow	Groundwater
Surface Cell A	Surface Cell A	

Name : Cell B
Bottom Length: 1000.00 ft.
Bottom Width: 16.00 ft.
Material thickness of first layer: 1.5
Material type for first layer: SMMWW 12 in/hr
Material thickness of second layer: 0
Material type for second layer: Sand
Material thickness of third layer: 0
Material type for third layer: GRAVEL
Underdrain used
Underdrain Diameter (feet): 1
Orifice Diameter (in.): 0.9
Offset (in.): 0
Flow Through Underdrain (ac-ft.): 914.024
Total Outflow (ac-ft.): 925.423
Percent Through Underdrain: 98.77
Discharge Structure
Riser Height: 1 ft.
Riser Diameter: 4 in.
Orifice 1 Diameter: 0.2 in. Elevation: 0.05 ft.

Element Flows To:

Outlet 1	Outlet 2
Gravel Trench Bed 1	

Cell B Hydraulic Table

<u>Stage(feet)</u>	<u>Area(ac.)</u>	<u>Volume(ac-ft.)</u>	<u>Discharge(cfs)</u>	<u>Infilt(cfs)</u>
0.0000	0.3673	0.0000	0.0000	0.0000
0.0333	0.3719	0.0056	0.0000	0.0000
0.0667	0.3766	0.0113	0.0000	0.0000
0.1000	0.3812	0.0171	0.0000	0.0000
0.1333	0.3858	0.0230	0.0000	0.0000
0.1667	0.3905	0.0289	0.0000	0.0000
0.2000	0.3951	0.0349	0.0000	0.0000
0.2333	0.3997	0.0409	0.0000	0.0000
0.2667	0.4044	0.0471	0.0000	0.0000
0.3000	0.4090	0.0533	0.0000	0.0000
0.3333	0.4136	0.0595	0.0000	0.0000
0.3667	0.4183	0.0659	0.0000	0.0000
0.4000	0.4229	0.0723	0.0000	0.0000
0.4333	0.4276	0.0788	0.0000	0.0000
0.4667	0.4322	0.0853	0.0000	0.0000
0.5000	0.4368	0.0919	0.0000	0.0000
0.5333	0.4415	0.0986	0.0000	0.0000
0.5667	0.4461	0.1054	0.0000	0.0000
0.6000	0.4508	0.1122	0.0000	0.0000
0.6333	0.4554	0.1191	0.0000	0.0000
0.6667	0.4601	0.1261	0.0000	0.0000
0.7000	0.4647	0.1332	0.0000	0.0000
0.7333	0.4693	0.1403	0.0000	0.0000
0.7667	0.4740	0.1475	0.0000	0.0000
0.8000	0.4786	0.1547	0.0000	0.0000
0.8333	0.4833	0.1621	0.0000	0.0000
0.8667	0.4880	0.1695	0.0000	0.0000
0.9000	0.4926	0.1769	0.0000	0.0000
0.9333	0.4973	0.1845	0.0000	0.0000
0.9667	0.5019	0.1921	0.0000	0.0000
1.0000	0.5066	0.1998	0.0000	0.0000
1.0333	0.5112	0.2075	0.0000	0.0000
1.0667	0.5159	0.2154	0.0000	0.0000
1.1000	0.5205	0.2233	0.0000	0.0000
1.1333	0.5252	0.2312	0.0000	0.0000
1.1667	0.5299	0.2393	0.0000	0.0000
1.2000	0.5345	0.2474	0.0000	0.0000
1.2333	0.5392	0.2556	0.0000	0.0000
1.2667	0.5438	0.2638	0.0000	0.0000
1.3000	0.5485	0.2722	0.0000	0.0000
1.3333	0.5532	0.2805	0.0000	0.0000
1.3667	0.5578	0.2890	0.0000	0.0000
1.4000	0.5625	0.2976	0.0000	0.0000
1.4333	0.5672	0.3062	0.0000	0.0000
1.4667	0.5718	0.3148	0.0000	0.0000
1.5000	0.5765	0.3340	0.0000	0.0000
1.5333	0.5812	0.3533	0.0000	0.0000
1.5667	0.5858	0.3727	0.0000	0.0000
1.6000	0.5905	0.3923	0.0000	0.0000
1.6333	0.5952	0.4121	0.0000	0.0000
1.6667	0.5999	0.4320	0.0000	0.0000
1.7000	0.6045	0.4521	0.0000	0.0000
1.7333	0.6092	0.4723	0.0000	0.0000
1.7667	0.6139	0.4927	0.0000	0.0000

1.8000	0.6186	0.5132	0.0000	0.0000
1.8333	0.6232	0.5339	0.0000	0.0000
1.8667	0.6279	0.5548	0.0000	0.0000
1.9000	0.6326	0.5758	0.0000	0.0000
1.9333	0.6373	0.5970	0.0000	0.0000
1.9667	0.6420	0.6183	0.0000	0.0000
2.0000	0.6466	0.6398	0.0000	0.0000
2.0333	0.6513	0.6614	0.0000	0.0000
2.0667	0.6560	0.6832	0.0000	0.0000
2.1000	0.6607	0.7051	0.0000	0.0000
2.1333	0.6654	0.7272	0.0000	0.0000
2.1667	0.6701	0.7495	0.0000	0.0000
2.2000	0.6748	0.7719	0.0000	0.0000
2.2333	0.6795	0.7945	0.0000	0.0000
2.2667	0.6841	0.8172	0.0000	0.0000
2.3000	0.6888	0.8401	0.0000	0.0000
2.3333	0.6935	0.8631	0.0000	0.0000
2.3667	0.6982	0.8863	0.0000	0.0000
2.4000	0.7029	0.9097	0.0000	0.0000
2.4333	0.7076	0.9332	0.0000	0.0000
2.4667	0.7123	0.9568	0.0000	0.0000
2.5000	0.7170	0.9807	0.0000	0.0000
2.5333	0.7217	1.0046	0.0000	0.0000
2.5667	0.7264	1.0288	0.0000	0.0000
2.6000	0.7311	1.0531	0.0000	0.0000
2.6333	0.7358	1.0775	0.0000	0.0000
2.6667	0.7405	1.1021	0.0000	0.0000
2.7000	0.7452	1.1269	0.0000	0.0000
2.7333	0.7499	1.1518	0.0000	0.0000
2.7667	0.7546	1.1769	0.0000	0.0000
2.8000	0.7593	1.2021	0.0000	0.0000
2.8333	0.7640	1.2275	0.0000	0.0000
2.8667	0.7687	1.2530	0.0000	0.0000
2.9000	0.7734	1.2787	0.0000	0.0000
2.9333	0.7781	1.3046	0.0000	0.0000
2.9667	0.7828	1.3306	0.0000	0.0000

Surface Cell B Hydraulic Table

<u>Stage(feet)</u>	<u>Area(ac.)</u>	<u>Volume(ac-ft.)</u>	<u>Discharge(cfs)</u>	<u>To Amended(cfs)</u>	<u>Wetted Surface</u>
2.9667	0.3673	1.3306	0.0000	0.0000	0.0000
3.0000	0.7876	1.3568	0.0000	0.0000	0.0000
3.0333	0.7923	1.3831	0.0001	0.0000	0.0000
3.0000	0.5791	0.9613	0.0002	7.4074	0.0000

Name : Surface Cell B

Element Flows To:

Outlet 1	Outlet 2
Gravel Trench Bed 1	Cell B

Name : Basin BRoof

Bypass: No

GroundWater: No

<u>Pervious Land Use</u>	<u>acre</u>
Pervious Total	0
<u>Impervious Land Use</u>	<u>acre</u>
ROOF TOPS FLAT	0.985
Impervious Total	0.985
Basin Total	0.985

Element Flows To:		
Surface	Interflow	Groundwater
Gravel Trench Bed 1	Gravel Trench Bed 1	

Name : Cell A
Bottom Length: 100.00 ft.
Bottom Width: 30.00 ft.
Material thickness of first layer: 1.5
Material type for first layer: SMMWW 12 in/hr
Material thickness of second layer: 0
Material type for second layer: Sand
Material thickness of third layer: 0
Material type for third layer: GRAVEL
Underdrain used
Underdrain Diameter (feet): 0.5
Orifice Diameter (in.): 0.9
Offset (in.): 0
Flow Through Underdrain (ac-ft.): 556.494
Total Outflow (ac-ft.): 575.994
Percent Through Underdrain: 96.61
Discharge Structure
Riser Height: 1.5 ft.
Riser Diameter: 6 in.
Orifice 1 Diameter: 0.5 in. **Elevation:** 0.05 ft.

Element Flows To:	
Outlet 1	Outlet 2
Gravel Trench Bed 1	

Cell A Hydraulic Table				
<u>Stage(feet)</u>	<u>Area(ac.)</u>	<u>Volume(ac-ft.)</u>	<u>Discharge(cfs)</u>	<u>Infilt(cfs)</u>
0.0000	0.0689	0.0000	0.0000	0.0000
0.0385	0.0689	0.0012	0.0000	0.0000
0.0769	0.0689	0.0024	0.0000	0.0000
0.1154	0.0689	0.0036	0.0000	0.0000
0.1538	0.0689	0.0048	0.0006	0.0000
0.1923	0.0689	0.0061	0.0051	0.0000
0.2308	0.0689	0.0073	0.0080	0.0000
0.2692	0.0689	0.0085	0.0114	0.0000

0.3077	0.0689	0.0097	0.0122	0.0000
0.3462	0.0689	0.0109	0.0129	0.0000
0.3846	0.0689	0.0121	0.0136	0.0000
0.4231	0.0689	0.0133	0.0143	0.0000
0.4615	0.0689	0.0145	0.0149	0.0000
0.5000	0.0689	0.0157	0.0155	0.0000
0.5385	0.0689	0.0170	0.0161	0.0000
0.5769	0.0689	0.0182	0.0167	0.0000
0.6154	0.0689	0.0194	0.0172	0.0000
0.6538	0.0689	0.0206	0.0178	0.0000
0.6923	0.0689	0.0218	0.0183	0.0000
0.7308	0.0689	0.0230	0.0188	0.0000
0.7692	0.0689	0.0242	0.0193	0.0000
0.8077	0.0689	0.0254	0.0198	0.0000
0.8462	0.0689	0.0266	0.0202	0.0000
0.8846	0.0689	0.0279	0.0207	0.0000
0.9231	0.0689	0.0291	0.0211	0.0000
0.9615	0.0689	0.0303	0.0216	0.0000
1.0000	0.0689	0.0315	0.0220	0.0000
1.0385	0.0689	0.0327	0.0224	0.0000
1.0769	0.0689	0.0339	0.0228	0.0000
1.1154	0.0689	0.0351	0.0232	0.0000
1.1538	0.0689	0.0363	0.0236	0.0000
1.1923	0.0689	0.0376	0.0240	0.0000
1.2308	0.0689	0.0388	0.0244	0.0000
1.2692	0.0689	0.0400	0.0248	0.0000
1.3077	0.0689	0.0412	0.0251	0.0000
1.3462	0.0689	0.0424	0.0255	0.0000
1.3846	0.0689	0.0436	0.0259	0.0000
1.4231	0.0689	0.0448	0.0262	0.0000
1.4615	0.0689	0.0460	0.0266	0.0000
1.5000	0.0689	0.0472	0.0381	0.0000

Surface Cell A Hydraulic Table

<u>Stage(feet)</u>	<u>Area(ac.)</u>	<u>Volume(ac-ft.)</u>	<u>Discharge(cfs)</u>	<u>To Amended(cfs)</u>	<u>Wetted Surface</u>
1.5000	0.0689	0.0472	0.0000	0.8333	0.0000
1.5385	0.0696	0.0499	0.0000	0.8333	0.0000
1.5769	0.0703	0.0526	0.0011	0.8761	0.0000
1.6154	0.0709	0.0553	0.0017	0.8974	0.0000
1.6538	0.0716	0.0581	0.0022	0.9188	0.0000
1.6923	0.0723	0.0608	0.0026	0.9402	0.0000
1.7308	0.0730	0.0636	0.0029	0.9615	0.0000
1.7692	0.0738	0.0664	0.0032	0.9829	0.0000
1.8077	0.0745	0.0693	0.0034	1.0043	0.0000
1.8462	0.0752	0.0722	0.0037	1.0256	0.0000
1.8846	0.0759	0.0751	0.0039	1.0470	0.0000
1.9231	0.0766	0.0780	0.0041	1.0684	0.0000
1.9615	0.0773	0.0810	0.0044	1.0897	0.0000
2.0000	0.0780	0.0839	0.0046	1.1111	0.0000
2.0385	0.0788	0.0870	0.0047	1.1325	0.0000
2.0769	0.0795	0.0900	0.0049	1.1538	0.0000
2.1154	0.0802	0.0931	0.0051	1.1752	0.0000
2.1538	0.0809	0.0962	0.0053	1.1966	0.0000
2.1923	0.0817	0.0993	0.0054	1.2179	0.0000
2.2308	0.0824	0.1025	0.0056	1.2393	0.0000
2.2692	0.0831	0.1056	0.0058	1.2607	0.0000
2.3077	0.0839	0.1089	0.0059	1.2821	0.0000
2.3462	0.0846	0.1121	0.0061	1.3034	0.0000

2.3846	0.0854	0.1154	0.0062	1.3248	0.0000
2.4231	0.0861	0.1187	0.0063	1.3462	0.0000
2.4615	0.0869	0.1220	0.0065	1.3675	0.0000
2.5000	0.0876	0.1253	0.0066	1.3889	0.0000
2.5385	0.0884	0.1287	0.0067	1.4103	0.0000
2.5769	0.0891	0.1321	0.0069	1.4316	0.0000
2.6154	0.0899	0.1356	0.0070	1.4530	0.0000
2.6538	0.0906	0.1391	0.0071	1.4744	0.0000
2.6923	0.0914	0.1426	0.0073	1.4957	0.0000
2.7308	0.0922	0.1461	0.0074	1.5171	0.0000
2.7692	0.0929	0.1496	0.0075	1.5385	0.0000
2.8077	0.0937	0.1532	0.0076	1.5598	0.0000
2.8462	0.0945	0.1568	0.0077	1.5812	0.0000
2.8846	0.0952	0.1605	0.0078	1.6026	0.0000
2.9231	0.0960	0.1642	0.0079	1.6239	0.0000
2.9615	0.0968	0.1679	0.0081	1.6453	0.0000
3.0000	0.0976	0.1716	0.0082	1.6667	0.0000
3.0385	0.0984	0.1754	0.0482	1.6667	0.0000
3.0769	0.0992	0.1792	0.1193	1.6667	0.0000
3.1154	0.1000	0.1830	0.2028	1.6667	0.0000
3.1538	0.1007	0.1869	0.2829	1.6667	0.0000
3.1923	0.1015	0.1908	0.3455	1.6667	0.0000
3.2308	0.1023	0.1947	0.3849	1.6667	0.0000
3.2692	0.1031	0.1986	0.4175	1.6667	0.0000
3.3077	0.1039	0.2026	0.4458	1.6667	0.0000
3.3462	0.1047	0.2066	0.4724	1.6667	0.0000
3.3846	0.1056	0.2107	0.4975	1.6667	0.0000
3.4231	0.1064	0.2148	0.5214	1.6667	0.0000
3.4615	0.1072	0.2189	0.5443	1.6667	0.0000
3.5000	0.1080	0.2230	0.5663	1.6667	0.0000
3.5000	0.1080	0.2230	0.5874	1.6667	0.0000

Name : Surface Cell A

Element Flows To:

Outlet 1	Outlet 2
Gravel Trench Bed 1	Cell A

Name : Gravel Trench Bed 1
Bottom Length: 1040.00 ft.
Bottom Width: 44.00 ft.
Trench bottom slope 1: 0.1 To 1
Trench Left side slope 0: 0.1 To 1
Trench right side slope 2: 0.1 To 1
Material thickness of first layer: 3
Pour Space of material for first layer: 0.42
Material thickness of second layer: 0
Pour Space of material for second layer: 0
Material thickness of third layer: 0
Pour Space of material for third layer: 0
Discharge Structure
Riser Height: 2.7 ft.
Riser Diameter: 12 in.
Notch Type: Rectangular
Notch Width: 0.060 ft.

Notch Height: 0.570 ft.

Orifice 1 Diameter: 1.2 in. Elevation: 0 ft.

Element Flows To:

Outlet 1

Outlet 2

Gravel Trench Bed Hydraulic Table

<u>Stage(feet)</u>	<u>Area(ac.)</u>	<u>Volume(ac-ft.)</u>	<u>Discharge(cfs)</u>	<u>Infil(cfs)</u>
0.0000	1.050	0.000	0.000	0.000
0.0333	1.050	0.014	0.007	0.000
0.0667	1.050	0.029	0.010	0.000
0.1000	1.051	0.044	0.012	0.000
0.1333	1.051	0.058	0.014	0.000
0.1667	1.051	0.073	0.016	0.000
0.2000	1.051	0.088	0.017	0.000
0.2333	1.051	0.103	0.018	0.000
0.2667	1.051	0.117	0.020	0.000
0.3000	1.052	0.132	0.021	0.000
0.3333	1.052	0.147	0.022	0.000
0.3667	1.052	0.161	0.023	0.000
0.4000	1.052	0.176	0.024	0.000
0.4333	1.052	0.191	0.025	0.000
0.4667	1.052	0.206	0.026	0.000
0.5000	1.053	0.220	0.027	0.000
0.5333	1.053	0.235	0.028	0.000
0.5667	1.053	0.250	0.029	0.000
0.6000	1.053	0.265	0.030	0.000
0.6333	1.053	0.279	0.031	0.000
0.6667	1.053	0.294	0.031	0.000
0.7000	1.054	0.309	0.032	0.000
0.7333	1.054	0.324	0.033	0.000
0.7667	1.054	0.338	0.034	0.000
0.8000	1.054	0.353	0.035	0.000
0.8333	1.054	0.368	0.035	0.000
0.8667	1.054	0.383	0.036	0.000
0.9000	1.055	0.397	0.037	0.000
0.9333	1.055	0.412	0.037	0.000
0.9667	1.055	0.427	0.038	0.000
1.0000	1.055	0.442	0.039	0.000
1.0333	1.055	0.457	0.039	0.000
1.0667	1.055	0.471	0.040	0.000
1.1000	1.056	0.486	0.041	0.000
1.1333	1.056	0.501	0.041	0.000
1.1667	1.056	0.516	0.042	0.000
1.2000	1.056	0.531	0.042	0.000
1.2333	1.056	0.545	0.043	0.000
1.2667	1.056	0.560	0.044	0.000
1.3000	1.057	0.575	0.044	0.000
1.3333	1.057	0.590	0.045	0.000
1.3667	1.057	0.604	0.045	0.000
1.4000	1.057	0.619	0.046	0.000
1.4333	1.057	0.634	0.046	0.000
1.4667	1.057	0.649	0.047	0.000
1.5000	1.058	0.664	0.047	0.000

1.5333	1.058	0.679	0.048	0.000
1.5667	1.058	0.693	0.048	0.000
1.6000	1.058	0.708	0.049	0.000
1.6333	1.058	0.723	0.049	0.000
1.6667	1.058	0.738	0.050	0.000
1.7000	1.059	0.753	0.051	0.000
1.7333	1.059	0.767	0.051	0.000
1.7667	1.059	0.782	0.051	0.000
1.8000	1.059	0.797	0.052	0.000
1.8333	1.059	0.812	0.052	0.000
1.8667	1.059	0.827	0.053	0.000
1.9000	1.060	0.842	0.053	0.000
1.9333	1.060	0.856	0.054	0.000
1.9667	1.060	0.871	0.054	0.000
2.0000	1.060	0.886	0.055	0.000
2.0333	1.060	0.901	0.055	0.000
2.0667	1.060	0.916	0.056	0.000
2.1000	1.061	0.931	0.056	0.000
2.1333	1.061	0.946	0.057	0.000
2.1667	1.061	0.960	0.058	0.000
2.2000	1.061	0.975	0.061	0.000
2.2333	1.061	0.990	0.064	0.000
2.2667	1.061	1.005	0.068	0.000
2.3000	1.062	1.020	0.072	0.000
2.3333	1.062	1.035	0.077	0.000
2.3667	1.062	1.050	0.082	0.000
2.4000	1.062	1.064	0.087	0.000
2.4333	1.062	1.079	0.092	0.000
2.4667	1.062	1.094	0.097	0.000
2.5000	1.063	1.109	0.103	0.000
2.5333	1.063	1.124	0.109	0.000
2.5667	1.063	1.139	0.115	0.000
2.6000	1.063	1.154	0.121	0.000
2.6333	1.063	1.169	0.127	0.000
2.6667	1.063	1.184	0.133	0.000
2.7000	1.063	1.198	0.140	0.000
2.7333	1.064	1.213	0.205	0.000
2.7667	1.064	1.228	0.323	0.000
2.8000	1.064	1.243	0.475	0.000
2.8333	1.064	1.258	0.651	0.000
2.8667	1.064	1.273	0.845	0.000
2.9000	1.064	1.288	1.050	0.000
2.9333	1.065	1.303	1.258	0.000
2.9667	1.065	1.318	1.461	0.000
3.0000	1.065	1.333	1.653	0.000

ANALYSIS RESULTS

Stream Protection Duration

Predeveloped Landuse Totals for POC #1
Total Pervious Area:5.943
Total Impervious Area:0

Mitigated Landuse Totals for POC #1
 Total Pervious Area:1.759
 Total Impervious Area:3.704

Flow Frequency Return Periods for Predeveloped. POC #1

<u>Return Period</u>	<u>Flow(cfs)</u>
2 year	0.128478
5 year	0.188942
10 year	0.220578
25 year	0.25211
50 year	0.270577
100 year	0.285626

Flow Frequency Return Periods for Mitigated. POC #1

<u>Return Period</u>	<u>Flow(cfs)</u>
2 year	0.056122
5 year	0.097638
10 year	0.139458
25 year	0.215214
50 year	0.293639
100 year	0.396521

Stream Protection Duration

POC #1

The Facility PASSED

The Facility **PASSED.**

Flow(cfs)	Predev	Mit	Percentage	Pass/Fail
0.0642	55436	23418	42	Pass
0.0663	51125	21387	41	Pass
0.0684	47321	19576	41	Pass
0.0705	43809	17902	40	Pass
0.0726	40589	16405	40	Pass
0.0747	37737	15139	40	Pass
0.0767	35205	13884	39	Pass
0.0788	32788	12816	39	Pass
0.0809	30542	11962	39	Pass
0.0830	28522	11159	39	Pass
0.0851	26617	10416	39	Pass
0.0872	24938	9689	38	Pass
0.0892	23325	9050	38	Pass
0.0913	21844	8571	39	Pass
0.0934	20501	8114	39	Pass
0.0955	19207	7652	39	Pass
0.0976	17974	7190	40	Pass
0.0997	16867	6689	39	Pass
0.1018	15843	6254	39	Pass
0.1038	14864	5857	39	Pass
0.1059	13955	5443	39	Pass
0.1080	13074	5090	38	Pass
0.1101	12348	4792	38	Pass
0.1122	11627	4515	38	Pass
0.1143	11005	4257	38	Pass

0.1163	10371	4008	38	Pass
0.1184	9810	3767	38	Pass
0.1205	9215	3533	38	Pass
0.1226	8747	3256	37	Pass
0.1247	8280	3048	36	Pass
0.1268	7823	2882	36	Pass
0.1288	7371	2702	36	Pass
0.1309	6997	2519	36	Pass
0.1330	6634	2295	34	Pass
0.1351	6331	2120	33	Pass
0.1372	6078	1922	31	Pass
0.1393	5813	1689	29	Pass
0.1414	5560	1507	27	Pass
0.1434	5314	1456	27	Pass
0.1455	5087	1417	27	Pass
0.1476	4865	1387	28	Pass
0.1497	4670	1356	29	Pass
0.1518	4431	1318	29	Pass
0.1539	4204	1296	30	Pass
0.1559	4017	1267	31	Pass
0.1580	3846	1235	32	Pass
0.1601	3687	1211	32	Pass
0.1622	3536	1187	33	Pass
0.1643	3393	1161	34	Pass
0.1664	3272	1136	34	Pass
0.1685	3150	1117	35	Pass
0.1705	3050	1087	35	Pass
0.1726	2961	1063	35	Pass
0.1747	2878	1047	36	Pass
0.1768	2797	1033	36	Pass
0.1789	2719	1014	37	Pass
0.1810	2636	990	37	Pass
0.1830	2502	971	38	Pass
0.1851	2414	947	39	Pass
0.1872	2318	929	40	Pass
0.1893	2206	901	40	Pass
0.1914	2103	881	41	Pass
0.1935	2000	857	42	Pass
0.1955	1911	832	43	Pass
0.1976	1834	813	44	Pass
0.1997	1763	794	45	Pass
0.2018	1701	774	45	Pass
0.2039	1634	746	45	Pass
0.2060	1571	728	46	Pass
0.2081	1503	710	47	Pass
0.2101	1444	694	48	Pass
0.2122	1387	679	48	Pass
0.2143	1320	659	49	Pass
0.2164	1266	639	50	Pass
0.2185	1223	626	51	Pass
0.2206	1169	610	52	Pass
0.2226	1116	588	52	Pass
0.2247	1065	571	53	Pass
0.2268	1025	555	54	Pass
0.2289	993	539	54	Pass
0.2310	956	523	54	Pass
0.2331	922	500	54	Pass
0.2351	880	481	54	Pass

0.2372	818	464	56	Pass
0.2393	755	443	58	Pass
0.2414	719	424	58	Pass
0.2435	687	408	59	Pass
0.2456	644	397	61	Pass
0.2477	607	391	64	Pass
0.2497	561	379	67	Pass
0.2518	526	369	70	Pass
0.2539	485	354	72	Pass
0.2560	456	340	74	Pass
0.2581	427	331	77	Pass
0.2602	394	322	81	Pass
0.2622	367	315	85	Pass
0.2643	350	307	87	Pass
0.2664	333	301	90	Pass
0.2685	317	295	93	Pass
0.2706	299	288	96	Pass

7.2 Biocell C

WWHM2012
PROJECT REPORT

Project Name: Biocell C 1102
Site Name: English Crossing
Site Address: 17406 19th Ave NE
City : Marysville, WA
Report Date: 11/2/2023
MGS Regoin : Puget East
Data Start : 1901/10/1
Data End : 2058/09/30
DOT Data Number: 05
Version Date: 2023/01/27
Version : 4.2.19

Low Flow Threshold for POC 1 : 50 Percent of the 2 Year

High Flow Threshold for POC 1: 50 year

PREDEVELOPED LAND USE

Name : Basin C

Bypass: No

GroundWater: No

<u>Pervious Land Use</u>	<u>acre</u>
C, Forest, Flat	3.1

Pervious Total	3.1
-----------------------	------------

<u>Impervious Land Use</u>	<u>acre</u>
Impervious Total	0

Basin Total	3.1
--------------------	------------



Element Flows To:

Surface

Interflow

Groundwater

MITIGATED LAND USE

Name : Basin C
 Bypass: No

GroundWater: No

Pervious Land Use acre
 C, Pasture, Flat .712

Pervious Total 0.712

Impervious Land Use acre
 ROADS FLAT 0.504
 DRIVEWAYS FLAT 0.425
 SIDEWALKS FLAT 0.083

Impervious Total 1.012

Basin Total 1.724

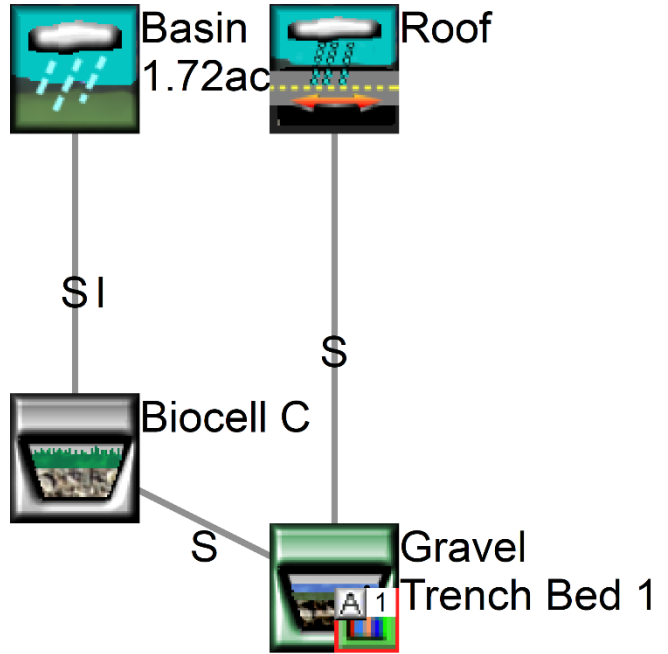

Element Flows To:

Surface	Interflow	Groundwater
Surface Biocell C	Surface Biocell C	

Name : Biocell C

Bottom Length: 115.00 ft.

Bottom Width: 70.00 ft.

Material thickness of first layer: 1.5

Material type for first layer: SMMWW 12 in/hr

Material thickness of second layer: 0

Material type for second layer: Sand

Material thickness of third layer: 0

Material type for third layer: GRAVEL

Underdrain used

Underdrain Diameter (feet): 0.5

Orifice Diameter (in.): 0.7

Offset (in.): 0

Flow Through Underdrain (ac-ft.): 558.847

Total Outflow (ac-ft.): 570.274

Percent Through Underdrain: 98

Discharge Structure

Riser Height: 1 ft.

Riser Diameter: 4 in.

Orifice 1 Diameter: 0.2 in. Elevation: 0.02 ft.

Element Flows To:

Outlet 1	Outlet 2
Gravel Trench Bed 1	

Biocell C Hydraulic Table

<u>Stage(feet)</u>	<u>Area(ac.)</u>	<u>Volume(ac-ft.)</u>	<u>Discharge(cfs)</u>	<u>Infilt(cfs)</u>
0.0000	0.1848	0.0000	0.0000	0.0000
0.0330	0.1848	0.0028	0.0000	0.0000
0.0659	0.1848	0.0056	0.0000	0.0000
0.0989	0.1848	0.0084	0.0000	0.0000
0.1319	0.1848	0.0111	0.0000	0.0000
0.1648	0.1848	0.0139	0.0054	0.0000
0.1978	0.1848	0.0167	0.0059	0.0000
0.2308	0.1848	0.0195	0.0064	0.0000
0.2637	0.1848	0.0223	0.0068	0.0000
0.2967	0.1848	0.0251	0.0072	0.0000
0.3297	0.1848	0.0279	0.0076	0.0000
0.3626	0.1848	0.0306	0.0080	0.0000
0.3956	0.1848	0.0334	0.0084	0.0000
0.4286	0.1848	0.0362	0.0087	0.0000
0.4615	0.1848	0.0390	0.0090	0.0000
0.4945	0.1848	0.0418	0.0094	0.0000
0.5275	0.1848	0.0446	0.0097	0.0000
0.5604	0.1848	0.0474	0.0100	0.0000
0.5934	0.1848	0.0501	0.0102	0.0000
0.6264	0.1848	0.0529	0.0105	0.0000
0.6593	0.1848	0.0557	0.0108	0.0000
0.6923	0.1848	0.0585	0.0111	0.0000
0.7253	0.1848	0.0613	0.0113	0.0000
0.7582	0.1848	0.0641	0.0116	0.0000
0.7912	0.1848	0.0669	0.0118	0.0000
0.8242	0.1848	0.0697	0.0121	0.0000
0.8571	0.1848	0.0724	0.0123	0.0000
0.8901	0.1848	0.0752	0.0125	0.0000
0.9231	0.1848	0.0780	0.0128	0.0000
0.9560	0.1848	0.0808	0.0130	0.0000
0.9890	0.1848	0.0836	0.0132	0.0000
1.0220	0.1848	0.0864	0.0134	0.0000
1.0549	0.1848	0.0892	0.0137	0.0000
1.0879	0.1848	0.0919	0.0139	0.0000
1.1209	0.1848	0.0947	0.0141	0.0000
1.1538	0.1848	0.0975	0.0143	0.0000
1.1868	0.1848	0.1003	0.0145	0.0000
1.2198	0.1848	0.1031	0.0147	0.0000
1.2527	0.1848	0.1059	0.0149	0.0000
1.2857	0.1848	0.1087	0.0151	0.0000
1.3187	0.1848	0.1114	0.0153	0.0000
1.3516	0.1848	0.1142	0.0155	0.0000
1.3846	0.1848	0.1170	0.0156	0.0000
1.4176	0.1848	0.1198	0.0158	0.0000
1.4505	0.1848	0.1226	0.0160	0.0000
1.4835	0.1848	0.1254	0.0162	0.0000
1.5000	0.1848	0.1268	0.0210	0.0000

Surface Biocell C Hydraulic Table

<u>Stage(feet)</u>	<u>Area(ac.)</u>	<u>Volume(ac-ft.)</u>	<u>Discharge(cfs)</u>	<u>To Amended(cfs)</u>	<u>Wetted Surface</u>
1.5000	0.1848	0.1268	0.0000	2.2361	0.0000
1.5330	0.1856	0.1329	0.0001	2.2361	0.0000
1.5659	0.1865	0.1390	0.0002	2.3344	0.0000
1.5989	0.1873	0.1452	0.0003	2.3835	0.0000
1.6319	0.1882	0.1514	0.0004	2.4327	0.0000
1.6648	0.1890	0.1576	0.0004	2.4818	0.0000

1.6978	0.1899	0.1638	0.0005	2.5310	0.0000
1.7308	0.1907	0.1701	0.0005	2.5801	0.0000
1.7637	0.1916	0.1764	0.0005	2.6293	0.0000
1.7967	0.1924	0.1827	0.0006	2.6784	0.0000
1.8297	0.1933	0.1891	0.0006	2.7276	0.0000
1.8626	0.1942	0.1955	0.0006	2.7767	0.0000
1.8956	0.1950	0.2019	0.0007	2.8259	0.0000
1.9286	0.1959	0.2083	0.0007	2.8750	0.0000
1.9615	0.1967	0.2148	0.0007	2.9241	0.0000
1.9945	0.1976	0.2213	0.0007	2.9733	0.0000
2.0275	0.1985	0.2278	0.0008	3.0224	0.0000
2.0604	0.1993	0.2344	0.0008	3.0716	0.0000
2.0934	0.2002	0.2410	0.0008	3.1207	0.0000
2.1264	0.2011	0.2476	0.0008	3.1699	0.0000
2.1593	0.2020	0.2542	0.0009	3.2190	0.0000
2.1923	0.2028	0.2609	0.0009	3.2682	0.0000
2.2253	0.2037	0.2676	0.0009	3.3173	0.0000
2.2582	0.2046	0.2743	0.0009	3.3665	0.0000
2.2912	0.2055	0.2811	0.0010	3.4156	0.0000
2.3242	0.2064	0.2879	0.0010	3.4647	0.0000
2.3571	0.2073	0.2947	0.0010	3.5139	0.0000
2.3901	0.2081	0.3015	0.0010	3.5630	0.0000
2.4231	0.2090	0.3084	0.0010	3.6122	0.0000
2.4560	0.2099	0.3153	0.0011	3.6613	0.0000
2.4890	0.2108	0.3223	0.0011	3.7105	0.0000
2.5220	0.2117	0.3292	0.0126	3.7269	0.0000
2.5549	0.2126	0.3362	0.0455	3.7269	0.0000
2.5879	0.2135	0.3432	0.0846	3.7269	0.0000
2.6209	0.2144	0.3503	0.1177	3.7269	0.0000
2.6538	0.2153	0.3574	0.1376	3.7269	0.0000
2.6868	0.2162	0.3645	0.1524	3.7269	0.0000
2.7198	0.2171	0.3716	0.1653	3.7269	0.0000
2.7527	0.2180	0.3788	0.1771	3.7269	0.0000
2.7857	0.2189	0.3860	0.1883	3.7269	0.0000
2.8187	0.2198	0.3932	0.1988	3.7269	0.0000
2.8516	0.2208	0.4005	0.2088	3.7269	0.0000
2.8846	0.2217	0.4078	0.2183	3.7269	0.0000
2.9176	0.2226	0.4151	0.2274	3.7269	0.0000
2.9505	0.2235	0.4225	0.2362	3.7269	0.0000
2.9835	0.2244	0.4299	0.2447	3.7269	0.0000
3.0000	0.2249	0.4336	0.2528	3.7269	0.0000

Name : Surface Biocell C

Element Flows To:

Outlet 1	Outlet 2
Gravel Trench Bed 1	Biocell C

Name : Roof

Bypass: No

<u>Impervious Land Use</u>	<u>acre</u>
ROOF TOPS FLAT LAT	1.154

Element Flows To:
Outlet 1 **Outlet 2**
 Gravel Trench Bed 1

Name : Gravel Trench Bed 1
Bottom Length: 1000.00 ft.
Bottom Width: 20.00 ft.
Trench bottom slope 1: 0.1 To 1
Trench Left side slope 0: 0.1 To 1
Trench right side slope 2: 0.1 To 1
Material thickness of first layer: 3
Pour Space of material for first layer: 0.48
Material thickness of second layer: 0
Pour Space of material for second layer: 0
Material thickness of third layer: 0
Pour Space of material for third layer: 0
Discharge Structure
Riser Height: 2.8 ft.
Riser Diameter: 18 in.
Notch Type: Rectangular
Notch Width: 0.030 ft.
Notch Height: 0.960 ft.
Orifice 1 Diameter: 0.98 in. **Elevation:** 0 ft.

Element Flows To:
Outlet 1 **Outlet 2**

Gravel Trench Bed Hydraulic Table

<u>Stage(feet)</u>	<u>Area(ac.)</u>	<u>Volume(ac-ft.)</u>	<u>Discharge(cfs)</u>	<u>Infilt(cfs)</u>
0.0000	0.459	0.000	0.000	0.000
0.0333	0.459	0.007	0.004	0.000
0.0667	0.459	0.014	0.006	0.000
0.1000	0.459	0.022	0.008	0.000
0.1333	0.459	0.029	0.009	0.000
0.1667	0.459	0.036	0.010	0.000
0.2000	0.460	0.044	0.011	0.000
0.2333	0.460	0.051	0.012	0.000
0.2667	0.460	0.058	0.013	0.000
0.3000	0.460	0.066	0.014	0.000
0.3333	0.460	0.073	0.015	0.000
0.3667	0.460	0.081	0.015	0.000
0.4000	0.461	0.088	0.016	0.000
0.4333	0.461	0.095	0.017	0.000
0.4667	0.461	0.103	0.017	0.000
0.5000	0.461	0.110	0.018	0.000
0.5333	0.461	0.117	0.019	0.000
0.5667	0.461	0.125	0.019	0.000
0.6000	0.461	0.132	0.020	0.000
0.6333	0.462	0.140	0.020	0.000
0.6667	0.462	0.147	0.021	0.000
0.7000	0.462	0.154	0.021	0.000
0.7333	0.462	0.162	0.022	0.000

0.7667	0.462	0.169	0.022	0.000
0.8000	0.462	0.177	0.023	0.000
0.8333	0.463	0.184	0.023	0.000
0.8667	0.463	0.191	0.024	0.000
0.9000	0.463	0.199	0.024	0.000
0.9333	0.463	0.206	0.025	0.000
0.9667	0.463	0.214	0.025	0.000
1.0000	0.463	0.221	0.026	0.000
1.0333	0.464	0.228	0.026	0.000
1.0667	0.464	0.236	0.026	0.000
1.1000	0.464	0.243	0.027	0.000
1.1333	0.464	0.251	0.027	0.000
1.1667	0.464	0.258	0.028	0.000
1.2000	0.464	0.266	0.028	0.000
1.2333	0.464	0.273	0.028	0.000
1.2667	0.465	0.281	0.029	0.000
1.3000	0.465	0.288	0.029	0.000
1.3333	0.465	0.295	0.030	0.000
1.3667	0.465	0.303	0.030	0.000
1.4000	0.465	0.310	0.030	0.000
1.4333	0.465	0.318	0.031	0.000
1.4667	0.466	0.325	0.031	0.000
1.5000	0.466	0.333	0.031	0.000
1.5333	0.466	0.340	0.032	0.000
1.5667	0.466	0.348	0.032	0.000
1.6000	0.466	0.355	0.033	0.000
1.6333	0.466	0.363	0.033	0.000
1.6667	0.466	0.370	0.033	0.000
1.7000	0.467	0.377	0.034	0.000
1.7333	0.467	0.385	0.034	0.000
1.7667	0.467	0.392	0.034	0.000
1.8000	0.467	0.400	0.035	0.000
1.8333	0.467	0.407	0.035	0.000
1.8667	0.467	0.415	0.036	0.000
1.9000	0.468	0.422	0.037	0.000
1.9333	0.468	0.430	0.039	0.000
1.9667	0.468	0.437	0.040	0.000
2.0000	0.468	0.445	0.043	0.000
2.0333	0.468	0.452	0.045	0.000
2.0667	0.468	0.460	0.047	0.000
2.1000	0.469	0.467	0.050	0.000
2.1333	0.469	0.475	0.053	0.000
2.1667	0.469	0.482	0.055	0.000
2.2000	0.469	0.490	0.058	0.000
2.2333	0.469	0.497	0.061	0.000
2.2667	0.469	0.505	0.064	0.000
2.3000	0.469	0.512	0.067	0.000
2.3333	0.470	0.520	0.071	0.000
2.3667	0.470	0.527	0.074	0.000
2.4000	0.470	0.535	0.077	0.000
2.4333	0.470	0.542	0.080	0.000
2.4667	0.470	0.550	0.084	0.000
2.5000	0.470	0.558	0.087	0.000
2.5333	0.471	0.565	0.091	0.000
2.5667	0.471	0.573	0.094	0.000
2.6000	0.471	0.580	0.098	0.000
2.6333	0.471	0.588	0.101	0.000
2.6667	0.471	0.595	0.105	0.000

2.7000	0.471	0.603	0.108	0.000
2.7333	0.471	0.610	0.112	0.000
2.7667	0.472	0.618	0.115	0.000
2.8000	0.472	0.625	0.119	0.000
2.8333	0.472	0.633	0.216	0.000
2.8667	0.472	0.641	0.393	0.000
2.9000	0.472	0.648	0.622	0.000
2.9333	0.472	0.656	0.892	0.000
2.9667	0.473	0.663	1.195	0.000
3.0000	0.473	0.671	1.525	0.000

ANALYSIS RESULTS

Stream Protection Duration

Predeveloped Landuse Totals for POC #1

Total Pervious Area:3.1

Total Impervious Area:0

Mitigated Landuse Totals for POC #1

Total Pervious Area:0.712

Total Impervious Area:2.166

Flow Frequency Return Periods for Predeveloped. POC #1

<u>Return Period</u>	<u>Flow(cfs)</u>
2 year	0.067017
5 year	0.098556
10 year	0.115058
25 year	0.131506
50 year	0.141139
100 year	0.148989

Flow Frequency Return Periods for Mitigated. POC #1

<u>Return Period</u>	<u>Flow(cfs)</u>
2 year	0.036271
5 year	0.065622
10 year	0.096121
25 year	0.152957
50 year	0.21333
100 year	0.294258

Stream Protection Duration

POC #1

The Facility PASSED

The Facility PASSED.

Flow(cfs)	Predev	Mit	Percentage	Pass/Fail
0.0335	55491	46451	83	Pass
0.0346	51142	33151	64	Pass
0.0357	47316	24905	52	Pass

0.0368	43803	22015	50	Pass
0.0379	40594	19868	48	Pass
0.0389	37748	18200	48	Pass
0.0400	35199	17044	48	Pass
0.0411	32799	15921	48	Pass
0.0422	30558	14908	48	Pass
0.0433	28522	14010	49	Pass
0.0444	26617	13245	49	Pass
0.0455	24949	12546	50	Pass
0.0466	23325	11836	50	Pass
0.0476	21844	11115	50	Pass
0.0487	20506	10460	51	Pass
0.0498	19213	9904	51	Pass
0.0509	17974	9430	52	Pass
0.0520	16867	8990	53	Pass
0.0531	15821	8560	54	Pass
0.0542	14853	8158	54	Pass
0.0553	13939	7801	55	Pass
0.0563	13080	7454	56	Pass
0.0574	12320	7101	57	Pass
0.0585	11610	6793	58	Pass
0.0596	10983	6441	58	Pass
0.0607	10360	6105	58	Pass
0.0618	9804	5797	59	Pass
0.0629	9210	5538	60	Pass
0.0639	8736	5319	60	Pass
0.0650	8252	5128	62	Pass
0.0661	7812	4936	63	Pass
0.0672	7355	4752	64	Pass
0.0683	6991	4586	65	Pass
0.0694	6634	4406	66	Pass
0.0705	6331	4261	67	Pass
0.0716	6067	4136	68	Pass
0.0726	5808	3995	68	Pass
0.0737	5555	3874	69	Pass
0.0748	5309	3740	70	Pass
0.0759	5087	3611	70	Pass
0.0770	4865	3497	71	Pass
0.0781	4665	3360	72	Pass
0.0792	4426	3180	71	Pass
0.0803	4201	3070	73	Pass
0.0813	4012	2969	74	Pass
0.0824	3845	2873	74	Pass
0.0835	3687	2789	75	Pass
0.0846	3530	2698	76	Pass
0.0857	3389	2608	76	Pass
0.0868	3267	2526	77	Pass
0.0879	3150	2446	77	Pass
0.0890	3050	2344	76	Pass
0.0900	2961	2265	76	Pass
0.0911	2879	2172	75	Pass
0.0922	2794	2066	73	Pass
0.0933	2716	1972	72	Pass
0.0944	2635	1893	71	Pass
0.0955	2502	1811	72	Pass
0.0966	2413	1709	70	Pass
0.0977	2318	1612	69	Pass
0.0987	2200	1517	68	Pass

0.0998	2100	1442	68	Pass
0.1009	1998	1378	68	Pass
0.1020	1909	1295	67	Pass
0.1031	1840	1239	67	Pass
0.1042	1766	1182	66	Pass
0.1053	1702	1121	65	Pass
0.1063	1634	1062	64	Pass
0.1074	1571	1011	64	Pass
0.1085	1503	954	63	Pass
0.1096	1444	898	62	Pass
0.1107	1392	849	60	Pass
0.1118	1326	778	58	Pass
0.1129	1268	712	56	Pass
0.1140	1224	647	52	Pass
0.1150	1170	585	50	Pass
0.1161	1116	530	47	Pass
0.1172	1065	483	45	Pass
0.1183	1025	428	41	Pass
0.1194	993	385	38	Pass
0.1205	957	376	39	Pass
0.1216	923	372	40	Pass
0.1227	884	367	41	Pass
0.1237	820	362	44	Pass
0.1248	755	357	47	Pass
0.1259	718	355	49	Pass
0.1270	683	353	51	Pass
0.1281	646	349	54	Pass
0.1292	610	347	56	Pass
0.1303	561	345	61	Pass
0.1314	529	344	65	Pass
0.1324	486	339	69	Pass
0.1335	453	336	74	Pass
0.1346	427	332	77	Pass
0.1357	392	331	84	Pass
0.1368	367	327	89	Pass
0.1379	352	325	92	Pass
0.1390	333	319	95	Pass
0.1401	317	315	99	Pass
0.1411	299	312	104	Pass

7.3 Biocell D

WVHM2012

PROJECT REPORT

Project Name: Cell D5-1103
Site Name: English Crossing
Site Address: 17406 19th Ave NE
City : Marysville, WA
Report Date: 11/3/2023
MGS Regoin : Puget East
Data Start : 1901/10/1
Data End : 2058/09/30
DOT Data Number: 05
Version Date: 2023/01/27
Version : 4.2.19

Low Flow Threshold for POC 1 : 50 Percent of the 2 Year

High Flow Threshold for POC 1: 50 year

PREDEVELOPED LAND USE

Name : Basin D
Bypass: No

GroundWater: No

<u>Pervious Land Use</u>	<u>acre</u>
C, Forest, Flat	5.406

Pervious Total	5.406
----------------	-------

<u>Impervious Land Use</u>	<u>acre</u>
----------------------------	-------------

Impervious Total	0
------------------	---

Basin Total	5.406
-------------	-------



Element Flows To:
Surface

Interflow

Groundwater

MITIGATED LAND USE

Name : Basin D Roof
 Bypass: No

GroundWater: No

<u>Pervious Land Use</u>	<u>acre</u>
Pervious Total	0
<u>Impervious Land Use</u>	<u>acre</u>
ROOF TOPS FLAT	1.578
Impervious Total	1.578
Basin Total	1.578

Element Flows To:

Surface	Interflow	Groundwater
Gravel Trench Bed 1	Gravel Trench Bed 1	

Name : Basin D
 Bypass: No

GroundWater: No

<u>Pervious Land Use</u>	<u>acre</u>
C, Pasture, Flat	1.291
Pervious Total	1.291
<u>Impervious Land Use</u>	<u>acre</u>
ROADS FLAT	1.106
DRIVEWAYS FLAT	0.748
SIDEWALKS FLAT	0.25
Impervious Total	2.104
Basin Total	3.395

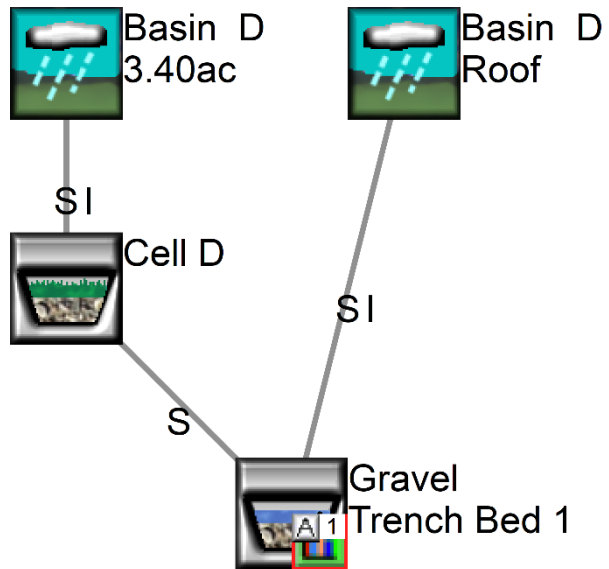

Element Flows To:

Surface	Interflow	Groundwater
Surface Cell D	Surface Cell D	

Name : Cell D
 Bottom Length: 740.00 ft.
 Bottom Width: 25.00 ft.
 Material thickness of first layer: 1.5
 Material type for first layer: SMMWW 12 in/hr

Material thickness of second layer: 0
Material type for second layer: Sand
Material thickness of third layer: 0
Material type for third layer: GRAVEL
Underdrain used
Underdrain Diameter (feet): 0.5
Orifice Diameter (in.): 1
Offset (in.): 0
Flow Through Underdrain (ac-ft.): 1158.678
Total Outflow (ac-ft.): 1175.454
Percent Through Underdrain: 98.57

Discharge Structure

Riser Height: 1 ft.
Riser Diameter: 6 in.
Notch Type: Rectangular
Notch Width: 0.050 ft.
Notch Height: 0.100 ft.
Orifice 1 Diameter: 0.2 in. **Elevation:** 0.02 ft.

Element Flows To:

Outlet 1 **Outlet 2**
 Gravel Trench Bed 1

Cell D Hydraulic Table

Stage(feet)	Area(ac.)	Volume(ac-ft.)	Discharge(cfs)	Infilt(cfs)
0.0000	0.4247	0.0000	0.0000	0.0000
0.0330	0.4247	0.0064	0.0000	0.0000
0.0659	0.4247	0.0128	0.0000	0.0000
0.0989	0.4247	0.0192	0.0000	0.0000
0.1319	0.4247	0.0256	0.0001	0.0000
0.1648	0.4247	0.0320	0.0110	0.0000
0.1978	0.4247	0.0384	0.0121	0.0000
0.2308	0.4247	0.0448	0.0130	0.0000
0.2637	0.4247	0.0512	0.0139	0.0000
0.2967	0.4247	0.0576	0.0148	0.0000
0.3297	0.4247	0.0640	0.0156	0.0000
0.3626	0.4247	0.0704	0.0163	0.0000
0.3956	0.4247	0.0768	0.0171	0.0000
0.4286	0.4247	0.0832	0.0178	0.0000
0.4615	0.4247	0.0896	0.0184	0.0000
0.4945	0.4247	0.0960	0.0191	0.0000
0.5275	0.4247	0.1024	0.0197	0.0000
0.5604	0.4247	0.1088	0.0203	0.0000
0.5934	0.4247	0.1152	0.0209	0.0000
0.6264	0.4247	0.1217	0.0215	0.0000
0.6593	0.4247	0.1281	0.0220	0.0000
0.6923	0.4247	0.1345	0.0226	0.0000
0.7253	0.4247	0.1409	0.0231	0.0000
0.7582	0.4247	0.1473	0.0236	0.0000
0.7912	0.4247	0.1537	0.0241	0.0000
0.8242	0.4247	0.1601	0.0246	0.0000
0.8571	0.4247	0.1665	0.0251	0.0000
0.8901	0.4247	0.1729	0.0256	0.0000
0.9231	0.4247	0.1793	0.0261	0.0000
0.9560	0.4247	0.1857	0.0265	0.0000

0.9890	0.4247	0.1921	0.0270	0.0000
1.0220	0.4247	0.1985	0.0274	0.0000
1.0549	0.4247	0.2049	0.0279	0.0000
1.0879	0.4247	0.2113	0.0283	0.0000
1.1209	0.4247	0.2177	0.0287	0.0000
1.1538	0.4247	0.2241	0.0291	0.0000
1.1868	0.4247	0.2305	0.0296	0.0000
1.2198	0.4247	0.2369	0.0300	0.0000
1.2527	0.4247	0.2433	0.0304	0.0000
1.2857	0.4247	0.2497	0.0308	0.0000
1.3187	0.4247	0.2561	0.0312	0.0000
1.3516	0.4247	0.2625	0.0315	0.0000
1.3846	0.4247	0.2689	0.0319	0.0000
1.4176	0.4247	0.2753	0.0323	0.0000
1.4505	0.4247	0.2817	0.0327	0.0000
1.4835	0.4247	0.2881	0.0331	0.0000
1.5000	0.4247	0.2913	0.0429	0.0000

Surface Cell D Hydraulic Table

<u>Stage(feet)</u>	<u>Area(ac.)</u>	<u>Volume(ac-ft.)</u>	<u>Discharge(cfs)</u>	<u>To Amended(cfs)</u>	<u>Wetted Surface</u>
1.5000	0.4247	0.2913	0.0000	5.1389	0.0000
1.5330	0.4282	0.3054	0.0001	5.1389	0.0000
1.5659	0.4317	0.3196	0.0002	5.3648	0.0000
1.5989	0.4351	0.3338	0.0003	5.4777	0.0000
1.6319	0.4386	0.3482	0.0004	5.5907	0.0000
1.6648	0.4421	0.3628	0.0004	5.7036	0.0000
1.6978	0.4456	0.3774	0.0005	5.8165	0.0000
1.7308	0.4491	0.3921	0.0005	5.9295	0.0000
1.7637	0.4525	0.4070	0.0005	6.0424	0.0000
1.7967	0.4560	0.4220	0.0006	6.1554	0.0000
1.8297	0.4595	0.4371	0.0006	6.2683	0.0000
1.8626	0.4630	0.4523	0.0006	6.3813	0.0000
1.8956	0.4665	0.4676	0.0007	6.4942	0.0000
1.9286	0.4700	0.4830	0.0007	6.6071	0.0000
1.9615	0.4735	0.4986	0.0007	6.7201	0.0000
1.9945	0.4770	0.5143	0.0007	6.8330	0.0000
2.0275	0.4805	0.5300	0.0008	6.9460	0.0000
2.0604	0.4840	0.5459	0.0008	7.0589	0.0000
2.0934	0.4875	0.5620	0.0008	7.1719	0.0000
2.1264	0.4910	0.5781	0.0008	7.2848	0.0000
2.1593	0.4945	0.5943	0.0009	7.3977	0.0000
2.1923	0.4980	0.6107	0.0009	7.5107	0.0000
2.2253	0.5016	0.6272	0.0009	7.6236	0.0000
2.2582	0.5051	0.6438	0.0009	7.7366	0.0000
2.2912	0.5086	0.6605	0.0010	7.8495	0.0000
2.3242	0.5121	0.6773	0.0010	7.9625	0.0000
2.3571	0.5156	0.6942	0.0010	8.0754	0.0000
2.3901	0.5191	0.7113	0.0010	8.1883	0.0000
2.4231	0.5227	0.7285	0.0016	8.3013	0.0000
2.4560	0.5262	0.7458	0.0033	8.4142	0.0000
2.4890	0.5297	0.7632	0.0055	8.5272	0.0000
2.5220	0.5333	0.7807	0.0236	8.5648	0.0000
2.5549	0.5368	0.7983	0.0742	8.5648	0.0000
2.5879	0.5403	0.8161	0.1405	8.5648	0.0000
2.6209	0.5438	0.8339	0.2127	8.5648	0.0000
2.6538	0.5474	0.8519	0.2807	8.5648	0.0000
2.6868	0.5509	0.8700	0.3358	8.5648	0.0000
2.7198	0.5545	0.8883	0.3735	8.5648	0.0000

2.7527	0.5580	0.9066	0.4023	8.5648	0.0000
2.7857	0.5615	0.9250	0.4274	8.5648	0.0000
2.8187	0.5651	0.9436	0.4510	8.5648	0.0000
2.8516	0.5686	0.9623	0.4735	8.5648	0.0000
2.8846	0.5722	0.9811	0.4949	8.5648	0.0000
2.9176	0.5757	1.0000	0.5154	8.5648	0.0000
2.9505	0.5793	1.0191	0.5351	8.5648	0.0000
2.9835	0.5828	1.0382	0.5541	8.5648	0.0000
3.0000	0.5846	1.0478	0.5725	8.5648	0.0000

Name : Surface Cell D

Element Flows To:

Outlet 1 **Outlet 2**
Gravel Trench Bed 1 Cell D

Name : Gravel Trench Bed 1

Bottom Length: 990.00 ft.

Bottom Width: 29.00 ft.

Trench bottom slope 1: 0.1 To 1

Trench Left side slope 0: 0.1 To 1

Trench right side slope 2: 0.1 To 1

Material thickness of first layer: 3

Pour Space of material for first layer: 0.48

Material thickness of second layer: 0

Pour Space of material for second layer: 0

Material thickness of third layer: 0

Pour Space of material for third layer: 0

Discharge Structure

Riser Height: 2.8 ft.

Riser Diameter: 18 in.

Notch Type: Rectangular

Notch Width: 0.060 ft.

Notch Height: 0.960 ft.

Orifice 1 Diameter: 1.3 in. **Elevation:** 0 ft.

Element Flows To:

Outlet 1 **Outlet 2**

Gravel Trench Bed Hydraulic Table

<u>Stage(feet)</u>	<u>Area(ac.)</u>	<u>Volume(ac-ft.)</u>	<u>Discharge(cfs)</u>	<u>Infilt(cfs)</u>
0.0000	0.659	0.000	0.000	0.000
0.0333	0.659	0.010	0.008	0.000
0.0667	0.659	0.021	0.011	0.000
0.1000	0.659	0.031	0.014	0.000
0.1333	0.659	0.042	0.016	0.000
0.1667	0.659	0.052	0.018	0.000
0.2000	0.660	0.063	0.020	0.000
0.2333	0.660	0.073	0.022	0.000
0.2667	0.660	0.084	0.023	0.000
0.3000	0.660	0.095	0.025	0.000

0.3333	0.660	0.105	0.026	0.000
0.3667	0.660	0.116	0.027	0.000
0.4000	0.661	0.126	0.029	0.000
0.4333	0.661	0.137	0.030	0.000
0.4667	0.661	0.147	0.031	0.000
0.5000	0.661	0.158	0.032	0.000
0.5333	0.661	0.169	0.033	0.000
0.5667	0.661	0.179	0.034	0.000
0.6000	0.661	0.190	0.035	0.000
0.6333	0.662	0.200	0.036	0.000
0.6667	0.662	0.211	0.037	0.000
0.7000	0.662	0.222	0.038	0.000
0.7333	0.662	0.232	0.039	0.000
0.7667	0.662	0.243	0.040	0.000
0.8000	0.662	0.253	0.041	0.000
0.8333	0.663	0.264	0.041	0.000
0.8667	0.663	0.275	0.042	0.000
0.9000	0.663	0.285	0.043	0.000
0.9333	0.663	0.296	0.044	0.000
0.9667	0.663	0.306	0.045	0.000
1.0000	0.663	0.317	0.045	0.000
1.0333	0.663	0.328	0.046	0.000
1.0667	0.664	0.338	0.047	0.000
1.1000	0.664	0.349	0.048	0.000
1.1333	0.664	0.360	0.048	0.000
1.1667	0.664	0.370	0.049	0.000
1.2000	0.664	0.381	0.050	0.000
1.2333	0.664	0.391	0.050	0.000
1.2667	0.665	0.402	0.051	0.000
1.3000	0.665	0.413	0.052	0.000
1.3333	0.665	0.423	0.053	0.000
1.3667	0.665	0.434	0.053	0.000
1.4000	0.665	0.445	0.054	0.000
1.4333	0.665	0.455	0.054	0.000
1.4667	0.666	0.466	0.055	0.000
1.5000	0.666	0.477	0.056	0.000
1.5333	0.666	0.487	0.056	0.000
1.5667	0.666	0.498	0.057	0.000
1.6000	0.666	0.509	0.058	0.000
1.6333	0.666	0.519	0.058	0.000
1.6667	0.666	0.530	0.059	0.000
1.7000	0.667	0.541	0.059	0.000
1.7333	0.667	0.551	0.060	0.000
1.7667	0.667	0.562	0.061	0.000
1.8000	0.667	0.573	0.061	0.000
1.8333	0.667	0.583	0.062	0.000
1.8667	0.667	0.594	0.063	0.000
1.9000	0.668	0.605	0.066	0.000
1.9333	0.668	0.615	0.069	0.000
1.9667	0.668	0.626	0.073	0.000
2.0000	0.668	0.637	0.077	0.000
2.0333	0.668	0.647	0.081	0.000
2.0667	0.668	0.658	0.086	0.000
2.1000	0.668	0.669	0.091	0.000
2.1333	0.669	0.680	0.096	0.000
2.1667	0.669	0.690	0.102	0.000
2.2000	0.669	0.701	0.108	0.000
2.2333	0.669	0.712	0.113	0.000

2.2667	0.669	0.722	0.120	0.000
2.3000	0.669	0.733	0.126	0.000
2.3333	0.670	0.744	0.132	0.000
2.3667	0.670	0.755	0.138	0.000
2.4000	0.670	0.765	0.145	0.000
2.4333	0.670	0.776	0.152	0.000
2.4667	0.670	0.787	0.158	0.000
2.5000	0.670	0.797	0.165	0.000
2.5333	0.670	0.808	0.172	0.000
2.5667	0.671	0.819	0.179	0.000
2.6000	0.671	0.830	0.186	0.000
2.6333	0.671	0.840	0.193	0.000
2.6667	0.671	0.851	0.200	0.000
2.7000	0.671	0.862	0.207	0.000
2.7333	0.671	0.873	0.214	0.000
2.7667	0.672	0.883	0.221	0.000
2.8000	0.672	0.894	0.228	0.000
2.8333	0.672	0.905	0.325	0.000
2.8667	0.672	0.916	0.503	0.000
2.9000	0.672	0.926	0.732	0.000
2.9333	0.672	0.937	1.001	0.000
2.9667	0.673	0.948	1.305	0.000
3.0000	0.673	0.959	1.635	0.000

ANALYSIS RESULTS

Stream Protection Duration

Predeveloped Landuse Totals for POC #1
Total Pervious Area:5.406
Total Impervious Area:0

Mitigated Landuse Totals for POC #1
Total Pervious Area:1.291
Total Impervious Area:3.682

Flow Frequency Return Periods for Predeveloped. POC #1

<u>Return Period</u>	<u>Flow(cfs)</u>
2 year	0.116869
5 year	0.17187
10 year	0.200647
25 year	0.22933
50 year	0.246129
100 year	0.259817

Flow Frequency Return Periods for Mitigated. POC #1

<u>Return Period</u>	<u>Flow(cfs)</u>
2 year	0.063414
5 year	0.114115
10 year	0.166576
25 year	0.263959

50 year 0.367038
100 year 0.504803

Stream Protection Duration

POC #1

The Facility PASSED

The Facility PASSED.

Flow(cfs)	Predev	Mit	Percentage	Pass/Fail
0.0584	55436	50387	90	Pass
0.0603	51120	34263	67	Pass
0.0622	47316	23176	48	Pass
0.0641	43814	19752	45	Pass
0.0660	40589	17748	43	Pass
0.0679	37742	16201	42	Pass
0.0698	35216	14891	42	Pass
0.0717	32788	13862	42	Pass
0.0736	30542	12926	42	Pass
0.0755	28522	12232	42	Pass
0.0774	26622	11517	43	Pass
0.0793	24943	10905	43	Pass
0.0812	23319	10311	44	Pass
0.0831	21844	9782	44	Pass
0.0850	20501	9326	45	Pass
0.0869	19207	8891	46	Pass
0.0888	17979	8516	47	Pass
0.0907	16873	8114	48	Pass
0.0926	15816	7724	48	Pass
0.0945	14853	7360	49	Pass
0.0964	13939	7074	50	Pass
0.0982	13074	6733	51	Pass
0.1001	12331	6468	52	Pass
0.1020	11621	6166	53	Pass
0.1039	10994	5874	53	Pass
0.1058	10371	5632	54	Pass
0.1077	9810	5427	55	Pass
0.1096	9215	5224	56	Pass
0.1115	8736	5054	57	Pass
0.1134	8252	4881	59	Pass
0.1153	7812	4726	60	Pass
0.1172	7360	4583	62	Pass
0.1191	6991	4428	63	Pass
0.1210	6650	4291	64	Pass
0.1229	6342	4156	65	Pass
0.1248	6078	4049	66	Pass
0.1267	5813	3937	67	Pass
0.1286	5566	3827	68	Pass
0.1305	5320	3721	69	Pass
0.1324	5094	3606	70	Pass
0.1343	4873	3494	71	Pass
0.1362	4669	3392	72	Pass
0.1381	4430	3298	74	Pass
0.1400	4204	3207	76	Pass
0.1419	4018	3102	77	Pass
0.1438	3849	3008	78	Pass
0.1456	3691	2924	79	Pass

0.1475	3532	2836	80	Pass
0.1494	3392	2746	80	Pass
0.1513	3270	2667	81	Pass
0.1532	3150	2584	82	Pass
0.1551	3050	2516	82	Pass
0.1570	2961	2446	82	Pass
0.1589	2879	2387	82	Pass
0.1608	2794	2307	82	Pass
0.1627	2716	2234	82	Pass
0.1646	2635	2161	82	Pass
0.1665	2502	2085	83	Pass
0.1684	2422	2025	83	Pass
0.1703	2321	1955	84	Pass
0.1722	2206	1875	84	Pass
0.1741	2104	1801	85	Pass
0.1760	2002	1712	85	Pass
0.1779	1911	1647	86	Pass
0.1798	1835	1570	85	Pass
0.1817	1764	1489	84	Pass
0.1836	1701	1430	84	Pass
0.1855	1633	1358	83	Pass
0.1874	1571	1298	82	Pass
0.1893	1503	1242	82	Pass
0.1911	1445	1194	82	Pass
0.1930	1389	1155	83	Pass
0.1949	1321	1111	84	Pass
0.1968	1266	1067	84	Pass
0.1987	1223	1011	82	Pass
0.2006	1168	968	82	Pass
0.2025	1115	931	83	Pass
0.2044	1065	886	83	Pass
0.2063	1025	824	80	Pass
0.2082	992	759	76	Pass
0.2101	954	717	75	Pass
0.2120	922	678	73	Pass
0.2139	884	645	72	Pass
0.2158	820	606	73	Pass
0.2177	756	576	76	Pass
0.2196	719	548	76	Pass
0.2215	688	516	75	Pass
0.2234	645	478	74	Pass
0.2253	608	424	69	Pass
0.2272	561	380	67	Pass
0.2291	527	359	68	Pass
0.2310	485	356	73	Pass
0.2329	454	351	77	Pass
0.2348	427	348	81	Pass
0.2366	394	343	87	Pass
0.2385	367	340	92	Pass
0.2404	351	337	96	Pass
0.2423	333	335	100	Pass
0.2442	317	332	104	Pass
0.2461	299	327	109	Pass

7.4 Biocell E

WWHM2012

PROJECT REPORT

Project Name: Cell E5 1108
Site Name: English Crossing
Site Address: 17406 19th Ave NE
City :
Report Date: 11/8/2023
MGS Regoin : Puget East
Data Start : 1901/10/1
Data End : 2058/09/30
DOT Data Number: 05
Version Date: 2023/01/27
Version : 4.2.19

Low Flow Threshold for POC 1 : 50 Percent of the 2 Year

High Flow Threshold for POC 1: 50 year

PREDEVELOPED LAND USE

Name : Basin 1
Bypass: No

GroundWater: No

<u>Pervious Land Use</u>	<u>acre</u>
C, Forest, Flat	2.633

Pervious Total	2.633
----------------	-------

<u>Impervious Land Use</u>	<u>acre</u>
----------------------------	-------------

Impervious Total	0
------------------	---

Basin Total	2.633
-------------	-------



Basin 1
2.63ac

Element Flows To:

Surface	Interflow	Groundwater
---------	-----------	-------------

MITIGATED LAND USE

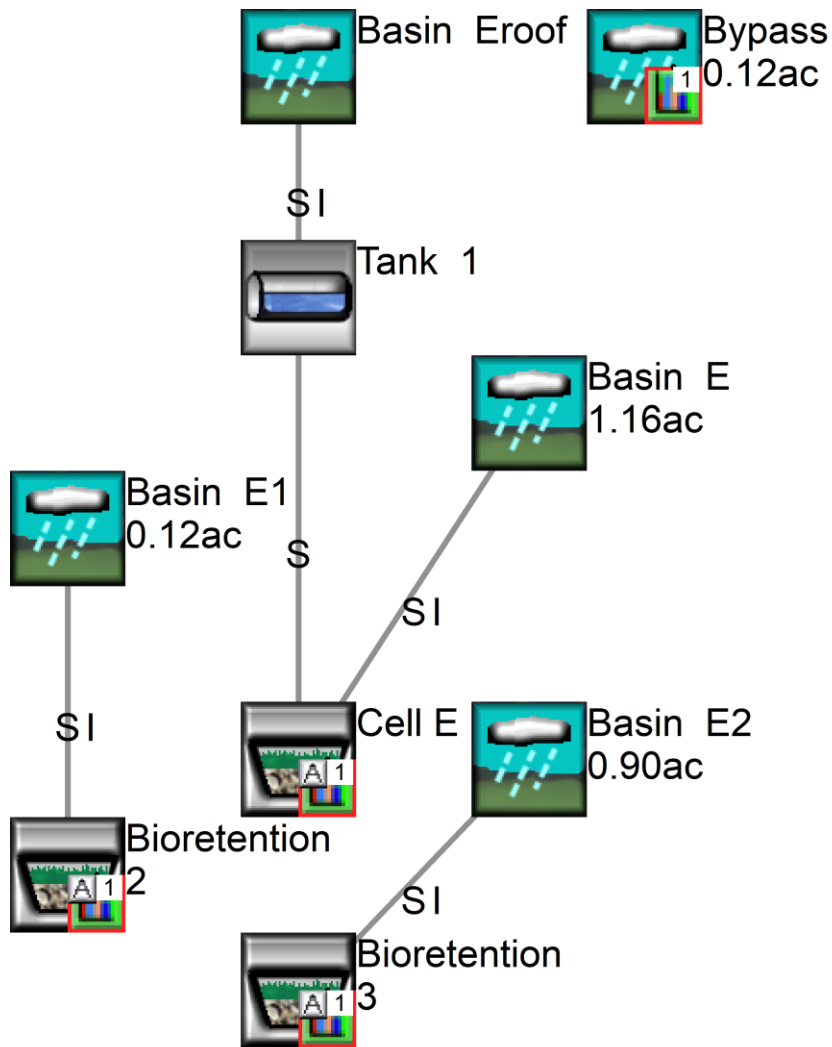

Name : Basin E
Bypass: No

GroundWater: No

<u>Pervious Land Use</u>	<u>acre</u>
C, Pasture, Flat	.786
Pervious Total	0.786
<u>Impervious Land Use</u>	<u>acre</u>
ROADS FLAT	0.299
SIDEWALKS FLAT	0.073
Impervious Total	0.372
Basin Total	1.158

Element Flows To:

Surface
Surface Cell E

Interflow
Surface Cell E

Groundwater

Name : Cell E
Bottom Length: 120.00 ft.
Bottom Width: 46.00 ft.
Material thickness of first layer: 1.5
Material type for first layer: SMMWW 12 in/hr
Material thickness of second layer: 0
Material type for second layer: Sand
Material thickness of third layer: 0
Material type for third layer: GRAVEL
Underdrain used
Underdrain Diameter (feet): 0.5
Orifice Diameter (in.): 0.5
Offset (in.): 0
Flow Through Underdrain (ac-ft.): 345.186
Total Outflow (ac-ft.): 350.926
Percent Through Underdrain: 98.36
Discharge Structure
Riser Height: 1.5 ft.
Riser Diameter: 1.9 in.
Orifice 1 Diameter: 0.1 in. **Elevation:** 0.02 ft.

Element Flows To:

Outlet 1 **Outlet 2**

Cell E Hydraulic Table

<u>Stage(feet)</u>	<u>Area(ac.)</u>	<u>Volume(ac-ft.)</u>	<u>Discharge(cfs)</u>	<u>Infilt(cfs)</u>
0.0000	0.1267	0.0000	0.0000	0.0000
0.0385	0.1267	0.0022	0.0000	0.0000
0.0769	0.1267	0.0045	0.0000	0.0000
0.1154	0.1267	0.0067	0.0000	0.0000
0.1538	0.1267	0.0089	0.0012	0.0000
0.1923	0.1267	0.0111	0.0030	0.0000
0.2308	0.1267	0.0134	0.0033	0.0000
0.2692	0.1267	0.0156	0.0035	0.0000
0.3077	0.1267	0.0178	0.0038	0.0000
0.3462	0.1267	0.0201	0.0040	0.0000
0.3846	0.1267	0.0223	0.0042	0.0000
0.4231	0.1267	0.0245	0.0044	0.0000
0.4615	0.1267	0.0267	0.0046	0.0000
0.5000	0.1267	0.0290	0.0048	0.0000
0.5385	0.1267	0.0312	0.0050	0.0000
0.5769	0.1267	0.0334	0.0052	0.0000
0.6154	0.1267	0.0357	0.0053	0.0000
0.6538	0.1267	0.0379	0.0055	0.0000
0.6923	0.1267	0.0401	0.0056	0.0000
0.7308	0.1267	0.0423	0.0058	0.0000
0.7692	0.1267	0.0446	0.0060	0.0000
0.8077	0.1267	0.0468	0.0061	0.0000
0.8462	0.1267	0.0490	0.0062	0.0000

0.8846	0.1267	0.0513	0.0064	0.0000
0.9231	0.1267	0.0535	0.0065	0.0000
0.9615	0.1267	0.0557	0.0067	0.0000
1.0000	0.1267	0.0579	0.0068	0.0000
1.0385	0.1267	0.0602	0.0069	0.0000
1.0769	0.1267	0.0624	0.0070	0.0000
1.1154	0.1267	0.0646	0.0072	0.0000
1.1538	0.1267	0.0669	0.0073	0.0000
1.1923	0.1267	0.0691	0.0074	0.0000
1.2308	0.1267	0.0713	0.0075	0.0000
1.2692	0.1267	0.0736	0.0076	0.0000
1.3077	0.1267	0.0758	0.0078	0.0000
1.3462	0.1267	0.0780	0.0079	0.0000
1.3846	0.1267	0.0802	0.0080	0.0000
1.4231	0.1267	0.0825	0.0081	0.0000
1.4615	0.1267	0.0847	0.0082	0.0000
1.5000	0.1267	0.0869	0.0118	0.0000

Surface Cell E Hydraulic Table

<u>Stage(feet)</u>	<u>Area(ac.)</u>	<u>Volume(ac-ft.)</u>	<u>Discharge(cfs)</u>	<u>To Amended(cfs)</u>	<u>Wetted Surface</u>
1.5000	0.1267	0.0869	0.0000	1.5333	0.0000
1.5385	0.1276	0.0918	0.0000	1.5333	0.0000
1.5769	0.1285	0.0967	0.0001	1.6120	0.0000
1.6154	0.1294	0.1017	0.0001	1.6513	0.0000
1.6538	0.1303	0.1067	0.0001	1.6906	0.0000
1.6923	0.1311	0.1117	0.0001	1.7299	0.0000
1.7308	0.1320	0.1168	0.0001	1.7692	0.0000
1.7692	0.1329	0.1219	0.0001	1.8085	0.0000
1.8077	0.1338	0.1270	0.0001	1.8479	0.0000
1.8462	0.1347	0.1322	0.0002	1.8872	0.0000
1.8846	0.1356	0.1374	0.0002	1.9265	0.0000
1.9231	0.1365	0.1426	0.0002	1.9658	0.0000
1.9615	0.1375	0.1479	0.0002	2.0051	0.0000
2.0000	0.1384	0.1532	0.0002	2.0444	0.0000
2.0385	0.1393	0.1585	0.0002	2.0838	0.0000
2.0769	0.1402	0.1639	0.0002	2.1231	0.0000
2.1154	0.1411	0.1693	0.0002	2.1624	0.0000
2.1538	0.1420	0.1747	0.0002	2.2017	0.0000
2.1923	0.1429	0.1802	0.0002	2.2410	0.0000
2.2308	0.1439	0.1857	0.0002	2.2803	0.0000
2.2692	0.1448	0.1913	0.0002	2.3197	0.0000
2.3077	0.1457	0.1969	0.0002	2.3590	0.0000
2.3462	0.1467	0.2025	0.0002	2.3983	0.0000
2.3846	0.1476	0.2082	0.0003	2.4376	0.0000
2.4231	0.1485	0.2139	0.0003	2.4769	0.0000
2.4615	0.1495	0.2196	0.0003	2.5162	0.0000
2.5000	0.1504	0.2254	0.0003	2.5556	0.0000
2.5385	0.1514	0.2312	0.0003	2.5949	0.0000
2.5769	0.1523	0.2370	0.0003	2.6342	0.0000
2.6154	0.1533	0.2429	0.0003	2.6735	0.0000
2.6538	0.1542	0.2488	0.0003	2.7128	0.0000
2.6923	0.1552	0.2547	0.0003	2.7521	0.0000
2.7308	0.1561	0.2607	0.0003	2.7915	0.0000
2.7692	0.1571	0.2667	0.0003	2.8308	0.0000
2.8077	0.1580	0.2728	0.0003	2.8701	0.0000
2.8462	0.1590	0.2789	0.0003	2.9094	0.0000
2.8846	0.1600	0.2850	0.0003	2.9487	0.0000
2.9231	0.1609	0.2912	0.0003	2.9880	0.0000

2.9615	0.1619	0.2974	0.0003	3.0274	0.0000
3.0000	0.1629	0.3037	0.0003	3.0667	0.0000
3.0385	0.1639	0.3099	0.0120	3.0667	0.0000
3.0769	0.1648	0.3163	0.0221	3.0667	0.0000
3.1154	0.1658	0.3226	0.0272	3.0667	0.0000
3.1538	0.1668	0.3290	0.0313	3.0667	0.0000
3.1923	0.1678	0.3355	0.0350	3.0667	0.0000
3.2308	0.1688	0.3419	0.0383	3.0667	0.0000
3.2692	0.1698	0.3484	0.0413	3.0667	0.0000
3.3077	0.1708	0.3550	0.0442	3.0667	0.0000
3.3462	0.1718	0.3616	0.0468	3.0667	0.0000
3.3846	0.1727	0.3682	0.0493	3.0667	0.0000
3.4231	0.1737	0.3749	0.0517	3.0667	0.0000
3.4615	0.1748	0.3816	0.0540	3.0667	0.0000
3.5000	0.1758	0.3883	0.0562	3.0667	0.0000
3.5000	0.1758	0.3883	0.0583	3.0667	0.0000

Name : Surface Cell E

Element Flows To:

Outlet 1 **Outlet 2**
Cell E

Name : Basin Eroof

Bypass: No

GroundWater: No

<u>Pervious Land Use</u>	<u>acre</u>
Pervious Total	0
<u>Impervious Land Use</u>	<u>acre</u>
ROOF TOPS FLAT	0.153
Impervious Total	0.153
Basin Total	0.153

Element Flows To:

Surface **Interflow** **Groundwater**
Tank 1 Tank 1

Name : Tank 1

Tank Name: Tank 1

Dimensions

Depth: 3 ft.
Tank Type : Circular
Diameter : 3 ft.

Length : 120 ft.
Discharge Structure
 Riser Height: 2.5 ft.
 Riser Diameter: 4 in.
 Orifice 1 Diameter: 0.3 in. Elevation: 0 ft.

Element Flows To:
 Outlet 1 Outlet 2
 Surface Cell E

Tank Hydraulic Table

<u>Stage(feet)</u>	<u>Area(ac.)</u>	<u>Volume(ac-ft.)</u>	<u>Discharge(cfs)</u>	<u>Infilt(cfs)</u>
0.0000	0.000	0.000	0.000	0.000
0.0333	0.001	0.000	0.000	0.000
0.0667	0.002	0.000	0.000	0.000
0.1000	0.003	0.000	0.000	0.000
0.1333	0.003	0.000	0.000	0.000
0.1667	0.003	0.000	0.001	0.000
0.2000	0.004	0.000	0.001	0.000
0.2333	0.004	0.000	0.001	0.000
0.2667	0.004	0.000	0.001	0.000
0.3000	0.005	0.001	0.001	0.000
0.3333	0.005	0.001	0.001	0.000
0.3667	0.005	0.001	0.001	0.000
0.4000	0.005	0.001	0.001	0.000
0.4333	0.005	0.001	0.001	0.000
0.4667	0.006	0.001	0.001	0.000
0.5000	0.006	0.002	0.001	0.000
0.5333	0.006	0.002	0.001	0.000
0.5667	0.006	0.002	0.001	0.000
0.6000	0.006	0.002	0.001	0.000
0.6333	0.006	0.003	0.001	0.000
0.6667	0.006	0.003	0.002	0.000
0.7000	0.007	0.003	0.002	0.000
0.7333	0.007	0.003	0.002	0.000
0.7667	0.007	0.003	0.002	0.000
0.8000	0.007	0.004	0.002	0.000
0.8333	0.007	0.004	0.002	0.000
0.8667	0.007	0.004	0.002	0.000
0.9000	0.007	0.004	0.002	0.000
0.9333	0.007	0.005	0.002	0.000
0.9667	0.007	0.005	0.002	0.000
1.0000	0.007	0.005	0.002	0.000
1.0333	0.007	0.005	0.002	0.000
1.0667	0.007	0.006	0.002	0.000
1.1000	0.008	0.006	0.002	0.000
1.1333	0.008	0.006	0.002	0.000
1.1667	0.008	0.007	0.002	0.000
1.2000	0.008	0.007	0.002	0.000
1.2333	0.008	0.007	0.002	0.000
1.2667	0.008	0.007	0.002	0.000
1.3000	0.008	0.008	0.002	0.000
1.3333	0.008	0.008	0.002	0.000
1.3667	0.008	0.008	0.002	0.000
1.4000	0.008	0.008	0.002	0.000

1.4333	0.008	0.009	0.002	0.000
1.4667	0.008	0.009	0.003	0.000
1.5000	0.008	0.009	0.003	0.000
1.5333	0.008	0.010	0.003	0.000
1.5667	0.008	0.010	0.003	0.000
1.6000	0.008	0.010	0.003	0.000
1.6333	0.008	0.010	0.003	0.000
1.6667	0.008	0.011	0.003	0.000
1.7000	0.008	0.011	0.003	0.000
1.7333	0.008	0.011	0.003	0.000
1.7667	0.008	0.011	0.003	0.000
1.8000	0.008	0.012	0.003	0.000
1.8333	0.008	0.012	0.003	0.000
1.8667	0.008	0.012	0.003	0.000
1.9000	0.008	0.013	0.003	0.000
1.9333	0.007	0.013	0.003	0.000
1.9667	0.007	0.013	0.003	0.000
2.0000	0.007	0.013	0.003	0.000
2.0333	0.007	0.014	0.003	0.000
2.0667	0.007	0.014	0.003	0.000
2.1000	0.007	0.014	0.003	0.000
2.1333	0.007	0.014	0.003	0.000
2.1667	0.007	0.015	0.003	0.000
2.2000	0.007	0.015	0.003	0.000
2.2333	0.007	0.015	0.003	0.000
2.2667	0.007	0.015	0.003	0.000
2.3000	0.007	0.016	0.003	0.000
2.3333	0.006	0.016	0.003	0.000
2.3667	0.006	0.016	0.003	0.000
2.4000	0.006	0.016	0.003	0.000
2.4333	0.006	0.016	0.003	0.000
2.4667	0.006	0.017	0.003	0.000
2.5000	0.006	0.017	0.003	0.000
2.5333	0.006	0.017	0.025	0.000
2.5667	0.005	0.017	0.062	0.000
2.6000	0.005	0.017	0.100	0.000
2.6333	0.005	0.018	0.129	0.000
2.6667	0.005	0.018	0.146	0.000
2.7000	0.005	0.018	0.160	0.000
2.7333	0.004	0.018	0.173	0.000
2.7667	0.004	0.018	0.184	0.000
2.8000	0.004	0.018	0.195	0.000
2.8333	0.003	0.019	0.206	0.000
2.8667	0.003	0.019	0.216	0.000
2.9000	0.003	0.019	0.225	0.000
2.9333	0.002	0.019	0.234	0.000
2.9667	0.001	0.019	0.243	0.000
3.0000	0.000	0.019	0.251	0.000
3.0333	0.000	0.000	0.259	0.000

Name : Basin E1

Bypass: No

GroundWater: No

Pervious Land Use
C, Pasture, Flat

acre
.061

Pervious Total	0.061
<u>Impervious Land Use</u>	<u>acre</u>
ROADS FLAT	0.052
SIDEWALKS FLAT	0.009
Impervious Total	0.061
Basin Total	0.122

Element Flows To:		
Surface	Interflow	Groundwater
Surface retention 2	Surface retention 2	

Name : Basin E2
 Bypass: No

GroundWater: No

<u>Pervious Land Use</u>	<u>acre</u>
C, Pasture, Flat	.398
Pervious Total	0.398
<u>Impervious Land Use</u>	<u>acre</u>
ROADS FLAT	0.331
ROOF TOPS FLAT	0.074
SIDEWALKS FLAT	0.093
Impervious Total	0.498
Basin Total	0.896

Element Flows To:		
Surface	Interflow	Groundwater
Surface retention 3	Surface retention 3	

Name : Bypass
 Bypass: Yes

GroundWater: No

<u>Pervious Land Use</u>	<u>acre</u>
C, Pasture, Flat	.07
Pervious Total	0.07

<u>Impervious Land Use</u>	<u>acre</u>
ROOF TOPS FLAT	0.049
Impervious Total	0.049
Basin Total	0.119

Element Flows To:

Surface	Interflow	Groundwater
---------	-----------	-------------

Name : Bioretention 2
 Bottom Length: 38.00 ft.
 Bottom Width: 20.00 ft.
 Material thickness of first layer: 1.5
 Material type for first layer: SMMWW 12 in/hr
 Material thickness of second layer: 0
 Material type for second layer: Sand
 Material thickness of third layer: 0
 Material type for third layer: GRAVEL
Underdrain used
 Underdrain Diameter (feet): 0.5
 Orifice Diameter (in.): 0.3
 Offset (in.): 0.8
 Flow Through Underdrain (ac-ft.): 37.518
 Total Outflow (ac-ft.): 37.787
 Percent Through Underdrain: 99.29
Discharge Structure
 Riser Height: 1 ft.
 Riser Diameter: 1.9 in.
 Orifice 1 Diameter: 0.2 in. Elevation: 0 ft.

Element Flows To:

Outlet 1	Outlet 2
----------	----------

Bioretention 2 Hydraulic Table

Stage(feet)	Area(ac.)	Volume(ac-ft.)	Discharge(cfs)	Infilt(cfs)
0.0000	0.0174	0.0000	0.0000	0.0000
0.0330	0.0174	0.0003	0.0000	0.0000
0.0659	0.0174	0.0005	0.0000	0.0000
0.0989	0.0174	0.0008	0.0000	0.0000
0.1319	0.0174	0.0011	0.0000	0.0000
0.1648	0.0174	0.0013	0.0008	0.0000
0.1978	0.0174	0.0016	0.0009	0.0000
0.2308	0.0174	0.0018	0.0010	0.0000
0.2637	0.0174	0.0021	0.0011	0.0000
0.2967	0.0174	0.0024	0.0012	0.0000
0.3297	0.0174	0.0026	0.0013	0.0000
0.3626	0.0174	0.0029	0.0013	0.0000

0.3956	0.0174	0.0032	0.0014	0.0000
0.4286	0.0174	0.0034	0.0015	0.0000
0.4615	0.0174	0.0037	0.0015	0.0000
0.4945	0.0174	0.0039	0.0016	0.0000
0.5275	0.0174	0.0042	0.0017	0.0000
0.5604	0.0174	0.0045	0.0017	0.0000
0.5934	0.0174	0.0047	0.0018	0.0000
0.6264	0.0174	0.0050	0.0018	0.0000
0.6593	0.0174	0.0053	0.0019	0.0000
0.6923	0.0174	0.0055	0.0019	0.0000
0.7253	0.0174	0.0058	0.0020	0.0000
0.7582	0.0174	0.0060	0.0020	0.0000
0.7912	0.0174	0.0063	0.0021	0.0000
0.8242	0.0174	0.0066	0.0021	0.0000
0.8571	0.0174	0.0068	0.0022	0.0000
0.8901	0.0174	0.0071	0.0022	0.0000
0.9231	0.0174	0.0074	0.0023	0.0000
0.9560	0.0174	0.0076	0.0023	0.0000
0.9890	0.0174	0.0079	0.0023	0.0000
1.0220	0.0174	0.0082	0.0024	0.0000
1.0549	0.0174	0.0084	0.0024	0.0000
1.0879	0.0174	0.0087	0.0025	0.0000
1.1209	0.0174	0.0089	0.0025	0.0000
1.1538	0.0174	0.0092	0.0025	0.0000
1.1868	0.0174	0.0095	0.0026	0.0000
1.2198	0.0174	0.0097	0.0026	0.0000
1.2527	0.0174	0.0100	0.0027	0.0000
1.2857	0.0174	0.0103	0.0027	0.0000
1.3187	0.0174	0.0105	0.0027	0.0000
1.3516	0.0174	0.0108	0.0028	0.0000
1.3846	0.0174	0.0110	0.0028	0.0000
1.4176	0.0174	0.0113	0.0028	0.0000
1.4505	0.0174	0.0116	0.0029	0.0000
1.4835	0.0174	0.0118	0.0029	0.0000
1.5000	0.0174	0.0120	0.0029	0.0000

Surface retention 2 Hydraulic Table

<u>Stage(feet)</u>	<u>Area(ac.)</u>	<u>Volume(ac-ft.)</u>	<u>Discharge(cfs)</u>	<u>To Amended(cfs)</u>	<u>Wetted Surface</u>
1.5000	0.0174	0.0120	0.0000	0.2111	0.0000
1.5330	0.0177	0.0125	0.0002	0.2111	0.0000
1.5659	0.0180	0.0131	0.0003	0.2204	0.0000
1.5989	0.0182	0.0137	0.0003	0.2250	0.0000
1.6319	0.0185	0.0143	0.0004	0.2297	0.0000
1.6648	0.0188	0.0150	0.0004	0.2343	0.0000
1.6978	0.0191	0.0156	0.0005	0.2390	0.0000
1.7308	0.0193	0.0162	0.0005	0.2436	0.0000
1.7637	0.0196	0.0169	0.0006	0.2482	0.0000
1.7967	0.0199	0.0175	0.0006	0.2529	0.0000
1.8297	0.0202	0.0182	0.0006	0.2575	0.0000
1.8626	0.0205	0.0188	0.0007	0.2621	0.0000
1.8956	0.0207	0.0195	0.0007	0.2668	0.0000
1.9286	0.0210	0.0202	0.0007	0.2714	0.0000
1.9615	0.0213	0.0209	0.0007	0.2761	0.0000
1.9945	0.0216	0.0216	0.0008	0.2807	0.0000
2.0275	0.0219	0.0223	0.0008	0.2853	0.0000
2.0604	0.0222	0.0230	0.0008	0.2900	0.0000
2.0934	0.0225	0.0238	0.0008	0.2946	0.0000
2.1264	0.0228	0.0245	0.0009	0.2993	0.0000

2.1593	0.0231	0.0253	0.0009	0.3039	0.0000
2.1923	0.0234	0.0261	0.0009	0.3085	0.0000
2.2253	0.0237	0.0268	0.0009	0.3132	0.0000
2.2582	0.0240	0.0276	0.0009	0.3178	0.0000
2.2912	0.0243	0.0284	0.0010	0.3225	0.0000
2.3242	0.0246	0.0292	0.0010	0.3271	0.0000
2.3571	0.0249	0.0300	0.0010	0.3317	0.0000
2.3901	0.0252	0.0309	0.0010	0.3364	0.0000
2.4231	0.0255	0.0317	0.0010	0.3410	0.0000
2.4560	0.0258	0.0325	0.0011	0.3457	0.0000
2.4890	0.0262	0.0334	0.0011	0.3503	0.0000
2.5220	0.0265	0.0343	0.0065	0.3519	0.0000
2.5549	0.0268	0.0351	0.0186	0.3519	0.0000
2.5879	0.0271	0.0360	0.0245	0.3519	0.0000
2.6209	0.0274	0.0369	0.0286	0.3519	0.0000
2.6538	0.0278	0.0378	0.0321	0.3519	0.0000
2.6868	0.0281	0.0388	0.0353	0.3519	0.0000
2.7198	0.0284	0.0397	0.0382	0.3519	0.0000
2.7527	0.0288	0.0406	0.0409	0.3519	0.0000
2.7857	0.0291	0.0416	0.0434	0.3519	0.0000
2.8187	0.0294	0.0426	0.0458	0.3519	0.0000
2.8516	0.0298	0.0435	0.0481	0.3519	0.0000
2.8846	0.0301	0.0445	0.0502	0.3519	0.0000
2.9176	0.0304	0.0455	0.0523	0.3519	0.0000
2.9505	0.0308	0.0465	0.0543	0.3519	0.0000
2.9835	0.0311	0.0475	0.0562	0.3519	0.0000
3.0000	0.0313	0.0481	0.0581	0.3519	0.0000

Name : Surface retention 2

Element Flows To:

Outlet 1 **Outlet 2**
Bioretention 2

Name : Bioretention 3

Bottom Length: 92.00 ft.

Bottom Width: 45.00 ft.

Material thickness of first layer: 1.5

Material type for first layer: SMMWW 12 in/hr

Material thickness of second layer: 0

Material type for second layer: Sand

Material thickness of third layer: 0

Material type for third layer: GRAVEL

Underdrain used

Underdrain Diameter (feet): 0.5

Orifice Diameter (in.): 0.5

Offset (in.): 0.2

Flow Through Underdrain (ac-ft.): 265.836

Total Outflow (ac-ft.): 285.712

Percent Through Underdrain: 93.04

Discharge Structure

Riser Height: 1 ft.

Riser Diameter: 1.5 in.

Notch Type: Rectangular

Notch Width: 0.125 ft.

Notch Height: 0.100 ft.

Orifice 1 Diameter: 0.5 in. Elevation: 0.02 ft.

Element Flows To:

Outlet 1

Outlet 2

Bioretention 3 Hydraulic Table

<u>Stage(feet)</u>	<u>Area(ac.)</u>	<u>Volume(ac-ft.)</u>	<u>Discharge(cfs)</u>	<u>Infilt(cfs)</u>
0.0000	0.0950	0.0000	0.0000	0.0000
0.0330	0.0950	0.0014	0.0000	0.0000
0.0659	0.0950	0.0029	0.0000	0.0000
0.0989	0.0950	0.0043	0.0000	0.0000
0.1319	0.0950	0.0057	0.0000	0.0000
0.1648	0.0950	0.0072	0.0026	0.0000
0.1978	0.0950	0.0086	0.0029	0.0000
0.2308	0.0950	0.0100	0.0031	0.0000
0.2637	0.0950	0.0115	0.0034	0.0000
0.2967	0.0950	0.0129	0.0036	0.0000
0.3297	0.0950	0.0143	0.0038	0.0000
0.3626	0.0950	0.0158	0.0040	0.0000
0.3956	0.0950	0.0172	0.0042	0.0000
0.4286	0.0950	0.0186	0.0044	0.0000
0.4615	0.0950	0.0201	0.0045	0.0000
0.4945	0.0950	0.0215	0.0047	0.0000
0.5275	0.0950	0.0229	0.0048	0.0000
0.5604	0.0950	0.0244	0.0050	0.0000
0.5934	0.0950	0.0258	0.0052	0.0000
0.6264	0.0950	0.0272	0.0053	0.0000
0.6593	0.0950	0.0287	0.0054	0.0000
0.6923	0.0950	0.0301	0.0056	0.0000
0.7253	0.0950	0.0315	0.0057	0.0000
0.7582	0.0950	0.0330	0.0058	0.0000
0.7912	0.0950	0.0344	0.0060	0.0000
0.8242	0.0950	0.0358	0.0061	0.0000
0.8571	0.0950	0.0373	0.0062	0.0000
0.8901	0.0950	0.0387	0.0063	0.0000
0.9231	0.0950	0.0401	0.0065	0.0000
0.9560	0.0950	0.0416	0.0066	0.0000
0.9890	0.0950	0.0430	0.0067	0.0000
1.0220	0.0950	0.0444	0.0068	0.0000
1.0549	0.0950	0.0459	0.0069	0.0000
1.0879	0.0950	0.0473	0.0070	0.0000
1.1209	0.0950	0.0487	0.0071	0.0000
1.1538	0.0950	0.0501	0.0072	0.0000
1.1868	0.0950	0.0516	0.0073	0.0000
1.2198	0.0950	0.0530	0.0074	0.0000
1.2527	0.0950	0.0544	0.0075	0.0000
1.2857	0.0950	0.0559	0.0076	0.0000
1.3187	0.0950	0.0573	0.0077	0.0000
1.3516	0.0950	0.0587	0.0078	0.0000
1.3846	0.0950	0.0602	0.0079	0.0000
1.4176	0.0950	0.0616	0.0080	0.0000
1.4505	0.0950	0.0630	0.0081	0.0000
1.4835	0.0950	0.0645	0.0082	0.0000

1.5000 0.0950 0.0652 0.0083 0.0000

Surface retention 3 Hydraulic Table

<u>Stage(feet)</u>	<u>Area(ac.)</u>	<u>Volume(ac-ft.)</u>	<u>Discharge(cfs)</u>	<u>To Amended(cfs)</u>	<u>Wetted Surface</u>
1.5000	0.0950	0.0652	0.0000	1.1500	0.0000
1.5330	0.0957	0.0683	0.0008	1.1500	0.0000
1.5659	0.0963	0.0715	0.0015	1.2006	0.0000
1.5989	0.0969	0.0747	0.0019	1.2258	0.0000
1.6319	0.0975	0.0779	0.0023	1.2511	0.0000
1.6648	0.0982	0.0811	0.0026	1.2764	0.0000
1.6978	0.0988	0.0844	0.0029	1.3016	0.0000
1.7308	0.0994	0.0876	0.0031	1.3269	0.0000
1.7637	0.1001	0.0909	0.0033	1.3522	0.0000
1.7967	0.1007	0.0942	0.0036	1.3775	0.0000
1.8297	0.1014	0.0976	0.0038	1.4027	0.0000
1.8626	0.1020	0.1009	0.0040	1.4280	0.0000
1.8956	0.1026	0.1043	0.0042	1.4533	0.0000
1.9286	0.1033	0.1077	0.0043	1.4786	0.0000
1.9615	0.1039	0.1111	0.0045	1.5038	0.0000
1.9945	0.1046	0.1145	0.0047	1.5291	0.0000
2.0275	0.1052	0.1180	0.0048	1.5544	0.0000
2.0604	0.1059	0.1215	0.0050	1.5797	0.0000
2.0934	0.1065	0.1250	0.0051	1.6049	0.0000
2.1264	0.1072	0.1285	0.0053	1.6302	0.0000
2.1593	0.1078	0.1320	0.0054	1.6555	0.0000
2.1923	0.1085	0.1356	0.0056	1.6808	0.0000
2.2253	0.1092	0.1392	0.0057	1.7060	0.0000
2.2582	0.1098	0.1428	0.0058	1.7313	0.0000
2.2912	0.1105	0.1464	0.0060	1.7566	0.0000
2.3242	0.1112	0.1501	0.0061	1.7819	0.0000
2.3571	0.1118	0.1538	0.0062	1.8071	0.0000
2.3901	0.1125	0.1575	0.0063	1.8324	0.0000
2.4231	0.1132	0.1612	0.0079	1.8577	0.0000
2.4560	0.1138	0.1649	0.0121	1.8830	0.0000
2.4890	0.1145	0.1687	0.0177	1.9082	0.0000
2.5220	0.1152	0.1725	0.0241	1.9167	0.0000
2.5549	0.1159	0.1763	0.0315	1.9167	0.0000
2.5879	0.1165	0.1801	0.0348	1.9167	0.0000
2.6209	0.1172	0.1840	0.0374	1.9167	0.0000
2.6538	0.1179	0.1878	0.0397	1.9167	0.0000
2.6868	0.1186	0.1917	0.0418	1.9167	0.0000
2.7198	0.1193	0.1957	0.0437	1.9167	0.0000
2.7527	0.1200	0.1996	0.0454	1.9167	0.0000
2.7857	0.1207	0.2036	0.0471	1.9167	0.0000
2.8187	0.1214	0.2076	0.0487	1.9167	0.0000
2.8516	0.1221	0.2116	0.0502	1.9167	0.0000
2.8846	0.1228	0.2156	0.0516	1.9167	0.0000
2.9176	0.1235	0.2197	0.0530	1.9167	0.0000
2.9505	0.1242	0.2237	0.0543	1.9167	0.0000
2.9835	0.1249	0.2279	0.0556	1.9167	0.0000
3.0000	0.1252	0.2299	0.0568	1.9167	0.0000

Name : Surface retention 3

Element Flows To:

Outlet 1 **Outlet 2**
 Bioretention 3

ANALYSIS RESULTS

Stream Protection Duration

Predeveloped Landuse Totals for POC #1
Total Pervious Area:2.633
Total Impervious Area:0

Mitigated Landuse Totals for POC #1
Total Pervious Area:1.315
Total Impervious Area:1.133

Flow Frequency Return Periods for Predeveloped. POC #1

<u>Return Period</u>	<u>Flow(cfs)</u>
2 year	0.056936
5 year	0.086485
10 year	0.102285
25 year	0.118224
50 year	0.127639
100 year	0.13535

Flow Frequency Return Periods for Mitigated. POC #1

<u>Return Period</u>	<u>Flow(cfs)</u>
2 year	0.039475
5 year	0.058922
10 year	0.075574
25 year	0.101689
50 year	0.125386
100 year	0.153234

Stream Protection Duration

POC #1

The Facility **PASSED**

The Facility **PASSED.**

Flow(cfs)	Predev	Mit	Percentage	Pass/Fail
0.0285	13428	10904	81	Pass
0.0295	12348	8054	65	Pass
0.0305	11305	6207	54	Pass
0.0315	10398	5096	49	Pass
0.0325	9604	4399	45	Pass
0.0335	8942	3869	43	Pass
0.0345	8269	3485	42	Pass
0.0355	7645	3145	41	Pass
0.0365	7093	2900	40	Pass
0.0375	6599	2704	40	Pass
0.0385	6160	2564	41	Pass
0.0395	5738	2406	41	Pass

0.0405	5336	2286	42	Pass
0.0415	4964	2161	43	Pass
0.0425	4632	2053	44	Pass
0.0435	4317	1945	45	Pass
0.0445	4030	1857	46	Pass
0.0455	3764	1768	46	Pass
0.0465	3509	1697	48	Pass
0.0475	3274	1642	50	Pass
0.0485	3076	1579	51	Pass
0.0495	2894	1528	52	Pass
0.0505	2719	1486	54	Pass
0.0515	2553	1440	56	Pass
0.0525	2404	1387	57	Pass
0.0535	2247	1347	59	Pass
0.0545	2104	1313	62	Pass
0.0555	1996	1264	63	Pass
0.0565	1870	1228	65	Pass
0.0575	1766	1184	67	Pass
0.0585	1686	1143	67	Pass
0.0595	1602	1109	69	Pass
0.0605	1535	1070	69	Pass
0.0615	1453	1040	71	Pass
0.0625	1382	1007	72	Pass
0.0635	1321	963	72	Pass
0.0645	1262	923	73	Pass
0.0655	1205	886	73	Pass
0.0665	1144	851	74	Pass
0.0675	1075	817	76	Pass
0.0685	1024	785	76	Pass
0.0695	976	746	76	Pass
0.0705	931	724	77	Pass
0.0715	892	702	78	Pass
0.0725	848	677	79	Pass
0.0735	821	657	80	Pass
0.0745	790	634	80	Pass
0.0755	764	609	79	Pass
0.0766	739	590	79	Pass
0.0776	719	569	79	Pass
0.0786	697	555	79	Pass
0.0796	667	529	79	Pass
0.0806	635	505	79	Pass
0.0816	607	482	79	Pass
0.0826	585	463	79	Pass
0.0836	558	449	80	Pass
0.0846	536	439	81	Pass
0.0856	501	417	83	Pass
0.0866	479	405	84	Pass
0.0876	466	393	84	Pass
0.0886	446	377	84	Pass
0.0896	425	362	85	Pass
0.0906	402	351	87	Pass
0.0916	384	337	87	Pass
0.0926	373	326	87	Pass
0.0936	353	315	89	Pass
0.0946	340	305	89	Pass
0.0956	326	296	90	Pass
0.0966	306	289	94	Pass
0.0976	294	281	95	Pass

0.0986	281	273	97	Pass
0.0996	272	261	95	Pass
0.1006	264	253	95	Pass
0.1016	249	244	97	Pass
0.1026	242	236	97	Pass
0.1036	229	225	98	Pass
0.1046	211	214	101	Pass
0.1056	200	206	103	Pass
0.1066	190	195	102	Pass
0.1076	177	185	104	Pass
0.1086	168	175	104	Pass
0.1096	157	161	102	Pass
0.1106	145	150	103	Pass
0.1116	137	141	102	Pass
0.1126	128	132	103	Pass
0.1136	122	123	100	Pass
0.1146	112	111	99	Pass
0.1156	103	94	91	Pass
0.1166	98	84	85	Pass
0.1176	92	80	86	Pass
0.1186	87	70	80	Pass
0.1196	84	65	77	Pass
0.1206	81	58	71	Pass
0.1216	75	55	73	Pass
0.1226	69	52	75	Pass
0.1236	63	48	76	Pass
0.1246	57	43	75	Pass
0.1256	53	42	79	Pass
0.1266	49	37	75	Pass
0.1276	46	33	71	Pass